

High Voltage, Low Quiescent, 60mA LDO Regulator

General Description

The RT9022 is designed for positive CCD bias applications with critical performance and space requirements. The RT9022 performance is optimized for battery-powered systems to deliver low noise and low quiescent current and with soft start function.

The RT9022 also works well with low-ESR ceramic capacitors, reducing the amount of board space necessary for power applications and consumes less than 1μA in shutdown mode.

The other features include ultra low dropout voltage, high output accuracy, and current limiting protection. The part is available in the SOT-23-6 and SC-70-6 packages.

Ordering Information

RT9022	□	□	
			Package Type
			E : SOT-23-6
			U6 : SC-70-6
			Lead Plating System
			P : Pb Free
			G : Green (Halogen Free and Pb Free)

Note :

Richtek products are :

- ▶ RoHS compliant and compatible with the current requirements of IPC/JEDEC J-STD-020.
- ▶ Suitable for use in SnPb or Pb-free soldering processes.

Features

- Low Quiescent Current (Typically 40μA)
- Wide Operating Voltage Ranges : 5V to 20V
- Ultra-Fast Transient Response
- Tight Load and Line Regulation
- Current Limiting Protection
- Thermal Shutdown Protection
- Adjustable Soft Start Time
- RoHS Compliant and 100% Lead (Pb)-Free

Applications

- DSC
- Camcorder

Pin Configuration

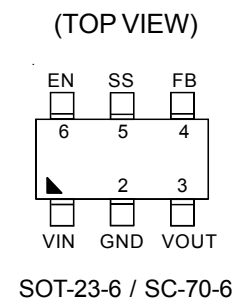

Typical Application Circuit

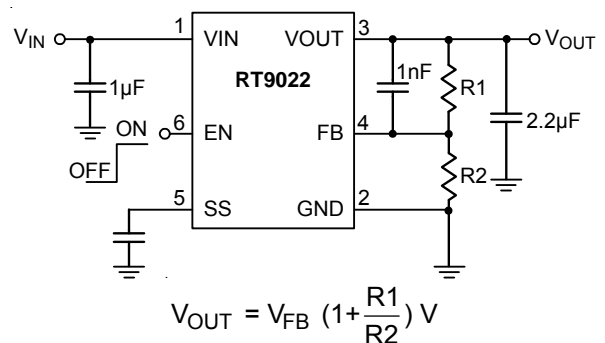

Marking Information

RT9022GE

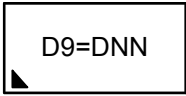

D9= : Product Code
DNN : Date Code

RT9022GU6

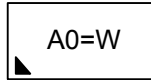

A0= : Product Code
W : Date Code

RT9022PE

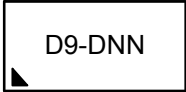

D9- : Product Code
DNN : Date Code

RT9022PU6

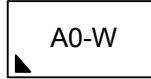

A0- : Product Code
W : Date Code

Functional Block Diagram

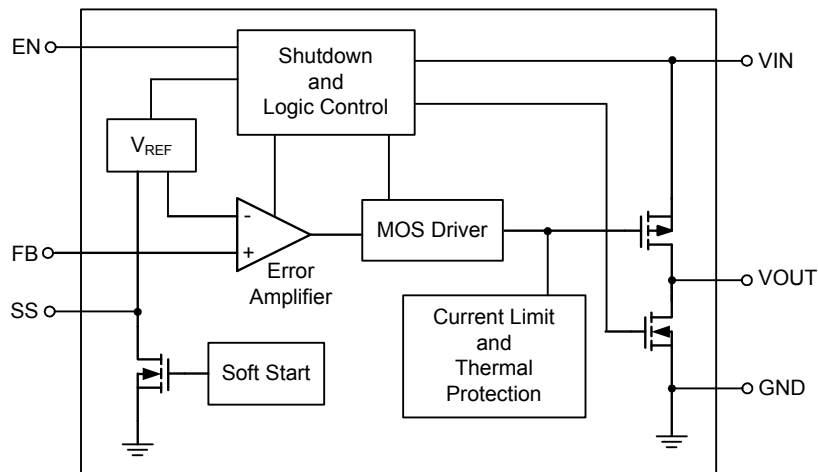

Functional Pin Description

Pin No.	Pin Name	Pin Function
1	VIN	Power Input Voltage.
2	GND	Ground.
3	VOUT	Output Voltage.
4	FB	Output Voltage Feedback.
5	SS	Soft Start and Noise Bypass.
6	EN	Chip Enable. (Active High)

Absolute Maximum Ratings (Note 1)

- Supply Input Voltage, V_{IN} ----- 21V
- Enable Voltage, V_{EN} ----- 18V
- Power Dissipation, P_D @ $T_A = 25^\circ C$
 - SOT-23-6 ----- 300mW
 - SC-70-6 ----- 225mW
- Package Thermal Resistance (Note 2)
 - SOT-23-6, θ_{JA} ----- 250°C/W
 - SC-70-6, θ_{JA} ----- 333°C/W
- Lead Temperature (Soldering, 10 sec.) ----- 260°C
- Junction Temperature ----- 150°C
- Storage Temperature Range ----- -65°C to 150°C
- ESD Susceptibility (Note 3)
 - HBM (Human Body Mode) ----- 2kV
 - MM (Machine Mode) ----- 200V

Recommended Operating Conditions (Note 4)

- Supply Input Voltage, V_{IN} ----- 5V to 20V
- Junction Temperature Range ----- -40°C to 100°C
- Ambient Temperature Range ----- -40°C to 85°C

Electrical Characteristics

($V_{IN} = V_{EN} = 15V$, $C_{IN} = 1\mu F$, $C_{OUT} = 2.2\mu F$, $T_A = 25^\circ C$, unless otherwise specified)

Parameter	Symbol	Test Conditions	Min	Typ	Max	Unit
Input Power						
Quiescent Current		$I_{OUT} = 0mA$	--	40	80	μA
Standby Current		$EN = GND$	--	--	1	μA
Reference Voltage						
Feedback Voltage		$V_{FB} = V_{OUT}$, $I_{LOAD} = 1mA$	--	1.25	--	V
Feedback Voltage Tolerance			-1	--	1	%
Feedback Input Current		$V_{FB} = 1.3V$	--	10	--	nA
Soft-Start						
Soft-Start Current			--	1.5	--	μA
Output						
Output Current Limit	I_{LIM}	$V_{IN} = 15V$, $V_{OUT} = 14V$, $R_{OUT} = 50\Omega$	70	80	--	mA
Output Reverse Leakage Current		$V_{IN} = \text{Unconnected}$, Output set to 5V	--	30	--	μA
Dropout Voltage		$I_{LOAD} = 30mA$, $V_{OUT} = 14V$	--	0.2	0.3	V
Power Supply Rejection Rate		$f = 120Hz$, $V_{IN} = V_{OUT} + 1V$, $I_{OUT} = 10mA$	--	65	--	dB
		$f = 10kHz$, $V_{IN} = V_{OUT} + 1V$, $I_{OUT} = 10mA$	--	55	--	dB
Discharge Current		$EN = \text{High to Low}$, $V_{OUT} = 14V$	--	20	--	mA

Parameter	Symbol	Test Conditions	Min	Typ	Max	Unit
EN						
EN Input Current		EN = 15V	-1	--	3	μA
EN High-Level Input Voltage	V _{EN_H}		2.4	--	--	V
EN Low-Level Input Voltage	V _{EN_L}		--	--	0.6	V
Thermal Protection						
Thermal Shutdown Temperature			--	135	--	°C
Thermal Shutdown Hysteresis			--	10	--	°C

Note 1. Stresses beyond those listed under “Absolute Maximum Ratings” may cause permanent damage to the device. These are stress ratings only, and functional operation of the device at these or any other conditions beyond those indicated in the operational sections of the specifications is not implied. Exposure to absolute maximum rating conditions may affect device reliability.

Note 2. θ_{JA} is measured at T_A = 25°C on a low effective thermal conductivity single-layer test board per JEDEC 51-3.

Note 3. Devices are ESD sensitive. Handling precaution is recommended.

Note 4. The device is not guaranteed to function outside its operating conditions.

Typical Operating Characteristics

Output Voltage vs. Temperature

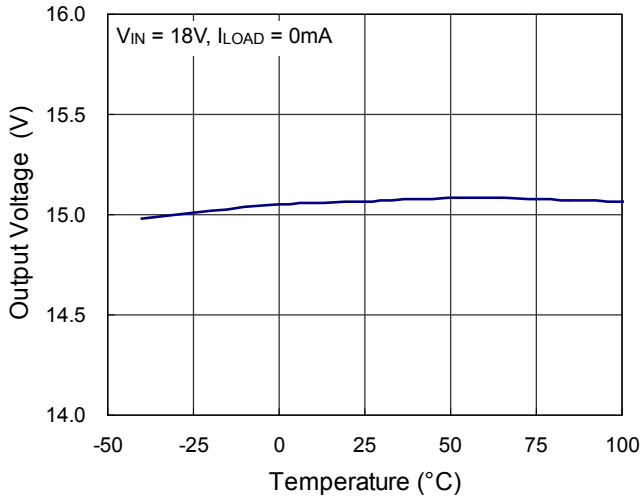

Quiescent Current vs. Temperature

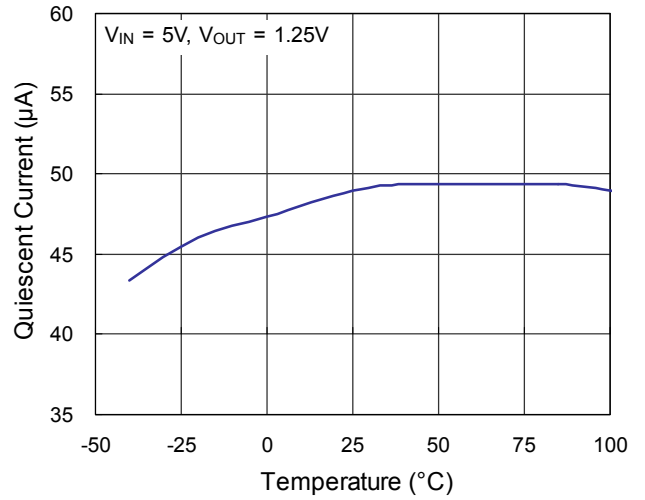

Feedback Voltage vs. Temperature

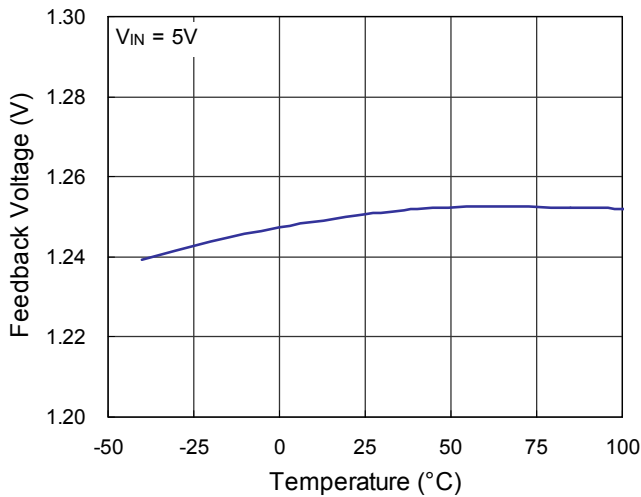

Dropout Voltage vs. Load Current

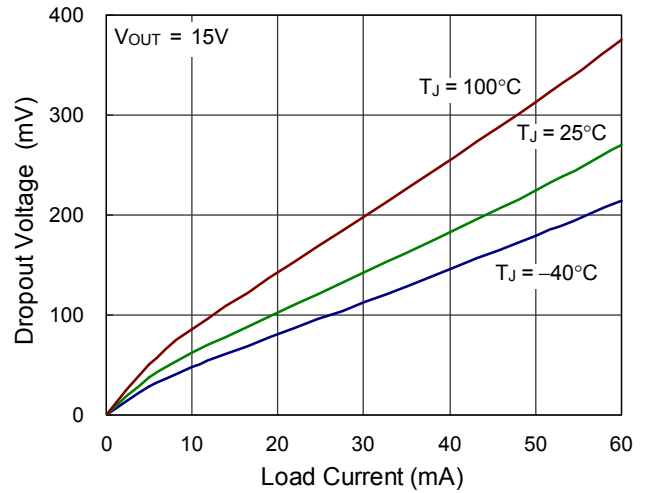

Line Transient Response

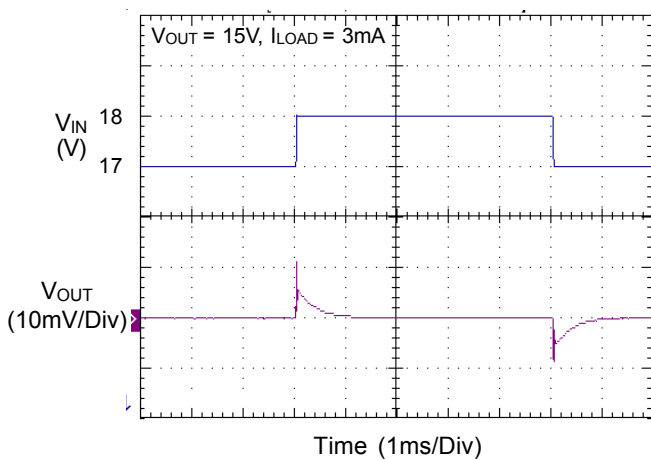

Line Transient Response

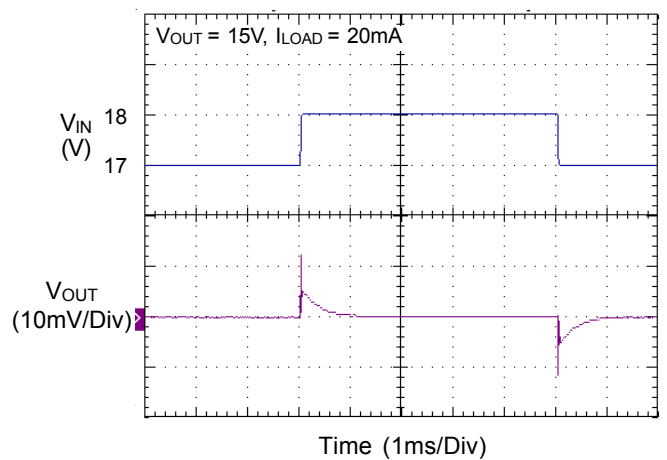

Load Transient Response

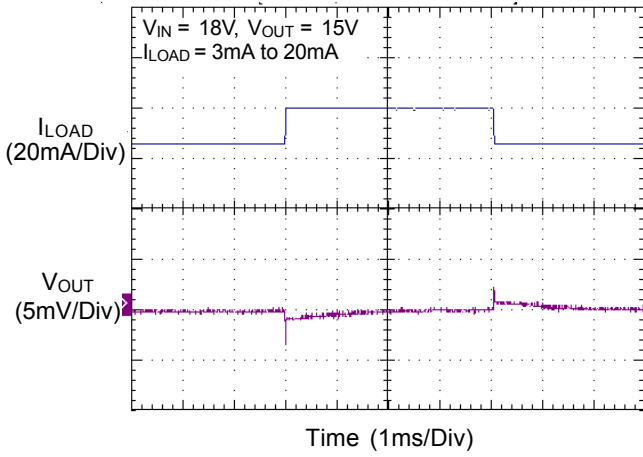

Load Transient Response

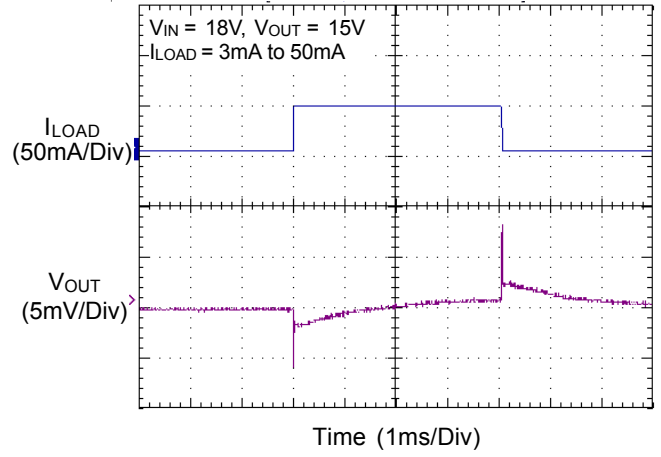

PSRR

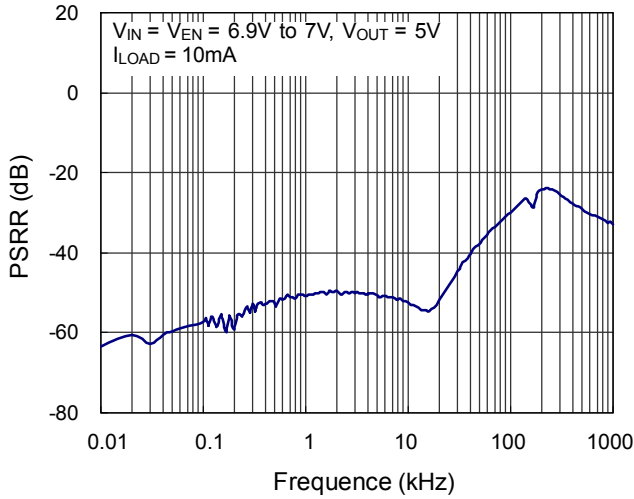

Power On/Off

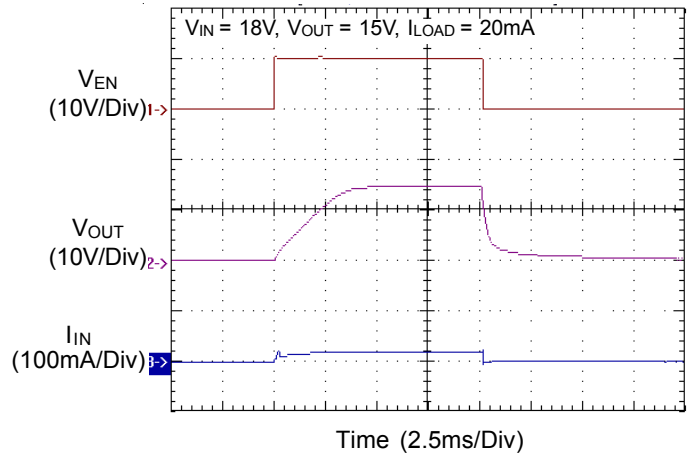

Region of Stable C_{OUT} ESR vs. Load Current

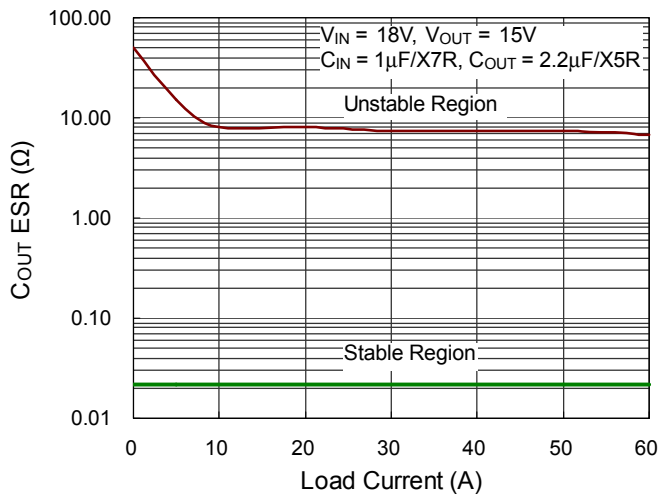

Application Information

Enable

The RT9022 goes into sleep mode when the Enable pin is in a logic low condition. During this condition, the pass transistor, error amplifier, and bandgap are turned off, reducing the supply current to 1µA. The Enable input is a CMOS logic and cannot be left floating.

Output capacitor

The RT9022 is specifically designed to use ceramic output capacitors as low as 2.2µF. Ceramic capacitors below 10µF offer significant cost and space saving, along with high frequency noise filtering. The RT9022 doesn't rely on a zero, which is generated by output capacitor ESR. So, the output capacitor ESR is not sensitive and very low ESR is allowed.

Input capacitor

A 1µF input capacitor or greater located as close as possible to the IC is recommended. Larger input capacitor value with lower ESR provides better power supply noise rejection and line transient response. Larger load current requires larger capacitor value.

PSRR

The power supply rejection ratio (PSRR) is defined as the gain from the input to output divided by the gain from the supply to the output. The PSRR is found to be

$$PSRR = 20 \times \log \left(\frac{\Delta \text{Gain Error}}{\Delta \text{Supply}} \right)$$

Note that when heavy load is measured, Δsupply will cause Δtemperature. And Δtemperature will cause Δoutput voltage. So the temperature effect must be taken into consideration.

Current Limit

The RT9022 contains an independent current limiter, which monitors and controls the pass transistor's gate voltage to limit the output current to 80mA typically. It protects the part even directly short the output to GND.

Thermal Consideration

Thermal protection limits power dissipation in the RT9022. When the operating junction temperature exceeds 135°C, the OTP circuit starts the thermal shutdown function and turns the pass element off. The pass element turns on again after the junction temperature cools by 10°C.

For continuous operation, do not exceed absolute maximum operation junction temperature 125°C. The power dissipation definition in device is :

$$P_D = (V_{IN} - V_{OUT}) \times I_{OUT} + V_{IN} \times I_Q$$

The maximum power dissipation depends on the thermal resistance of IC package, PCB layout, the rate of surroundings airflow and temperature difference between junction to ambient. The maximum power dissipation can be calculated by following formula :

$$P_{D(MAX)} = (T_{J(MAX)} - T_A) / \theta_{JA}$$

Where $T_{J(MAX)}$ is the maximum operation junction temperature 100°C, T_A is the ambient temperature and the θ_{JA} is the junction to ambient thermal resistance.

For recommended operating conditions specification of the RT9022, where $T_{J(MAX)}$ is the maximum junction temperature of the die (100°C) and T_A is the maximum ambient temperature. The junction to ambient thermal resistance (θ_{JA} is layout dependent) for SOT-23-6 package is 250°C/W, and SC-70-6 package is 333°C/W on standard JEDEC 51-3 thermal test board. The maximum power dissipation at $T_A = 25^\circ\text{C}$ can be calculated by following formula :

$$P_{D(MAX)} = (100^\circ\text{C} - 25^\circ\text{C}) / 250^\circ\text{C/W} = 300\text{mW for SOT-23-6 package}$$

$$P_{D(MAX)} = (100^\circ\text{C} - 25^\circ\text{C}) / 333^\circ\text{C/W} = 225\text{mW for SC-70-6 package}$$

The maximum power dissipation depends on operating ambient temperature for fixed $T_{J(MAX)}$ and thermal resistance θ_{JA} . The Figure 1 of de-rating curves allows the designer to see the effect of rising ambient temperature on the maximum power allowed.

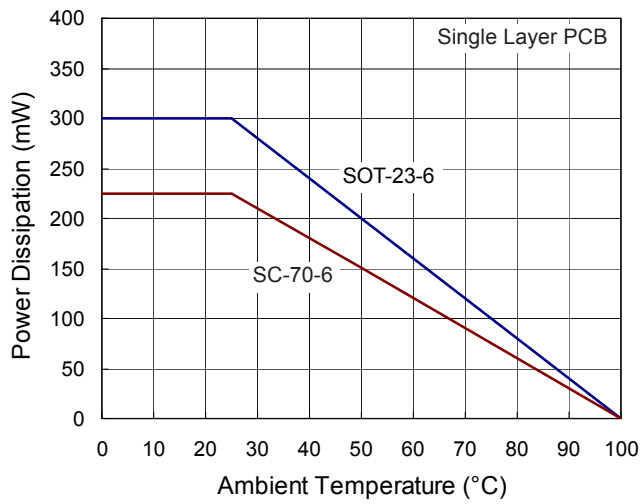
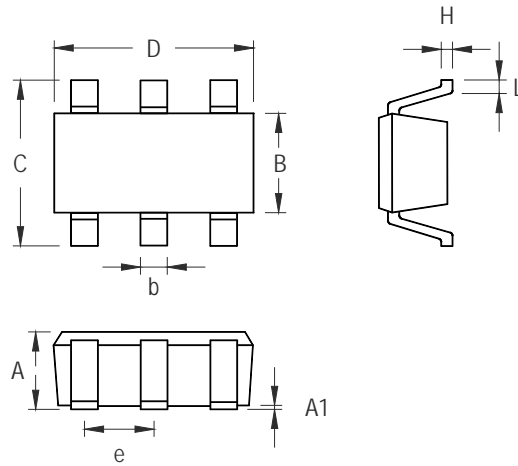

Figure 1. De-rating Curves

Outline Dimension



Symbol	Dimensions In Millimeters		Dimensions In Inches	
	Min	Max	Min	Max
A	0.889	1.295	0.031	0.051
A1	0.000	0.152	0.000	0.006
B	1.397	1.803	0.055	0.071
b	0.250	0.560	0.010	0.022
C	2.591	2.997	0.102	0.118
D	2.692	3.099	0.106	0.122
e	0.838	1.041	0.033	0.041
H	0.080	0.254	0.003	0.010
L	0.300	0.610	0.012	0.024

SOT-23-6 Surface Mount Package

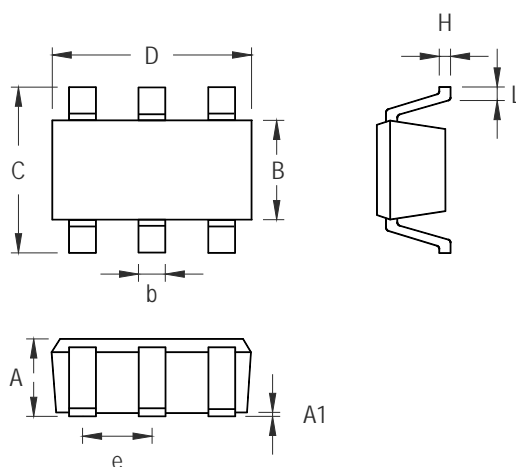

Symbol	Dimensions In Millimeters		Dimensions In Inches	
	Min	Max	Min	Max
A	0.800	1.100	0.031	0.044
A1	0.000	0.100	0.000	0.004
B	1.150	1.350	0.045	0.054
b	0.150	0.400	0.006	0.016
C	1.800	2.450	0.071	0.096
D	1.800	2.250	0.071	0.089
e	0.650		0.026	
H	0.080	0.260	0.003	0.010
L	0.210	0.460	0.008	0.018

SC-70-6 Surface Mount Package

Footprint Information

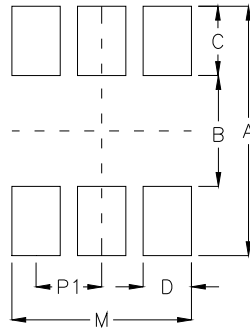

Package	Number of Pin	Footprint Dimension (mm)						Tolerance
		P1	A	B	C	D	M	
TSOT-26/TSOT-26(FC)/SOT-26/SOT-26(COL)	6	0.95	3.60	1.60	1.00	0.70	2.60	±0.10

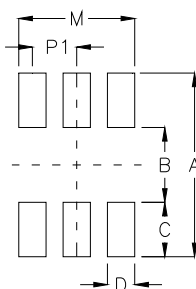

Package	Number of Pin	Footprint Dimension (mm)						Tolerance
		P1	A	B	C	D	M	
SC-70-6	6	0.65	2.70	1.10	0.80	0.40	1.70	±0.10

Richtek Technology Corporation

5F, No. 20, Taiyuen Street, Chupei City

Hsinchu, Taiwan, R.O.C.

Tel: (8863)5526789

Richtek products are sold by description only. Richtek reserves the right to change the circuitry and/or specifications without notice at any time. Customers should obtain the latest relevant information and data sheets before placing orders and should verify that such information is current and complete. Richtek cannot assume responsibility for use of any circuitry other than circuitry entirely embodied in a Richtek product. Information furnished by Richtek is believed to be accurate and reliable. However, no responsibility is assumed by Richtek or its subsidiaries for its use; nor for any infringements of patents or other rights of third parties which may result from its use. No license is granted by implication or otherwise under any patent or patent rights of Richtek or its subsidiaries.

X-ON Electronics

Largest Supplier of Electrical and Electronic Components

Click to view similar products for [LDO Voltage Regulators](#) category:

Click to view products by [Richtek](#) manufacturer:

Other Similar products are found below :

[AP7363-SP-13](#) [NCV8664CST33T3G](#) [L79M05TL-E](#) [AP7362-HA-7](#) [PT7M8202B12TA5EX](#) [TCR3DF185,LM\(CT](#) [TLF4949EJ](#)
[NCP4687DH15T1G](#) [NCV8703MX30TCG](#) [LP2951CN](#) [NCV4269CPD50R2G](#) [AP7315-25W5-7](#) [NCV47411PAAJR2G](#) [AP2111H-1.2TRG1](#)
[ZLDO1117QK50TC](#) [AZ1117ID-ADJTRG1](#) [NCV4263-2CPD50R2G](#) [NCP706ABMX300TAG](#) [NCP114BMX075TCG](#) [MC33269T-3.5G](#)
[TLE4471GXT](#) [AP7315-33SA-7](#) [NCV4266-2CST33T3G](#) [NCP715SQ15T2G](#) [NCV8623MN-50R2G](#) [NCV563SQ18T1G](#) [NCV8664CDT33RKG](#)
[NCV4299CD250R2G](#) [NCP715MX30TBG](#) [NCV8702MX25TCG](#) [TLE7270-2E](#) [NCV562SQ25T1G](#) [AP2213D-3.3TRG1](#) [AP2202K-2.6TRE1](#)
[NCV8170BMX300TCG](#) [NCV8152MX300180TCG](#) [NCP700CMT45TBG](#) [AP7315-33W5-7](#) [NCP154MX180300TAG](#) [AP2113AMTR-G1](#)
[NJW4104U2-33A-TE1](#) [MP2013AGG-5-P](#) [NCV8775CDT50RKG](#) [NJM2878F3-45-TE1](#) [S-19214B00A-V5T2U7](#) [S-19214B50A-V5T2U7](#) [S-](#)
[19213B50A-V5T2U7](#) [S-19214BC0A-E8T1U7*1](#) [S-19213B00A-V5T2U7](#) [S-19213B33A-V5T2U7](#)