

3A High Performance Step-Up DC/DC Converter

General Description

The RT9297 includes a high performance step-up DC/DC converter that provides a regulated supply voltage for active-matrix thin-film transistor (TFT) liquid-crystal displays (LCDs).

The Boost Converter incorporates current mode, fixed-frequency, pulse-width modulation (PWM) circuitry with a built-in N-Channel power MOSFET to achieve high efficiency and fast transient response.

The RT9297 is available in a WDFN -10L 3x3 package.

Ordering Information

RT9297 □ □

- Package Type
QW : WDFN-10L 3x3 (W-Type)
- Lead Plating System
G : Green (Halogen Free and Pb Free)

Note :

Richtek products are :

- ▶ RoHS compliant and compatible with the current requirements of IPC/JEDEC J-STD-020.
- ▶ Suitable for use in SnPb or Pb-free soldering processes.

Marking Information

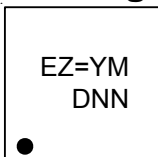

EZ= : Product Code
YMDNN : Date Code

Features

- High Efficiency Up to 90%
- Adjustable Output Voltage : V_{DD} to 24V
- Wide Input Supply Voltage : 2.6V to 5.5V
- Input Under Voltage Lockout
- Pin-Programmable Switching Frequency 640kHz/1.2MHz
- Programmable Soft-Start
- Small 10-Lead WDFN Package
- RoHS Compliant and Halogen Free

Applications

- Notebook Computer Displays
- LCD Monitor Panels
- LCD TV Panels

Pin Configurations

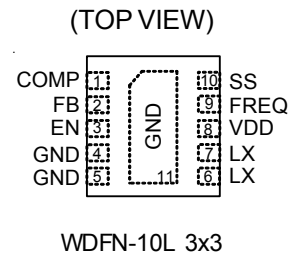

Typical Application Circuit

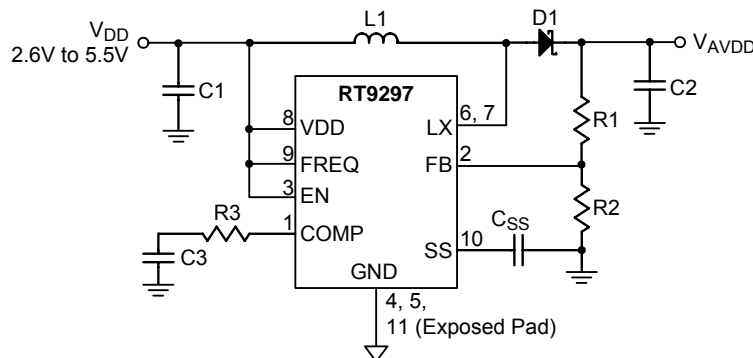

Function Block Diagram

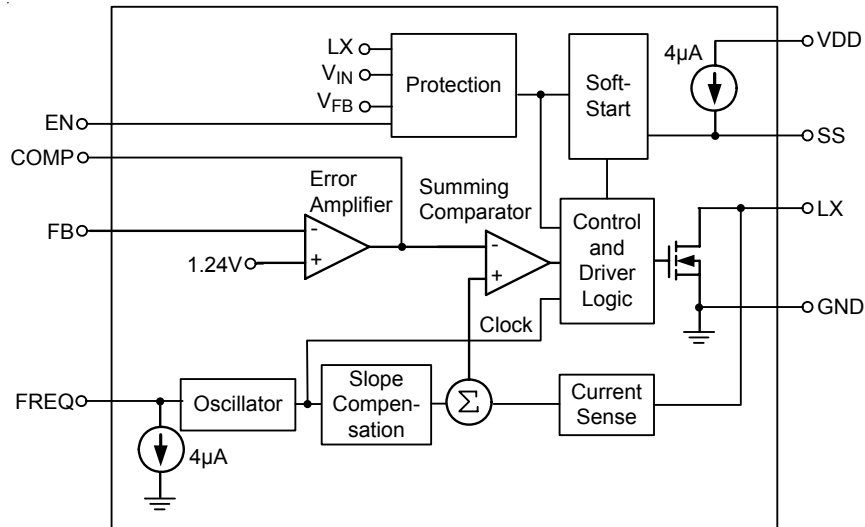

Functional Pin Description

| Pin No. | Pin Name | Pin Function |
|--------------------------|----------|--|
| 1 | COMP | Compensation Pin for Error Amplifier. Connect a series RC from COMP to ground. |
| 2 | FB | Feedback. The feedback regulation voltage is 1.24V nominal. Connect an external resistive voltage-divider between the step-up regulator's output (V_{AVDD}) and GND, with the center tap connected to FB. Place the divider close to the IC and minimize the trace area to reduce noise coupling. |
| 3 | EN | Enable Control Input. Drive EN low to turn off the Boost Converter. |
| 4, 5 11 (Exposed Pad) | GND | Ground. The exposed pad must be soldered to a large PCB and connected to GND for maximum power dissipation. |
| 6, 7 | LX | Switch. LX is the drain of the internal MOSFET. Connect the inductor/rectifier diode junction to LX and minimize the trace area for lower EMI. |
| 8 | VDD | Supply Pin. Bypass V_{DD} with a minimum 1µF ceramic capacitor directly to GND. |
| 9 | FREQ | Frequency-Select Input. When FREQ is low, the oscillator frequency will be set to 640kHz. When FREQ is high, the frequency will be set to 1.2MHz. This input has a 6µA pull-down current. |
| 10 | SS | Soft-Start Control. Connect a soft-start capacitor (C_{SS}) to this pin. A 4µA constant current charges the soft-start capacitor. When EN connected to GND, the soft-start capacitor is discharged. When EN connected to V_{DD} high, the soft-start capacitor is charged to V_{DD} . Leave floating for not using soft-start. |

Absolute Maximum Ratings (Note 1)

- LX to GND ----- -0.3V to 26V
- Other Pins to GND ----- -0.3V to 6V
- Power Dissipation, P_D @ $T_A = 25^\circ\text{C}$
 WDFN-10L 3x3 ----- 1.667W
- Package Thermal Resistance (Note 2)
 WDFN-10L 3x3, θ_{JA} ----- 60°C/W
 WDFN-10L 3x3, θ_{JC} ----- 8.2°C/W
- Lead Temperature (Soldering, 10 sec.) ----- 260°C
- Junction Temperature ----- 150°C
- Storage Temperature Range ----- -65°C to 150°C
- ESD Susceptibility (Note 3)
 HBM (Human Body Model) ----- 2kV
 MM (Machine Model) ----- 200V

Recommended Operating Conditions (Note 4)

- Supply Input Voltage, V_{DD} ----- 2.6V to 5.5V
- Junction Temperature Range ----- -40°C to 125°C
- Ambient Temperature Range ----- -40°C to 85°C

Electrical Characteristics

($V_{DD} = 3.3\text{V}$, $T_A = 25^\circ\text{C}$, unless otherwise specified)

| Parameter | Symbol | Test Conditions | Min | Typ | Max | Unit |
|---------------------------------|------------|---|----------|------|------|---------------|
| Supply Current | | | | | | |
| Input Voltage Range | V_{DD} | $V_{AVDD} < 18\text{V}$ | 2.6 | -- | 5.5 | V |
| | | $18\text{V} < V_{AVDD} < 24\text{V}$ | 4 | -- | 5.5 | |
| Output Voltage Range | V_{AVDD} | | V_{DD} | -- | 24 | V |
| Under-Voltage Lockout Threshold | V_{UVLO} | V_{DD} Rising | -- | 2.4 | -- | V |
| | | Hysteresis | -- | 50 | -- | mV |
| Quiescent Current | I_Q | $V_{FB} = 1.3\text{V}$, LX Not Switching | -- | 0.5 | -- | mA |
| | | $V_{FB} = 1\text{V}$, LX Switching | -- | 4 | -- | |
| Shutdown Current | I_{SHDN} | EN = GND | -- | 0.1 | 10 | μA |
| Oscillator | | | | | | |
| Oscillator Frequency | f_{OSC} | FREQ = GND | 500 | 640 | 750 | kHz |
| | | FREQ = V_{IN} | 1000 | 1240 | 1500 | |
| Maximum Duty Cycle | | | -- | 90 | -- | % |
| Error Amplifier | | | | | | |
| Feedback Regulation Voltage | V_{FB} | | 1.22 | 1.24 | 1.26 | V |
| Feedback Input Bias Current | I_{FB} | | -- | 125 | 250 | nA |

| Parameter | Symbol | Test Conditions | Min | Typ | Max | Unit |
|-------------------------------|---------------------|--|-----------------------|-----------------------|-----------------------|------------|
| Feedback Line Regulation | | | -- | 0.05 | 0.2 | %/V |
| Transconductance | gm | $\Delta I = \pm 2.5\mu A$ at COMP = 1V | -- | 135 | -- | $\mu A/V$ |
| Voltage Gain | Av | FB to COMP | -- | 700 | -- | V/V |
| N- MOSFET | | | | | | |
| Current Limit | I _{LIM} | | 3 | 3.8 | 5 | A |
| On-Resistance | R _{DS(ON)} | | -- | 125 | 250 | m Ω |
| Leakage Current | I _{LEAK} | V _{LX} = 24V | -- | 30 | 45 | μA |
| Current-Sense Transresistance | R _{CS} | | -- | 0.25 | -- | V/A |
| Soft-Start | | | | | | |
| Charge Current | I _{SS} | | -- | 4 | -- | μA |
| Control Inputs | | | | | | |
| EN, FREQ Input Low Voltage | V _{IL} | | -- | -- | 0.3 x V _{DD} | V |
| EN, FREQ Input High Voltage | V _{IH} | | 0.7 x V _{DD} | -- | -- | V |
| EN, FREQ Input Hysteresis | | | -- | 0.1 x V _{DD} | -- | V |
| FREQ Pull-down Current | | | -- | 6 | -- | μA |
| EN Input Current | I _{EN} | EN = GND | -- | 0.001 | 1 | μA |

Note 1. Stresses beyond those listed “Absolute Maximum Ratings” may cause permanent damage to the device. These are stress ratings only, and functional operation of the device at these or any other conditions beyond those indicated in the operational sections of the specifications is not implied. Exposure to absolute maximum rating conditions may affect device reliability.

Note 2. θ_{JA} is measured at T_A = 25°C on a high effective thermal conductivity four-layer test board per JEDEC 51-7. θ_{JC} is measured at the exposed pad of the package.

Note 3. Devices are ESD sensitive. Handling precaution is recommended.

Note 4. The device is not guaranteed to function outside its operating conditions.

Typical Operating Characteristics

Efficiency vs. Load Current

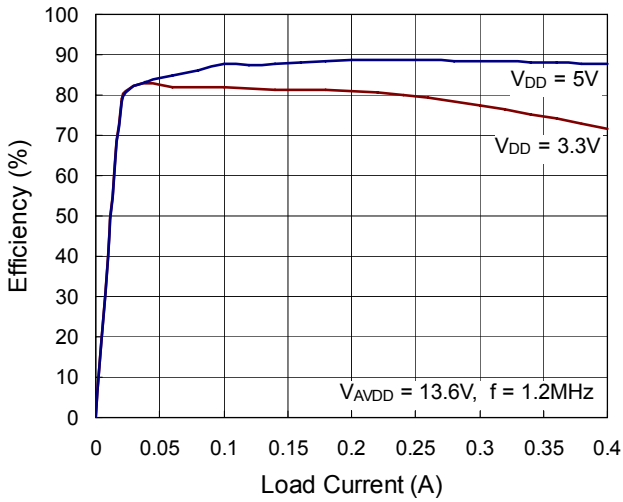

Efficiency vs. Load Current

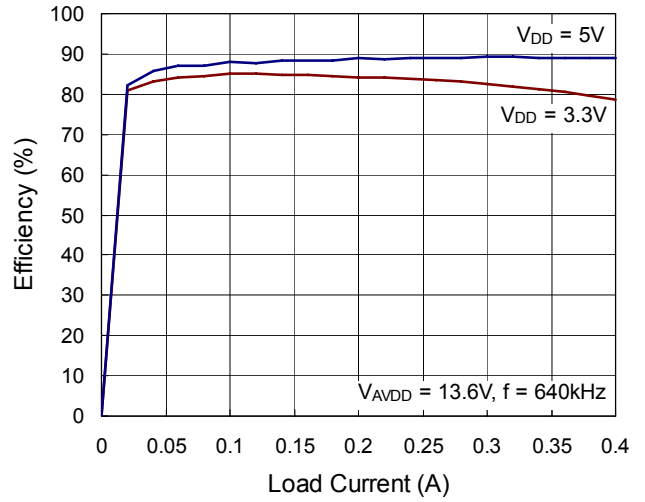

Output Voltage vs. Load Current

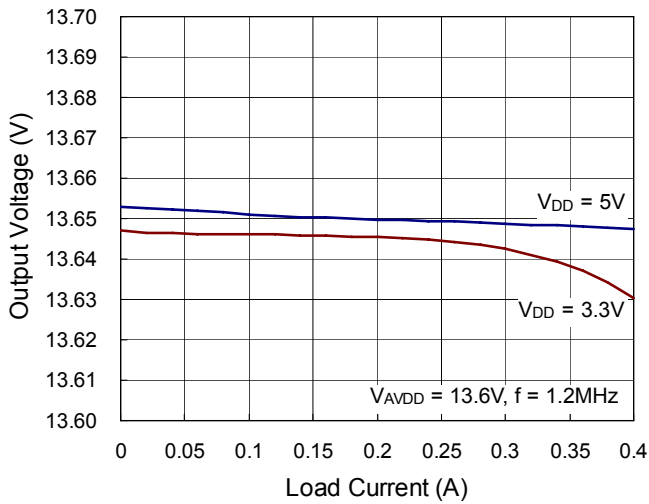

Output Voltage vs. Load Current

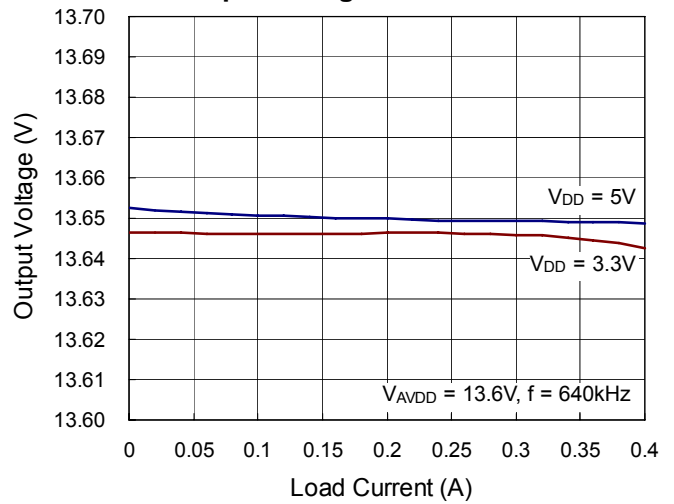

Output Voltage vs. Input Voltage

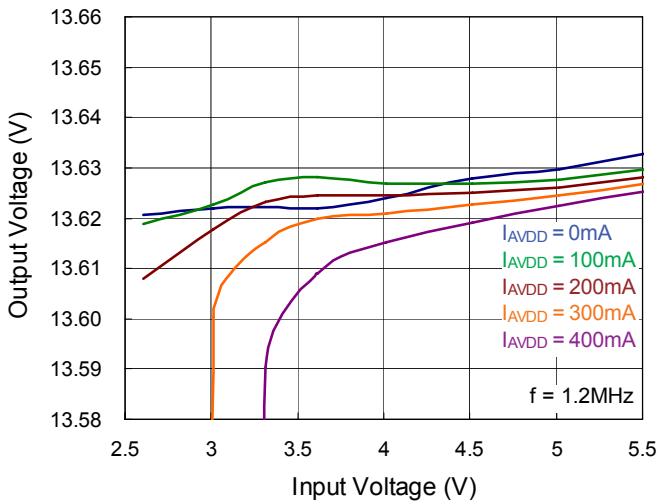

Output Voltage vs. Input Voltage

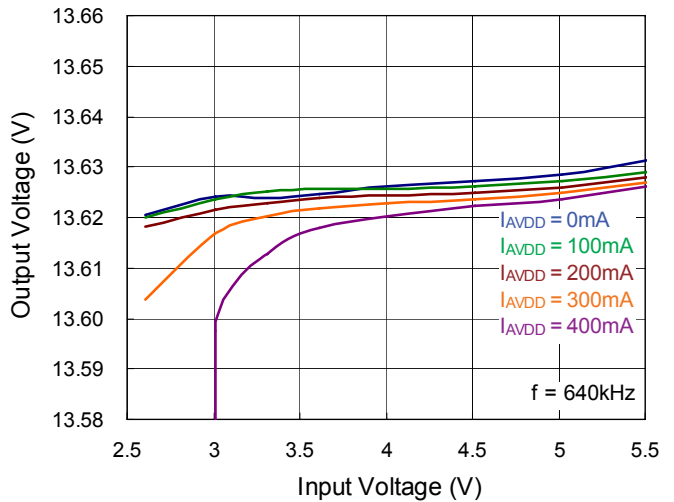

Switching Frequency vs. Temperature

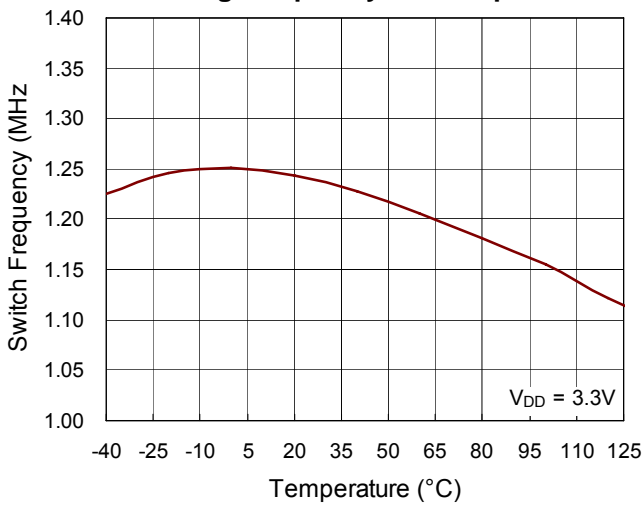

Reference Voltage vs. Temperature

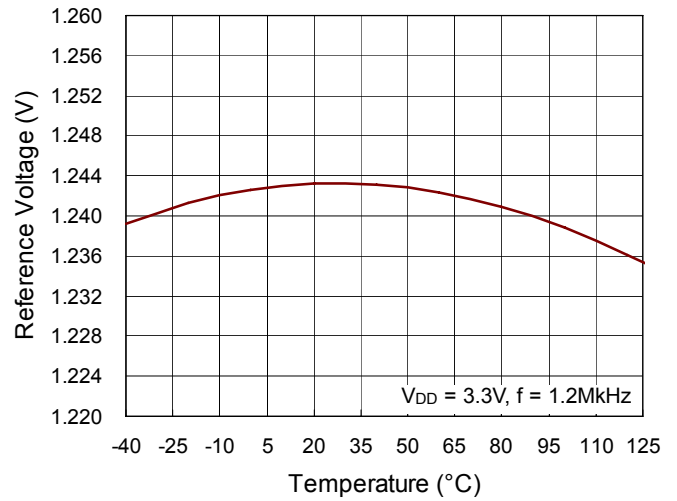

Start Up

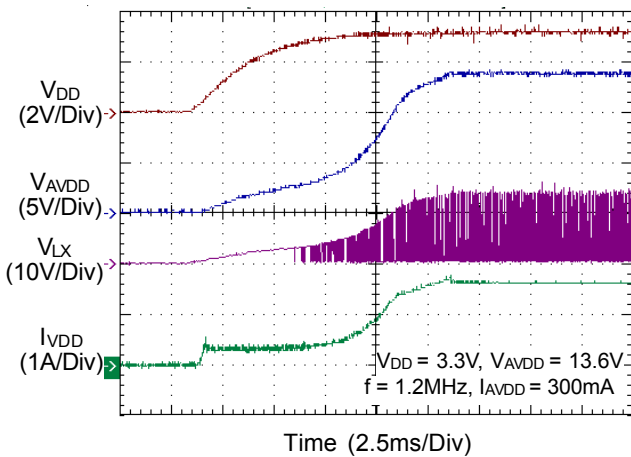

Start Up

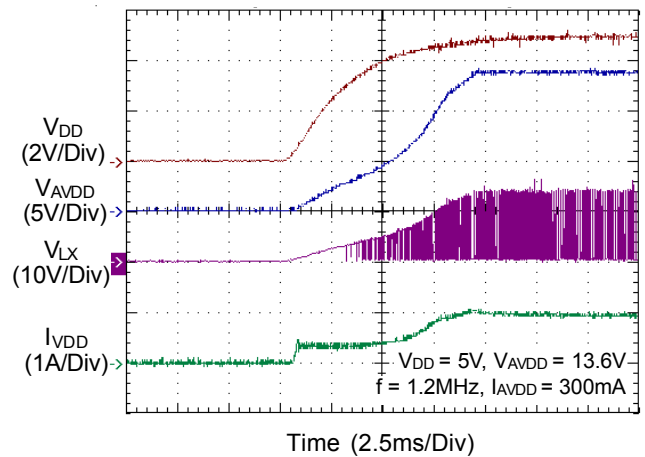

Load Transient Response

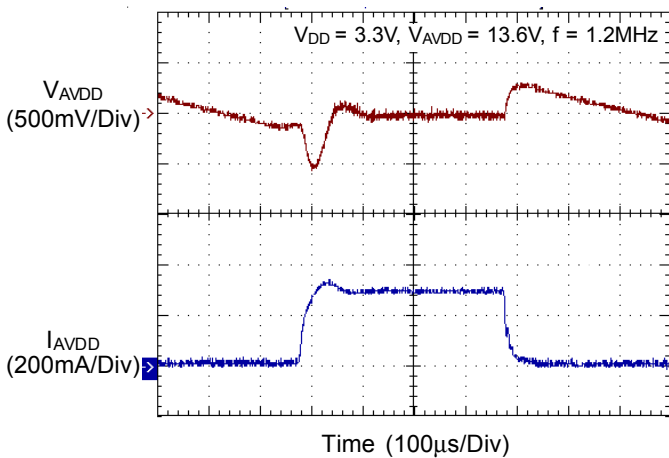

Load Transient Response

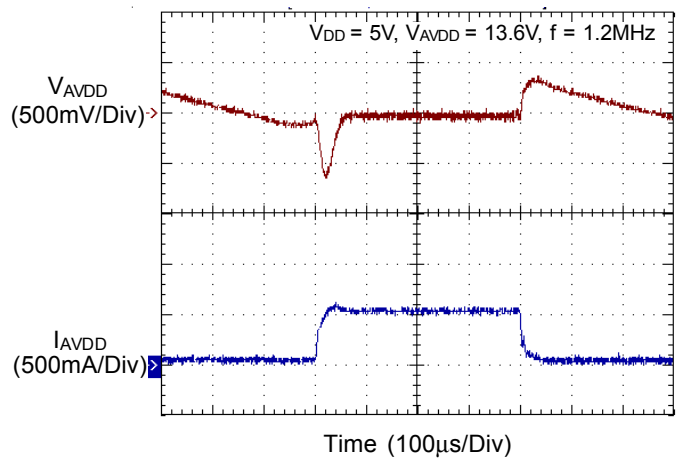

Application Information

The RT9297 contains a high performance boost regulator to generate voltage for the panel source driver ICs. The following content contains the detailed description and the information of component selection.

Boost Regulator

The boost regulator is a high efficiency current-mode PWM architecture with 640K / 1.2MHz operation frequency. It performs fast transient responses to generate source driver supplies for TFT LCD display. The high operation frequency allows smaller components used to minimize the thickness of the LCD panel. The output voltage setting can be achieved by setting the resistive voltage-divider sensing at FB pin. The error amplifier varies the COMP voltage by sensing the FB pin to regulate the output voltage. For better stability, the slope compensation signal summed with the current-sense signal will be compared with the COMP voltage to determine the current trip point and duty cycle.

Soft-Start

The RT9297 provides soft-start function to minimize the inrush current. When power on, an internal constant current charges an external capacitor. The rising voltage rate on the COMP pin is limited during the charging period and the inductor peak current will also be limited at the same time. When power off, the external capacitor will be discharged for next soft start time.

The soft-start function is implemented by the external capacitor with a 4μA constant current charging to the soft-start capacitor. Therefore, the capacitor should be large enough for output voltage regulation. Typical value for soft-start capacitor range is 33nF. The available soft-start capacitor range is from 10nF to 100nF.

Output Voltage Setting

The regulated output voltage is shown as following equation :

$$V_{AVDD} = 1.24V \times \left(1 + \frac{R_1}{R_2}\right)$$

The recommended value for R2 should be up to 10kΩ without some sacrificing. To place the resistor divider as close as possible to the chip can reduce noise sensitivity.

Loop Compensation

The voltage feedback loop can be compensated with an external compensation network consisted of R_{COMP} and C_{COMP}. Choose R_{COMP} to set high frequency integrator gain for fast transient response and C_{COMP} to set the integrator zero to maintain loop stability. For typical application V_{DD} = 3.3V , V_{AVDD} = 13.6V , C4 = 4.7μF x 3 , L = 3.6μH, the recommended value for compensation is as below : R_{COMP} = 56kΩ, C_{COMP} = 330pF.

Over Current Protection

The RT9297 boost converter has over-current protection to limit peak inductor current. It prevents large current from damaging the inductor and diode. During the ON-time, once the inductor current exceeds the current limit, the internal LX switch turns off immediately and shortens the duty cycle. Therefore, the output voltage drops if the over-current condition occurs. The current limit there should is also affected by the input voltage, duty cycle and inductor value.

Over Temperature Protection

The RT9297 boost converter has thermal protection function to prevent the chip from overheating. When the junction temperature exceeds 155°C, it will shut down the device. Once the device cools down by approximately 30°C, it will start to operate normally. For continuous operation, do not operate over the maximum junction temperature rating 125°C.

Inductor Selection

The inductance depends on the maximum input current. The inductor current ripple is 20% to 40% of maximum input current that is a general rule. Assume, choose 40% as the criterion then

$$I_{VDD(MAX)} = \frac{V_{AVDD} \times I_{AVDD(MAX)}}{\eta \times V_{DD}}$$

$$I_{RIPPLE} = 0.4 \times I_{VDD(MAX)}$$

Where η is the efficiency, I_{IN(MAX)} is the maximum input current, I_{RIPPLE} is the inductor current ripple. Beside, the input peak current is maximum input current plus half of inductor current ripple.

$$I_{PEAK} = 1.2 \times I_{VDD(MAX)}$$

Note that the saturated current of inductor must be greater than I_{PEAK} . The inductance can be eventually determined as follow equation :

$$L = \frac{\eta \times (V_{DD})^2 \times (V_{AVDD} - V_{DD})}{0.4 \times (V_{AVDD})^2 \times I_{AVDD(MAX)} \times f_{OSC}}$$

Where f_{OSC} is the switching frequency. To consider the system performance, a shielded inductor is preferred to avoid EMI issue.

Diode Selection

Schottky diode is a good choice for an asynchronous Boost converter due to the small forward voltage. However, power dissipation, reverse voltage rating and pulsating peak current are the important parameters for Schottky diode selection. It is recommended to choose a suitable diode whose reverse voltage rating is greater than the maximum output voltage.

Capacitor Selection

Output ripple voltage is an important index for estimating the performance. This portion consists of two parts, one is the product of input current and ESR of output capacitor, another part is formed by charging and discharging process of output capacitor. Refer to Figure 1, evaluate ΔV_{OUT1} by ideal energy equalization. According to the definition of Q, the Q value can be calculated as following equation :

$$Q = \frac{1}{2} \times \left[\left(I_{IN} + \frac{1}{2} \Delta I_L - I_{OUT} \right) + \left(I_{IN} - \frac{1}{2} \Delta I_L - I_{OUT} \right) \right] \times \frac{V_{IN}}{V_{OUT}} \times \frac{1}{f_{SW}} = C_{OUT} \times \Delta V_{OUT1}$$

where f_{SW} is the switching frequency, and ΔI_L is the inductor ripple current. Move C_{OUT} to the left side to estimate the value of ΔV_{OUT1} as the following equation :

$$\Delta V_{OUT1} = \frac{D \times I_{OUT}}{\eta \times C_{OUT} \times f_{SW}}$$

Finally, by taking ESR into consideration, the overall output ripple voltage can be determined as the following equation :

$$\Delta V_{OUT} = I_{IN} \times ESR + \frac{D \times I_{OUT}}{\eta \times C_{OUT} \times f_{SW}}$$

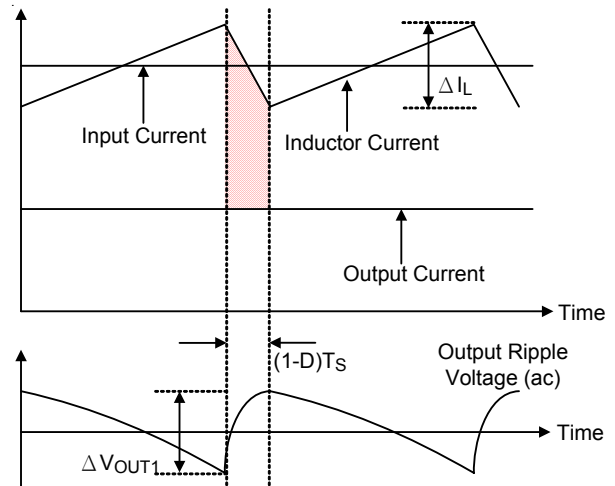

Figure 1. The Output Ripple Voltage without the Contribution of ESR

Input Capacitor Selection

Low ESR ceramic capacitors are recommended for input capacitor applications. Low ESR will effectively reduce the input voltage ripple caused by switching operation. A 10μF is sufficient for most applications. Nevertheless, this value can be decreased for lower output current requirement. Another consideration is the voltage rating of the input capacitor must be greater than the maximum input voltage.

Thermal Considerations

For continuous operation, do not exceed absolute maximum operation junction temperature. The maximum power dissipation depends on the thermal resistance of IC package, PCB layout, the rate of surroundings airflow and temperature difference between junction to ambient. The maximum power dissipation can be calculated by following formula :

$$P_{D(MAX)} = (T_{J(MAX)} - T_A) / \theta_{JA}$$

Where $T_{J(MAX)}$ is the maximum operation junction temperature 125°C, T_A is the ambient temperature and the θ_{JA} is the junction to ambient thermal resistance.

For recommended operating conditions specification, where $T_{J(MAX)}$ is the maximum junction temperature of the die (125°C) and T_A is the maximum ambient temperature. The junction to ambient thermal resistance θ_{JA} is layout

dependent. For WDFN-10L 3x3 packages, the thermal resistance θ_{JA} is 60°C/W on the standard JEDEC 51-7 four layers thermal test board. The maximum power dissipation at $T_A = 25^\circ\text{C}$ can be calculated by following formula :

$$P_{D(\text{MAX})} = (125^\circ\text{C} - 25^\circ\text{C}) / (60^\circ\text{C}/\text{W}) = 1.667\text{W}$$

for WDFN-10L 3x3 package

The maximum power dissipation depends on operating ambient temperature for fixed $T_{J(\text{MAX})}$ and thermal resistance θ_{JA} . The Figure 2 of derating curves allows the designer to see the effect of rising ambient temperature on the maximum power allowed.

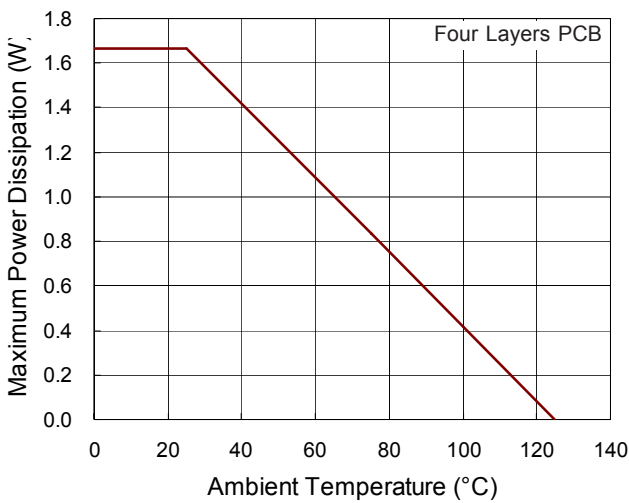

Figure 2. Derating Curve of Maximum Power Dissipation

Layout Considerations

For high frequency switching power supplies, the PCB layout is important to get good regulation, high efficiency and stability. The following descriptions are the guidelines for better PCB layout.

- ▶ For good regulation, place the power components as close as possible. The traces should be wide and short enough especially for the high-current output loop.
- ▶ The feedback voltage-divider resistors must be near the feedback pin. The divider center trace must be shorter and the trace must be kept away from any switching nodes.
- ▶ The compensation circuit should be kept away from the power loops and be shielded with a ground trace to prevent any noise coupling.
- ▶ Minimize the size of the LX node and keep it wide and shorter. Keep the LX node away from the FB.
- ▶ The exposed pad of the chip should be connected to a strong ground plane for maximum thermal consideration.

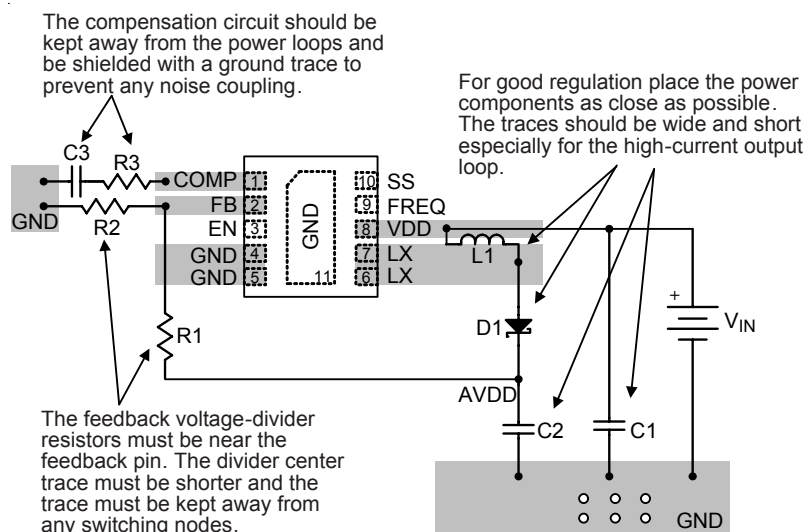
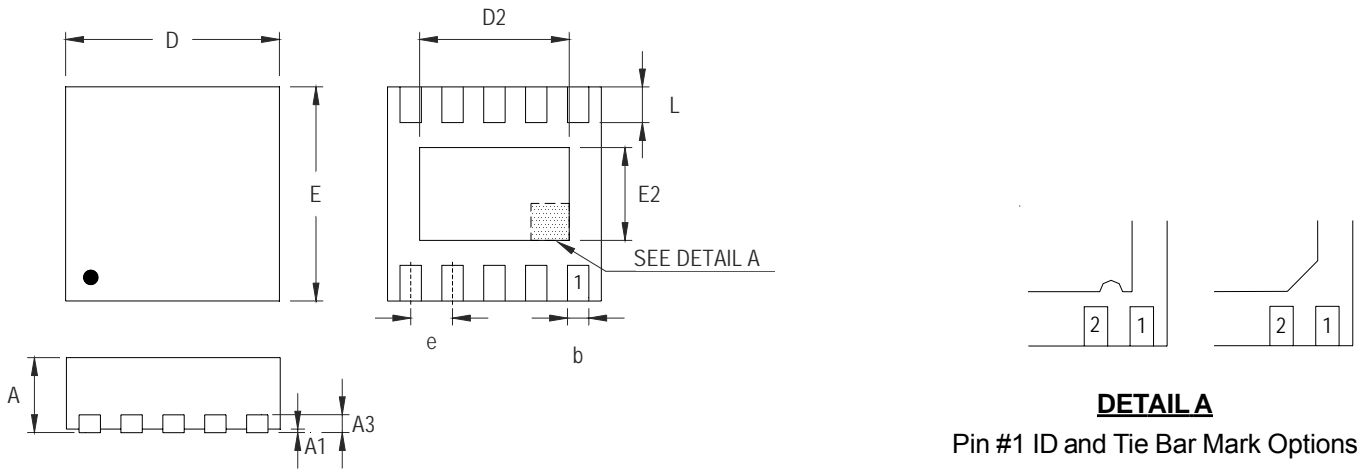

Figure 3. PCB Layout Guide

Outline Dimension



DETAIL A

Pin #1 ID and Tie Bar Mark Options

Note : The configuration of the Pin #1 identifier is optional, but must be located within the zone indicated.

| Symbol | Dimensions In Millimeters | | Dimensions In Inches | |
|--------|---------------------------|-------|----------------------|-------|
| | Min | Max | Min | Max |
| A | 0.700 | 0.800 | 0.028 | 0.031 |
| A1 | 0.000 | 0.050 | 0.000 | 0.002 |
| A3 | 0.175 | 0.250 | 0.007 | 0.010 |
| b | 0.180 | 0.300 | 0.007 | 0.012 |
| D | 2.950 | 3.050 | 0.116 | 0.120 |
| D2 | 2.300 | 2.650 | 0.091 | 0.104 |
| E | 2.950 | 3.050 | 0.116 | 0.120 |
| E2 | 1.500 | 1.750 | 0.059 | 0.069 |
| e | 0.500 | | 0.020 | |
| L | 0.350 | 0.450 | 0.014 | 0.018 |

W-Type 10L DFN 3x3 Package

Richtek Technology Corporation

5F, No. 20, Taiyuen Street, Chupei City
 Hsinchu, Taiwan, R.O.C.
 Tel: (8863)5526789

Richtek products are sold by description only. Richtek reserves the right to change the circuitry and/or specifications without notice at any time. Customers should obtain the latest relevant information and data sheets before placing orders and should verify that such information is current and complete. Richtek cannot assume responsibility for use of any circuitry other than circuitry entirely embodied in a Richtek product. Information furnished by Richtek is believed to be accurate and reliable. However, no responsibility is assumed by Richtek or its subsidiaries for its use; nor for any infringements of patents or other rights of third parties which may result from its use. No license is granted by implication or otherwise under any patent or patent rights of Richtek or its subsidiaries.

X-ON Electronics

Largest Supplier of Electrical and Electronic Components

Click to view similar products for [Isolated DC/DC Converters](#) category:

Click to view products by [Richtek](#) manufacturer:

Other Similar products are found below :

[FMD15.24G](#) [PSL486-7LR](#) [Q48T30020-NBB0](#) [18362](#) [JAHW100Y1](#) [SPB05C-12](#) [SQ24S15033-PS0S](#) [19-130041](#) [CE-1003](#) [RDS180245](#)
[MAU228](#) [J80-0041NL](#) [DFC15U48D15](#) [XGS-1205](#) [NCT1000N040R050B](#) [SPB05B-15](#) [SPB05C-15](#) [L-DA20](#) [DCG40-5G](#) [QME48T40033-](#)
[PGB0](#) [AK1601-9RT](#) [DPA423R](#) [VI-R5022-EXWW](#) [PSC128-7iR](#) [RPS8-350ATX-XE](#) [DAS1004812](#) [PQA30-D24-S24-DH](#) [vi-m13-cw-03](#) [VI-](#)
[LN2-EW](#) [VI-PJW01-CZY](#) [CK2540-9ERT](#) [AK-1615-7R](#) [700DNC40-CON-KIT-8G](#) [350DNC40-CON-KIT-9G](#) [088-101348-G](#) [VI-L52-EW](#)
[VI-L53-CV](#) [PQA30-D48-S12-TH](#) [VI-L50-IY](#) [VI-LC63-EV](#) [AM2D-051212DZ](#) [24IBX15-50-0ZG](#) [HZZ01204-G](#) [SPU02L-09](#) [SPU02M-09](#)
[SPU02N-09](#) [UNO-PS/350-900DC/24DC/60W](#) [QUINT4-BUFFER/24DC/20](#) [QUINT4-CAP/24DC/5/4KJ](#) [QUINT4-CAP/24DC/10/8KJ](#)