

RTC7641

2.4 – 2.5 GHz 256 QAM High Power Wireless LAN Amplifier



JUN 2019 - Ver. 1.0

Description

The RTC7641 is a high power wireless LAN amplifier (PA) designed for 256 QAM applications over 2.4 ~ 2.5 GHz frequency range. The amplifier consists of 3 gain stages with inter-stage matching, built-in input matching network, and a power detector for close loop power control operation. The device is provided in an industrial standard 16-lead surface mount package QFN-3.0mm x 3.0mm x 1.0mm (max).

Functional Block Diagram

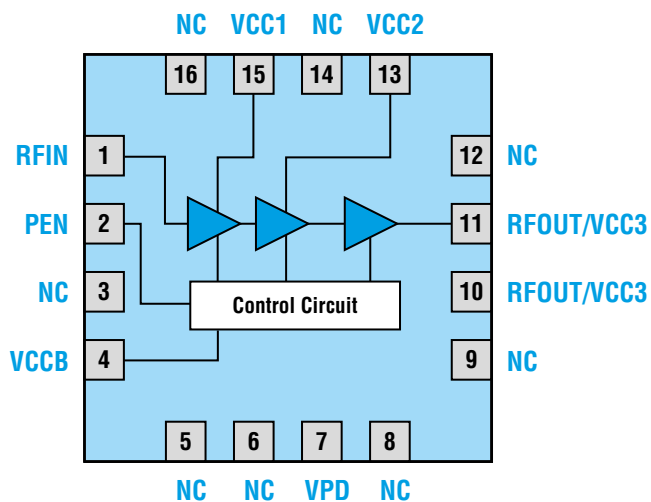

Features

- Frequency Range: 2.4 – 2.5 GHz
- Voltage Supply : 5 V
- High Gain : 32 dB
- +24 dBm linear output power for 802.11ac, MCS9, HT40, -35 dB DEVM
- +26 dBm linear output power for 802.11n, MCS7, HT40, -30 dB DEVM
- On-chip Input Matching
- 16L QFN-3.0mm x 3.0mm x 1.0mm (max) Package
- RoHS Compliant, Pb-free, Halogen Free
- Moisture Sensitivity Level : MSL 3

Applications

- High Power WLAN Applications
- IEEE 802.11b/g/n Wireless LAN Systems
- IEEE 802.11ac 256QAM Wireless LAN
- 2.4 GHz ISM Band Applications
- 2.4 GHz Cordless Phones

Pin Assignments

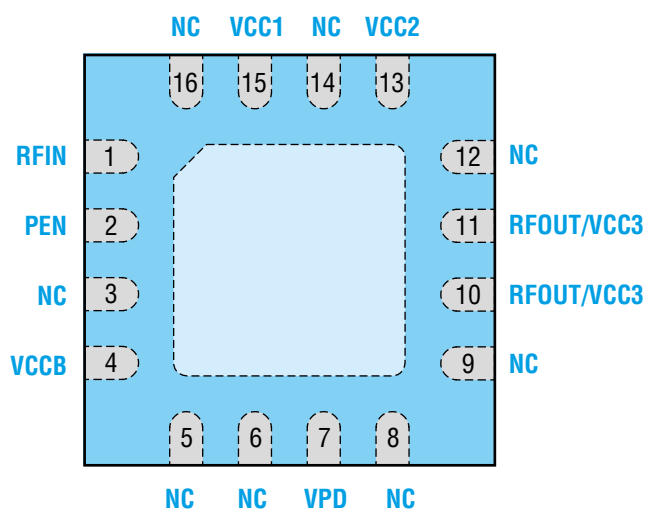

Top View Through Package

Pin No.	Pin Name	Description
1	RFIN	RF input. Input matching network is built on chip
2	PEN	PA control voltage for 1st, 2nd & 3rd stage
4	VCCB	Power supply for PA control circuit
7	VPD	Detector output voltage for output power index
10	RFOUT/VCC3	RF output & power supply for stage-3 (Vcc3)
11	RFOUT/VCC3	Same as Pin 10
13	VCC2	Power supply for power stage-2
15	VCC1	Power supply for power stage-1
3, 5, 6, 8, 9, 12, 14, 16	NC	Not connected inside the package For the best performance please connect these pins to ground on PCB
Exposed Paddle		It must be connected to a ground through PCB via for best performance

Absolute Maximum Ratings

Parameter	Symbol	Ratings	Unit
Supply Voltage	V _{CC}	5.5	V
PA Control Voltage	PEN	3.6	V
RF Input Power (50Ω load)	P _{IN}	+15	dBm
Operating Ambient Temperature	T _A	-40 to +85	°C
Storage Temperature	T _{STG}	-40 to +150	°C

NOTE: Stresses above those conditions listed under Absolute Maximum Ratings may cause permanent damage to the device. This is a stress rating only. Functional operation of the device above those conditions indicated in the Absolute Maximum Ratings is not implied. The functional operation of the device at the conditions in between Recommended Operating Ranges and Absolute Maximum Ratings for extended periods may affect device reliability.

Recommended Operating Ranges

T_A = +25°C, V_{CC} = 5V

Parameter	Symbol	Min	Typ	Max	Unit
Supply Voltage	V _{CC1} , V _{CC2} , V _{CC3} , V _{CCB}	4.5	5	5.5	V
PA Control Voltage	PEN	2.4		3.4	V

NOTE: Recommended Operating Ranges indicate conditions for which the device is intended to be functional, but does not guarantee specific performance limits.

Electrical Specifications

$T_A = +25^\circ\text{C}$, $V_{cc1} = V_{cc2} = V_{cc3} = V_{ccb} = 5\text{ V}$, $PEN = 2.5\text{ V}$, unless otherwise noted

Parameter	Symbol	Test Condition	Min	Typ	Max	Unit
Frequency Range			2.4	–	2.5	GHz
Linear Output Power	Pout	802.11ac, MCS9, HT40, DEVM = -40 dB	21	23		dBm
		802.11ac, MCS9, HT40, DEVM = -35 dB	22	24		dBm
		802.11n, MCS7, HT40/20, DEVM = -30 dB	24	26		dBm
		802.11n, MCS0, HT20, spectral mask compliant	26	27.5		dBm
		802.11b DSSS 1Mbps spectral mask compliant	27	29		dBm
Small Signal Gain	G		30	32		dB
Gain Flatness	ΔG	Gain Variation Over the Full Band			1	dB
1dB Output Compression Point	P1dB	1 dB Power Compression		31		dBm
Input return loss	S11	at TX port	15	18		dB
Output return loss	S22	at ANT port	7	9		dB
2nd Harmonics	2fo	Pout = 26 dBm, CW without harmonic filter ^(*Note)		-16	-11	dBm/ MHz
3rd Harmonics	3fo			-31	-26	
Switch On/Off Time	ton, toff	50% Control to 90%/10% RF		0.38	0.50	μs
Rise Time	tr	10% to 90% RF		100	200	ns
Supply Current	Ioff	PEN = 0 V, No RF		0.42		mA
	Icq	Quiescent, No RF		275	320	mA
	Icc	Pout = 24 dBm		390	450	mA
	Icc	Pout = 27 dBm		480	520	mA
Control Current	I _{PEN}	Current at PEN, No RF		0.36		μA
Power Detector Output	Vpd	Pout = 0 dBm	0.09	0.16	0.23	V
		Pout = 5 dBm	0.11	0.19	0.27	V
		Pout = 24 dBm	0.61	0.69	0.77	V
		Pout = 27 dBm	0.77	0.85	0.93	V
Ruggedness	Ru	CW, P _{IN} = +12 dBm, load VSWR = 10:1	No Permanent Damage			
Stability	S	CW, Pout = +29dBm, 0.1 GHz ~ 20 GHz, load VSWR = 6:1	All non-harmonically related outputs less than -30.5 dBm/MHz			

NOTE : Apply external harmonic filter can further suppress harmonic less than -50dBm/MHz

Application Circuits

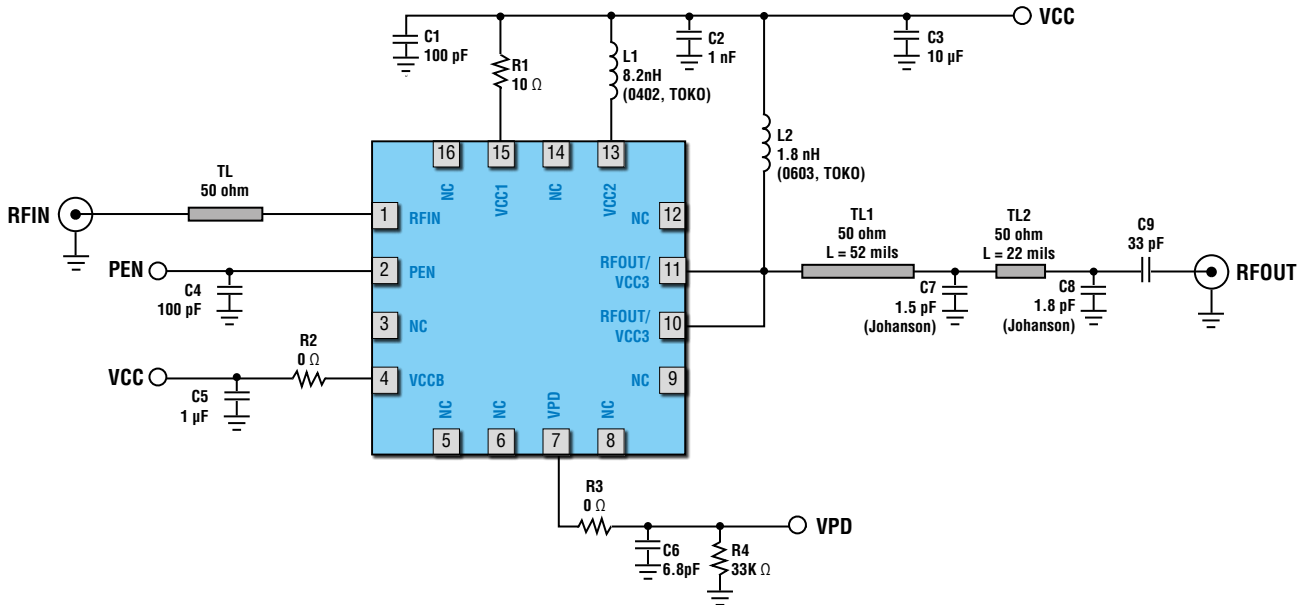

NOTE : Information in the above application is for reference only, and does not guarantee the mass production design of the device.

Evaluation Board Bill of Material

Component	Value	Description	Supplier	Part Number
IC		RTC7641	RichWave	
C1, C4	100 pF	De-coupling capacitor	Walsin	0402N101J500LT
C5	1 μF	De-coupling capacitor	Walsin	0402X105K6R3CT
C6	6.8 pF	De-coupling capacitor	Walsin	0402N6R8D500LT
C8	1.8 pF	Matching capacitor	Johanson	500R07S1R8CV4S
C7	1.5 pF	Matching capacitor	Johanson	500R07S1R5CV4S
C9	33 pF	DC blocking capacitor	Walsin	0402N330J500LT
C3	10 μF	De-coupling capacitor	Walsin	0603X106K6R3CT
C2	1 nF	De-coupling capacitor	Walsin	0402B102K500CT
R1	10 Ω		Walsin	WR04X10R0FTL
R2, R3	0 Ω		Walsin	WR04X00R0PTL
R4	33K Ω		Walsin	WR04X3302FTL
L1	8.2 nH	RF choke inductor	TOKO	LL1005-FHL8N2J
L2	1.8 nH	RF choke inductor	TOKO	LL1608-FSL1N8S

Recommended Footprint Patterns

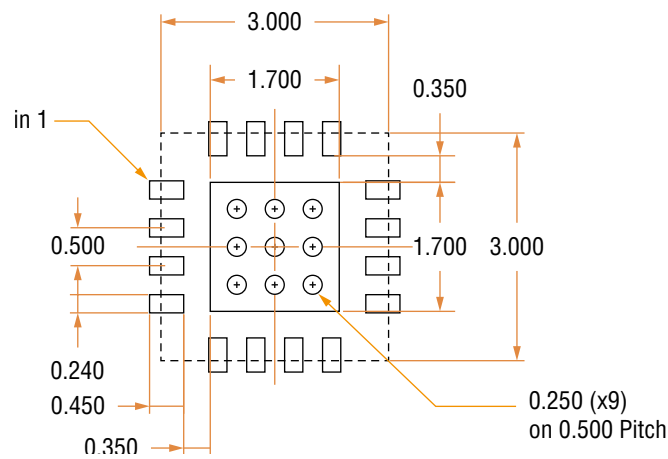

PCB Board Metal & Via Pattern

Top View

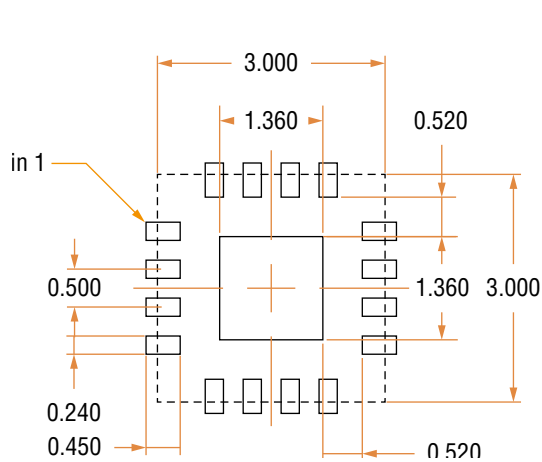

PCB Stencil Pattern

Top View

64% Solder Coverage on Pad

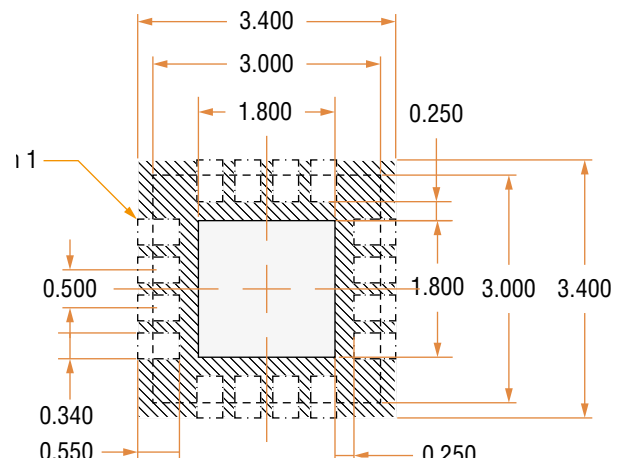

PCB Solder Mask Pattern

Top View

NOTE :

1. All dimensions are measured in millimeters.
2. Drawing is not to scale.

Package Dimensions

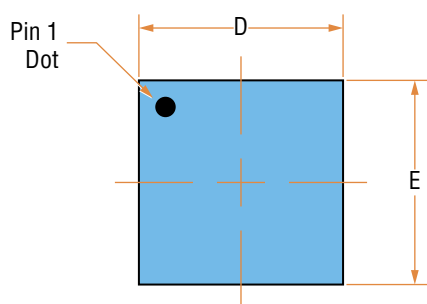

Top View

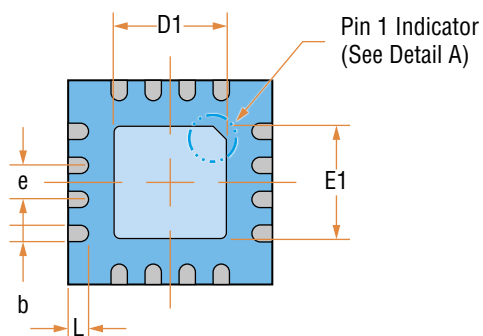

Bottom View

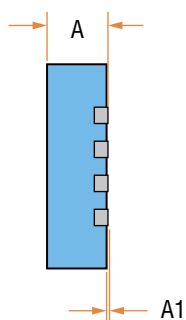

Side View

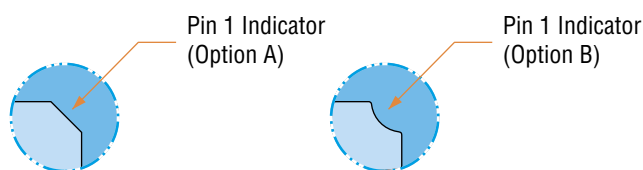

Detail A

16L QFN 3 X 3 X 1 - A		
SYMBOL	MIN	MAX
A	0.800	1.000
A1	0.000	0.050
b	0.180	0.300
D	2.900	3.100
D1	1.550	1.800
e	0.500TYP	
E	2.900	3.100
E1	1.550	1.800
L	0.200	0.400

NOTE :

1. All dimensions are measured in millimeters.
2. Drawing is not to scale.
3. The shape of the Pin 1 Indicator can be either Option A or Option B, but it must be located within the zone indicated.

Customer Service

RichWave Technology Corp.

3F, No.1, Alley 20, Lane 407, Sec.2, Tiding Bvd., Neihu Dist., Taipei City 114, Taiwan, R.O.C.

TEL +886-2-87511358 FAX +886-2-66006887

www.richwave.com.tw

Disclaimers

RichWave reserves the right to make changes without further notice to specifications and product descriptions in this document to improve reliability, function or design. RichWave does not assume any liability arising out of the application or use of information or product described in this document. Neither does RichWave convey any license under its intellectual property rights nor licenses to any of circuits described in this document to any third party.

The information in this document is believed to be accurate and reliable and is provided on an “as is” basis, without any express or implied warranty. Any information given in this document does not constitute any warranty of merchantability or fitness for a particular use. The operation of this product is subject to the user’s implementation and design practices. It is the user’s responsibility to ensure that equipment using this product is compliant to all relevant standards.

RichWave’s products are not designed or intended for use in life support equipment, devices or systems, or other critical applications, and are not authorized or warranted for such use.

Copyright © RichWave Technology Corp. All rights reserved.

X-ON Electronics

Largest Supplier of Electrical and Electronic Components

Click to view similar products for [Operational Amplifiers - Op Amps](#) category:

Click to view products by [RichWave](#) manufacturer:

Other Similar products are found below :

[430227FB](#) [AZV831KTR-G1](#) [UPC451G2-A](#) [UPC824G2-A](#) [LT1678IS8](#) [042225DB](#) [058184EB](#) [UPC822G2-A](#) [UPC258G2-A](#)
[NCS5651MNTXG](#) [NCV33202DMR2G](#) [NJM324E](#) [NTE925](#) [5962-9080901MCA*](#) [AP4310AUMTR-AG1](#) [HA1630D02MMEL-E](#)
[HA1630S01LPEL-E](#) [SCY33178DR2G](#) [NJU77806F3-TE1](#) [NCV5652MUTWG](#) [NCV20034DR2G](#) [LM2902EDR2G](#) [NTE778S](#) [NTE871](#)
[NTE924](#) [NTE937](#) [MCP6V16UT-E/OT](#) [MCP6V17T-E/MS](#) [MCP6V19T-E/ST](#) [SCY6358ADR2G](#) [LTC2065IUD#PBF](#) [NCS20282FCTTAG](#)
[LM4565FVT-GE2](#) [EL5420CRZ-T7A](#) [TSV791IYLT](#) [TSV772IQ2T](#) [TLV2772QPWR](#) [NJM2100M-TE1](#) [NJM4556AM-TE1](#) [MCP6487-E/SN](#)
[MCP6487-E/MS](#) [AS324MTR-E1](#) [AS358MMTR-G1](#) [MCP6232T-EMNY](#) [MCP662-E/MF](#) [TLC081AIP](#) [TLC082AIP](#) [TLE2074ACDW](#)
[TLV07IDR](#) [TLV2170IDGKT](#)