



日昇電子科技有限公司
深圳市丰华日昇科技有限公司

RI SHENG HI-TECH ELECTRICAL CO., LIMITED
TEL: 0755-29663560 FAX: 0755-29648851

承认书
Acknowledgment

CUSTOMER NAME 客户名称: _____
CUSTOMER PARTS NO 客户料号: _____
DESIGNATION 系列: _____
MODEL NO 型号: ST-1185SE
DRAWING NO 图型号: _____
FOR DRAWING ON 客户机种: _____



PLEASE CONFIRM OUR SPECIFICATION. 敬请确认规格书之内容。



PLEASE CONFIRM AND RETURN TO US. 请确认后惠返(1)份。

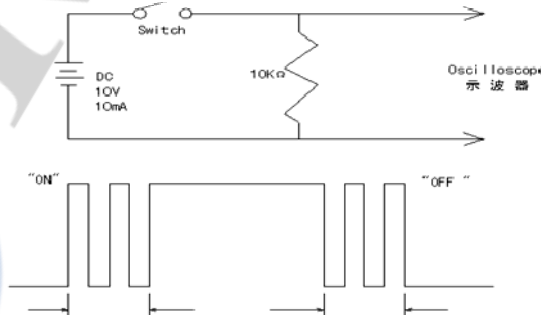

| | |
|--------------------|------------|
| APPROVAL STATUS 审批 | |
| APPROVED 接受 | FAILED 不接受 |
| SIGNATURE 签署 | DATE 日期 |

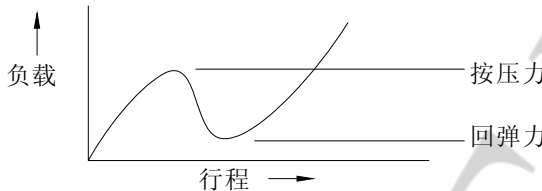

| | | | |
|----------|----------|----------|----|
| DGN 制表人 | CKD 校对 | APPD 审核 | |
| 刘丽 | 张伟 | | |
| DATE 日期/ | DATE 日期/ | DATE 日期/ | NO |

RI SHENG HI-TECH ELECTRICAL CO., LIMITED

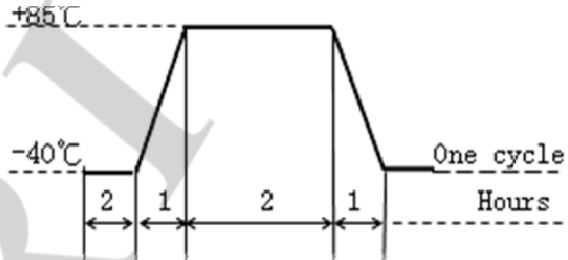
| | | | |
|-------------------------------------------------------------------------------------------------------------------------------------------------------------------------------------------------------------------------------------------------------------------------------------------------------------------------------------------------------------------------------------------------------------------------------------------------------------------------------------------------------------------------------------|-------------------------------|-----------------------------------------------------------------------------------------------------------------------------------------------|------------------------------------|
| 1. General specification 基本事项 | | | |
| 1.1 Switch action 开关种类: Tact Switch 轻触开关 | | | |
| 1.2 Switch rating 最大额定值: DC 12V, 50mA | | | |
| 1.3 Operation temperature range 使用温度试验范围: -20℃~+70℃ | | | |
| 1.4 Preservative temperature range 保存温度范围: -40℃~+85℃ | | | |
| 1.5 Appearance and dimensions : See outside drawing page 外形尺寸: 见外形尺寸图 | | | |
| 1.6 Standard condition :Unless otherwise specified ,the test and measurements shall be carried out as follows :试验、测定状态 Ambient temperature 温度: 5~35℃ Relative humidity 相对湿度: 45~85% Air pressure 气压: 86~106kPa(860~1060mbar) However ,if doubt arises on the decision based on the measured Values under the above-mentioned conditions ,the following conditions be employed: 但是在对判定产生疑义时,按下述状态实施: Ambient temperature 温度: 20±2℃ Relative humidity 相对湿度: 65±5% Air pressure 气压: 86~106kPa(860~1060mbar) | | | |
| 2. Performance 性能 | | | |
| 2.1 Electrical characteristics 电气性能 | | | |
| | Item 项目 | Test condition 测试条件 | Performance 规格 |
| 2.1.1 | Contact Resistance 接触电阻 | Push force: (Operation force)X2。 测定时的负荷: 操作方向动作力基准值的 2 倍 Measurement tool: Contact resistance meter 测定器: 微电流接触电阻计 (1kHz,20mV,5~50mA) | 100mΩ max. 100 毫欧以下。 |
| 2.1.2 | Insulation Resistance 绝缘电阻 | DC 250V(Between terminals) frame for 1 minute. 不相接的两端子间、端子与塑胶间施加 DC250V 电压,持续 1 分钟测量 | 100MΩ min. 100 兆欧以上。 |
| 2.1.3 | Withstand Voltage 耐电压 | AC 250V (Between terminals) frame for 1 minute. 不相接的两端子间、端子与塑胶间施加 AC250V 电压,持续 1 分钟测量 | No insulation destruction 无绝缘破坏 |
| 2.1.4 | Bouncing 触点抖动 | Operation speed:3~4times/s 操作速度: 每秒 3~4 次  | ON: 3ms max 以下 OFF: 8ms max 以下 |
|  日昇电子科技有限公司 RI SHENG HI-TECH ELECTRICAL CO., LIMITED | WRITTEN BY | CHECKED BY | APPROVED BY |
| | | | |

| 2.2 Mechanical Characteristics 机械性能 | | | |
|------------------------------------------------------------------------------------------------------------------------------------------|-----------------------------|------------------------------------------------------------------------------------------------------------------------------------------------------------------------------------------------------------------------------------------------------------------------------------------------------------------------|-------------------------------------------------------------------------------------------------------------------|
| Item 项目 | | Test condition 测试条件 | Performance 规格 |
| 2.2.1 | Operations Force 动作力 | Push by recommended operating condition. 测量时在开关的顶端的面中央、按开关动作方向均匀施加静负荷。  | Push force 按压力 1.57、2.57±0.47N (160、260±50gf) Return force 回弹力 0.5N (50gf 最小) |
| 2.2.2. | Travel to closure 运作行程 | Push by recommended operating condition $F=(\text{Operation force})\times 2$ 在开关的顶端的面中央沿开关动作方向施加2倍操作力测量行程，测量仪器的顶端应平。 | 0.2±0.1mm |
| 2.2.3 | Push strength 按压强度 | 30N (3Kgf) for 1 minute 在开关驱动器件顶端中央，在按压力方向加 30N (3Kgf) 压力，作用 60 秒。 | No damage(Electrical and mechanical) 无异常 (电气、机械性能) |
| 2.2.4 | Vibration test 耐振性 | 1) Amplitude 全振幅: 1.5mm 2) Sweep rate: 10-55-10Hz for 1 minute 扫描速度: 10-55-10Hz 1 分钟 3) Sweep method: Logarithmic frequency sweep rate 扫描方式: 对数频率扫描速度 4) Vibration direction : X、Y、Z (3 directions) 振动方向: X、Y、Z (3 方向) 5) Time: Each direction 2 hours (Total 6 hours) 时间: 每个方向 2 个小时 (共 6 小时) | No.2.1 and 2.2.1 to 2.2.2 shall be satisfied 满足 2.1 项和 2.2.1 至 2.2.2 项。 |
| 2.2.5 | Soldering heat test 耐焊接热 | Soldering area: t/2 of P.W.B thickness (P.C.B:T=1.6mm) 焊接面积: 印刷基板的 1/2 厚度处 Soldering temperature: 260±5℃ 焊接温度: 260±5℃ Soldering time: 3±0.5sec 焊接时间: 3±0.5 秒 | No damage (Electrical and mechanical) 无异常 (电气、机械性能) |
| 2.2.6 | Solderbility 可焊性 | After sprated flux 涂上助焊剂后 temperature: 245±5℃ 温度: 245±5℃ Soldering time: 3±0.5sec 焊接时间: 3±0.5 秒 | 90% or more of surface area of the portion immersed in solder shall be covered by new solder 90%或更多的浸焊面积能被焊锡覆盖 |
|  日昇电子科技有限公司 RISHENG HI-TECH ELECTRICAL CO., LIMITED | | WRITTEN BY | CHECKED BY |
| | | | APPROVED BY |

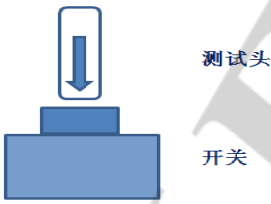
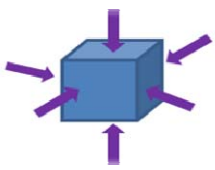
| 2.3 Climatic characteristics 耐候性能 | | | | |
|--------------------------------------------------------------------------------------------------------------------------------------------------|-----------------------------------|----------------------------------------------------------------------------------------------------------------------------------------------------------------------------------------------------------------------------------------------------------------------|------------------------------------------------------------------------------------------------------------------------------------------------------------------------------------------------------------------------------------------------------------------------------------------------|-------------|
| Item 项目 | | Test condition 测试条件 | Performance 规格 | |
| 2.3.1 | Cold test 耐寒性 | 1) Temperature: $-40\pm 2^{\circ}\text{C}$ 温度: $-40\pm 2^{\circ}\text{C}$ 2) Duration of test: 96h 持续时间: 96 小时 3) Take off a drop water 去掉水珠 4) Standard conditions after test: 1h 试验后的放置条件: 1 小时 | Contact resistance : $200\text{m}\Omega$ max 接触电阻: $200\text{m}\Omega$ 以下 Insulation resistance: $100\text{M}\Omega$ min 绝缘电阻: DC. 250V, 大于 $100\text{M}\Omega$ Withstand voltage :No. destruction. 耐电压: 无绝缘破坏。 No. 2.2.1 to 2.2.2 shall be satisfied 满足 2.2.1 到 2.2.2 项。 | |
| 2.3.2 | Heat test 耐热性 | 1) Temperature: $80\pm 2^{\circ}\text{C}$ 温度: $80\pm 2^{\circ}\text{C}$ 2) Duration of test: 96h 持续时间: 96 小时 3) Standard conditions after test :1h 试验后的放置条件: 1 小时 | Contact resistance : $200\text{m}\Omega$ max 接触电阻: $200\text{m}\Omega$ 以下 Insulation resistance: $100\text{M}\Omega$ min 绝缘电阻: DC. 250V, 大于 $100\text{M}\Omega$ Withstand voltage :No. destruction. 耐电压: 无绝缘破坏。 No. 2.2.1 to 2.2.2 shall be satisfied 满足 2.2.1 到 2.2.2 项。 | |
| 2.3.3 | TEMPERATURE CYCLIG TEST 温度交变试验 | According to following figure, after 5cycles, test after keeping in normal condition for 30min. 如图示环境中, 循环 5 次后, 放置在正常环境中, 1 小时后进行测量。  | Contact resistance : $200\text{m}\Omega$ max 接触电阻: $200\text{m}\Omega$ 以下 Insulation resistance: $100\text{M}\Omega$ min 绝缘电阻: DC. 250V, 大于 $100\text{M}\Omega$ Withstand voltage :No. destruction. 耐电压: 无绝缘破坏。 No. 2.2.1 to 2.2.2 shall be satisfied 满足 2.2.1 到 2.2.2 项 | |
| 2.3.4 | Humidity test 耐湿性 | 1) Temperature: $60\pm 2^{\circ}\text{C}$ 温度: $60\pm 2^{\circ}\text{C}$ 2) Relative humidity: 90~95% 相对湿度: 90~95% 3) Duration of test: 96h 持续时间: 96 小时 4) Take off a drop water 去掉水珠 5) Standard conditions after test: 1h 试验后的放置条件: 1 小时 | Contact resistance : $200\text{m}\Omega$ max 接触电阻: $200\text{m}\Omega$ 以下 Insulation resistance: $100\text{M}\Omega$ min 绝缘电阻: DC. 250V, 大于 $100\text{M}\Omega$ Withstand voltage :No. destruction. 耐电压: 无绝缘破坏。 No. 2.2.1 to 2.2.2 shall be satisfied 满足 2.2.1 到 2.2.2 项 | |
|  日昇电子科技有限公司 RI SHENG HI-TECH ELECTRICAL CO., LIMITED | | WRITTEN BY | CHECKED BY | APPROVED BY |

| Item 项目 | | Test condition 测试条件 | Performance 规格 | |
|------------------------------------------------------------------------------------------------------------------------------------------|-----------------------------------------------|---------------------------------------------------------------------------------------------------------------------------------------------------------------------------------------------------------------------------------------------------------------------------|--------------------------------------------------------------------------------------------------------------------------------------------------------------------------------------------------------------------------------------------------------------------------------------------------------------------------------------------------------------------------|-------------|
| 2.3.5 | Endurance (switching) action 耐久特性(开关寿命) | 1) Operation speed: 1time/s 动作速度: 1次/秒 2) Push force: Maximum value of operation force 按力: 动作力规格值的上限 3) Operation number: 100, 000 times 动作次数: 100, 000次 安装示意图  | Contact resistance : 200mΩ max 接触电阻: 200 mΩ 以下 Bouncing : 10 ms max 触点抖动: 10 毫秒以下 Insulation resistance: 100MΩ min 绝缘电阻: DC. 250V, 大于 100MΩ Withstand voltage :No. destruction. 耐电压: 无绝缘破坏。 Variations rate of operation force shall be within ±30% to the value before testing 动作力的变化范围在初始值的±30%以内 2.2.2 shall be satisfied 满足 2.2.2 项 | |
| 2.3.6 | Withstand H2S 耐 H2S | 1) Density: 3±1ppm 浓度: 3±1ppm 1) Temperature: 40±2℃ 温度: 40±2℃ 2) Relative humidity:90~95% 相对湿度: 90~95% 3) Duration of test: 12h 持续时间: 12 小时 4) Standard conditions after test:1h 试验后的放置条件: 1 小时 | Contact resistance : 200mΩ max 接触电阻: 200 mΩ 以下 Insulation resistance: 100MΩ min 绝缘电阻: DC. 250V, 大于 100MΩ Withstand voltage :No. destruction. 耐电压: 无绝缘破坏。 No.2.2.1 to 2.2.2 shall be satisfied 满足 2.2.1 到 2.2.2 项 | |
| 2.3.7 | Salt mist 雾实验 | At 5% Nacl liquor for 24 hours depend on 35℃, after washing ,keep in normal condition. 5% 的 Nacl 溶液, PH 值: 6.5~7.2, 在 35℃ 的条件下喷雾。铜材 24 小时, 铁材 8 小时。用清水洗干净后并在室温下晾干 | No remarkable corrosion shall be recognized in metal part. 在金属件上没有腐蚀斑点。 | |
| 2.3.8 | Shock 耐冲击性 | Peak acceleration: 500m/S ² 冲击加速度: 500m/S ² 脉冲持续时间 11ms Test time-6direction,each 3 times total 18 times 测试次数-6 个方向, 各 3 次共计 18 次  | Contact resistance : 200mΩ max 接触电阻: 200 mΩ 以下 Insulation resistance: 100MΩ min 绝缘电阻: DC. 250V, 大于 100MΩ Withstand voltage :No. destruction. 耐电压: 无绝缘破坏。 No.2.2.1 to 2.2.2 shall be satisfied 满足 2.2.1 到 2.2.2 项 | |
|  日昇电子科技有限公司 RISHENG HI-TECH ELECTRICAL CO., LIMITED | | WRITTEN BY | CHECKED BY | APPROVED BY |

| 3. Precaution 注意事项 | | | |
|----------------------------------------------------------------------------------------------------------------------------------------------------------------------------------------------------------------------------------------------------------------------------------------------------------------------------------------------------------------------------------------------|----------------------------------------------------------------------------------------------|------------|-------------|
| 3.1 Soldering condition 浸焊条件 | | | |
| Item 项目 | Condition 测试条件 | | |
| Preheat temperature 预热温度 | 110°C max (Embilmental temperature of soldering surface of P.C.B) 110°C 以下 (印刷基板焊锡周围的温度) | | |
| Preheat time 预热时间 | 60 sec, max 60 秒以内 | | |
| Area of flux 助焊剂面积 | 1/2 max of P.C.B. thickness 印刷基板厚度的 1/2 以内 | | |
| Temperature of solder 焊锡温度 | 260±5°C max 260±5°C 以下 | | |
| Times of immersion 浸焊时间 | Within 5 sec 5 秒以内 | | |
| Soldering number 浸焊次数 | Within 2 times (But should bring down heat of the first soldering) 2 次以内 (但应把第一次焊锡的温度降下来) | | |
| Printed wiring board 印刷基板 | Single sided copper- clad laminates 单面铜箔 | | |
| <p>1) After switches were soldered, please be careful not to clean switches with solvent 开关浸焊后, 注意不要用溶剂清洗。</p> <p>2) In the case of using soldering iron, soldering conditions shall be 280°C max and 3 sec max. 在使用烙铁的情况下, 焊锡温度应在 280°C 以下、3 秒以内。</p> <p>3) Right after switches were soldered; please be careful not to load on the knobs of switches. 浸焊后, 注意不要在手柄顶部施加负荷。</p> | | | |
| 3.2 Design instructions (设计中应注意事项) | | | |
| 1) Follow recommended P.C.B. piercing plan in the outside drawing page. 印刷基板的安装孔尺寸参见产品图 | | | |
| 3.3 Note (注意点) | | | |
| 1) Please be cautious not to give excessive static load or shock to switches. 注意不要施加超过负荷的压力或晃动开关。 | | | |
| 2) Please be careful not to pile up P.C.B. after switches were soldered. 开关焊接以后, 印刷基板注意不要叠放。 | | | |
| 3) Preservation under high temperature and high humidity or corrosive gas should be avoided especially. When you need to preserve for a long period, do not open the carton. 保管时尤其应注意避开高湿高温和有腐蚀性气体的环境, 如需长时间保存, 请不要打开包装箱。 | | | |
| 4) SMT 焊接时, 刷锡厚度应控制在 0.11mm 以内。 SMT were soldered., thickness control 0.11mm MAX | | | |
|  日昇电子科技有限公司 RI SHENG HI-TECH ELECTRICAL CO., LIMITED | WRITTEN BY | CHECKED BY | APPROVED BY |
| | | | |

4. Specification 材质

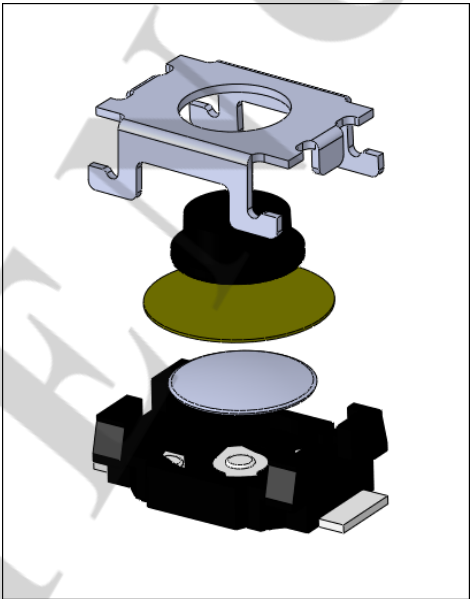
| NO | Part Name 名称 | QTY 数量 | Material 颜色 | Specification 材质 | Photos 照片 |
|----|-----------------|-----------|----------------|---------------------|------------------------------------------------------------------------------------|
| 1 | 盖板 | 1 | 本色 | 不锈钢 |  |
| 2 | 按钮 | 1 | 黑色 | LCP | |
| 3 | 防尘膜 | 1 | 黄色 | KTC | |
| 4 | 簧片 | 2 | 本色 | 不锈钢覆银 | |
| 5 | 基座 | 1 | 黑色 | LCP | |
| 6 | 端子 | 1 | 银白色 | 磷铜镀银 | |

5.Reel page 编带尺寸

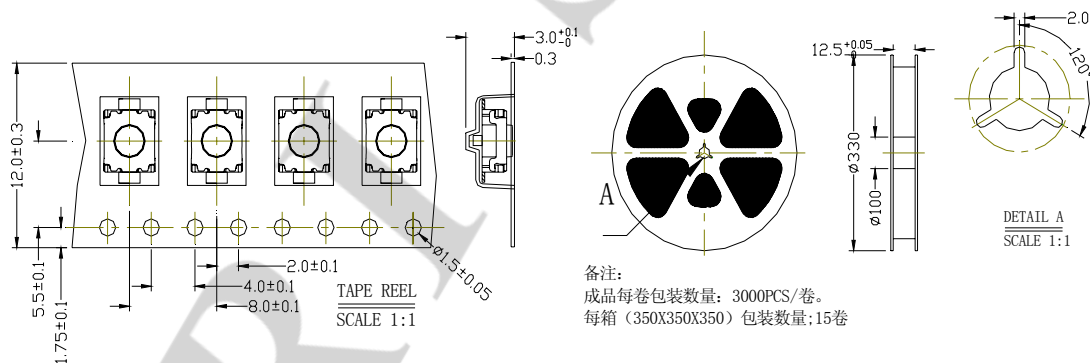

日昇电子科技有限公司
RI SHENG HI-TECH ELECTRICAL CO., LIMITED

WRITTEN BY

CHECKED BY

APPROVED BY

P. C. B MOUNTING PATTERN DIMENSION
 the following soldering are recommended
 for reflow soldering

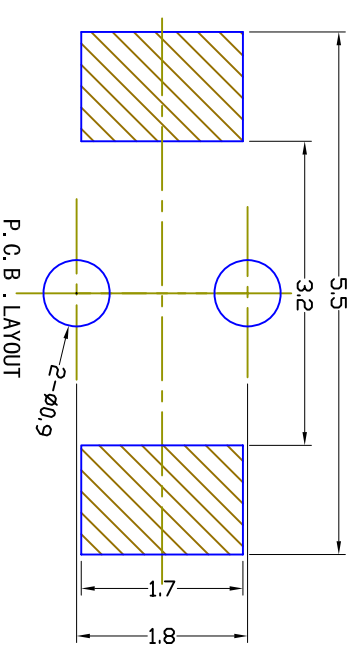

CIRCUIT DIAGRAM



技术参数

| NO | 项目 | 参数 |
|----|-------|-------------------|
| 1 | 额定电流 | 50mA 12V DC |
| 2 | 接触电阻 | ≤100mΩ |
| 3 | 按 触 力 | 160、260±50gf |
| 4 | 行 程 | 0.2±0.1mm |
| 5 | 绝缘电阻 | >100MΩ |
| 6 | 抗电强度 | AC 250V 50Hz 1Min |
| 7 | 寿 命 | 100, 000 cyc |

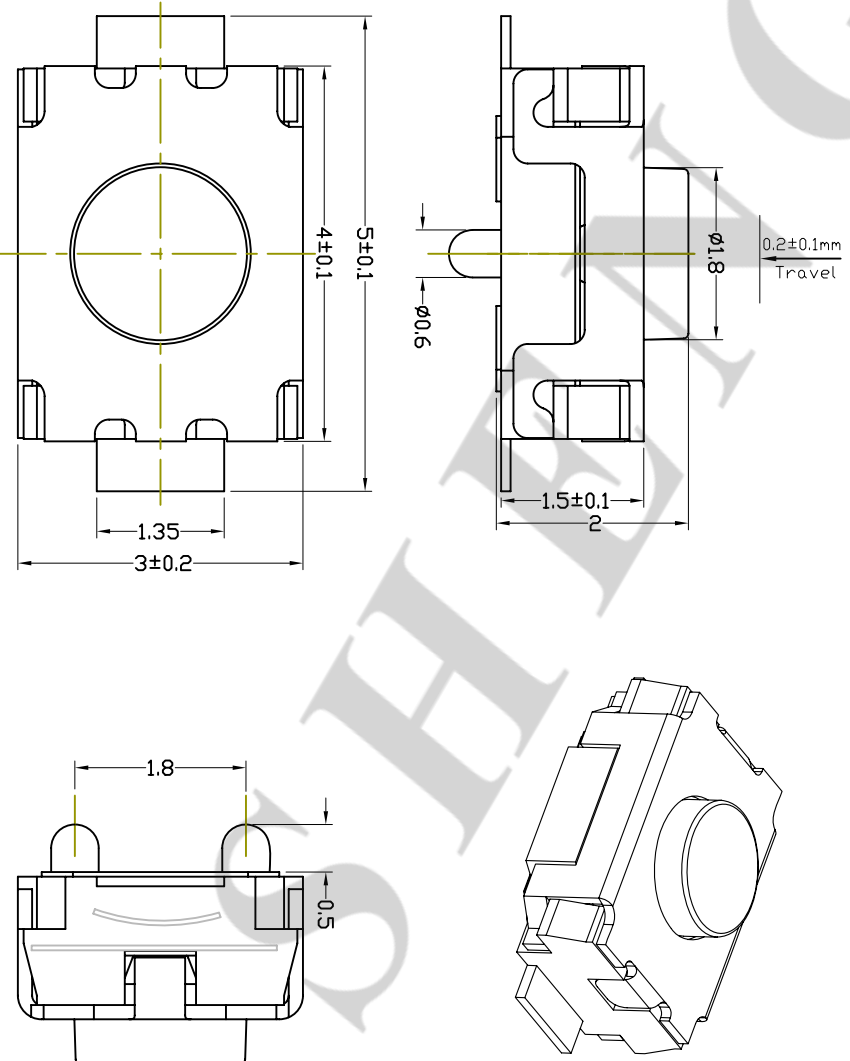

| | |
|----------|--|
| 信(通)用件登记 | |
| 描 图 | |
| 描 校 | |
| 旧底图总号 | |
| 底图总号 | |
| 签 字 | |
| 日 期 | |

| | | | | | | | | |
|-------|-----|-----|---------|-----|-----|-----|-----|-----------------------------------------------------------------|
| 更改文件号 | 标 记 | 日 期 | 变 更 内 容 | 担 当 | 审 核 | 批 准 | 角 度 | 未 注 公 差 |
| | | | | | | | | 30<L ±0.30 10<L≤30 ±0.20 5<L≤10 ±0.15 L≤5 ±0.10 ±2° |

| | | | |
|------|------------------|--------------------------------------------------------------|-----|
| | | 日昇电子科技有限公司 RISHENG HI-TECH ELECTRICAL CO., LIMITED | |
| 设计 | 20110515 | 单位 | 比例 |
| 审核 | | mm | 5:1 |
| 批准 | | | |
| 产品名称 | 轻触开关 TACT SWITCH | | |
| 产品型号 | ST-1185SE | | |

X-ON Electronics

Largest Supplier of Electrical and Electronic Components

Click to view similar products for [Tactile Switches](#) category:

Click to view products by [RI SHENG](#) manufacturer:

Other Similar products are found below :

[6407-250V-25273P](#) [ADTSA62NV](#) [B3F-3123](#) [1977177-8](#) [1977266-1](#) [ADTSA63NV](#) [ADTSM21NSVTR](#) [ADTSM25RVTR](#) [ADTSM32NVTR](#)
[ADTSMW64RV](#) [1977120-6](#) [FSMRA4JHA04](#) [GS4.70F300QP](#) [KSC241J SP DELTA LFS](#) [3FTL600RAS](#) [3FTL640RAS](#) [6407-250V-25343P](#)
[ADTSM31NVTR](#) [2-1977120-7](#) [TSJW-5.2-260-TR](#) [Y651050400P](#) [KMT011MNGJLHS](#) [70-201.0](#) [ADTSG648NV](#) [ADTSM62KSVTR](#)
[ADTSM648NV](#) [95C06E3RAT](#) [3ATH9Q](#) [FSMRA8JHA04](#) [HARS0073](#) [Y33R411N9FPLFT](#) [Y33R51139FPLFT](#) [Y31C01402FPLFS](#)
[PTS645SK50SMTR92](#) [ADTSM32NVB](#) [KMS233GPWTLFG](#) [Y78B64124FP](#) [Y31CJ244KFP LFS](#) [Y96D113G0FP LFS](#) [Y33A812C5FP LFT](#)
[Y56B2D120FP LFS](#) [Y31C5144KFP LFS](#) [PTS645 DVM83-BN125-2 LFS](#) [B3W 1000G](#) [KSC621G OL LFS](#) [B3F 1002C](#) [B3F 0047H](#) [B3W](#)
[1002C](#) [B3F 5001G](#) [B3W 1100C](#)