

# Quad ground sense operational amplifier

## BA10324A / BA10324AF / BA10324AFV

The BA10324A, BA10324AF, and BA10324AFV are monolithic ICs with four built-in operational amplifiers featuring internal phase compensation.

Either a dual or single power supply can be driven, and these products can be driven by a digital system 5V single power supply. These products can be used in a wide range of administrative and industrial applications, including transducer amplifiers and DC amplifiers.

### ●Applications

Ground sensing type pre-amplifiers  
Active filters  
DC amplifiers  
Pulse generators.

### ●Features

- 1) Wide range of operating power supply voltages and single power supply drive enabled.  
(single power supply: 3 to 32V, dual power supply:  $\pm 1.5$  to  $\pm 16$ V)
- 2) Common-mode input voltage can be operated from the ground level.
- 3) Differential input voltage can be operated up to the power supply voltage level.
- 4) Low current dissipation. ( $I_Q = 0.6\text{mA}$ )
- 5) Low offset voltage and offset current. ( $V_{IO} = 2\text{mV}$ ,  $I_{IO} = 5\text{nA typ.}$ )
- 6) Four operational amplifiers with phase compensation are built into the DIP / SOP Pin 14.
- 7) Compatible with model 324 operational amplifiers of other manufacturers.

### ●Block diagram

BA10324A / BA10324AF / BA10324AFV

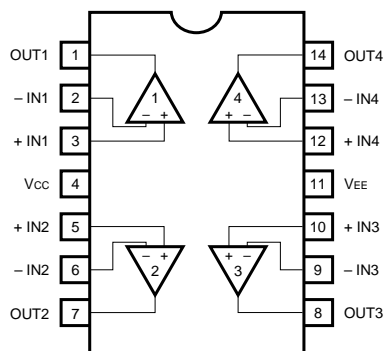

●Internal circuit configuration

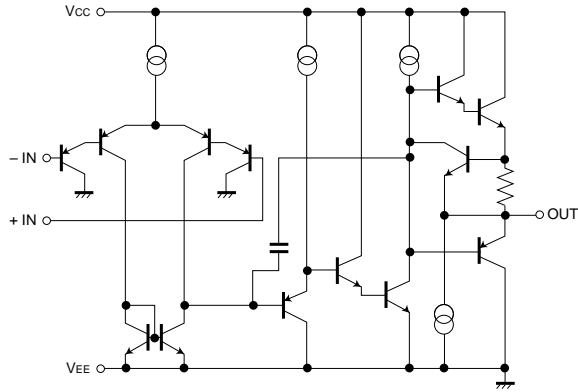

●Absolute maximum ratings (Ta = 25°C)

Parameter	Symbol	Limits			Unit
		BA10324A	BA10324AF	BA10324AFV	
Power supply voltage	V <sub>CC</sub>	32 ( ± 16)	32 ( ± 16)	32 ( ± 16)	V
Power dissipation	P <sub>d</sub>	950*	450*	400*	mW
Differential input voltage	V <sub>ID</sub>	± V <sub>CC</sub>	± V <sub>CC</sub>	± V <sub>CC</sub>	V
Common-mode input voltage	V <sub>I</sub>	- 0.3 ~ V <sub>CC</sub>	- 0.3 ~ V <sub>CC</sub>	- 0.3 ~ V <sub>CC</sub>	V
Operating temperature	T <sub>opr</sub>	- 40 ~ + 85	- 40 ~ + 85	- 40 ~ + 85	°C
Storage temperature	T <sub>stg</sub>	- 55 ~ + 125	- 55 ~ + 125	- 55 ~ + 125	°C

\* Refer to the Pd characteristics diagram.

The values for the are those when BA10324AF / BA10324AFV it is mounted on a glass epoxy board (50mm × 50mm × 1.6mm).

●Electrical characteristics (unless otherwise noted, Ta = 25°C, Vcc = 5V)

Parameter		Symbol	Min.	Typ.	Max.	Unit	Conditions
Input offset voltage		$V_{io}$	—	2	7	mV	$R_s = 50\Omega$
Input offset current		$I_{io}$	—	5	50	nA	
Input bias current		$I_b$	—	20	250	nA	*1
Common-mode input voltage		$V_{ICM}$	0	—	$V_{CC} - 1.5$	V	
Common-mode rejection ratio		CMRR	65	75	—	dB	
High-amplitude voltage gain		$A_{Vol}$	87	100	—	dB	$R_L \cong 2k\Omega, V_{CC} = 15V$
Power supply voltage rejection ratio		PSRR	65	100	—	dB	$R_s = 50\Omega$
Quiescent current		$I_q$	—	0.6	2.0	mA	$R_L = \infty$ , on All Op - Amps
Maximum output voltage		$V_{OH}$	$V_{CC} - 1.5$	—	—	V	$R_L = 2k\Omega$
		$V_{OL}$	—	—	0.25	V	$R_L = \infty$
Maximum output current	Source	$I_{OH}$	20	35	—	mA	$V_o = 0$
	Sink	$I_{OL}$	10	20	—	mA	$V_o = V_{CC}$
Channel separation		CS	—	120	—	dB	$f = 1kHz$ input conversion

\*1 Because the first stage is configured with a PNP transistor, input bias current is from the IC.

●Electrical characteristic curves

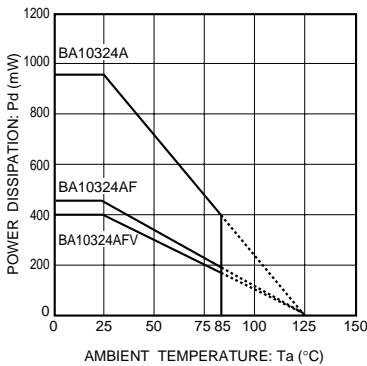

Fig.1 Power dissipation vs. ambient temperature

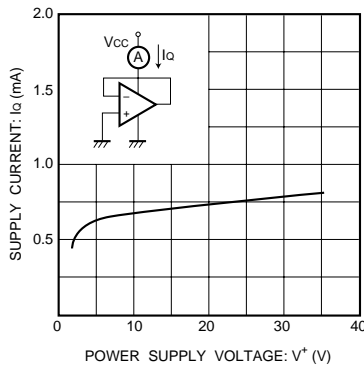

Fig.2 Quiescent current vs. power supply voltage

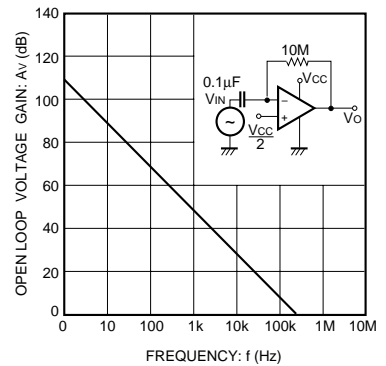

Fig.3 Open loop voltage gain vs. frequency

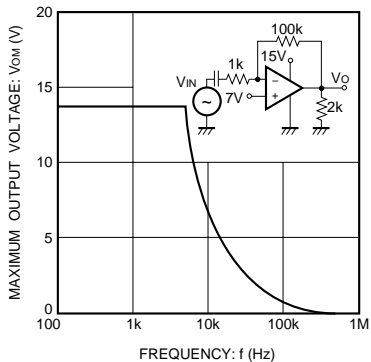

Fig.4 Maximum output voltage vs. frequency

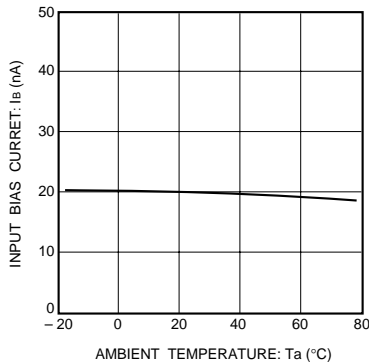

Fig.5 Input bias current vs. ambient temperature

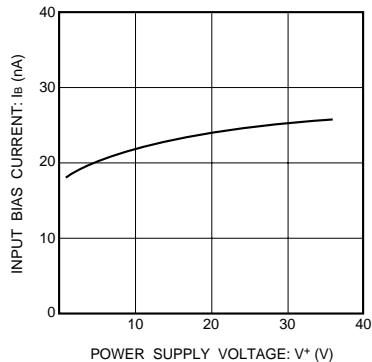

Fig.6 Input bias current vs. power supply voltage

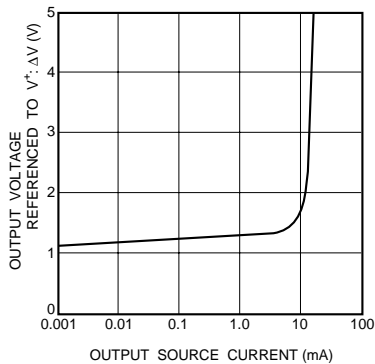

Fig.7 Potential difference during power supply output vs. output source current

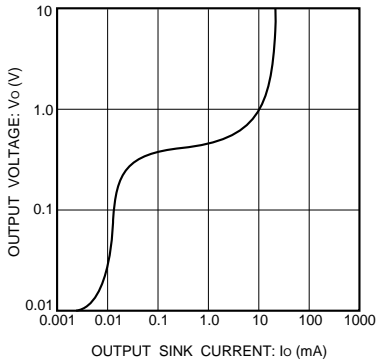

Fig.8 Output voltage vs. output sink current

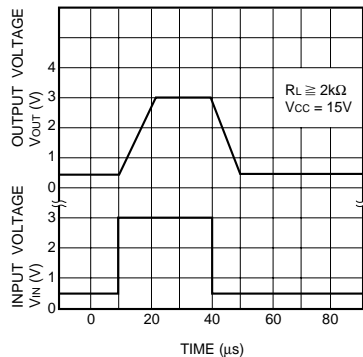

Fig.9 Output response characteristics

●Operation notes

(1) Unused circuit connections

If there are any circuits which are not being used, we recommend making connections as shown in Figure 10, with the non-inverted input pin connected to the potential within the in-phase input voltage range ( $V_{ICM}$ ).

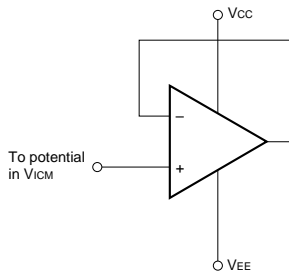
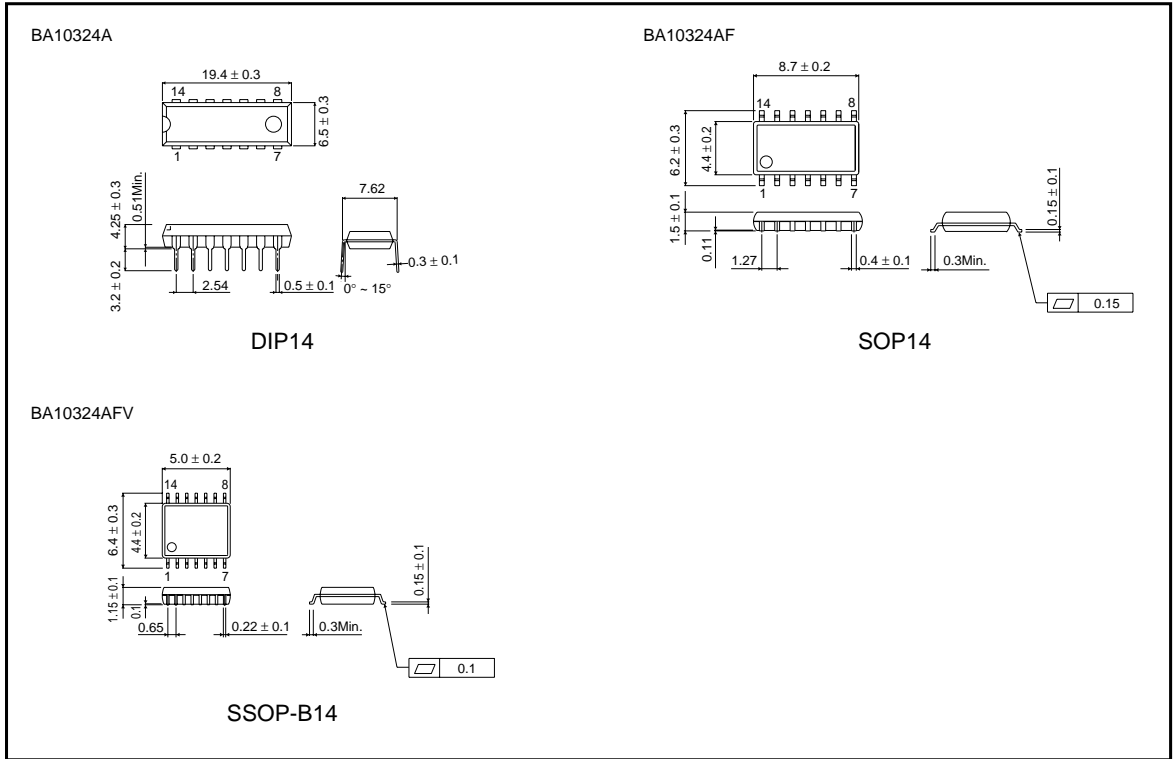

Fig.10 Unused circuit connections

●External dimensions (Units: mm)



## X-ON Electronics

Largest Supplier of Electrical and Electronic Components

*Click to view similar products for [Operational Amplifiers - Op Amps](#) category:*

*Click to view products by [ROHM](#) manufacturer:*

Other Similar products are found below :

[NCV33072ADR2G](#) [LM258AYDT](#) [LM358SNG](#) [430227FB](#) [UPC824G2-A](#) [LT1678IS8](#) [042225DB](#) [058184EB](#) [UPC822G2-A](#) [UPC259G2-A](#)  
[UPC258G2-A](#) [NCV33202DMR2G](#) [NTE925](#) [AZV358MTR-G1](#) [AP4310AUMTR-AG1](#) [HA1630D02MMEL-E](#) [HA1630S01LPEL-E](#)  
[SCY33178DR2G](#) [NJU77806F3-TE1](#) [NCV5652MUTWG](#) [NCV20034DR2G](#) [LM324EDR2G](#) [LM2902EDR2G](#) [NTE7155](#) [NTE778S](#) [NTE871](#)  
[NTE924](#) [NTE937](#) [MCP6V17T-E/MNY](#) [MCP6V19-E/ST](#) [MXD8011HF](#) [MCP6V16UT-E/OT](#) [MCP6V17T-E/MS](#) [MCP6V19T-E/ST](#)  
[SCY6358ADR2G](#) [ADA4523-1BCPZ](#) [LTC2065HUD#PBF](#) [ADA4523-1BCPZ-RL7](#) [2SD965T-R](#) [RS6332PXK](#) [BDM8551](#) [BDM321](#) [MD1324](#)  
[COS8052SR](#) [COS8552SR](#) [COS8554SR](#) [COS2177SR](#) [COS2353SR](#) [COS724TR](#) [LM2902M/TR](#)