

### General-purpose Operational Amplifier/Comparator



# Ground Sense Operational Amplifier

**BA10358F/FV, BA10324AF/FV, BA2904F/FV/FVM, BA2902F/FV/KN  
BA3404F/FVM**

#### ● Description

General-purpose BA10358/BA10324A family and high-reliability BA2904/BA2902 family integrate two independent Op-Amps and phase compensation capacitors on a single chip and have some features of high-gain, low power consumption, and operating voltage range of 3[V] to 32[V] (single power supply). BA3404 family is realized high speed operation and reduce the crossover distortions that compare with BA10358, BA2904.

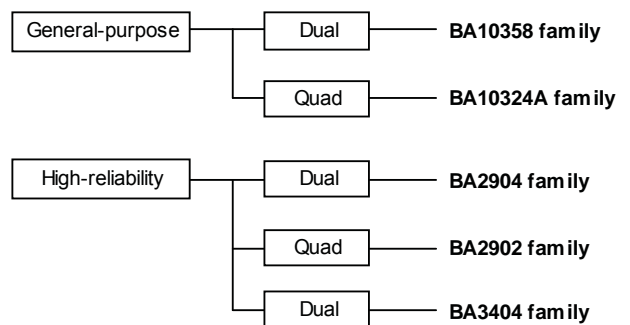

#### ● Features

- 1) Operable with a single power supply
- 2) Wide operating supply voltage  
+ 3.0[V] to + 32.0[V] (Single supply)  
(BA10358 / BA10324A / BA2904 / BA2902 family)  
+ 4.0[V] to + 36.0[V] (Single supply)  
(BA3404 family)
- 3) Standard Op Amp. Pin-assignments
- 4) Input and output are operable nearly GND level
- 5) Internal phase compensation type
- 6) Low supply current
- 7) High open loop voltage gain
- 8) Internal ESD protection  
Human body model (HBM) ±5000[V](Typ.)  
(BA2904/BA2902/BA3404 family)
- 9) Gold PAD (BA2904/BA2902/BA3404 family)
- 10) Wide temperature range  
- 40[°C] to + 125[°C]  
(BA2904/BA2902 family)  
- 40[°C] to + 85[°C]  
(BA10358/BA10324A/BA3404 family)

#### ● Pin Assignments

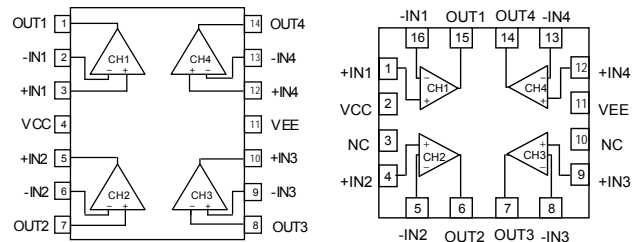
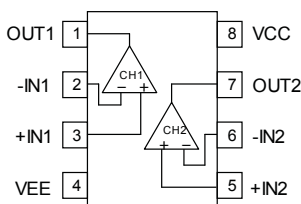

SOP8	SSOP-B8	MSOP8	SOP14	SSOP-B14	VQFN16
BA10358F	BA10358FV		BA10324AF	BA10324AFV	
BA2904F	BA2904FV	BA2904FVM	BA2902F	BA2902FV	BA2902KN
BA3404F		BA3404FVM			

● BA10358 family, BA10324A family

● Absolute maximum rating (Ta=25[°C])

Parameter	Symbol	Rating		Unit
		BA10358 family	BA10324A family	
Supply Voltage	VCC-VEE	+32		V
Differential Input Voltage(*1)	Vid	VCC – VEE		V
Input Common-mode voltage range	Vicm	VEE to VCC		V
Operating Temperature	Topr	-40 to +85		°C
Storage Temperature	Tstg	-55 to +125		°C
Maximum Junction Temperature	Tjmax	+125		°C

Note: Absolute maximum rating item indicates the condition which must not be exceeded.

Application of voltage in excess of absolute maximum rating or use out absolute maximum rated temperature environment may cause deterioration of characteristics.

(\*1) The voltage difference between inverting input and non-inverting input is the differential input voltage.

Then input terminal voltage is set to more than VEE.

● Electrical characteristics

Unless otherwise specified VCC=+5[V], VEE=0[V], Ta=25[°C]

Parameter	Symbol	Temperature Range	Guaranteed limit						Unit	Condition
			BA10358 family			BA10324A family				
			Min.	Typ.	Max.	Min.	Typ.	Max.		
Input offset voltage	Vio	25°C	-	2	7	-	2	7	mV	RS=50Ω
Input offset current	Iio	25°C	-	5	50	-	5	50	nA	-
Input Bias current	Ib	25°C	-	45	250	-	20	250	nA	-
Supply current	ICC	25°C	-	0.7	1.2	-	0.6	2	mA	RL=∞, All Op-Amps
High level output voltage	VOH	25°C	-	-	-	VCC-1.5	-	-	V	RL=2[kΩ]
Low level output voltage	VOL	25°C	-	-	-	-	-	250	mV	RL=2[kΩ]
Large signal voltage gain	AV	25°C	25	100	-	25	100	-	V/mV	RL≥2[kΩ], VCC=15[V]
Input common-mode voltage range	Vicm	25°C	0	-	VCC-1.5	0	-	VCC-1.5	V	-
Common-mode rejection ratio	CMRR	25°C	65	80	-	65	75	-	dB	-
Power supply rejection ratio	PSRR	25°C	65	100	-	65	100	-	dB	RS=50Ω
Output source current	IOH	25°C	10	20	-	20	35	-	mA	VIN+=1[V], VIN-=0[V], VOUT=0[V]
Output sink current	IOL	25°C	10	20	-	10	20	-	mA	VIN+=0[V], VIN-=1[V], VOUT=VCC
Output voltage range	Vo	25°C	0	-	VCC-1.5	-	-	-	V	RL=2[kΩ]
Channel separation	CS	25°C	-	120	-	-	120	-	dB	f=1[kHz], Input referred

(\*2) Current direction: Since first input stage is composed with PNP transistor, input bias current flows out of IC.

● BA2904 family, BA2902 family

● Absolute maximum rating (Ta=25°C)

Parameter	Symbol	Rating		Unit
		BA2904 family	BA2902 family	
Supply Voltage	VCC-VEE	+32		V
Differential Input Voltage(*1)	Vid	32		V
Input Common-mode voltage range	Vicm	(VEE-0.3) to VEE+32		V
Operating Temperature	Topr	-40 to +125		°C
Storage Temperature	Tstg	-55 to +150		°C
Maximum Junction Temperature	Tjmax	+150		°C

Note: Absolute maximum rating item indicates the condition which must not be exceeded.

Application of voltage in excess of absolute maximum rating or use out absolute maximum rated temperature environment may cause deterioration of characteristics.

(\*1) The voltage difference between inverting input and non-inverting input is the differential input voltage.

Then input terminal voltage is set to more than VEE.

● Electrical characteristics

Unless otherwise specified VCC=+5[V], VEE=0[V], Full range -40[°C] to +125[°C]

Parameter	Symbol	Temperature Range	Guaranteed limit						Unit	Condition
			BA2904 family			BA2902 family				
			Min.	Typ.	Max.	Min.	Typ.	Max.		
Input offset voltage (*2)	Vio	25°C	-	2	7	-	2	7	mV	VOUT=1.4[V]
		Full range	-	-	10	-	-	10		VCC=5 to 30[V], VOUT=1.4[V]
Temperature coefficient of Input offset voltage	$\Delta V_{io}/\Delta T$	-	-	±7	-	-	±7	-	µV/°C	VOUT=1.4[V]
Input offset current (*2)	Iio	25°C	-	2	50	-	2	50	nA	VOUT=1.4[V]
		Full range	-	-	200	-	-	200		
Temperature coefficient of Input offset current	$\Delta I_{io}/\Delta T$	-	-	±10	-	-	±10	-	pA/°C	VOUT=1.4[V]
Input bias current (*2)	Ib	25°C	-	20	250	-	20	250	nA	VOUT=1.4[V]
		Full range	-	-	250	-	-	250		
Supply current	ICC	25°C	-	0.7	1.2	-	0.7	2	mA	RL=∞ All Op-Amps
		Full range	-	-	2	-	-	3		
High level output voltage	VOH	25°C	3.5	-	-	3.5	-	-	V	RL=2[kΩ]
		Full range	27	28	-	27	28	-		VCC=30[V], RL=10[kΩ]
Low level output voltage	VOL	Full range	-	5	20	-	5	20	mV	RL=∞ All Op-Amps
Large signal voltage gain	AV	25°C	25	100	-	25	100	-	V/mV	RL ≥ 2[kΩ], VCC=15[V] VOUT=1.4 to 11.4[V]
Input common-mode voltage range	Vicm	25°C	0	-	VCC-1.5	0	-	VCC-1.5	V	(VCC-VEE)=5V, VOUT=VEE+1.4[V]
Common-mode rejection ratio	CMRR	25°C	50	80	-	50	80	-	dB	VOUT=1.4[V]
Power supply rejection ratio	PSRR	25°C	65	100	-	65	100	-	dB	VCC=5 to 30[V]
Output source current(*3)	IOH	25°C	20	30	-	20	30	-	mA	VIN+=1[V], VIN-=0[V], VOUT=0[V] Only 1ch is short circuit
		Full range	10	-	-	10	-	-		
Output sink current(*3)	IOL	25°C	10	20	-	10	20	-	mA	VIN+=0[V], VIN-=1[V], VOUT=5[V] Only 1ch is short circuit
		Full range	2	-	-	2	-	-		
	I <sub>sink</sub>	25°C	12	40	-	12	40	-	µA	VIN+=0[V], VIN-=1[V], VOUT=200[mV]
Channel separation	CS	25°C	-	120	-	-	120	-	dB	f=1[kHz], Input referred
Slew rate	SR	25°C	-	0.2	-	-	0.2	-	V/µs	VCC=15[V], AV=0[V], RL=2[kΩ], CL=100[pF]
Maximum frequency	ft	25°C	-	0.5	-	-	0.5	-	MHz	VCC=30[V], RL=2[kΩ], CL=100[pF]
Input referred noise voltage	Vn	25°C	-	40	-	-	40	-	nV/(Hz) <sup>1/2</sup>	VCC=15[V], VEE=-15[V], RS=100[Ω], Vi=0[V], f=1[kHz]

(\*2) Absolute value

(\*3) Under the high temperature environment, consider the power dissipation of IC when selecting the output current.

When the terminal shot circuits are continuously output, the output current is reduced to climb to the temperature inside IC.

● BA3404 family

● Absolute maximum rating (Ta=25°C)

Parameter	Symbol	Rating	Unit
Supply Voltage	VCC-VEE	+36	V
Differential Input Voltage(*1)	Vid	36	V
Input Common-mode voltage range	Vicm	(VEE-0.3) to VEE+36	V
Operating Temperature	Topr	-40 to +85	°C
Storage Temperature	Tstg	-55 to +150	°C
Maximum junction Temperature	Tjmax	+150	°C

Note: Absolute maximum rating item indicates the condition which must not be exceeded.

Application of voltage in excess of absolute maximum rating or use out absolute maximum rated temperature environment may cause deterioration of characteristics.

(\*1) The voltage difference between inverting input and non-inverting input is the differential input voltage.  
Then input terminal voltage is set to more than VEE.

● Electrical characteristics

Unless otherwise specified VCC=+15[V], VEE=-15[V], Ta=25°C

Parameter	Symbol	Temperature Range	Guaranteed limit			Unit	Condition
			Min.	Typ.	Max.		
Input offset voltage (*2)	Vio	25°C	-	2	5	mV	VOUT=0[V], Vicm=0[V]
Input offset current (*2)	Iio	25°C	-	5	50	nA	VOUT=0[V], Vicm=0[V]
Input bias current(*2)	Ib	25°C	-	70	200	nA	VOUT=0[V], Vicm=0[V]
Large signal voltage gain	AV	25°C	88	100	-	dB	RL ≥ 2[kΩ], VOUT=±10[V], Vicm=0[V]
Maximum output voltage	VOM	25°C	±13	±14	-	V	RL ≥ 2[kΩ]
Input common-mode voltage range	Vicm	25°C	-15	-	13	V	VOUT=0[V]
Common-mode rejection ratio	CMRR	25°C	70	90	-	dB	VOUT=0[V], Vicm=-15[V] to +13[V]
Power supply rejection ratio	PSRR	25°C	80	94	-	dB	Ri ≤ 10[kΩ], VCC=+4[V] to +30[V]
Supply current	ICC	25°C	-	2.0	3.5	mA	RL=∞ All Op-Amps, VIN+=0[V]
Output source current	Isource	25°C	20	30	-	mA	VIN+=1[V], VIN-=0[V], VOUT=+12[V], Only 1ch is short circuit
Output sink current	Isink	25°C	10	20	-	mA	VIN+=0[V], VIN-=1[V], VOUT=-12[V], Only 1ch is short circuit
Slew rate	SR	25°C	-	1.2	-	V/μs	AV=0[dB], RL=2[kΩ], CL=100[pF]
Unity gain frequency	ft	25°C	-	1.2	-	MHz	RL=2[kΩ]
Total harmonic distortion	THD	25°C	-	0.1	-	%	VOUT=10[Vp-p], f=20[kHz] AV=0[dB], RL=2[kΩ]

(\*2) Absolute value

● BA10358 family

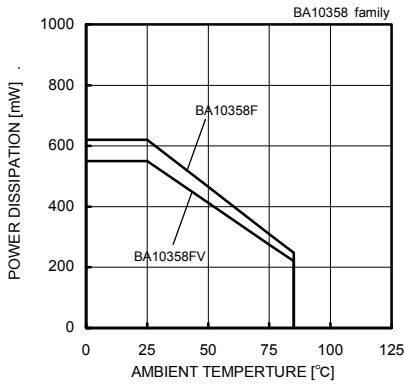

Fig.1  
Derating curve

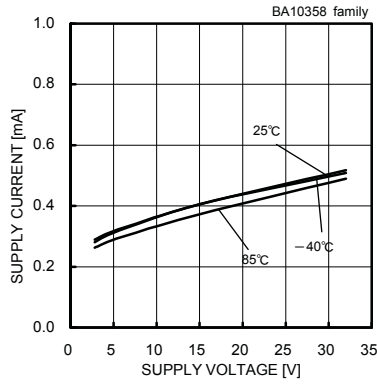

Fig.2  
Supply current - Supply voltage

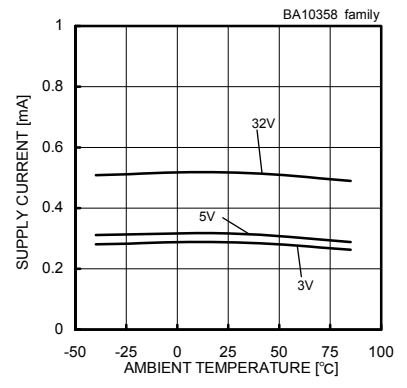

Fig.3  
Supply current - Ambient temperature

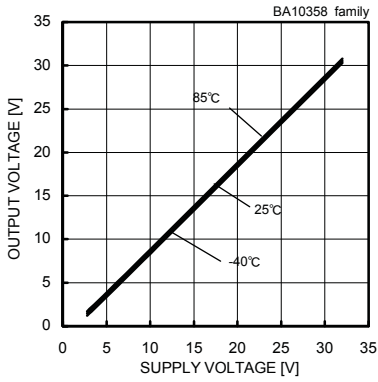

Fig.4  
High level output voltage - Supply voltage  
( $R_L=10[k\Omega]$ )

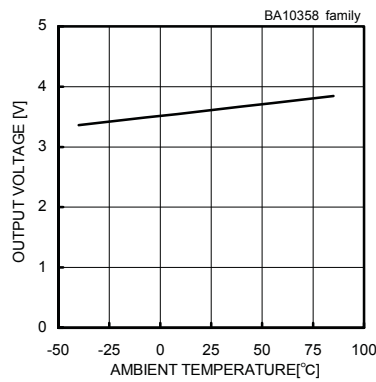

Fig.5  
High level output voltage - Ambient temperature  
( $V_{CC}=5[V]$ ,  $R_L=2[k\Omega]$ )

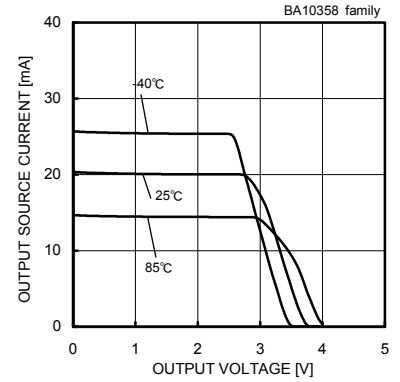

Fig.6  
Output source current - Output voltage  
( $V_{CC}=5[V]$ )

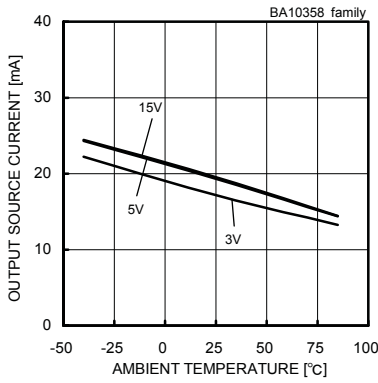

Fig.7  
Output source current - Ambient temperature  
( $V_{OUT}=0[V]$ )

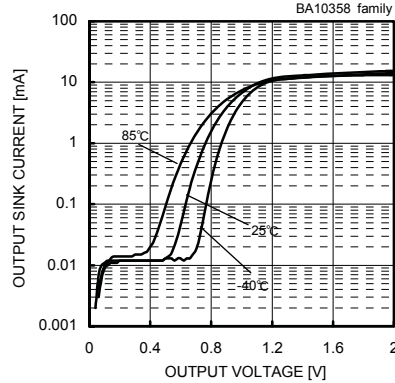

Fig.8  
Output sink current - Output voltage  
( $V_{CC}=5[V]$ )

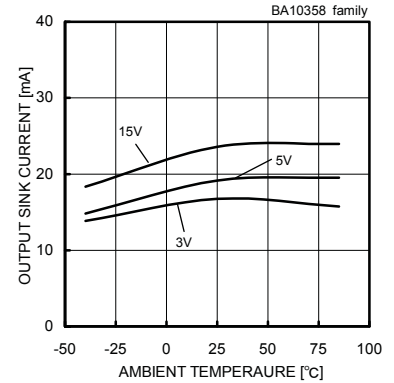

Fig.9  
Output sink current - Ambient temperature  
( $V_{OUT}=V_{CC}$ )

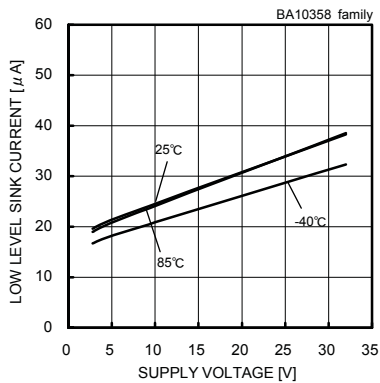

Fig.10  
Low level sink current - Supply voltage  
( $V_{OUT}=0.2[V]$ )

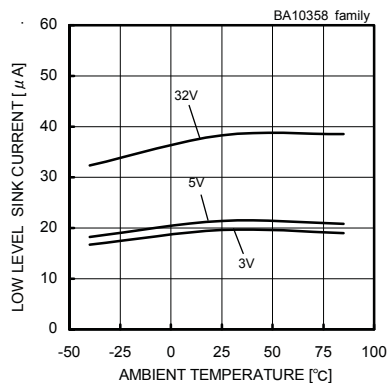

Fig.11  
Low level sink current - Ambient temperature  
( $V_{OUT}=0.2[V]$ )

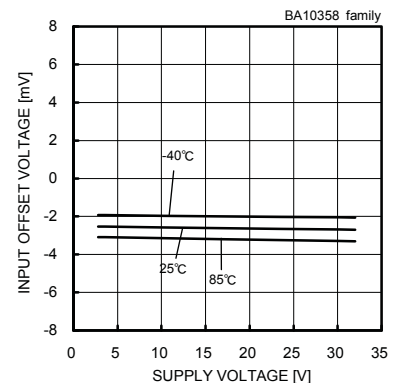
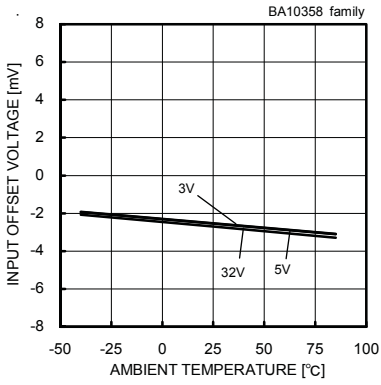

Fig.12  
Input offset voltage - Supply voltage  
( $V_{icm}=0[V]$ ,  $V_{OUT}=1.4[V]$ )

(\*) The above data is ability value of sample, it is not guaranteed.

● BA10358 family



**Fig. 13**  
Input offset voltage – Ambient temperature  
( $V_{icm}=0[V]$ ,  $V_{OUT}=1.4[V]$ )

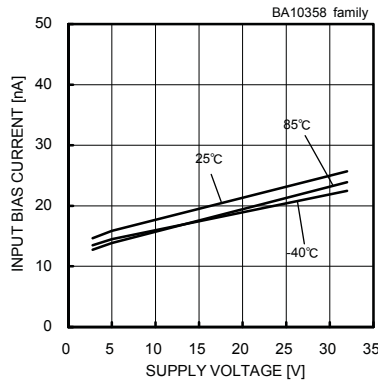

**Fig. 14**  
Input bias current – Supply voltage  
( $V_{icm}=0[V]$ ,  $V_{OUT}=1.4[V]$ )

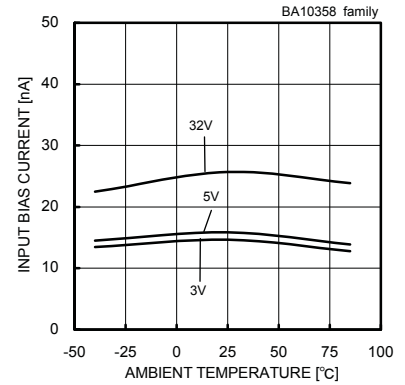

**Fig. 15**  
Input bias current – Ambient temperature  
( $V_{icm}=0[V]$ ,  $V_{OUT}=1.4[V]$ )

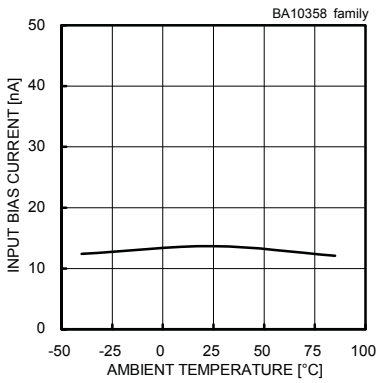

**Fig. 16**  
Input bias current – Ambient temperature  
( $V_{CC}=30[V]$ ,  $V_{icm}=28[V]$ ,  $V_{OUT}=1.4[V]$ )

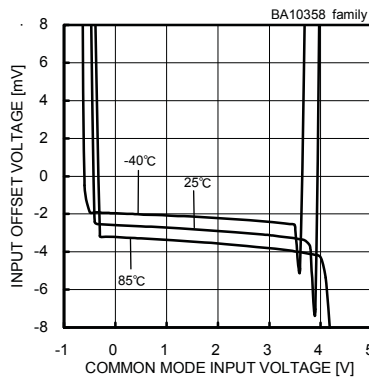

**Fig. 17**  
Input offset voltage – common-mode input voltage  
( $V_{CC}=5[V]$ )

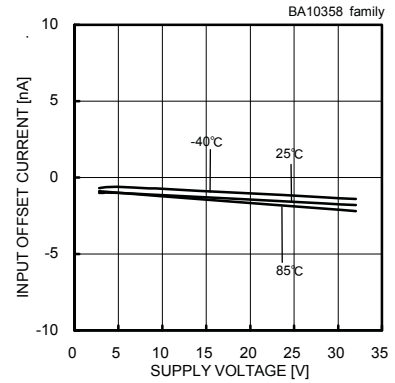

**Fig. 18**  
Input offset current – Supply voltage  
( $V_{icm}=0[V]$ ,  $V_{OUT}=1.4[V]$ )

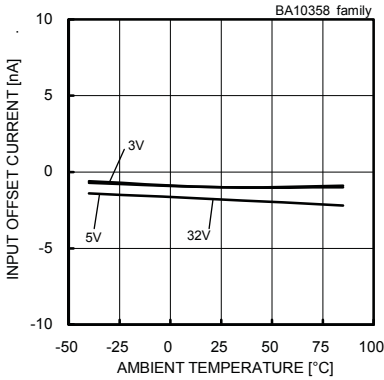

**Fig. 19**  
Input offset current – Ambient temperature  
( $V_{icm}=0[V]$ ,  $V_{OUT}=1.4[V]$ )

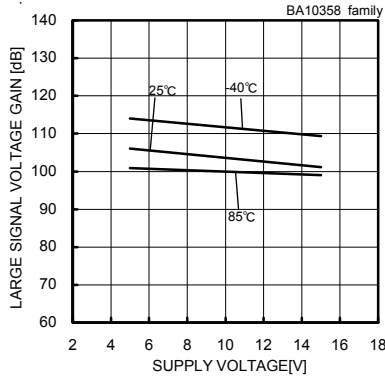

**Fig. 20**  
Large signal voltage gain – Supply voltage  
( $R_L=2[k\Omega]$ )

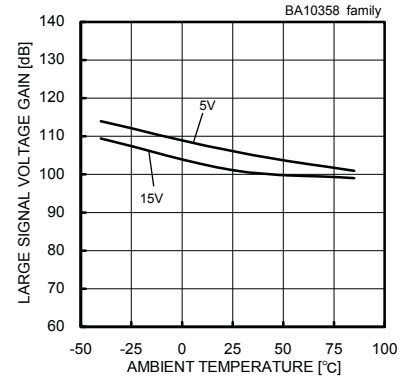

**Fig. 21**  
Large signal voltage gain – Ambient temperature  
( $R_L=2[k\Omega]$ )

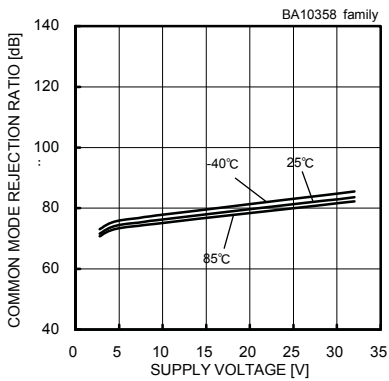

**Fig. 22**  
Common - mode rejection ratio – Supply voltage

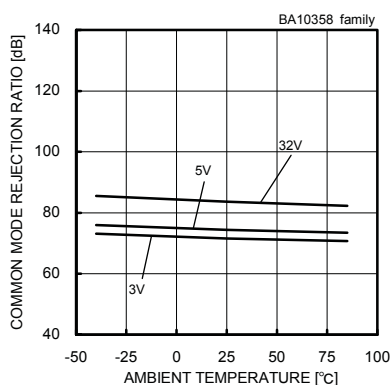

**Fig. 23**  
Common - mode rejection ratio  
- Ambient temperature

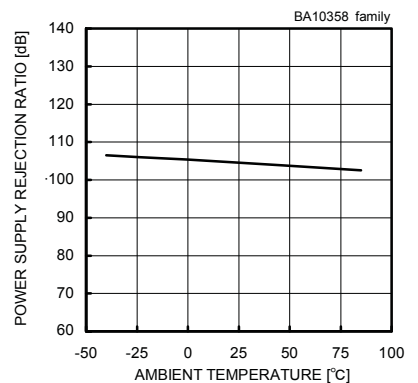

**Fig. 24**  
Power supply rejection ratio - Ambient temperature

(\*) The above data is ability value of sample, it is not guaranteed.

● BA10324A family

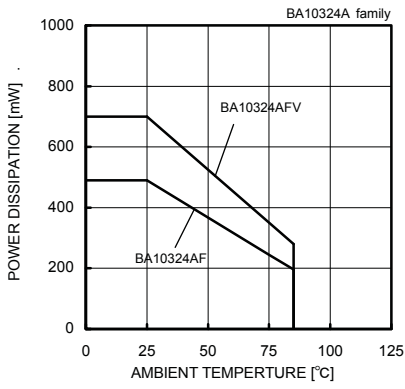

Fig.1 Derating curve

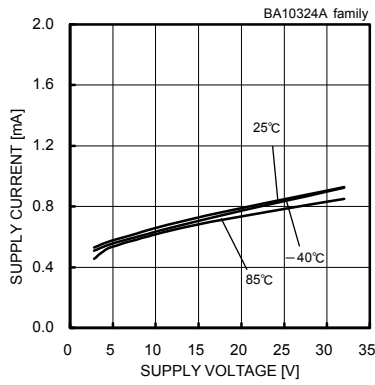

Fig.2 Supply current - Supply voltage

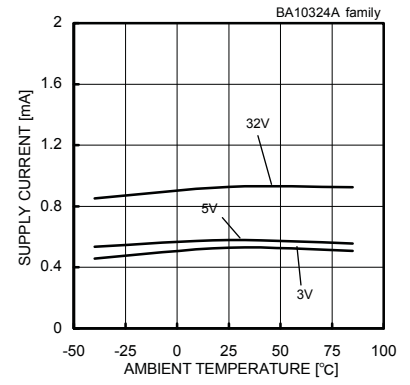

Fig.3 Supply current - Ambient temperature

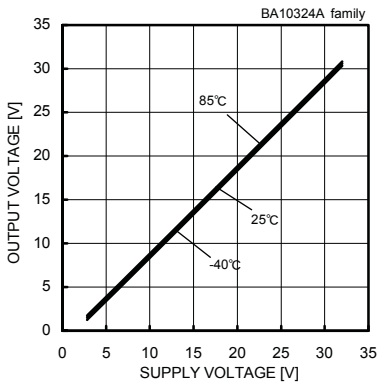

Fig.4 Output voltage - Supply voltage (RL=10[kΩ])

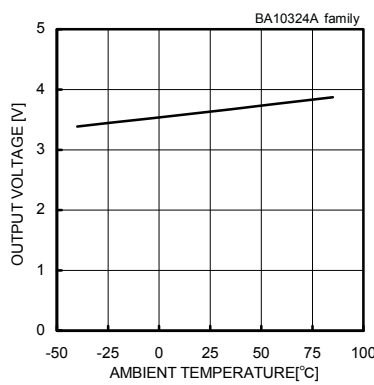

Fig.5 Output voltage - Ambient temperature (VCC=5[V], RL=2[kΩ])

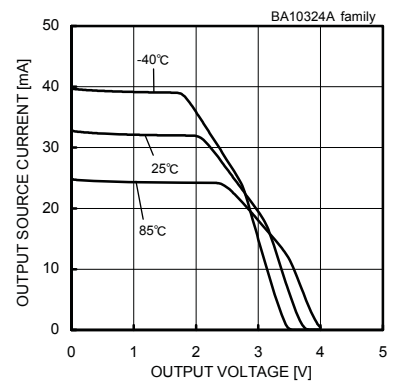

Fig.6 Output source current - Output voltage (VCC=5[V])

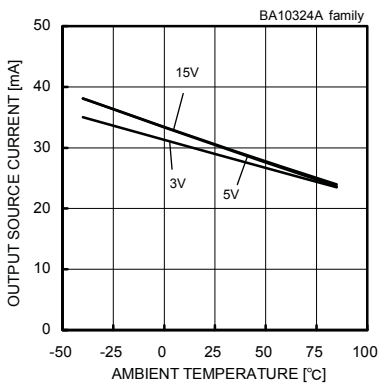

Fig.7 Output source current - Ambient temperature (VOUT=0[V])

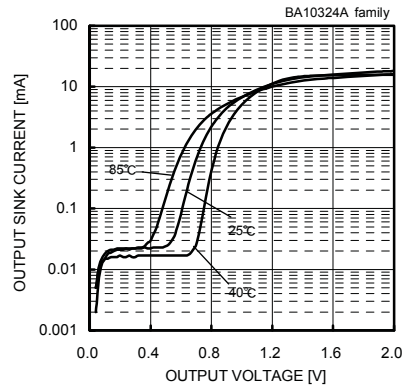

Fig.8 Output sink current - Output voltage (VCC=5[V])

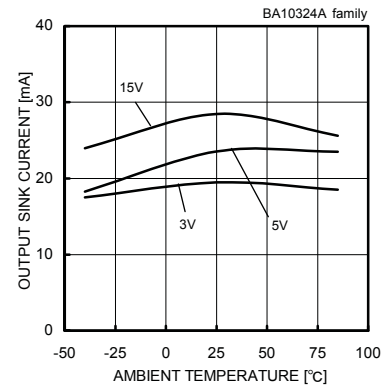

Fig.9 Output sink current - Ambient temperature (VOUT=VCC)

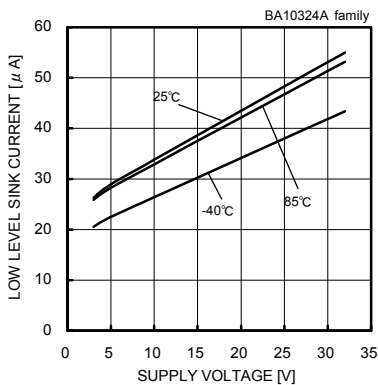

Fig.10 Low level sink current - Supply voltage (VOUT=0.2[V])

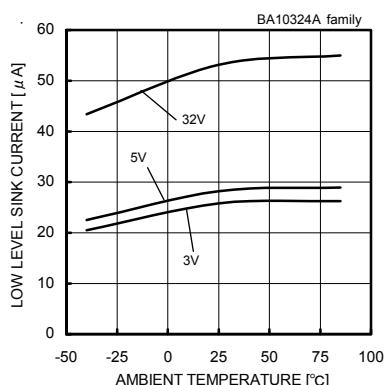

Fig.11 Low level sink current - Ambient temperature (VOUT=0.2[V])

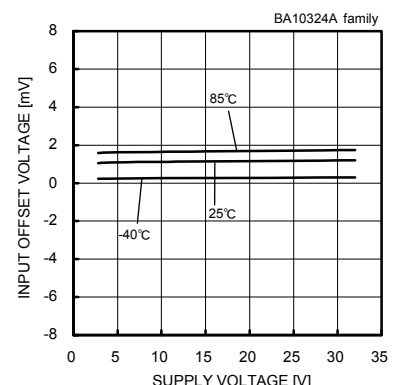
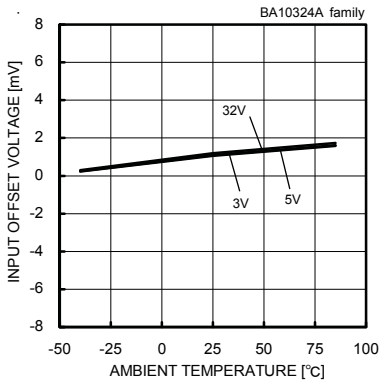

Fig.12 Input offset voltage - Supply voltage (VICM=0[V], VOUT=1.4[V])

(\*) The above data is ability value of sample, it is not guaranteed.

● BA10324A family



**Fig. 13**  
Input offset voltage – Ambient temperature  
( $V_{icm}=0[V]$ ,  $V_{OUT}=1.4[V]$ )

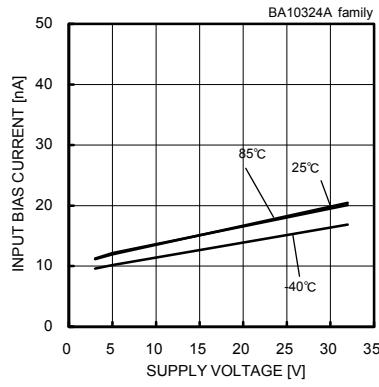

**Fig. 14**  
Input bias current – Supply voltage  
( $V_{icm}=0[V]$ ,  $V_{OUT}=1.4[V]$ )

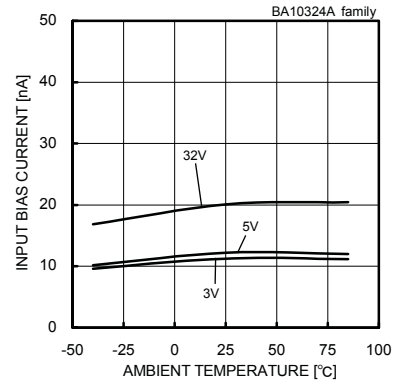

**Fig. 15**  
Input bias current – Ambient temperature  
( $V_{icm}=0[V]$ ,  $V_{OUT}=1.4[V]$ )

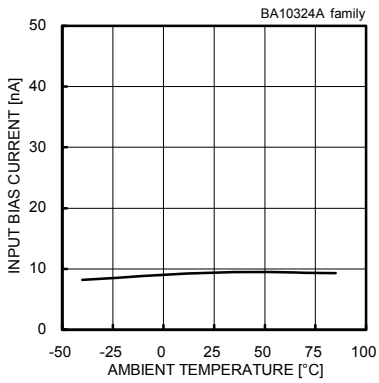

**Fig. 16**  
Input bias current – Ambient temperature  
( $V_{CC}=30[V]$ ,  $V_{icm}=28[V]$ ,  $V_{OUT}=1.4[V]$ )

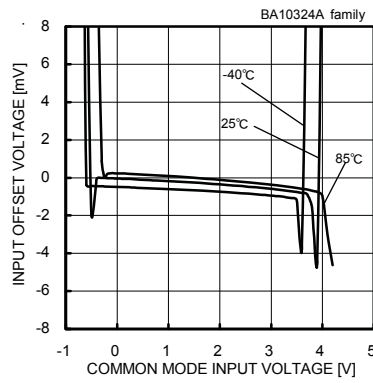

**Fig. 17**  
Input offset voltage – common-mode input voltage  
( $V_{CC}=5[V]$ )

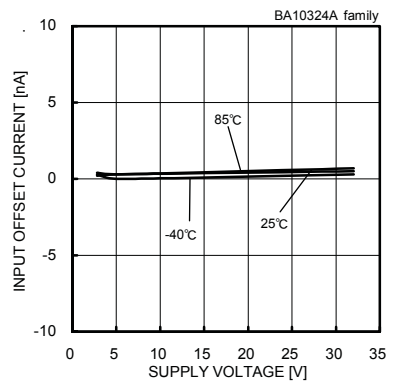

**Fig. 18**  
Input offset current – Supply voltage  
( $V_{icm}=0[V]$ ,  $V_{OUT}=1.4[V]$ )

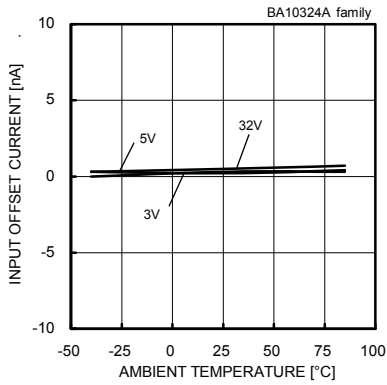

**Fig. 19**  
Input offset current – Ambient temperature  
( $V_{icm}=0[V]$ ,  $V_{OUT}=1.4[V]$ )

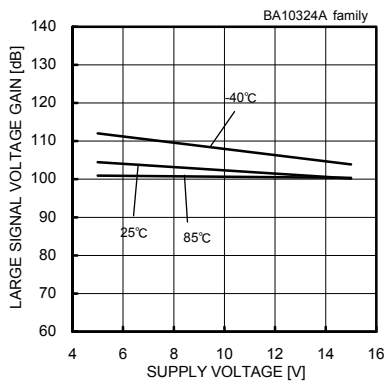

**Fig. 20**  
Large signal voltage gain – Supply voltage  
( $R_L=2[k\Omega]$ )

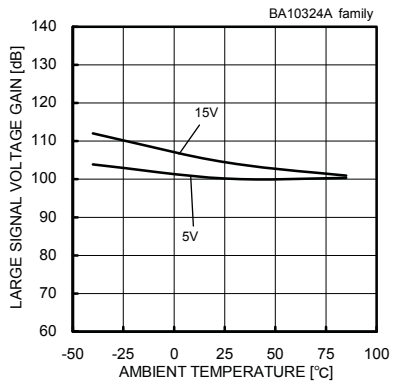

**Fig. 21**  
Large signal voltage gain – Ambient temperature  
( $R_L=2[k\Omega]$ )

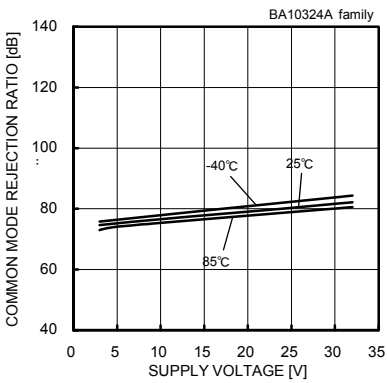

**Fig. 22**  
Common - mode rejection ratio – Supply voltage

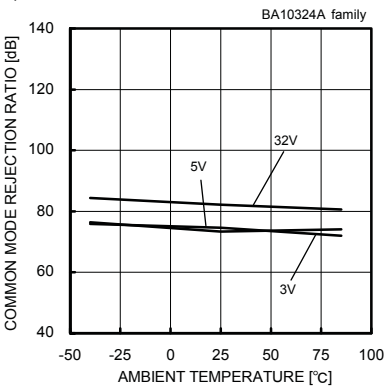

**Fig. 23**  
Common - mode rejection ratio - Ambient temperature

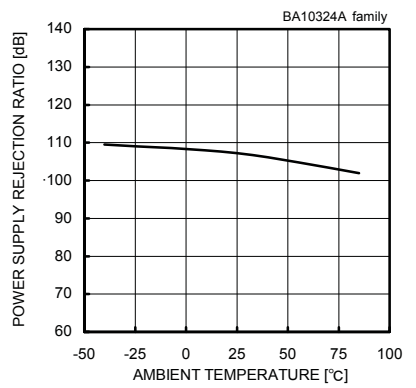

**Fig. 24**  
Power supply rejection ratio - Ambient temperature

(\*) The above data is ability value of sample, it is not guaranteed.



● BA2904 family

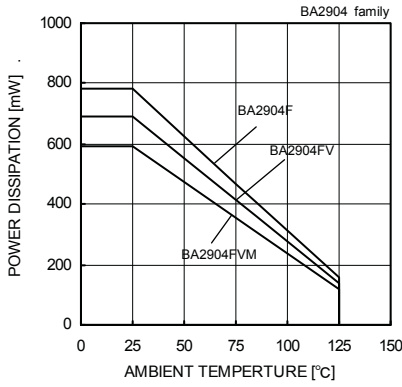

Fig.1  
Derating curve

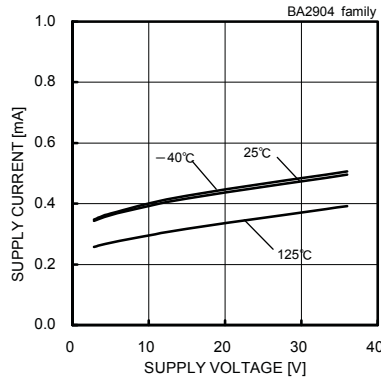

Fig.2  
Supply current - Supply voltage

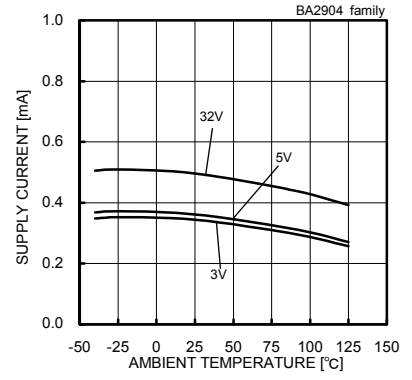

Fig.3  
Supply current - Ambient temperature

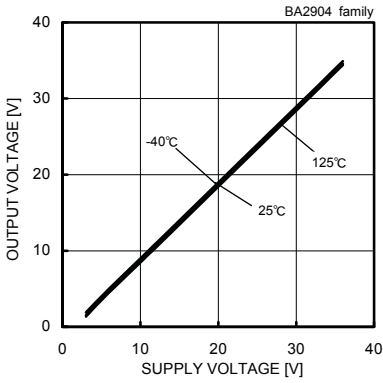

Fig.4  
Output voltage - Supply voltage  
( $R_L=10[k\Omega]$ )

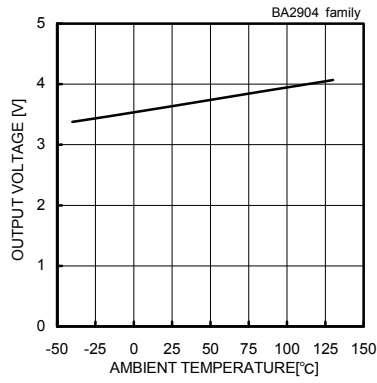

Fig.5  
Output voltage - Ambient temperature  
( $V_{CC}=5[V]$ ,  $R_L=2[k\Omega]$ )

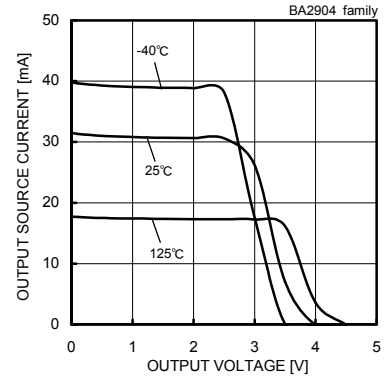

Fig.6  
Output source current - Output voltage  
( $V_{CC}=5[V]$ )

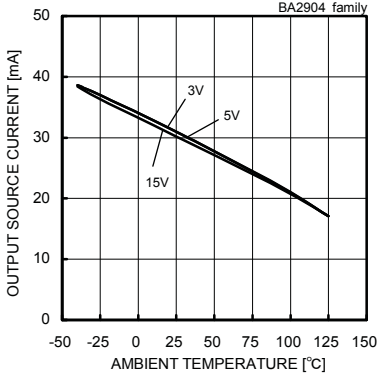

Fig.7  
Output source current - Ambient temperature  
( $V_{OUT}=0[V]$ )

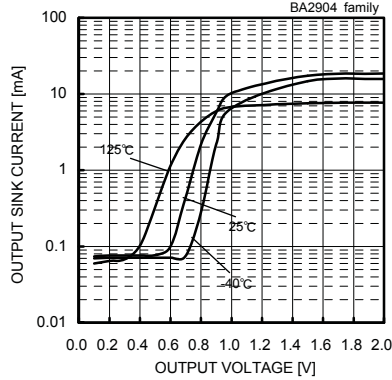

Fig.8  
Output sink current - Output voltage  
( $V_{CC}=5[V]$ )

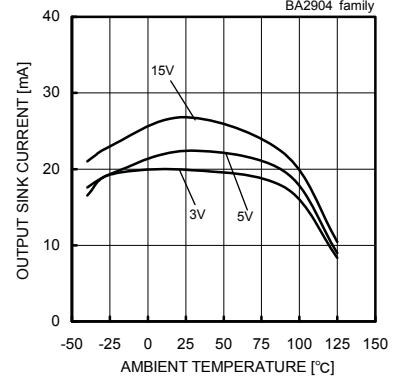

Fig.9  
Output sink current - Ambient temperature  
( $V_{OUT}=V_{CC}$ )

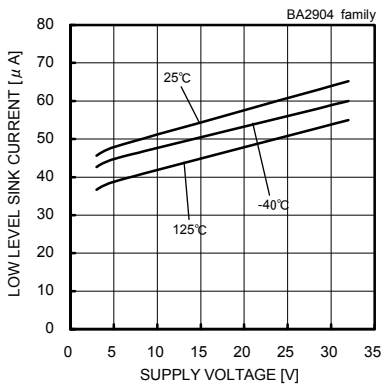

Fig.10  
Low level sink current - Supply voltage  
( $V_{OUT}=0.2[V]$ )

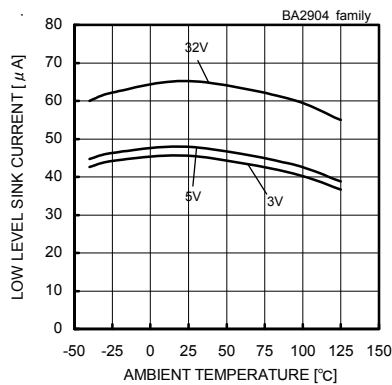

Fig.11  
Low level sink current - Ambient temperature  
( $V_{OUT}=0.2[V]$ )

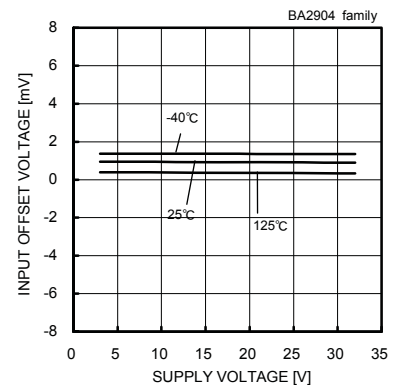
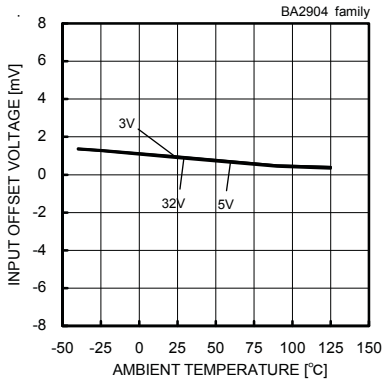

Fig.12  
Input offset voltage - Supply voltage  
( $V_{icm}=0[V]$ ,  $V_{OUT}=1.4[V]$ )

(\*) The above data is ability value of sample, it is not guaranteed.

● BA2904 family



**Fig. 13**  
Input offset voltage – Ambient temperature  
( $V_{icm}=0[V]$ ,  $V_{OUT}=1.4[V]$ )

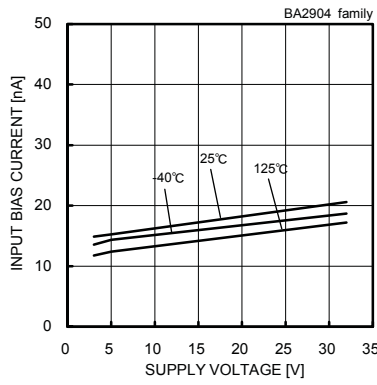

**Fig. 14**  
Input bias current – Supply voltage  
( $V_{icm}=0[V]$ ,  $V_{OUT}=1.4[V]$ )

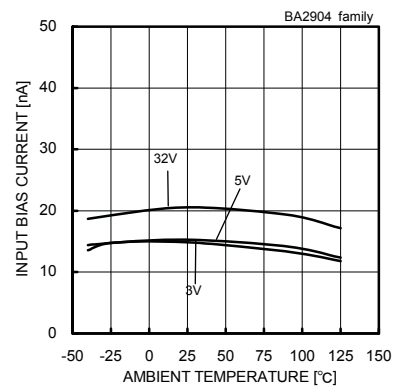

**Fig. 15**  
Input bias current – Ambient temperature  
( $V_{icm}=0[V]$ ,  $V_{OUT}=1.4[V]$ )

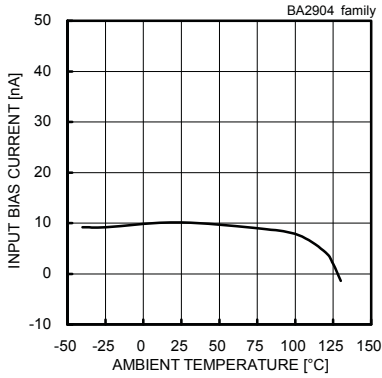

**Fig. 16**  
Input bias current – Ambient temperature  
( $V_{CC}=30[V]$ ,  $V_{icm}=28[V]$ ,  $V_{OUT}=1.4[V]$ )

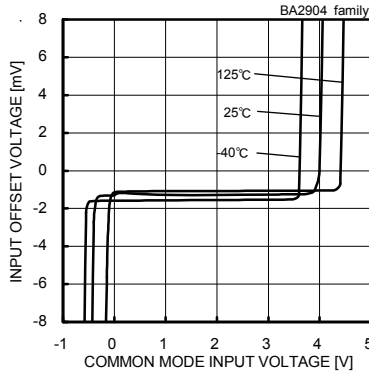

**Fig. 17**  
Input offset voltage – common-mode input voltage  
( $V_{CC}=5[V]$ )

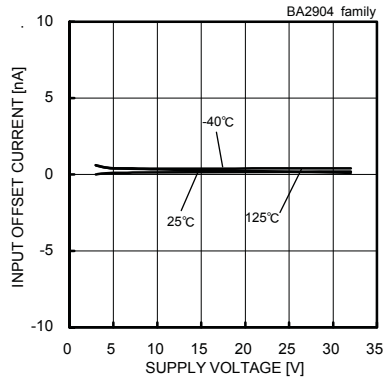

**Fig. 18**  
Input offset current – Supply voltage  
( $V_{icm}=0[V]$ ,  $V_{OUT}=1.4[V]$ )

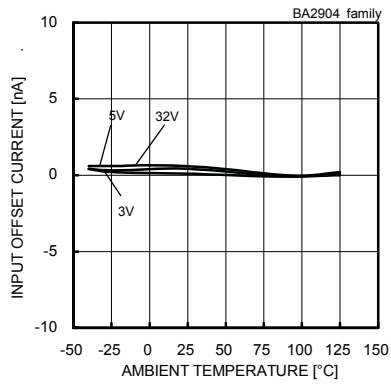

**Fig. 19**  
Input offset current – Ambient temperature  
( $V_{icm}=0[V]$ ,  $V_{OUT}=1.4[V]$ )

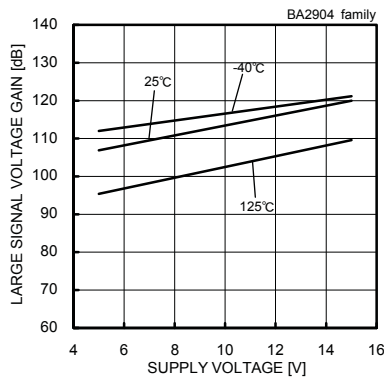

**Fig. 20**  
Large signal voltage gain – Supply voltage  
( $R_L=2[k\Omega]$ )

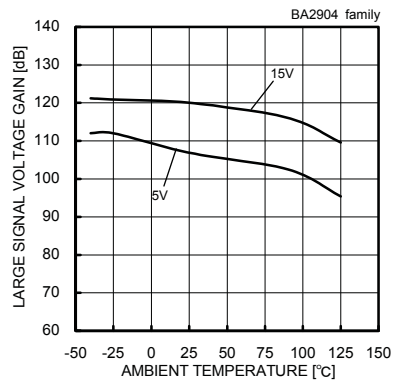

**Fig. 21**  
Large signal voltage gain – Ambient temperature  
( $R_L=2[k\Omega]$ )

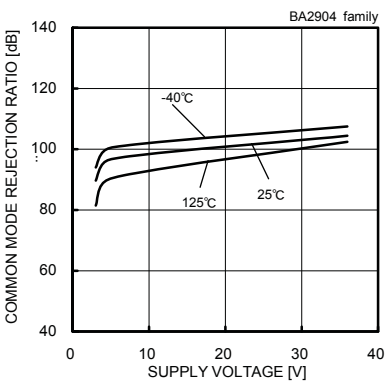

**Fig. 22**  
Common - mode rejection ratio – Supply voltage

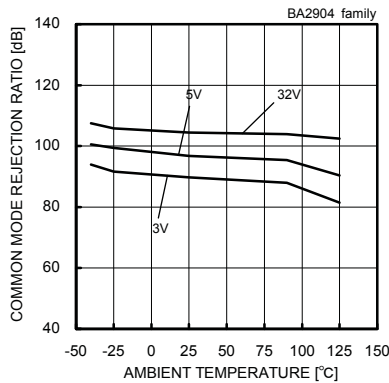

**Fig. 23**  
Common - mode rejection ratio - Ambient temperature

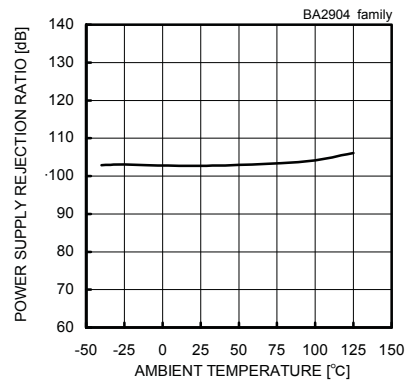

**Fig. 24**  
Power supply rejection ratio - Ambient temperature

(\*) The above data is ability value of sample, it is not guaranteed.

● BA2902 family

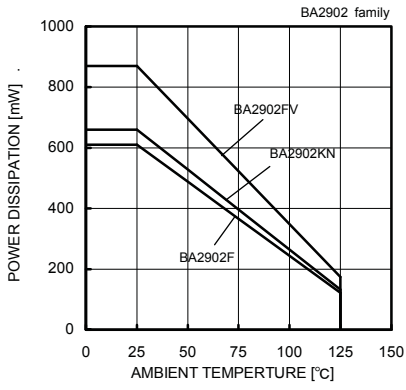

Fig.1  
Derating curve

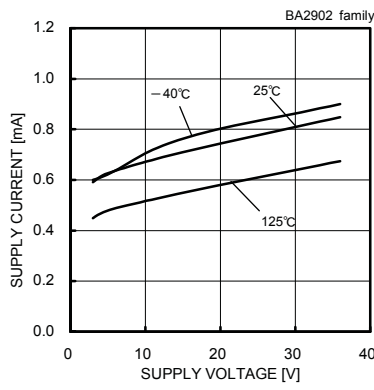

Fig.2  
Supply current - Supply voltage

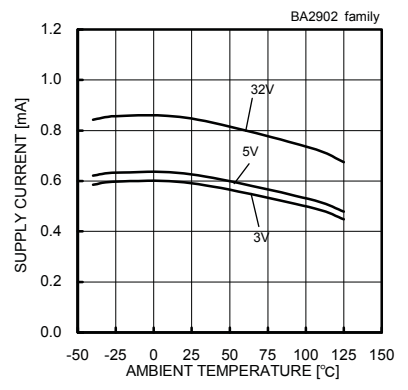

Fig.3  
Supply current - Ambient temperature

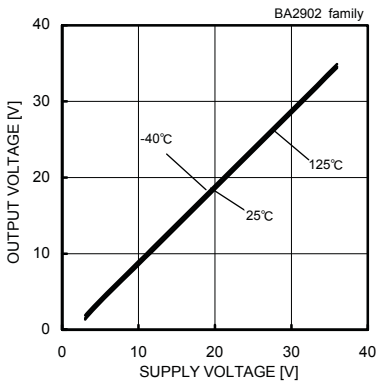

Fig.4  
Output voltage - Supply voltage  
( $R_L=10[k\Omega]$ )

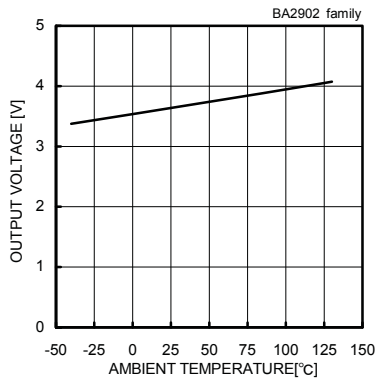

Fig.5  
Output voltage - Ambient temperature  
( $V_{CC}=5[V]$ ,  $R_L=2[k\Omega]$ )

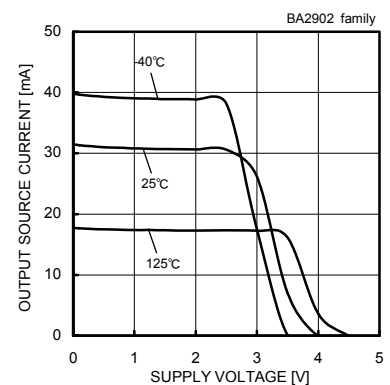

Fig.6  
Output source current - Output voltage  
( $V_{CC}=5[V]$ )

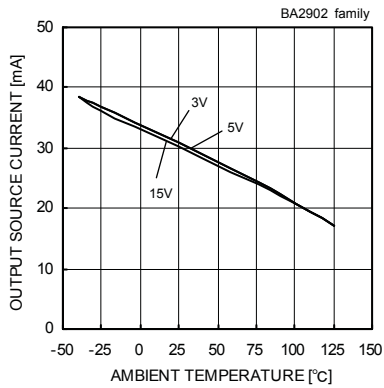

Fig.7  
Output source current - Ambient temperature  
( $V_{OUT}=0[V]$ )

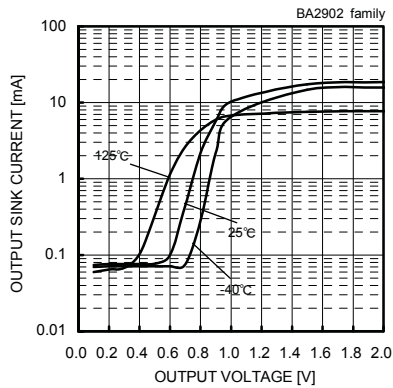

Fig.8  
Output sink current - Output voltage  
( $V_{CC}=5[V]$ )

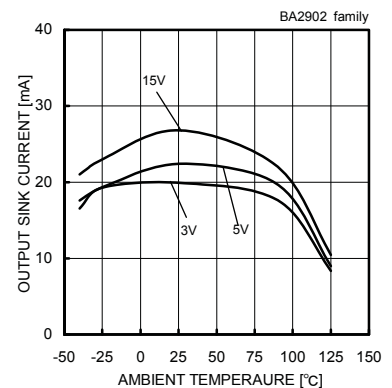

Fig.9  
Output sink current - Ambient temperature  
( $V_{OUT}=V_{CC}$ )

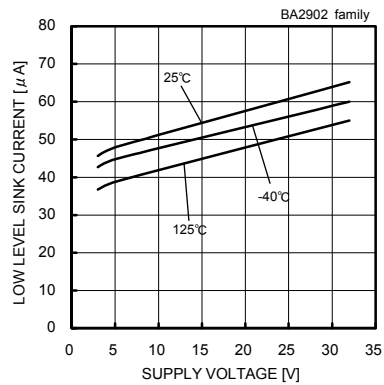

Fig.10  
Low level sink current - Supply voltage  
( $V_{OUT}=0.2[V]$ )

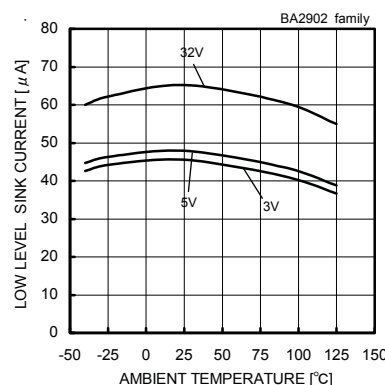

Fig.11  
Low level sink current - Ambient temperature  
( $V_{OUT}=0.2[V]$ )

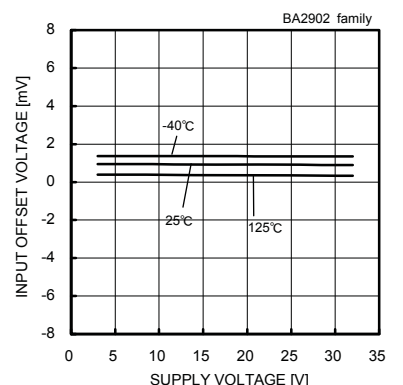
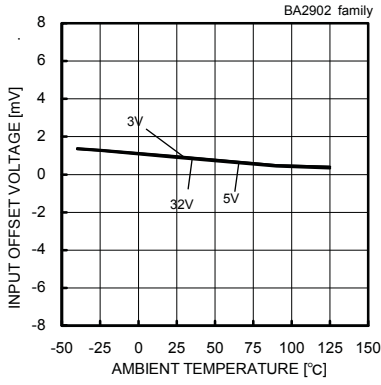

Fig.12  
Input offset voltage - Supply voltage  
( $V_{ICM}=0[V]$ ,  $V_{OUT}=1.4[V]$ )

(\*) The above data is ability value of sample, it is not guaranteed.

● BA2902 family



**Fig. 13**  
Input offset voltage – Ambient temperature  
( $V_{icm}=0[V]$ ,  $V_{OUT}=1.4[V]$ )

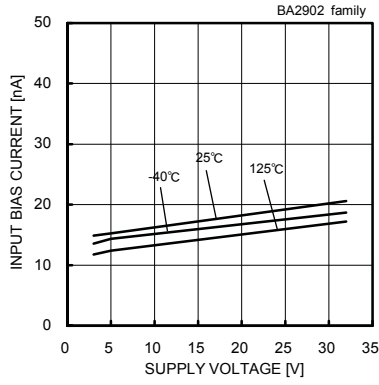

**Fig. 14**  
Input bias current – Supply voltage  
( $V_{icm}=0[V]$ ,  $V_{OUT}=1.4[V]$ )

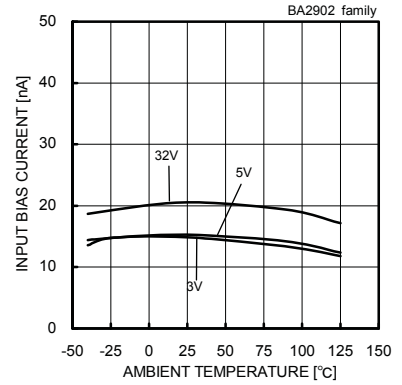

**Fig. 15**  
Input bias current – Ambient temperature  
( $V_{icm}=0[V]$ ,  $V_{OUT}=1.4[V]$ )

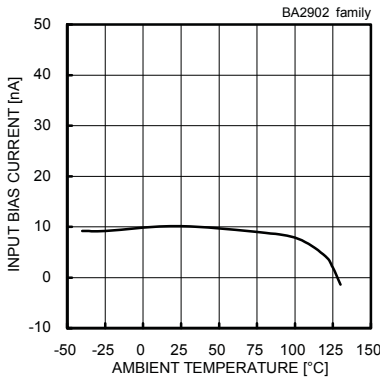

**Fig. 16**  
Input bias current – Ambient temperature  
( $V_{CC}=30[V]$ ,  $V_{icm}=28[V]$ ,  $V_{OUT}=1.4[V]$ )

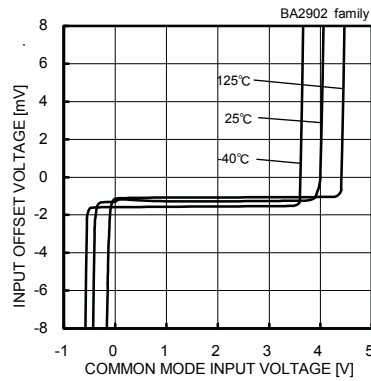

**Fig. 17**  
Input offset voltage – Common-mode input voltage  
( $V_{CC}=5[V]$ )

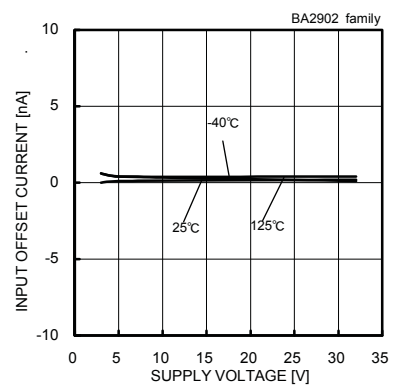

**Fig. 18**  
Input offset current – Supply voltage  
( $V_{icm}=0[V]$ ,  $V_{OUT}=1.4[V]$ )

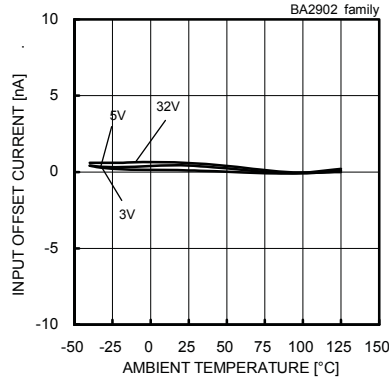

**Fig. 19**  
Input offset current – Ambient temperature  
( $V_{icm}=0[V]$ ,  $V_{OUT}=1.4[V]$ )

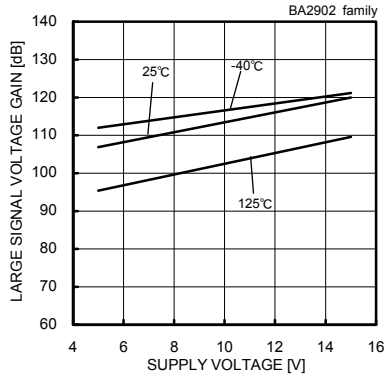

**Fig. 20**  
Large signal voltage gain – Supply voltage  
( $R_L=2[k\Omega]$ )

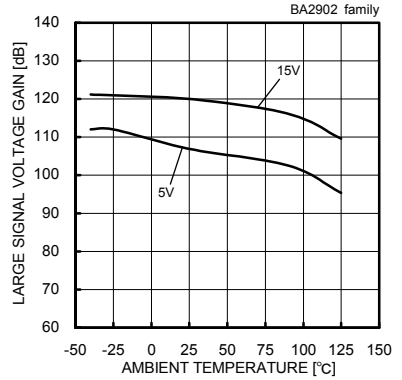

**Fig. 21**  
Large signal voltage gain – Ambient temperature  
( $R_L=2[k\Omega]$ )

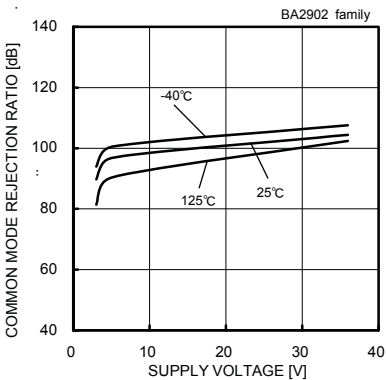

**Fig. 22**  
Common - mode rejection ratio – Supply voltage

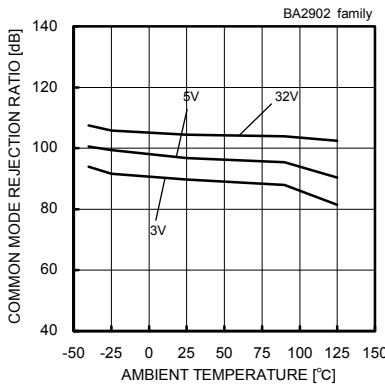

**Fig. 23**  
Common - mode rejection ratio - Ambient temperature

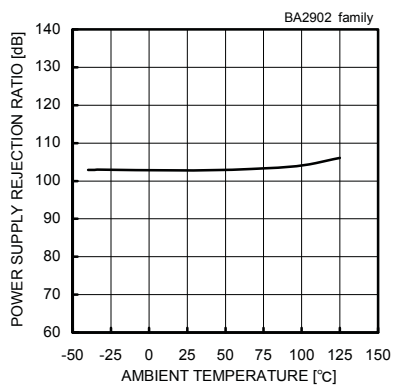

**Fig. 24**  
Power supply rejection ratio - Ambient temperature

(\*) The above data is ability value of sample, it is not guaranteed.

● BA3404 family

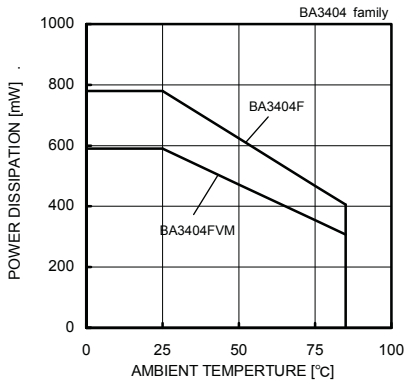

Fig.1  
Derating curve

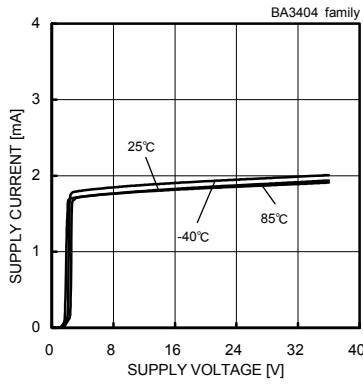

Fig.2  
Supply current - Supply voltage

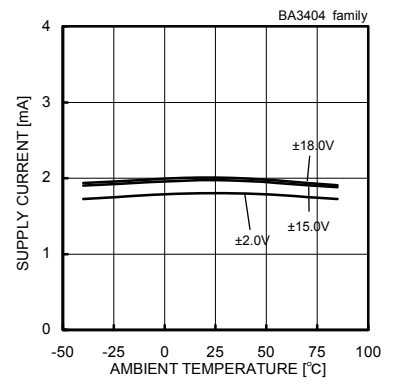

Fig.3  
Supply current - Ambient temperature

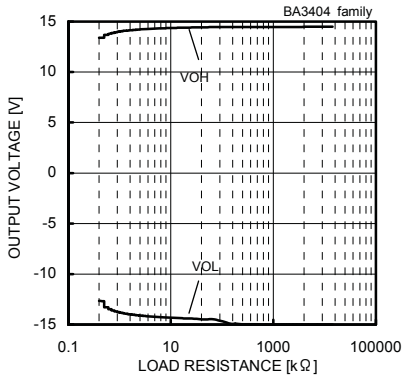

Fig.4  
Output voltage - Load resistance  
(VCC/VEE=+15[V]/-15[V], Ta=25[°C])

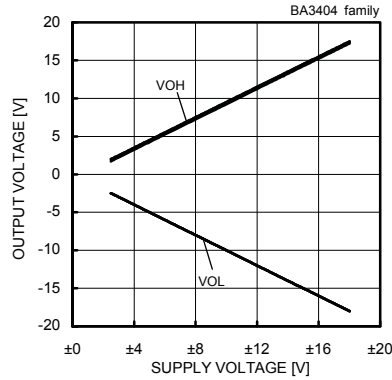

Fig.5  
Output voltage - Supply voltage

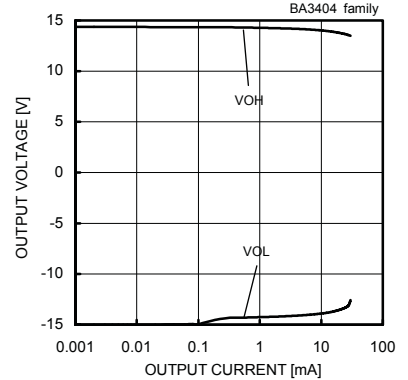

Fig.6  
Output voltage - Output current  
(VCC/VEE=+15[V]/-15[V], Ta=25[°C])

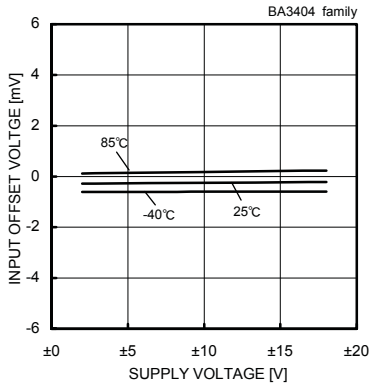

Fig.7  
Input offset voltage - Supply voltage  
(Vicm=0[V], VOUT=0[V])

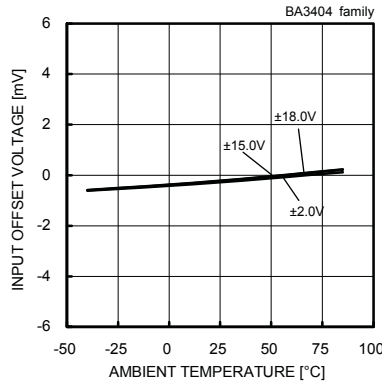

Fig.8  
Input offset voltage - Ambient temperature  
(Vicm=0[V], VOUT=0[V])

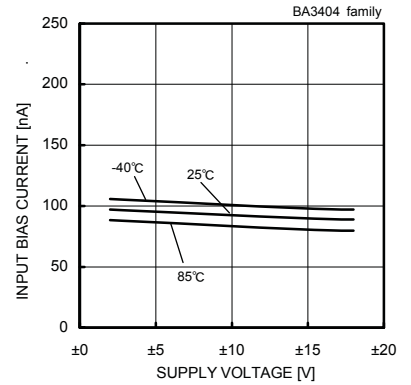

Fig.9  
Input bias current - Supply voltage  
(Vicm=0[V], VOUT=0[V])

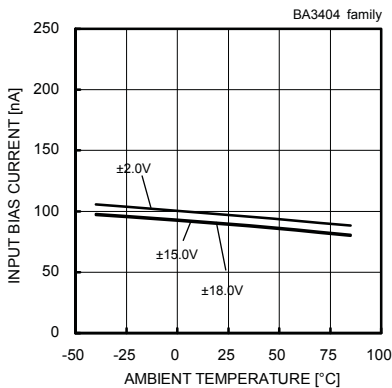

Fig.10  
Input bias current - Ambient temperature  
(Vicm=0[V], VOUT=0[V])

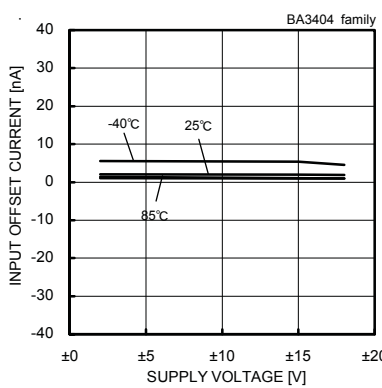

Fig.11  
Input offset current - Supply voltage  
(Vicm=0[V], VOUT=0[V])

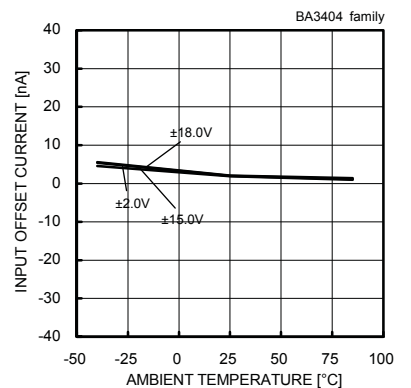
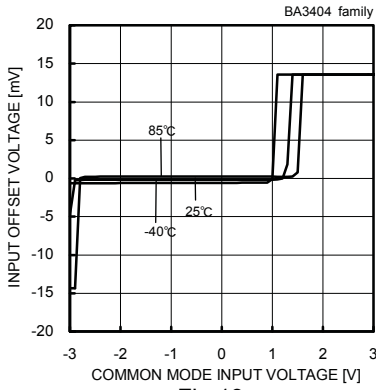

Fig.12  
Input offset current - Ambient temperature  
(Vicm=0[V], VOUT=0[V])

(\*) The above data is ability value of sample, it is not guaranteed.

● BA3404 family



**Fig. 13**  
Input offset voltage  
– Common-mode input voltage  
(VCC/VEE=+2.5[V]/-2.5[V])

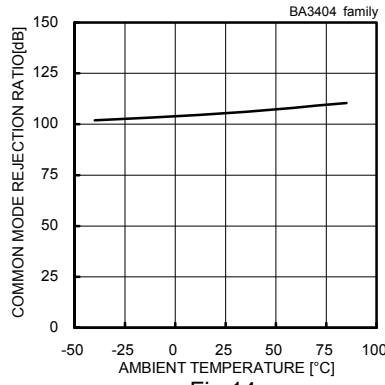

**Fig. 14**  
Common-mode rejection ratio  
– Ambient temperature  
(VCC/VEE=+15[V]/-15[V])

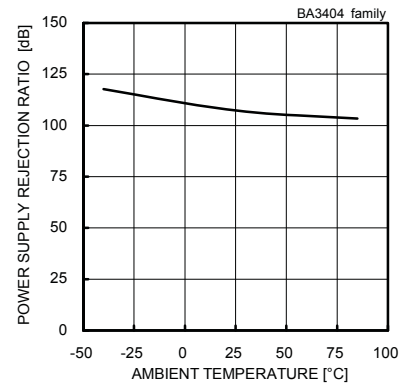

**Fig. 15**  
Power supply rejection ratio  
– Ambient temperature  
(VCC/VEE=+15[V]/-15[V])

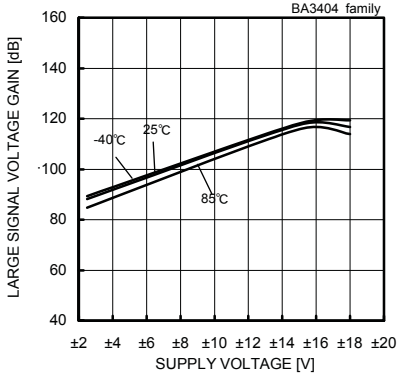

**Fig. 16**  
Large signal voltage gain – Supply voltage  
(RL=2[kΩ])

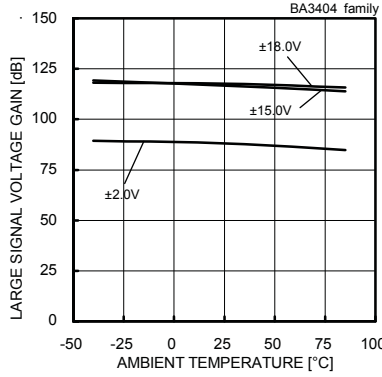

**Fig. 17**  
Large signal voltage gain – Ambient temperature  
(RL=2[kΩ])

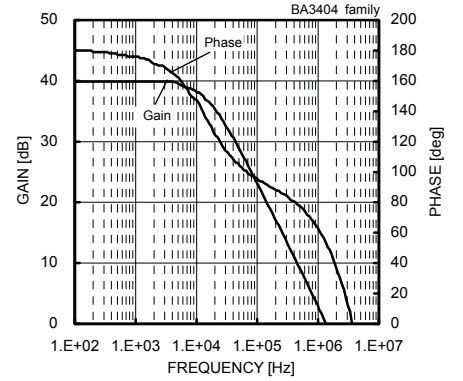

**Fig. 18**  
Gain - Frequency  
(VCC=±15V)

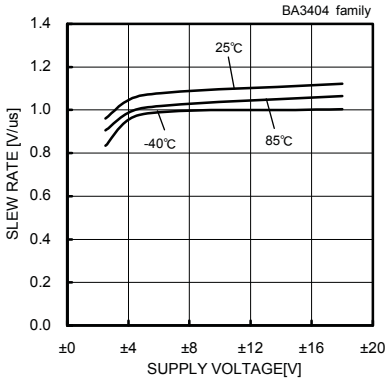

**Fig. 19**  
Slew rate – Supply voltage

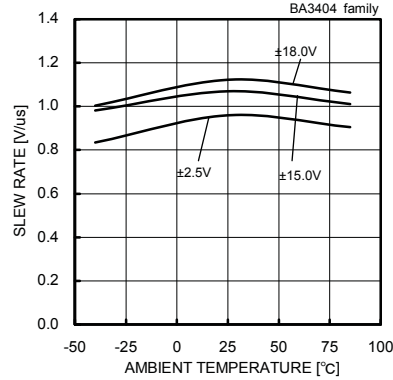

**Fig. 20**  
Slew rate – Ambient temperature

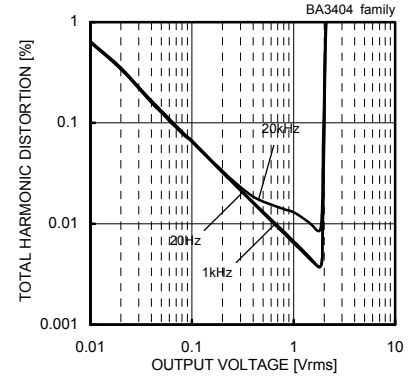

**Fig. 21**  
Total harmonic distortion – Output voltage  
(VCC/VEE=+4[V]/-4[V], Av=0[dB],  
RL=2[kΩ], 80[kHz]-LPF, Ta=25[°C])

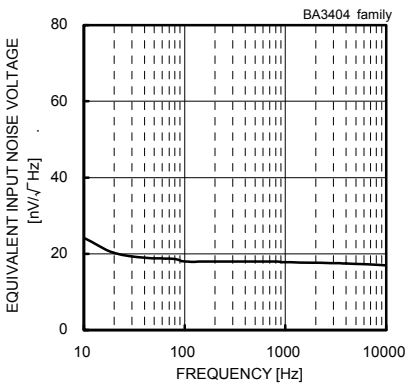

**Fig. 22**  
Equivalent input noise voltage - Frequency  
(VCC/VEE=+15[V]/-15[V], Rs=100[Ω], Ta=25[°C])

(\*) The above data is ability value of sample, it is not guaranteed.

● Schematic diagram

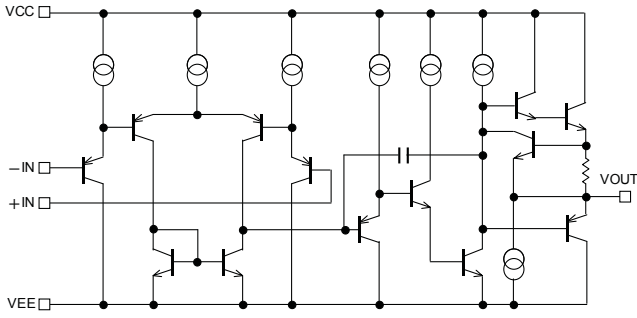

BA10358/BA10324A/BA2904/BA2902 simplified schematic

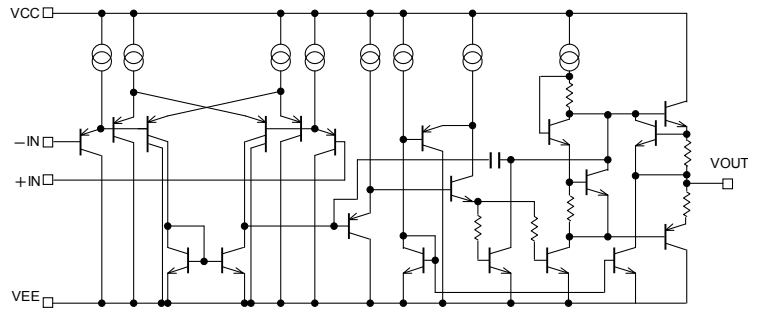

BA3404 simplified schematic

Fig1. Simplified schematic (each Op-Amp)

● Test circuit1 NULL method

VCC,VEE,EK,Vicm,Unit :[V]

Parameter	VF	S1	S2	S3	BA10358/BA10324 family				BA2904/BA2902 family				BA3404 family				Calculation
					Vcc	VEE	EK	Vicm	Vcc	VEE	EK	Vicm	VCC	VEE	EK	Vicm	
Input offset voltage	VF1	ON	ON	OFF	5	0	-1.4	0	5~30	0	-1.4	0	15	-15	0	0	1
Input offset current	VF2	OFF	OFF	OFF	5	0	-1.4	0	5	0	-1.4	0	15	-15	0	0	2
Input bias current	VF3	OFF	ON	OFF	5	0	-1.4	0	5	0	-1.4	0	15	-15	0	0	3
	VF4	ON	OFF														
Large signal voltage gain	VF5	ON	ON	ON	15	0	-1.4	0	15	0	-1.4	0	15	-15	10	0	4
	VF6				15	0	-11.4	0	15	0	-11.4	0	15	-15	-10	0	
Common-mode rejection ratio (Input common-mode voltage range)	VF7	ON	ON	OFF	5	0	-1.4	0	5	0	-1.4	0	15	-15	0	-15	5
	VF8				5	0	-1.4	3.5	5	0	-1.4	3.5	15	-15	0	13	
Power supply rejection ratio	VF9	ON	ON	OFF	5	0	-1.4	0	5	0	-1.4	0	2	-2	0	0	6
	VF10				30	0	-1.4	0	30	0	-1.4	0	15	-15	0	0	

—Calculation—

1. Input offset Voltage (Vio)

$$V_{io} = \frac{|VF1|}{1 + R_f / R_s} \text{ [V]}$$

2. Input offset current (Iio)

$$I_{io} = \frac{|VF2 - VF1|}{R_i \times (1 + R_f / R_s)} \text{ [A]}$$

3. Input bias current (Ib)

$$I_b = \frac{|VF4 - VF3|}{2 \times R_i \times (1 + R_f / R_s)} \text{ [A]}$$

4. Large signal voltage gain (Av)

$$A_v = 20 \times \text{Log} \frac{\Delta E_K \times (1 + R_f / R_s)}{|VF5 - VF6|} \text{ [dB]}$$

5. Common-mode rejection ratio (CMRR)

$$\text{CMRR} = 20 \times \text{Log} \frac{\Delta V_{icm} \times (1 + R_f / R_s)}{|VF8 - VF7|} \text{ [dB]}$$

6. Power supply rejection ratio (PSRR)

$$\text{PSRR} = 20 \times \text{Log} \frac{\Delta V_{cc} \times (1 + R_f / R_s)}{|VF10 - VF9|} \text{ [dB]}$$

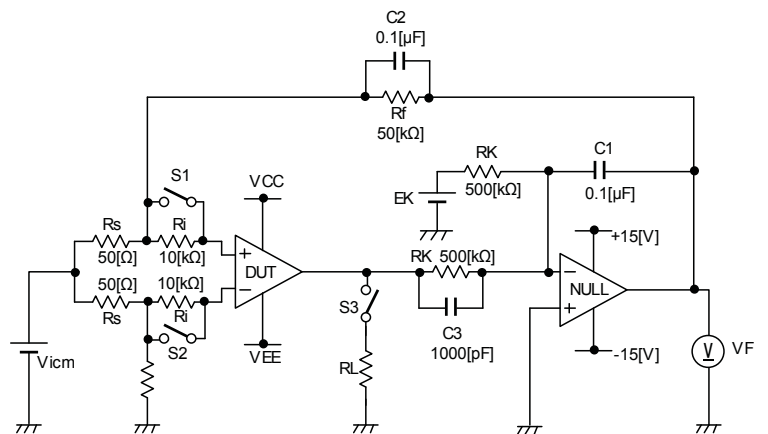

Fig2. Test circuit 1 (each Op-Amp)

● Test circuit2 switch condition

Unit: [V]

SW No.	SW 1	SW 2	SW 3	SW 4	SW 5	SW 6	SW 7	SW 8	SW 9	SW 10	SW 11	SW 12	SW 13	SW 14
Supply current	OFF	OFF	OFF	ON	OFF	ON	OFF	OFF	OFF	OFF	OFF	OFF	OFF	OFF
High level output voltage	OFF	OFF	ON	OFF	OFF	ON	OFF	OFF	OFF	ON	OFF	OFF	OFF	ON
Low level output voltage	OFF	OFF	ON	OFF	OFF	ON	OFF	OFF	OFF	OFF	OFF	OFF	ON	OFF
Output source current	OFF	OFF	ON	OFF	OFF	ON	OFF	OFF	OFF	OFF	OFF	OFF	OFF	ON
Output sink current	OFF	OFF	ON	OFF	OFF	ON	OFF	OFF	OFF	OFF	OFF	OFF	OFF	ON
Slew rate	OFF	OFF	OFF	ON	OFF	OFF	OFF	ON	ON	ON	OFF	OFF	OFF	OFF
Gain bandwidth product	OFF	ON	OFF	OFF	ON	ON	OFF	OFF	ON	ON	OFF	OFF	OFF	OFF
Input noise voltage	ON	OFF	OFF	OFF	ON	ON	OFF	OFF	OFF	OFF	ON	OFF	OFF	OFF

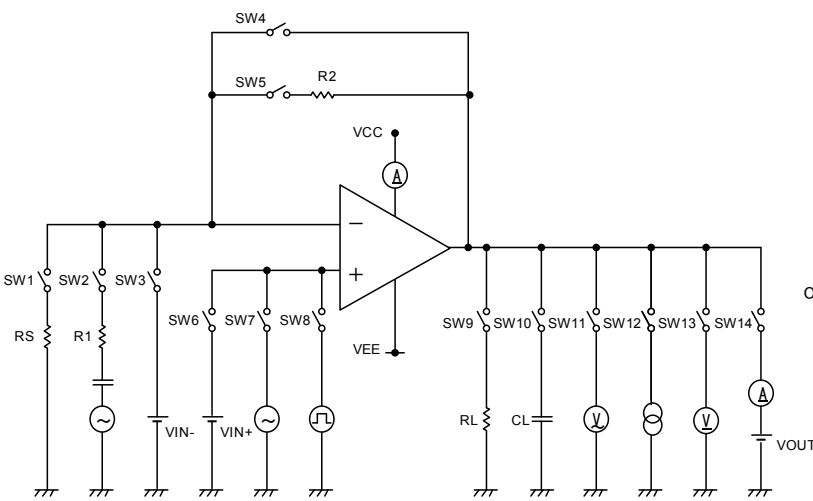

Fig3. Test circuit2 (each Op-Amp)

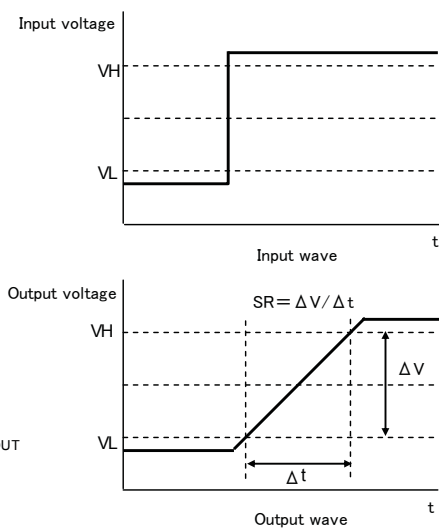

Fig4. Slew rate input output wave

● Test circuit3 Channel separation

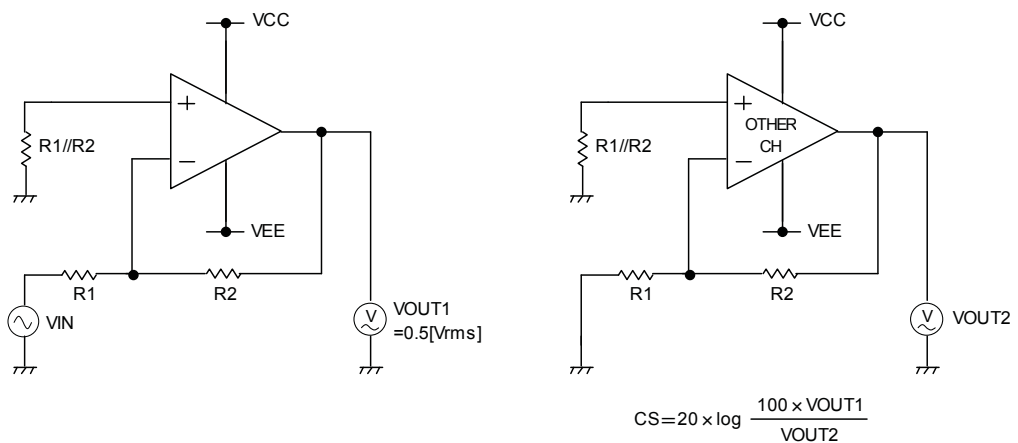

Fig5. Test circuit3



## ● Description of electrical characteristics

Described here are the terms of electric characteristics used in this technical note. Items and symbols used are also shown.

Note that item name and symbol and their meaning may differ from those on another manufacture's document or general document.

### 1. Absolute maximum ratings

Absolute maximum rating item indicates the condition which must not be exceeded. Application of voltage in excess of absolute maximum rating or use of absolute maximum rated temperature environment may cause deterioration of characteristics.

- 1.1 Power supply voltage (VCC—VEE)  
Indicates the maximum voltage that can be applied between the positive power supply terminal and negative power supply terminal without deterioration or destruction of characteristics of internal circuit.
- 1.2 Differential input voltage (Vid)  
Indicates the maximum voltage that can be applied between non-inverting terminal and inverting terminal without deterioration and destruction of characteristics of IC.
- 1.3 Input common-mode voltage range (Vicm)  
Indicates the maximum voltage that can be applied to non-inverting terminal and inverting terminal without deterioration or destruction of characteristics. Input common-mode voltage range of the maximum ratings not assure normal operation of IC. When normal operation of IC is desired, the input common-mode voltage of characteristics item must be followed.
- 1.4 Operating temperature range and storage temperature range (Topr, Tstg)  
Operating temperature range indicates the temperature range where IC can operate. The higher the ambient temperature becomes, the lower is the power consumed by IC. Storage temperature range where IC can be stored without excessive deterioration of characteristics of IC.
- 1.5 Power dissipation (Pd)  
Indicates the power that can be consumed by specified mounted board at the ambient temperature 25°C(normal temperature). As for package product, Pd is determined by the temperature that can be permitted by IC chip in the package (maximum junction temperature) and thermal resistance of the package

### 2. Electrical characteristics item

- 2.1 Input offset voltage (Vio)  
Indicates the voltage difference between non-inverting terminal and inverting terminal. It can be translated into the input voltage difference required for setting the output voltage at 0 [V]
- 2.2 Input offset voltage drift ( $\Delta V_{io}/\Delta T$ )  
Indicates the ratio of input offset voltage fluctuation against ambient temperature fluctuation.
- 2.3 Input offset current (Iio)  
Indicates the difference of input bias current between non-inverting terminal and inverting terminal.
- 2.4 Input offset current drift ( $\Delta I_{io}/\Delta T$ )  
Indicates the difference of input bias current between non-inverting terminal and inverting terminal.
- 2.5 Input bias current (Ib)  
Indicates the current that flows into or out of the input terminal. It is defined by the average of input bias current at non-inverting terminal and input bias current at inverting terminal.
- 2.6 Circuit current (ICC)  
Indicates the IC current that flows under specified conditions and no-load steady status.
- 2.7 High level output voltage / Low level output voltage (VOH/VOL)  
Indicates the voltage range that can be output by the IC under specified load condition. It is typically divided into high-level output voltage and low-level output voltage. High-level output voltage indicates the upper limit of output voltage. Low-level output voltage indicates the lower limit.
- 2.8 Large signal voltage gain (AV)  
Indicates the amplifying rate (gain) of output voltage against the voltage difference between non-inverting terminal and inverting terminal. It is normally the amplifying rate (gain) with reference to DC voltage.  
$$A_v = (\text{Output voltage fluctuation}) / (\text{Input offset fluctuation})$$
- 2.9 Input common-mode voltage range (Vicm)  
Indicates the input voltage range where IC operates normally.
- 2.10 Common-mode rejection ratio (CMRR)  
Indicates the ratio of fluctuation of input offset voltage when in-phase input voltage is changed. It is normally the fluctuation of DC.  
$$CMRR = (\text{Change of Input common-mode voltage}) / (\text{Input offset fluctuation})$$
- 2.11 Power supply rejection ratio (PSRR)  
Indicates the ratio of fluctuation of input offset voltage when supply voltage is changed. It is normally the fluctuation of DC.  
$$PSRR = (\text{Change of power supply voltage}) / (\text{Input offset fluctuation})$$
- 2.12 Output source current / Output sink current (IOH/IOL)  
Indicates the maximum current that can be output under specified output condition (such as output voltage and load condition). It is divided into output source current and output sink current. Output source current indicates the current flowing out of IC, and output sink current flowing into IC.
- 2.13 Channel separation (CS)  
Indicates the fluctuation of input offset voltage or that of output voltage with reference to the change of output voltage of driven channel.
- 2.14 Slew rate (SR)  
Indicates the time fluctuation ratio of voltage output when step input signal is applied
- 2.15 Gain band width product (GBW)  
Indicates the product of specified signal frequency and the gain of Op Amp at such frequency. it gives the approximate value of frequency where the gain of Op Amp is 1(maximum frequency, and unity gain frequency).

● Derating curve

Power dissipation (total loss) indicates the power that can be consumed by IC at Ta=25°C(normal temperature). IC is heated when it consumed power, and the temperature of IC chip becomes higher than ambient temperature. The temperature that can be accepted by IC chip depends on circuit configuration, manufacturing process, and consumable power is limited. Power dissipation is determined by the temperature allowed in IC chip (maximum junction temperature) and thermal resistance of package (heat dissipation capability). The maximum junction temperature is typically equal to the maximum value in the storage temperature range. Heat generated by consumed power of IC radiates from the mold resin or lead frame of the package. The parameter which indicates this heat dissipation capability (hardness of heat release) is called thermal resistance, represented by the symbol  $\theta_{ja}$ [°C/W]. The temperature of IC inside the package can be estimated by this thermal resistance. Fig.6 (a) shows the model of thermal resistance of the package. Thermal resistance  $\theta_{ja}$ , ambient temperature Ta, junction temperature Tj, and power dissipation Pd can be calculated by the equation below :

$$\theta_{ja} = (T_j - T_a) / P_d \quad [^{\circ}\text{C}/\text{W}] \quad \dots \dots (1)$$

Derating curve in Fig.6 (b) indicates power that can be consumed by IC with reference to ambient temperature. Power that can be consumed by IC begins to attenuate at certain ambient temperature. This gradient, is determined by thermal resistance  $\theta_{ja}$ . Thermal resistance  $\theta_{ja}$  depends on chip size, power consumption, package, ambient temperature, package condition, wind velocity, etc even when the same of package is used. Thermal reduction curve indicates a reference value measured at a specified condition. Fig.7(a)-(d) show a derating curve for an example of BA10358, BA10324A, BA2904, and BA2902.

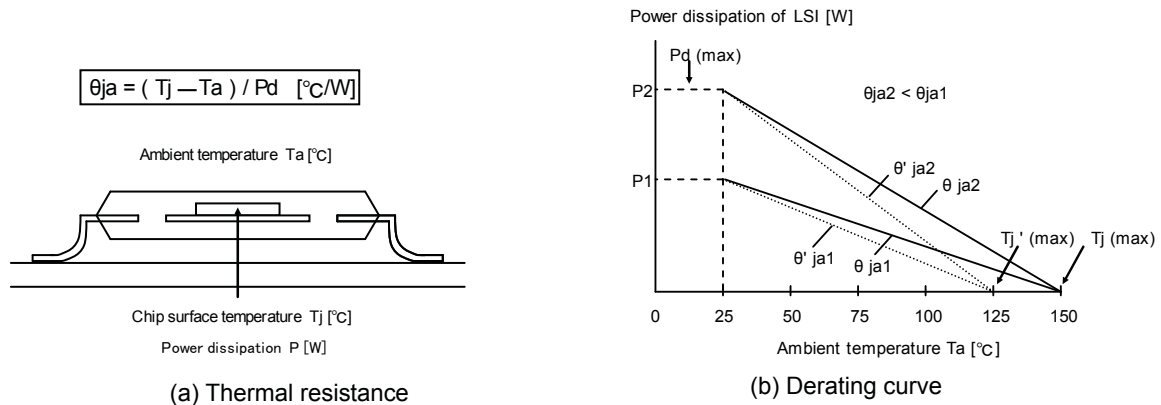
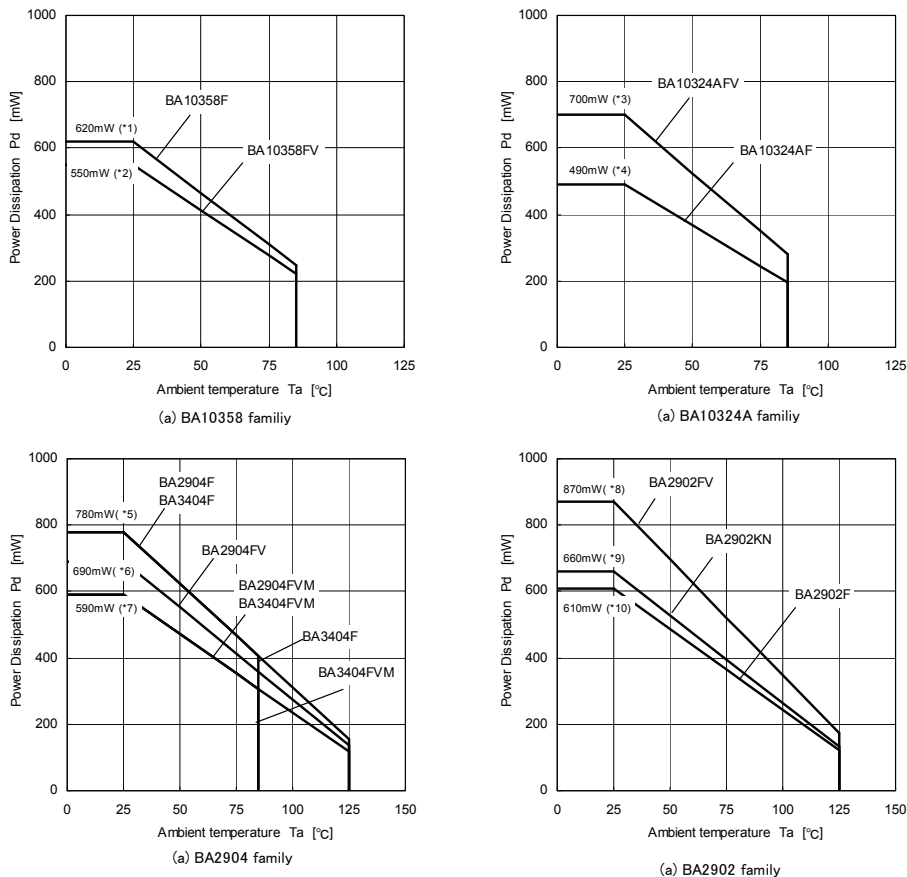

Fig1. Thermal resistance and derating curve



(*1)	(*2)	(*3)	(*4)	(*5)	(*6)	(*7)	(*8)	(*9)	(*10)	Unit
6.2	5.5	7.0	4.9	6.2	5.5	4.8	7.0	5.3	4.9	[mW/°C]

When using the unit above Ta=25[°C], subtract the value above per degree[°C]. Permissible dissipation is the value when FR4 glass epoxy board 70[mm]×70[mm]×1.6[mm] (cooper foil area below 3[%]) is mounted.

Fig2. Derating curve

## ● Cautions on use

### 1) Processing of unused circuit

It is recommended to apply connection (see the Fig.9) and set the noninverting input terminal at the potential within input common-mode voltage range ( $V_{icm}$ ), for any unused circuit.

### 2) Input voltage

Applying  $V_{EE}+32[V]$ (BA2904/BA2902 family) and  $V_{EE}+36[V]$ (BA3404 family) to the input terminal is possible without causing deterioration of the electrical characteristics or destruction, irrespective of the supply voltage.

However, this does not ensure normal circuit operation.

Please note that the circuit operates normally only when the input voltage is within the common mode input voltage range of the electric characteristics.

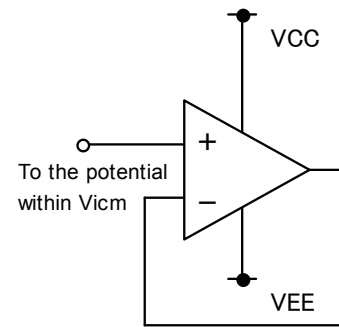

Fig.1 Example of processing unused circuit

### 3) Power supply (split supply / single supply) in used

Op amp operates when specified voltage is applied between  $V_{CC}$  and  $V_{EE}$ . Therefore, the single supply Op Amp can be used for split supply Op Amp as well.

### 4) Power dissipation ( $P_d$ )

Use a thermal design that allows for a sufficient margin in light of the power dissipation ( $P_d$ ) in actual operating conditions.

### 5) Short-circuit between pins and wrong mounting

Pay attention to the assembly direction of the ICs. Wrong mounting direction or shorts between terminals, GND, or other components on the circuits, can damage the IC.

### 6) Use in strong electromagnetic field

Using the ICs in strong electromagnetic field can cause operation malfunction.

### 7) Radiation

This IC is not designed to be radiation-resistant.

### 8) Handling of IC

When stress is applied to IC because of deflection or bend of board, the characteristics may fluctuate due to piezoelectric (piezo) effect.

### 9) Output stage operation

The output stage of the IC is configured using class C push-pull circuits. Therefore, when the load resistor is connect to the middle potential of  $V_{CC}$  and  $V_{EE}$ , crossover distortion occurs at the change over between discharging and charging of output current. Connecting a resistor between the output terminal and  $V_{EE}$ , and increasing the bias current for class A operation will suppress cross over distortion.

### 10) Inspection on set board

During testing, turn on or off the power before mounting or dismantling the board from the test Jig.

Do not power up the board without waiting for the output capacitors to discharge. The capacitors in the low output impedance terminal can stress the device. Pay attention to the electro static voltages during IC handling, transportation, and storage.

### 11) Output capacitor

When  $V_{CC}$  terminal is shorted to  $V_{EE}$  (GND) potential and an electric charge has accumulated on the external capacitor, connected to output terminal, accumulated charge may be discharged  $V_{CC}$  terminal via the parasitic element within the circuit or terminal protection element. The element in the circuit may be damaged (thermal destruction). When using this IC for an application circuit where there is oscillation, output capacitor load does not occur, as when using this IC as a voltage comparator. Set the capacitor connected to output terminal below  $0.1[\mu F]$  in order to prevent damage to IC.

● Dimensions

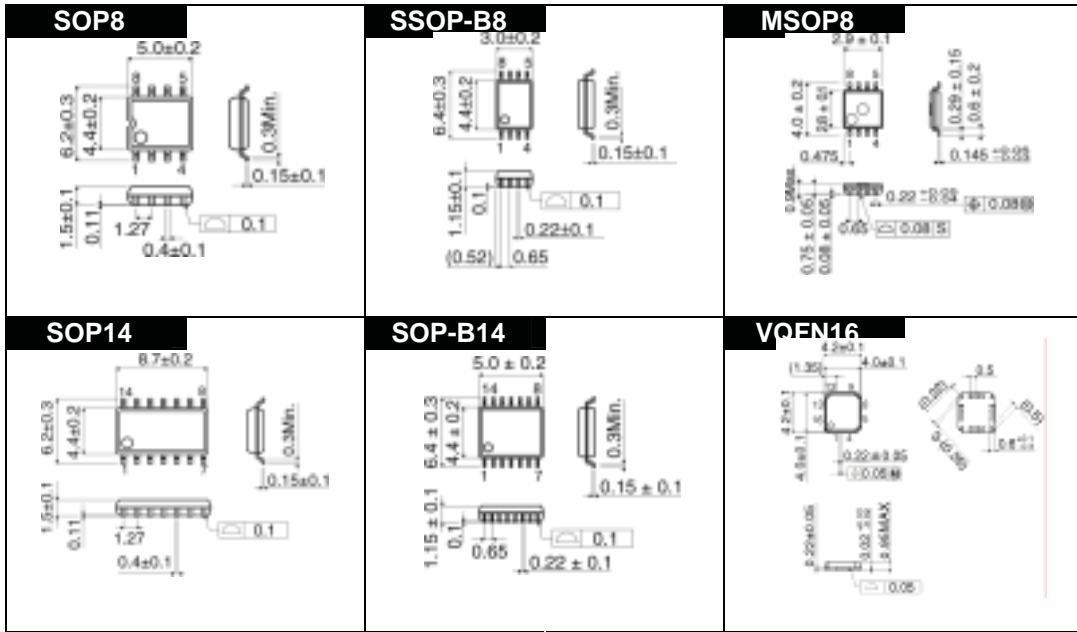

● Model number construction

- Specify the product by the model number when placing an order.
- Make sure of the combinations of items.
- Start with the leftmost space without leaving any empty space between characters.



- ROHM product name**
- BA10358
  - BA10324A
  - BA2904
  - BA2902
  - BA3404
- Package type**
- F : SOP8/SOP14
  - FV : SSOP-B8/SSOP-B14
  - FVM : MSOP8
  - KN : VQFN16
- E2 Embossed tape on reel with pin 1 near far when pulled out  
 TR Embossed tape on reel with pin 1 near far when pulled out

Packing specification reference

Package	Packing specification name	Quantity	Embossed carrier tape
SOP8/ SSOP-B8/ SOP14/ SSOP-B14	E2	2500	
MSOP8	TR	3000	
VQFN16	E2	2500	

### Notes

- No technical content pages of this document may be reproduced in any form or transmitted by any means without prior permission of ROHM CO.,LTD.
- The contents described herein are subject to change without notice. The specifications for the product described in this document are for reference only. Upon actual use, therefore, please request that specifications to be separately delivered.
- Application circuit diagrams and circuit constants contained herein are shown as examples of standard use and operation. Please pay careful attention to the peripheral conditions when designing circuits and deciding upon circuit constants in the set.
- Any data, including, but not limited to application circuit diagrams information, described herein are intended only as illustrations of such devices and not as the specifications for such devices. ROHM CO.,LTD. disclaims any warranty that any use of such devices shall be free from infringement of any third party's intellectual property rights or other proprietary rights, and further, assumes no liability of whatsoever nature in the event of any such infringement, or arising from or connected with or related to the use of such devices.
- Upon the sale of any such devices, other than for buyer's right to use such devices itself, resell or otherwise dispose of the same, no express or implied right or license to practice or commercially exploit any intellectual property rights or other proprietary rights owned or controlled by
- ROHM CO., LTD. is granted to any such buyer.
- Products listed in this document are no antiradiation design.

The products listed in this document are designed to be used with ordinary electronic equipment or devices (such as audio visual equipment, office-automation equipment, communications devices, electrical appliances and electronic toys).

Should you intend to use these products with equipment or devices which require an extremely high level of reliability and the malfunction of which would directly endanger human life (such as medical instruments, transportation equipment, aerospace machinery, nuclear-reactor controllers, fuel controllers and other safety devices), please be sure to consult with our sales representative in advance.

It is our top priority to supply products with the utmost quality and reliability. However, there is always a chance of failure due to unexpected factors. Therefore, please take into account the derating characteristics and allow for sufficient safety features, such as extra margin, anti-flammability, and fail-safe measures when designing in order to prevent possible accidents that may result in bodily harm or fire caused by component failure. ROHM cannot be held responsible for any damages arising from the use of the products under conditions out of the range of the specifications or due to non-compliance with the NOTES specified in this catalog.

Thank you for your accessing to ROHM product informations.

More detail product informations and catalogs are available, please contact your nearest sales office.

**ROHM** Customer Support System

THE AMERICAS / EUROPE / ASIA / JAPAN

[www.rohm.com](http://www.rohm.com)

Contact us : [webmaster@rohm.co.jp](mailto:webmaster@rohm.co.jp)

## X-ON Electronics

Largest Supplier of Electrical and Electronic Components

*Click to view similar products for [Operational Amplifiers - Op Amps](#) category:*

*Click to view products by [ROHM](#) manufacturer:*

Other Similar products are found below :

[NCV33072ADR2G](#) [LM358SNG](#) [430227FB](#) [UPC824G2-A](#) [LT1678IS8](#) [042225DB](#) [058184EB](#) [UPC822G2-A](#) [UPC259G2-A](#) [UPC258G2-A](#)  
[NCV33202DMR2G](#) [NTE925](#) [AZV358MTR-G1](#) [AP4310AUMTR-AG1](#) [HA1630D02MMEL-E](#) [HA1630S01LPEL-E](#) [SCY33178DR2G](#)  
[NJU77806F3-TE1](#) [NCV5652MUTWG](#) [NCV20034DR2G](#) [LM324EDR2G](#) [LM2902EDR2G](#) [NTE7155](#) [NTE778S](#) [NTE871](#) [NTE924](#) [NTE937](#)  
[MCP6V17T-E/MNY](#) [MCP6V19-E/ST](#) [MXD8011HF](#) [MCP6V17T-E/MS](#) [SCY6358ADR2G](#) [ADA4523-1BCPZ](#) [LTC2065HUD#PBF](#)  
[ADA4523-1BCPZ-RL7](#) [NJM2904CRB1-TE1](#) [2SD965T-R](#) [RS6332PXK](#) [BDM8551](#) [BDM321](#) [MD1324](#) [COS8052SR](#) [COS8552SR](#)  
[COS8554SR](#) [COS2177SR](#) [COS2353SR](#) [COS724TR](#) [ASOPD4580S-R](#) [RS321BKXF](#) [ADA4097-1HUIZ-RL7](#)