

# Dual operational amplifier

## BA4558 / BA4558F / BA4558N

The BA4558, BA4558F, and BA4558N are monolithic ICs with two operational amplifiers featuring low power consumption and internal phase compensation mounted on a single silicon chip. These products offer high speed, a wide band width, and low noise.

Outstanding thermal characteristics and voltage gain band width make these ICs ideal for use in a wide variety of electronic circuits. The BA4558 comes in an 8-pin DIP package and is compatible with the 4558 operational amplifier. The BA4558F comes in an 8-pin SOP package, and the BA4558N in an 8-pin SIP package.

### ●Applications

- Active filters
- Audio amplifiers
- VCOs
- Other electronic circuits

### ●Features

- 1) Low power dissipation of approximately 50mW (typ.).
- 2) Built-in output short-circuit protection circuit.
- 3) Internal phase compensation.
- 4) No latch-up.
- 5) Wide range of common mode and differential voltage.
- 6) High gain and low noise.

### ●Block diagram

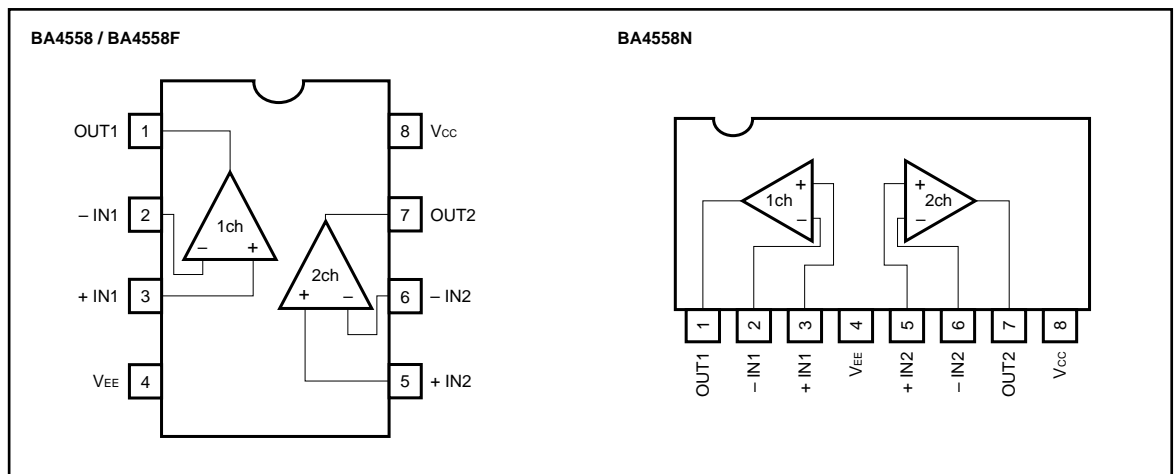

● Internal circuit configuration

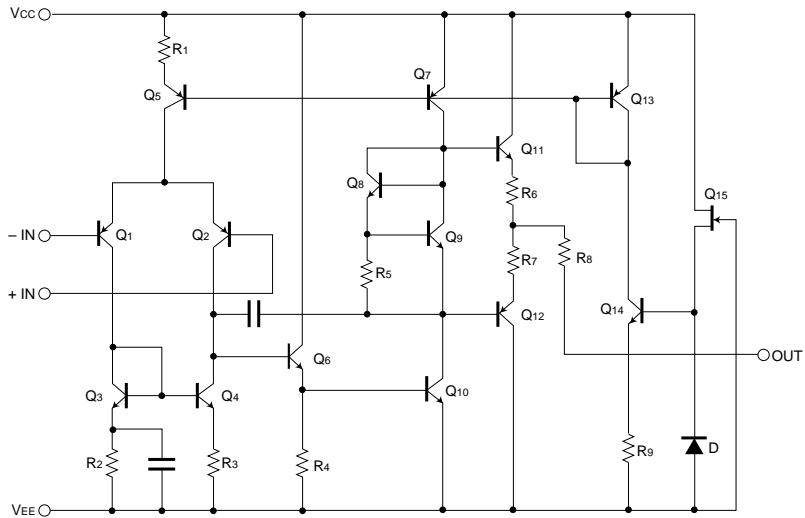

● Absolute maximum ratings (Ta = 25°C)

Parameter	Symbol	Limits			Unit
		BA4558	BA4558F	BA4558N	
Power supply voltage	V <sub>cc</sub>	± 18	± 18	± 18	V
Power dissipation	P <sub>d</sub>	800*	550*	900*	mW
Differential input voltage	V <sub>ID</sub>	± 30	± 30	± 30	V
Common-mode input voltage	V <sub>I</sub>	± 15	± 15	± 15	V
Operating temperature	T <sub>opr</sub>	- 40 ~ + 85	- 40 ~ + 85	- 40 ~ + 85	°C
Storage temperature	T <sub>stg</sub>	- 55 ~ + 125	- 55 ~ + 125	- 55 ~ + 125	°C

\* Refer to P<sub>d</sub> characteristics diagram.

The values for the BA4558F are those when it is mounted on a glass epoxy board ( 50mm × 50mm × 1.6mm ).

●Electrical characteristics (unless otherwise noted,  $T_a = 25^\circ\text{C}$ ,  $V_{CC} = +15\text{V}$ ,  $V_{EE} = -15\text{V}$ )

Parameter	Symbol	Min.	Typ.	Max.	Unit	Conditions
Input offset voltage	$V_{IO}$	—	0.5	6.0	mV	$R_s \leq 10\text{k}\Omega$
Input offset current	$I_{IO}$	—	5	200	nA	
Input bias current	$I_B$	—	60	500	nA	
High-amplitude voltage gain	$A_v$	86	100	—	dB	$R_L \cong 2\text{k}\Omega$ , $V_O = \pm 10\text{V}$
Common-mode input voltage	$V_{ICM}$	$\pm 12$	$\pm 14$	—	V	
Maximum output voltage	$V_{OH}$	$\pm 12$	$\pm 14$	—	V	$R_L \cong 10\text{k}\Omega$
Minimum output voltage	$V_{OL}$	$\pm 10$	$\pm 13$	—	V	$R_L \cong 2\text{k}\Omega$
Common-mode rejection ratio	CMRR	70	90	—	dB	$R_s \leq 10\text{k}\Omega$
Power supply voltage rejection ratio	PSRR	—	30	150	$\mu\text{V}/\text{V}$	$R_s \leq 10\text{k}\Omega$
Slew rate	S.R.	—	1.0	—	$\text{V}/\mu\text{s}$	$A_v = 1$ , $R_L \cong 2\text{k}\Omega$
Channel separation	CS	—	105	—	dB	$f = 1\text{kHz}$

●Electrical characteristic curves

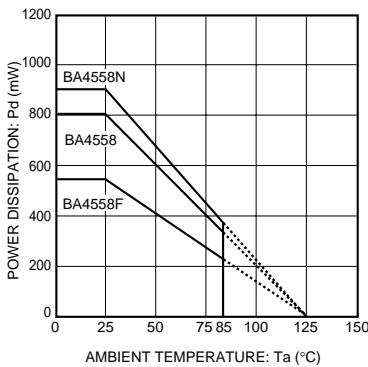

Fig.1 Power dissipation vs. ambient temperature

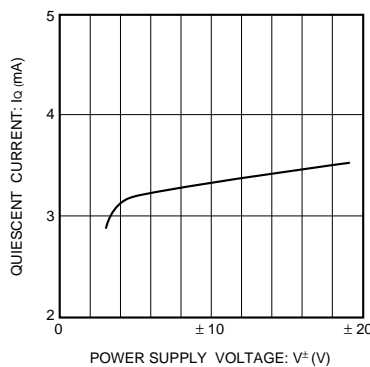

Fig.2 Quiescent current vs. power supply voltage

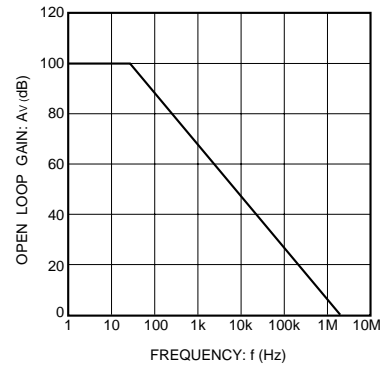

Fig.3 Open loop voltage gain vs. frequency

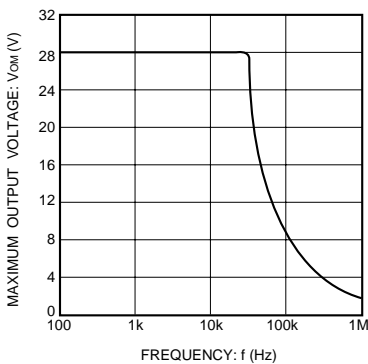

Fig.4 Maximum output voltage vs. frequency

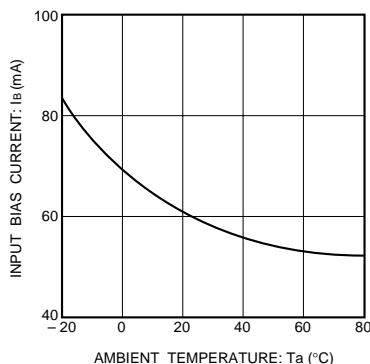

Fig.5 Input bias current vs. ambient temperature

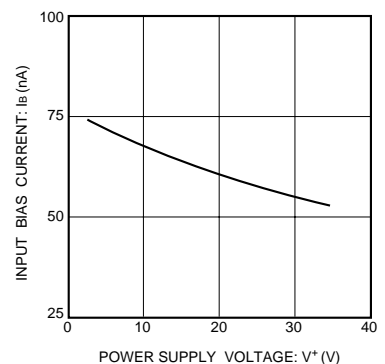

Fig.6 Input bias current vs. power supply voltage

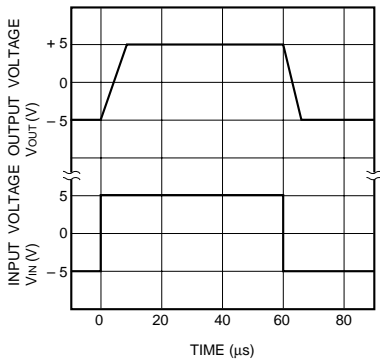

Fig.7 Output response characteristics

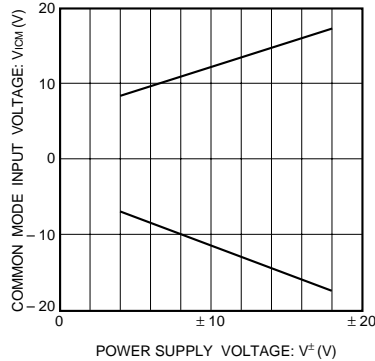

Fig.8 Common mode input voltage vs. power supply voltage

●Operation notes

(1) Unused circuit connections

If there are any circuits which are not being used, we recommend making connections as shown in Figure 9, with the non-inverted input pin connected to the potential within the in-phase input voltage range ( $V_{icm}$ ).

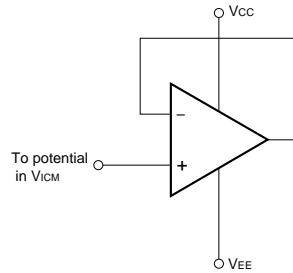
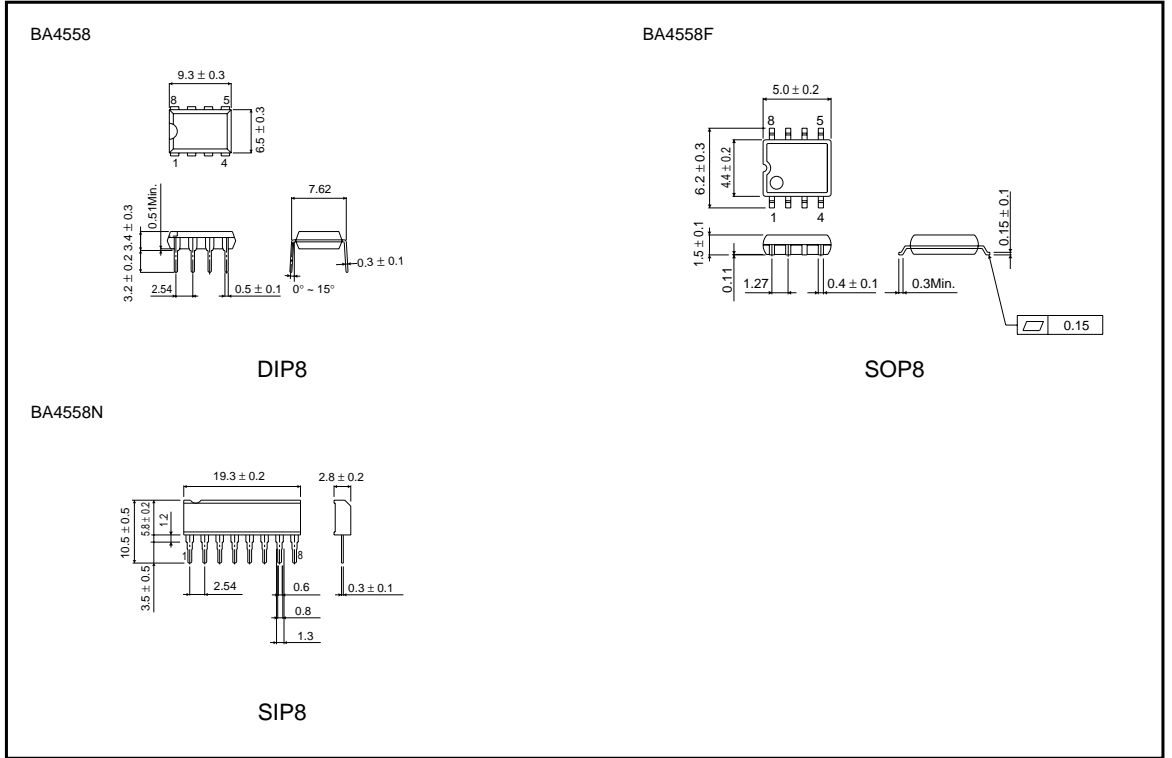

Fig.9 Unused circuit connections

●External dimensions (Units: mm)



## X-ON Electronics

Largest Supplier of Electrical and Electronic Components

*Click to view similar products for [Operational Amplifiers - Op Amps](#) category:*

*Click to view products by [ROHM](#) manufacturer:*

Other Similar products are found below :

[NCV33072ADR2G](#) [LM358SNG](#) [430227FB](#) [UPC824G2-A](#) [LT1678IS8](#) [042225DB](#) [058184EB](#) [UPC822G2-A](#) [UPC259G2-A](#) [UPC258G2-A](#)  
[NCV33202DMR2G](#) [NTE925](#) [AZV358MTR-G1](#) [AP4310AUMTR-AG1](#) [HA1630D02MMEL-E](#) [HA1630S01LPEL-E](#) [SCY33178DR2G](#)  
[NJU77806F3-TE1](#) [NCV5652MUTWG](#) [NCV20034DR2G](#) [LM324EDR2G](#) [LM2902EDR2G](#) [NTE7155](#) [NTE778S](#) [NTE871](#) [NTE924](#) [NTE937](#)  
[MCP6V17T-E/MNY](#) [MCP6V19-E/ST](#) [MXD8011HF](#) [MCP6V17T-E/MS](#) [SCY6358ADR2G](#) [ADA4523-1BCPZ](#) [LTC2065HUD#PBF](#)  
[ADA4523-1BCPZ-RL7](#) [2SD965T-R](#) [RS6332PXK](#) [BDM8551](#) [BDM321](#) [MD1324](#) [COS8052SR](#) [COS8552SR](#) [COS8554SR](#) [COS2177SR](#)  
[COS2353SR](#) [COS724TR](#) [ASOPD4580S-R](#) [RS321BKXF](#) [ADA4097-1HUJZ-RL7](#) [NCS20282FCTTAG](#)