

4-channel BTL driver for CD players

BA5937AFP

The BA5937AFP is a 4-channel BTL driver developed for use with CD players. In addition to internal drivers for the focus coil, tracking coil, and sled motor, it also contains a driver for the loading motor.

●Applications

CD-ROM, CD players

●Features

- 1) Perfect for compact applications with the use of the HSOP 28-pin power package.
- 2) Internal thermal shutdown circuit.
- 3) Gain is adjustable with externally connected resistor. (For channels 1, 3, and 4.)
- 4) External mute pin enables the muting of the output current for channels 1 and 4.
- 5) Power supply is divided into three systems (V_{cc1} = ch1 and ch4, V_{cc2} = ch2 and current source, V_{cc3} = ch3).

●Absolute maximum ratings ($T_a = 25^\circ\text{C}$)

Parameter	Symbol	Limits	Unit
Power supply voltage	V_{cc}	13.5	V
Power dissipation	P_d	1.7 *	W
Operating temperature	T_{opr}	$-35 \sim +85$	$^\circ\text{C}$
Storage temperature	T_{stg}	$-55 \sim +150$	$^\circ\text{C}$

* When mounted on a 70mm × 70mm × 1.6mm glass epoxy board with copper foil coverage of less than 3%. Reduced by 13.6mW for each increase in T_a of 1 $^\circ\text{C}$ over 25 $^\circ\text{C}$.

●Recommended operating conditions ($T_a = 25^\circ\text{C}$)

Parameter	Symbol	Limits	Unit
Power supply voltage	V_{cc}	4.5~13.2	V

● Block diagram

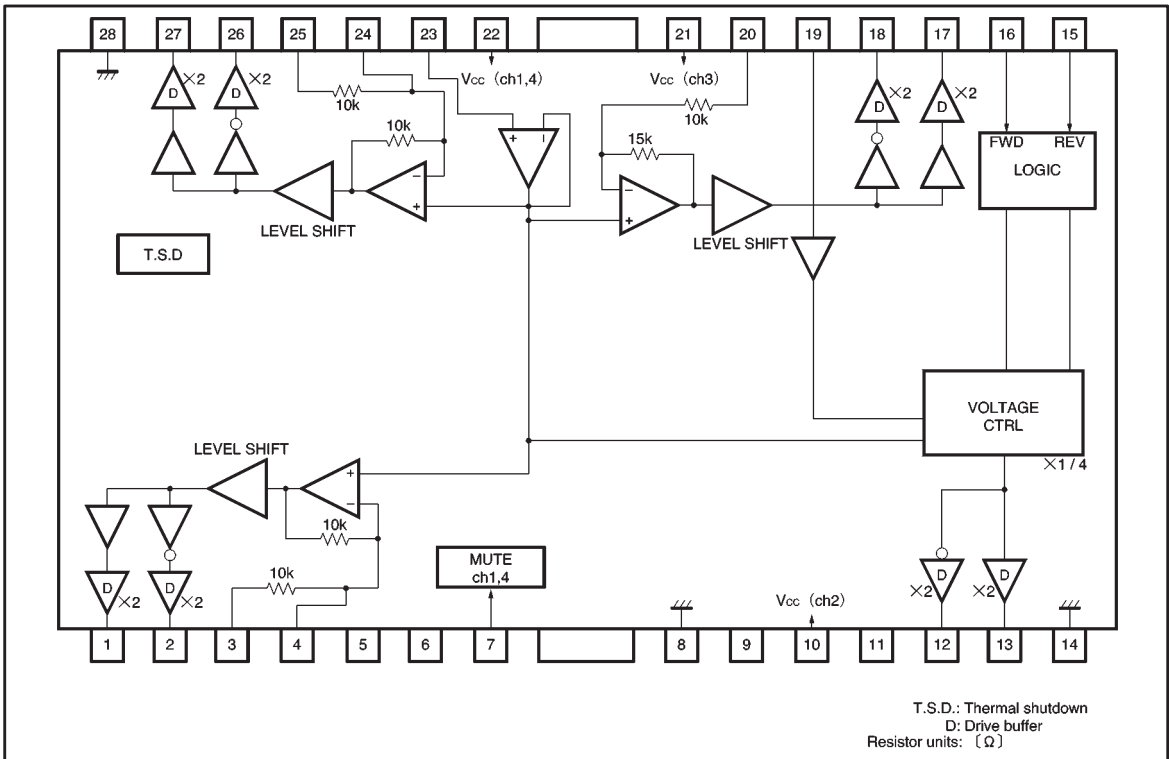

● Pin descriptions

Pin No.	Pin name	Function	Pin No.	Pin name	Function
1	OUT1-1	Channel 1 negative output	15	REV	Loading motor reverse input
2	OUT1-2	Channel 1 positive output	16	FWD	Loading motor forward input
3	IN1-1	Channel 1 input	17	OUT3-1	Channel 3 negative output
4	IN1-2	Input for channel 1 gain adjustment	18	OUT3-2	Channel 3 positive output
5	N.C.	N.C.	19	LDIN	Loading motor input
6	N.C.	N.C.	20	IN3	Channel 3 input
7	MUTE	Mute control for channels 1 and 4	21	Vcc3	Vcc (channel 3)
8	GND	GND	22	Vcc1	Vcc (channels 1 and 4)
9	N.C.	N.C.	23	VrefIN	Bias amplifier input
10	Vcc2	Vcc (channel 2)	24	IN4-2	Input for channel 4 gain adjustment
11	N.C.	N.C.	25	IN4-1	Channel 4 input
12	OUT2-2	Loading motor positive output	26	OUT4-2	Channel 4 positive output
13	OUT2-1	Loading motor negative output	27	OUT4-1	Channel 4 negative output
14	GND	Substrate GND	28	GND	Substrate GND

Note 1: Positive output and negative output are the polarities with respect to the input.

Note 2: Loading positive output and loading negative output are the polarities with respect the mode.

● Input / output circuits

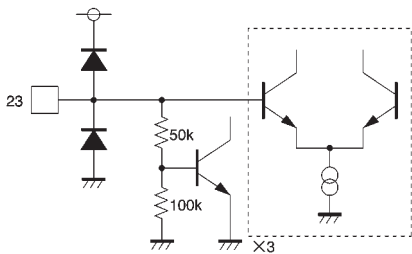
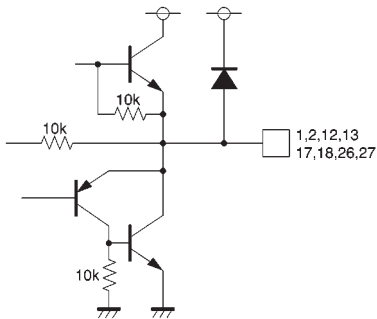
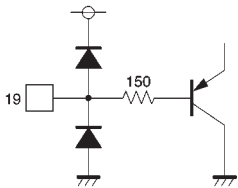
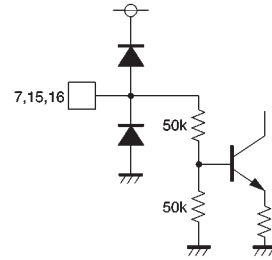
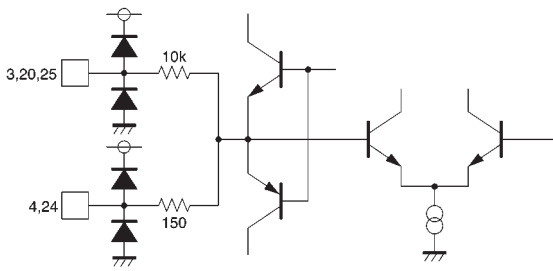

●Electrical characteristics (unless otherwise noted, $T_a = 25^\circ\text{C}$, $V_{CC} = 8\text{V}$, $R_L = 8\Omega$, $V_{BIAS} = 2.5\text{V}$)

Parameter	Symbol	Min.	Typ.	Max.	Unit	Conditions
Circuit current	I_{CC}	—	12.5	21.0	mA	No load
〈All drivers except the loading driver〉						
Output offset voltage	VOO	-40	—	40	mV	Ch1, ch3, and ch4 drivers
Maximum output pin-to-pin voltage 1	VOH1	5.4	6.0	—	V	$V_{BIAS}=4\text{V}$, $V_{IN}=8\text{V}$
Maximum output pin-to-pin voltage 2	VOH2	—	-6.0	-5.4	V	$V_{BIAS}=4\text{V}$, $V_{IN}=0.7\text{V}$
Closed-loop voltage gain 1	GVC1	9.5	11.5	13.5	dB	$V_{IN}=V_{BIAS}\pm 0.5\text{V}$, ch1, 4
Closed-loop voltage gain 2	GVC2	13.0	15.0	17.0	dB	$V_{IN}=V_{BIAS}\pm 0.5\text{V}$, ch3
Ripple rejection	RR	—	60	—	dB	$V_{IN}=0.1\text{V}_{\text{rms}}$, 100Hz
Mute on voltage	VMON	2.0	—	—	V	
Mute off voltage	VMOFF	—	—	0.5	V	
〈Loading driver〉						
Voltage between outputs F	VOF	2.0	2.6	3.2	V	$V_{CC}=8\text{V}$, $R_L=8\Omega$, $LDIN=2.5\text{V}$
Voltage between outputs R	VOR	-3.1	-2.5	-1.9	V	
Output voltage range F	VOMF	2.5	3.2	—	V	$V_{CC}=5\text{V}$, $R_L=8\Omega$, $LDIN=4.5\text{V}^{*1}$
Output voltage range R	VOMR	—	-3.2	-2.5	V	
Output load regulation F1	$\Delta VF1$	—	100	500	mV	$V_{CC}=8\text{V}$, $LDIN=3.0\text{V}$
Output load regulation R1	$\Delta VR1$	—	100	500	mV	$I=100\rightarrow 400\text{mA}^{*2}$
Output load regulation F2	$\Delta VF2$	—	150	850	mV	$V_{CC}=5\text{V}$, $LDIN=OPEN$
Output load regulation R2	$\Delta VR2$	—	150	850	mV	$I=100\rightarrow 400\text{mA}^{*2}$
Power supply voltage regulation F	ΔVFL	-500	—	500	mV	$V_{CC}=5\text{V}\rightarrow 13\text{V}$, $R_L=\infty$
Power supply voltage regulation R	ΔVRL	-500	—	500	mV	
Output offset voltage	VOOL	-50	—	50	mV	During braking; voltage between outputs
〈Controller FWD REV pins〉						
Input high level voltage 1	VIH1	2.0	—	—	V	FWD (16pin), REV (15pin)
Input low level voltage 1	VIL1	—	—	0.5	V	Voltage at input pins
Input high level current	IIH	—	—	500	μA	$V_{IN}=5\text{V}$
Input low level current	IIL	—	—	500	μA	$V_{IN}=0\text{V}$

©Not designed for radiation resistance.

*1 Even if the loading input (pin 19) LDIN is open, VOMF and VOMR remain approximately the same.

*2 $\Delta VF1$ and $\Delta VR1$ perform load regulation with 3.0V output without the output clipping.

In order to open the input during reduced supply voltage of 5V, $\Delta VF2$ and $\Delta VR2$ clip the output. Load regulation is performed in this condition.

● Measurement circuit

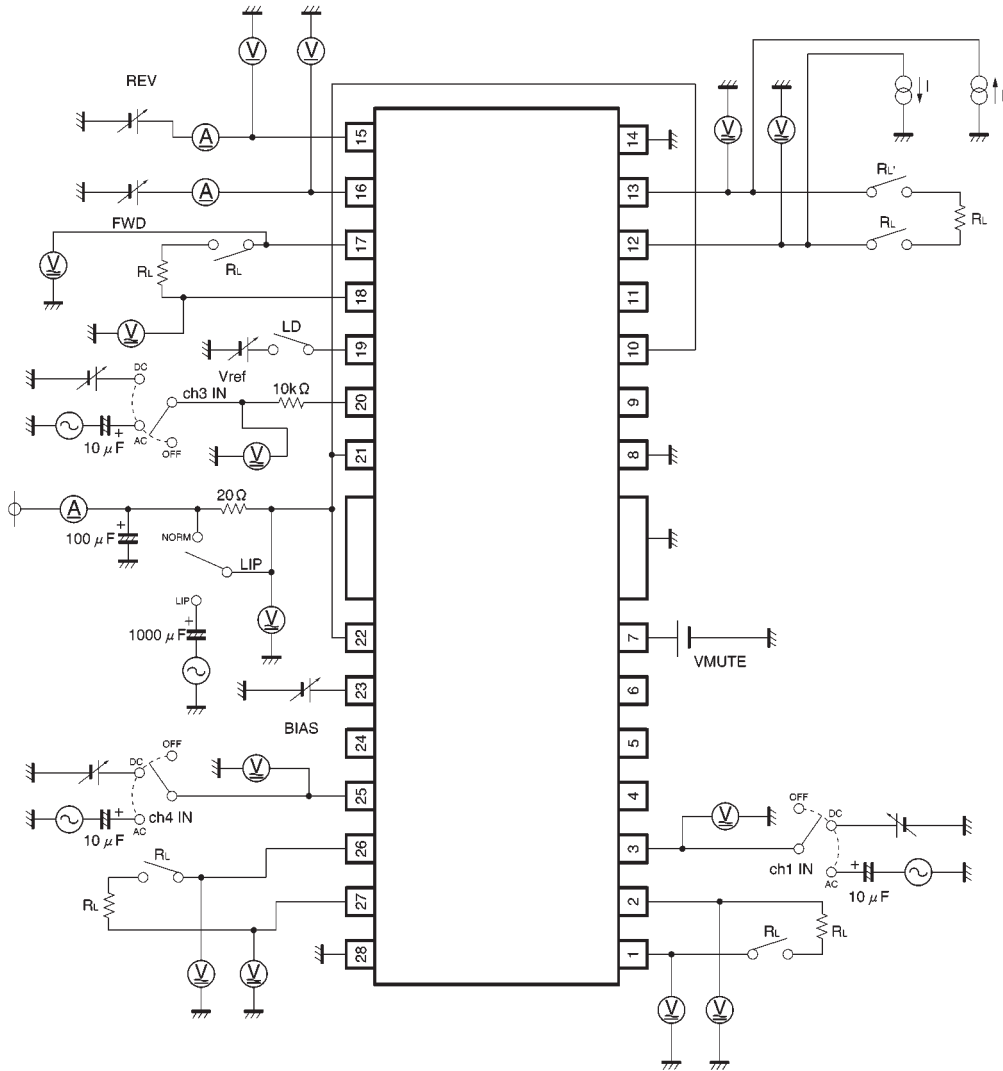

Fig.1

●Application example

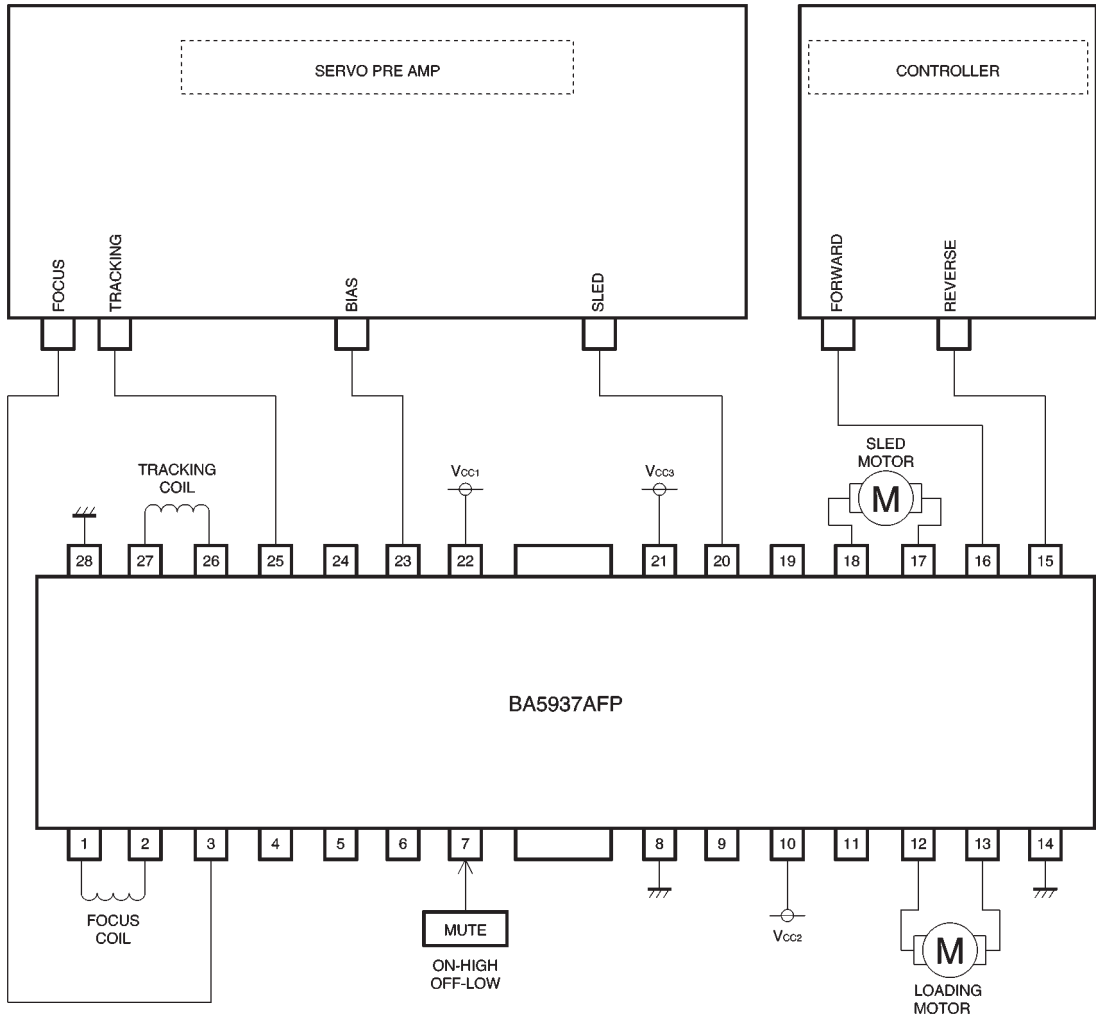

Fig.2

● Operation notes

(1) Output mode switch for loading motor driver ($V_{CC} = 8V$)

FWD	REV	Loading output	Refer to
L	L	High impedance	Fig.3
	H	Reverse	Fig.4
H	L	Forward	Fig.5
	H	Brake	Fig.6

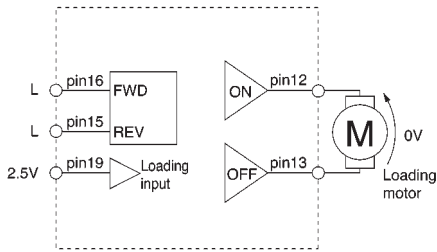

Fig.3

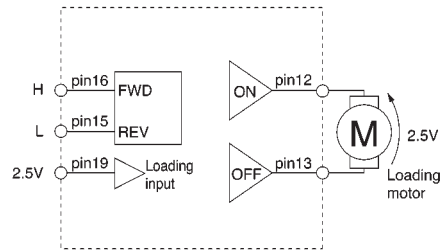

Fig.4

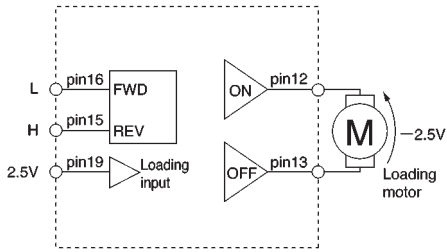

Fig.5

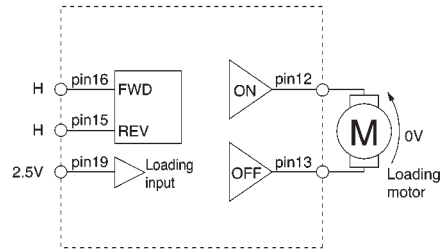

Fig.6

Note: Loading driver gain is 0dB.

(2) Voltage setting for loading motor driver (ex: forward mode)

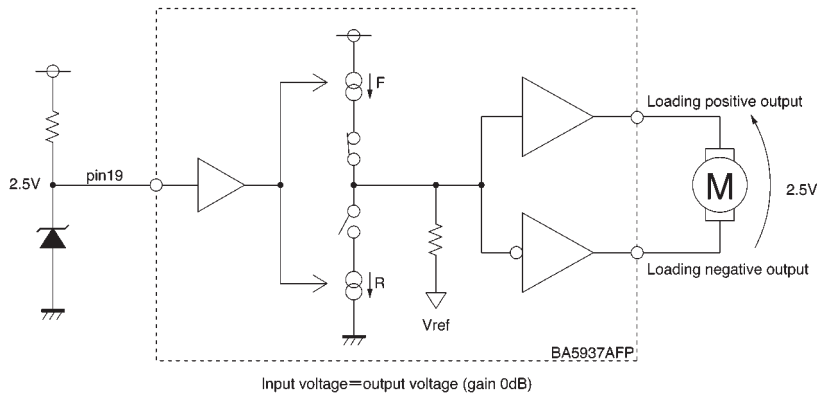

Fig.7

*When setting the output voltage from the loading driver, even if an output voltage is set that exceeds the maximum output voltage with respect to the power supply voltage, the output will not exceed the maximum output voltage.

If a voltage is set that is under the maximum output voltage, the example above is applicable. Also, by having the loading input (pin 19) open, the maximum output voltage with respect to the power supply voltage is output.

(3) The BA5937AFP contains a thermal shutdown circuit.

When the chip temperature reaches 175°C (Typ.), the output current is muted. If the chip temperature then drops below 150°C (Typ.), then the mute is released.

(4) If the voltage of the bias pin (pin 23) drops below 1.0V (Typ.), outputs are muted.

For normal conditions, have the voltage above 1.4V and below 6.5V.

(5) By having the mute pin (pin 7) voltage pulled up to 2.0V or greater, you can mute the output current for channels 1 and 4. For normal conditions, have pin 7 open or at 0.5V or below.

(6) If the voltage of the thermal shutdown, mute ON, or bias pin drops, the mute is activated; however, in these situations, only the drivers are muted. Also, the output pin voltage becomes the internal bias voltage (approx. $(V_{CC} - VF)/2$).

(7) Connect a bypass capacitor (approx. 0.1μF) between the bases of the power supply pins of this IC.

(8) Even though the radiation fins are connected to ground within the package, be sure to also connect them to a ground externally as well.

●Electrical characteristic curves

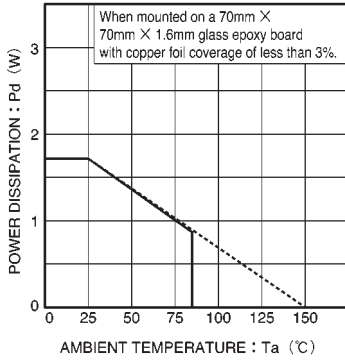

Fig.8 Thermal derating curve

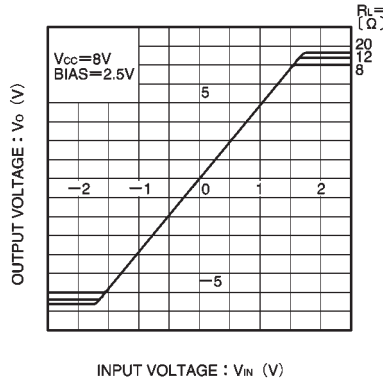

Fig.9 Driver I/O characteristics (channels 1 and 4) (during load regulation)

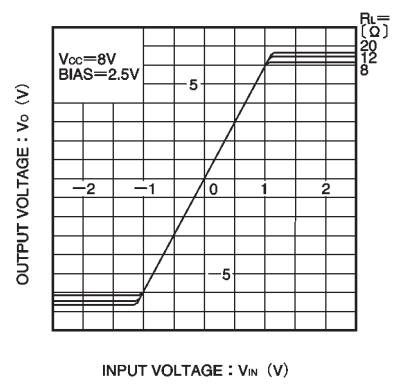

Fig.10 Driver I/O characteristics (channel 3) (during load regulation)

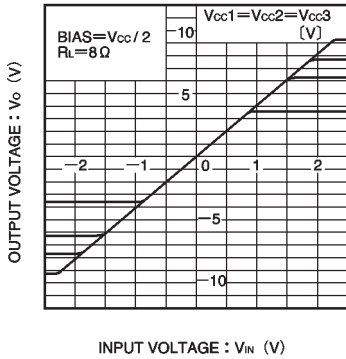

Fig.11 Driver I/O characteristics (channels 1 and 4) (during Vcc regulation)

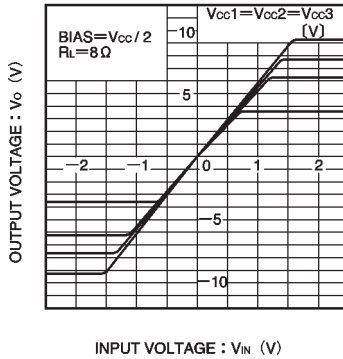

Fig.12 Driver I/O characteristics (channel 3) (during Vcc regulation)

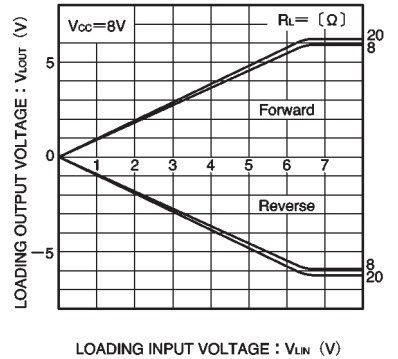
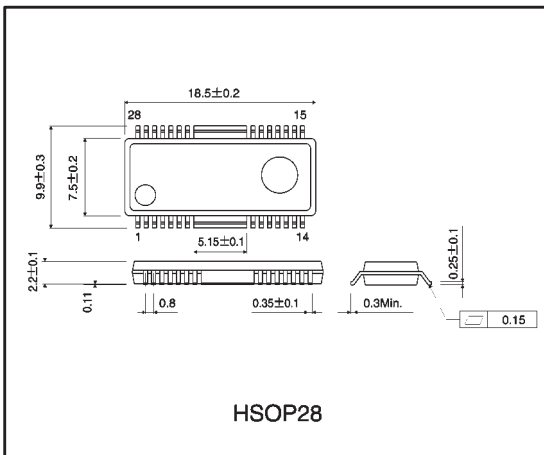

Fig.13 Loading I/O characteristics

●External dimensions (Units: mm)



X-ON Electronics

Largest Supplier of Electrical and Electronic Components

Click to view similar products for [Motor/Motion/Ignition Controllers & Drivers](#) category:

Click to view products by [ROHM](#) manufacturer:

Other Similar products are found below :

[FSB50550TB2](#) [FSBF15CH60BTH](#) [MSVCPM2-63-12](#) [MSVGW45-14-2](#) [MSVGW54-14-3](#) [MSVGW54-14-5](#) [NTE7043](#) [LA6565VR-TLM-E](#)
[LB11650-E](#) [LB1837M-TLM-E](#) [LB1845DAZ-XE](#) [LC898300XA-MH](#) [SS30-TE-L-E](#) [26700](#) [LV8281VR-TLM-H](#) [BA5839FP-E2](#) [IRAM236-1067A](#) [LA6584JA-AH](#) [LB11847L-E](#) [NCV70501DW002R2G](#) [AH293-PL-B](#) [STK672-630CN-E](#) [TND315S-TL-2H](#) [FNA23060](#) [FSB50250AB](#)
[FNA41060](#) [MSVB54](#) [MSVBTC50E](#) [MSVCPM3-54-12](#) [MSVCPM3-63-12](#) [MSVCPM4-63-12](#) [MSVTA120](#) [FSB50550AB](#)
[NCV70501DW002G](#) [LC898301XA-MH](#) [LV8413GP-TE-L-E](#) [MSVGW45-14-3](#) [MSVGW45-14-4](#) [MSVGW45-14-5](#) [MSVGW54-14-4](#)
[STK984-091A-E](#) [MP6519GQ-Z](#) [LB11651-E](#) [IRSM515-025DA4](#) [LV8127T-TLM-H](#) [MC33812EKR2](#) [NCP81382MNTXG](#) [TDA21801](#)
[LB11851FA-BH](#) [NCV70627DQ001R2G](#)