

Stepping motor driver

BA6845FS

The BA6845FS is a stepping motor driver with a maximum output current of 1.0A. The logic input allows three output modes : forward, reverse, and power save. The IC has a low output saturation voltage and is capable of driving motors at low supply voltage.

●Applications

Stepping motors for floppy disk drives

●Features

- 1) Low output saturation voltage.
- 2) Power save circuit.
- 3) Thermal shutdown circuit.

●Absolute maximum ratings (Ta = 25°C)

Parameter	Symbol	Limits	Unit
Applied voltage	V _{CC}	12	V
Power dissipation	P _d	800* ¹	mW
Operating temperature	T _{opr}	-25~+75	°C
Storage temperature	T _{stg}	-55~+150	°C
Allowable output current	I _{oMax.}	1000* ²	mA

*1 When mounted on a glass epoxy PCB (90 X 50 X 1.6 mm) board.

Reduced by 6.4 mW for each increase in Ta of 1°C over 25°C.

*2 Should not exceed Pd- or ASO-value.

●Recommended operating conditions (Ta = 25°C)

Parameter	Symbol	Limits	Unit
Power supply voltage	V _{CC}	2.7~9.0	V

●Block diagram

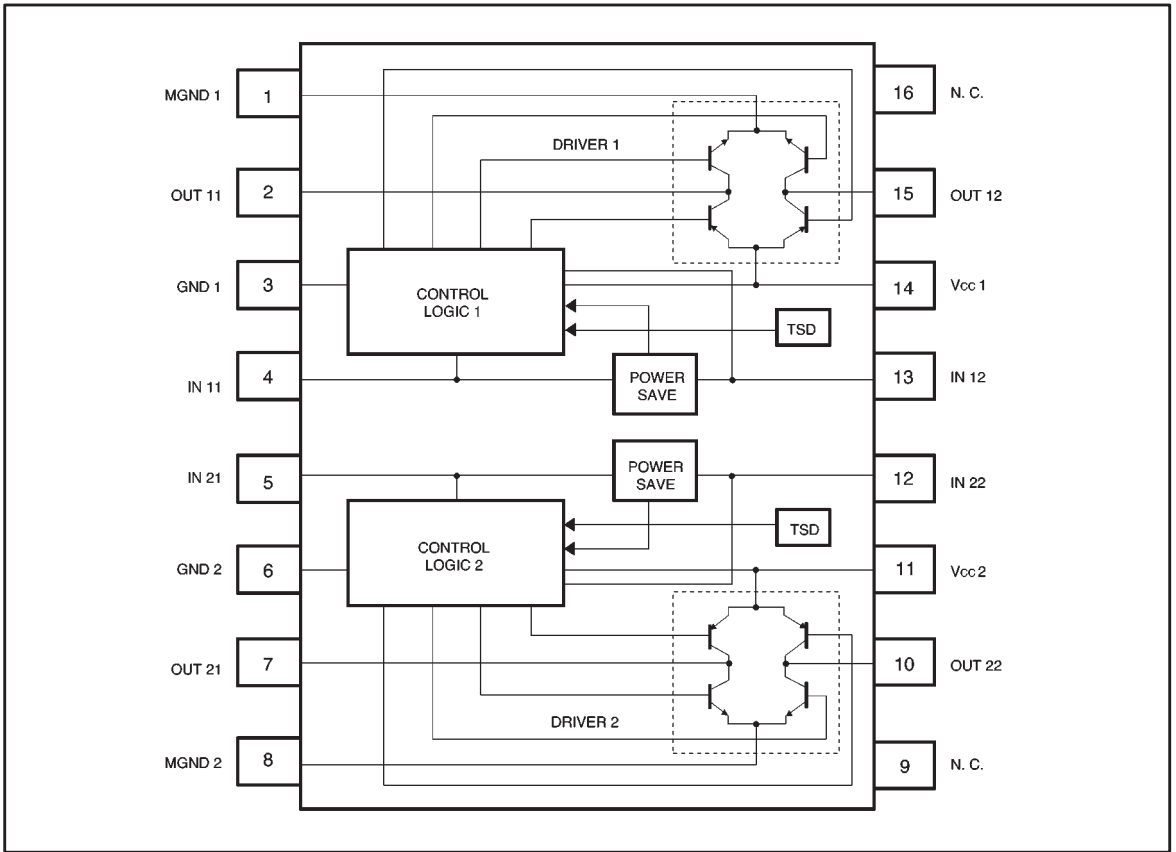

● Pin descriptions

Pin No.	Pin name	Function
1	MGND 1	Motor ground
2	OUT 11	Motor output
3	GND 1	Ground
4	IN 11	Logic input
5	IN 21	Logic input
6	GND 2	Ground
7	OUT 21	Motor output
8	MGND 2	Motor ground
9	N. C.	N. C.
10	OUT 22	Motor output
11	V _{CC} 2	Power supply
12	IN 22	Logic input
13	IN 12	Logic input
14	V _{CC} 1	Power supply
15	OUT 12	Motor output
16	N. C.	N. C.

● Input / output circuits (all resistances are typical values)

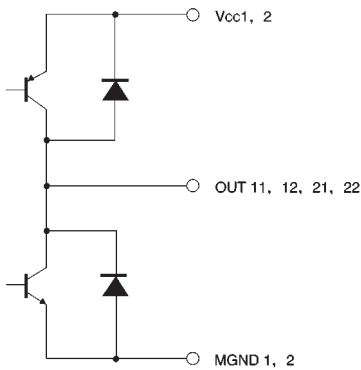
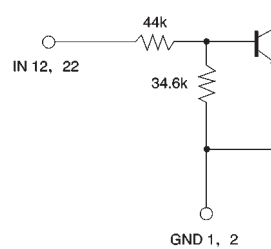
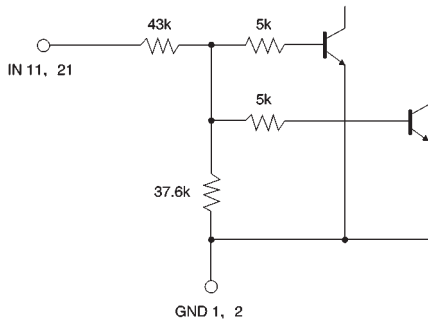

●Electrical characteristics (unless otherwise noted, $T_a = 25^\circ\text{C}$, $V_{CC} = 5\text{V}$)

Parameter	Symbol	Min.	Typ.	Max.	Unit	Conditions
Supply current 1	I_{CC1}	—	55	80	mA	$IN12=IN22=5\text{V}$
Supply current 2	I_{CC2}	—	—	10	μA	$IN12=IN22=0\text{V}$
Output saturation voltage	V_{sat}	—	0.5	0.7	V	$I_{\text{OUT}}=400\text{mA}$, sum of the high-and low-side voltage
Input threshold voltage	V_{IN}	1.0	1.5	2.1	V	
Input current	I_{IN}	—	100	150	μA	$IN11, 12, 21, 22=5\text{V}$

◎Not designed for radiation resistance.

●Truth table

IN11 / 21	IN12 / 22	OUT11 / 21	OUT12 / 22	Mode
L	H	H	L	Forward
H	H	L	H	Reverse
L	L	OPEN	OPEN	Stop
H	L	OPEN	OPEN	Stop

●Application example

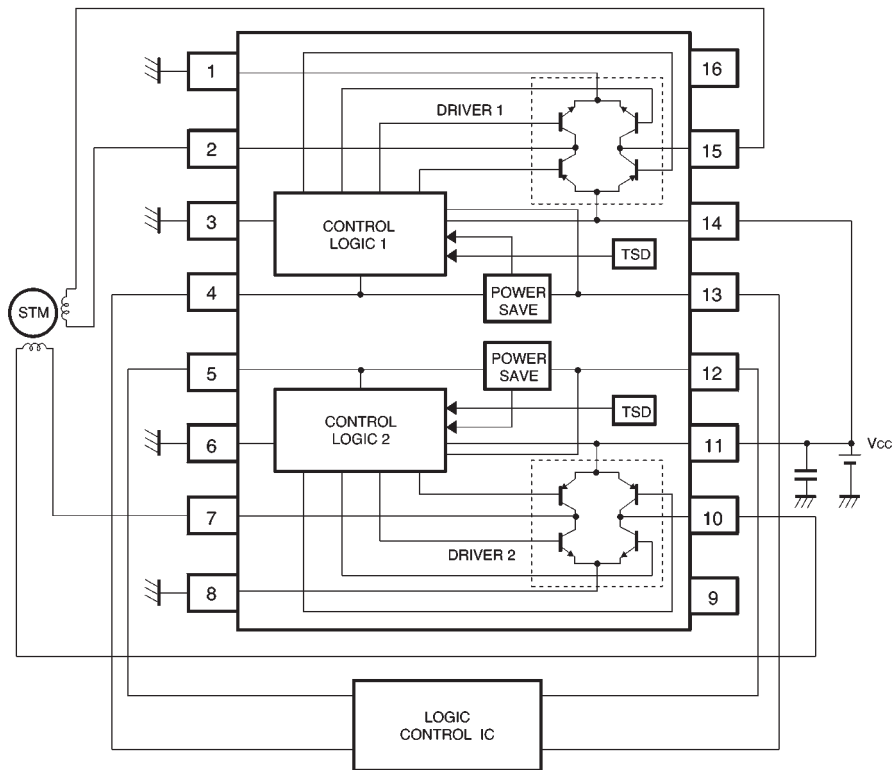

Fig.1

●Operation notes

(1) Control logic pins

Do not apply voltage to control logic pins (pins 4, 5, 12, and 13) when the V_{CC} voltage is not applied to the IC. The voltage of each pin should be less than V_{CC} , if applied, and should be more than the ground voltage.

(2) PCB arrangement

When changing the rotational direction of a motor, a large current of up to a few hundred milliamperes can flow between the motor power supply (pins 11 and 14) and MGND (pins 1 and 8). Depending on the application, this large output current may flow back to input pins, resulting in output oscillation or other malfunctions. Make sure that your design does not allow a common impedance between the large current output lines and the input section. Suppress the power supply impedance to low levels, otherwise output oscillation may occur.

(3) Package power dissipation

The power dissipated by the IC varies widely with the supply voltage and the output current. Give full consideration to the package power dissipation rating when setting the supply voltage and the output current.

(4) Ground pins

Pins 1, 3, 6, and 8 should have the lowest potential (ground potential) in the IC.

(5) Thermal shutdown circuit

This circuit shuts down all the driver outputs when the chip junction temperature is increased to about 175°C (typical). The thermal shutdown circuit is deactivated when the temperature drops to about 20°C (typical).

(6) Input pins (pins 4, 5, 12, and 13)

These pins have characteristics negatively correlated to temperature. Give full consideration to the temperature effect when using the IC.

● Electrical characteristic curves

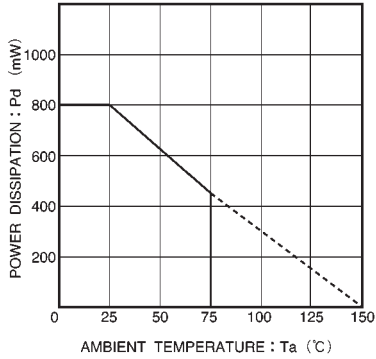

Fig.2 Power dissipation curve

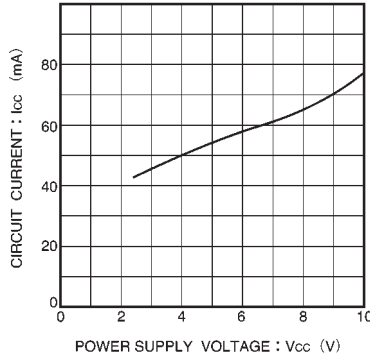

Fig.3 Circuit current vs. power supply voltage

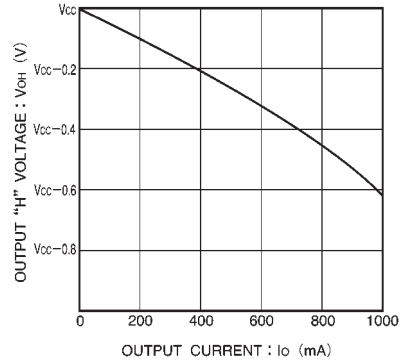

Fig.4 HIGH level output voltage vs. output current

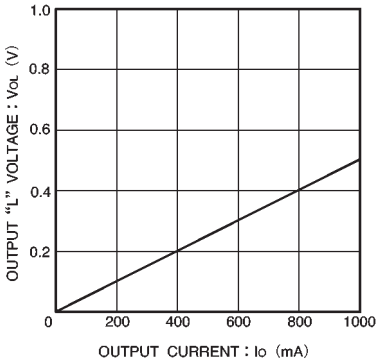
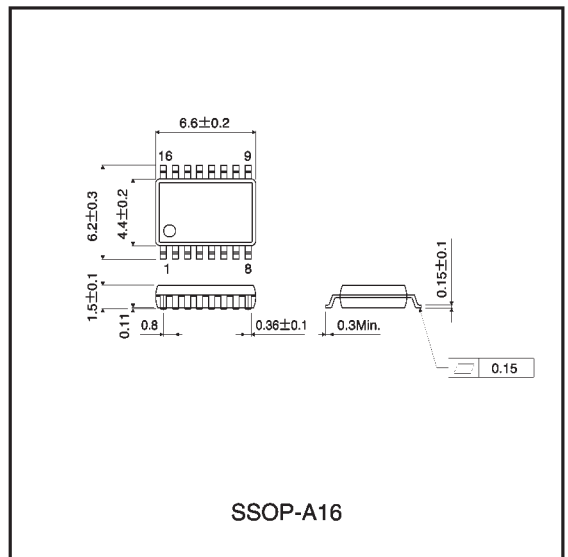

Fig.5 LOW level output voltage vs. output current

● External dimensions (Units: mm)



- The contents described herein are subject to change without notice. The specifications for the product described in this document are for reference only. Upon actual use, therefore, please request that specifications to be separately delivered.
- Application circuit diagrams and circuit constants contained herein are shown as examples of standard use and operation. Please pay careful attention to the peripheral conditions when designing circuits and deciding upon circuit constants in the set.
- Any data, including, but not limited to application circuit diagrams information, described herein are intended only as illustrations of such devices and not as the specifications for such devices. ROHM CO.,LTD. disclaims any warranty that any use of such devices shall be free from infringement of any third party's intellectual property rights or other proprietary rights, and further, assumes no liability of whatsoever nature in the event of any such infringement, or arising from or connected with or related to the use of such devices.
- Upon the sale of any such devices, other than for buyer's right to use such devices itself, resell or otherwise dispose of the same, no express or implied right or license to practice or commercially exploit any intellectual property rights or other proprietary rights owned or controlled by
- ROHM CO., LTD. is granted to any such buyer.
- Products listed in this document use silicon as a basic material.
Products listed in this document are no antiradiation design.

The products listed in this document are designed to be used with ordinary electronic equipment or devices (such as audio visual equipment, office-automation equipment, communications devices, electrical appliances and electronic toys).

Should you intend to use these products with equipment or devices which require an extremely high level of reliability and the malfunction of which would directly endanger human life (such as medical instruments, transportation equipment, aerospace machinery, nuclear-reactor controllers, fuel controllers and other safety devices), please be sure to consult with our sales representative in advance.

About Export Control Order in Japan

Products described herein are the objects of controlled goods in Annex 1 (Item 16) of Export Trade Control Order in Japan.

In case of export from Japan, please confirm if it applies to "objective" criteria or an "informed" (by MITI clause) on the basis of "catch all controls for Non-Proliferation of Weapons of Mass Destruction.

X-ON Electronics

Largest Supplier of Electrical and Electronic Components

Click to view similar products for [Motor/Motion/Ignition Controllers & Drivers](#) category:

Click to view products by [ROHM](#) manufacturer:

Other Similar products are found below :

[FSB50550TB2](#) [FSBF15CH60BTH](#) [MSVCPM2-63-12](#) [MSVGW45-14-2](#) [MSVGW54-14-3](#) [MSVGW54-14-5](#) [NTE7043](#) [LA6565VR-TLM-E](#)
[LB11650-E](#) [LB1837M-TLM-E](#) [LB1845DAZ-XE](#) [LC898300XA-MH](#) [SS30-TE-L-E](#) [26700](#) [LV8281VR-TLM-H](#) [BA5839FP-E2](#) [IRAM236-1067A](#) [LA6584JA-AH](#) [LB11847L-E](#) [AH293-PL-B](#) [TND315S-TL-2H](#) [FNA23060](#) [FSB50250AB](#) [FNA41060](#) [MSVB54](#) [MSVBTC50E](#)
[MSVCPM3-54-12](#) [MSVCPM3-63-12](#) [MSVCPM4-63-12](#) [MSVTA120](#) [FSB50550AB](#) [NCV70501DW002G](#) [LC898301XA-MH](#) [LV8413GP-TE-L-E](#) [MSVGW45-14-3](#) [MSVGW45-14-4](#) [MSVGW45-14-5](#) [MSVGW54-14-4](#) [STK984-091A-E](#) [SLA7026M](#) [MP6519GQ-Z](#) [LB11651-E](#)
[IRSM515-025DA4](#) [LV8127T-TLM-H](#) [MC33812EKR2](#) [NCP81382MNTXG](#) [TDA21801](#) [LB11851FA-BH](#) [NCV70627DQ001R2G](#)
[LB1938FAGEVB](#)