

- Structure : Silicon Monolithic Integrated Circuit
- Product name : Single Output Video Drivers with built-in Input Selector
- Type : **BA7615N**
- Features :
 - 1) Built-in mute function
 - 2) Wide operation power supply voltage range
 - 3) Good frequency characteristics (Typ.10 MHz, 0 dB)
 - 4) Wide dynamic range (Typ. 3.5 Vp-p, Vcc=5.0 V)
 - 5) Sync-tip clamp input
 - 6) Low interchannel crosstalk (Typ.-65 dB, f=4.43 MHz)
 - 7) Built-in short circuit protection function

○Absolute Maximum Ratings (Ta=25°C)

Parameter	Symbol	Limits	Unit
Supply voltage	Vcc	13.5	V
Power dissipation	Pd	850 *1	mW
Operating temperature	Topr	-30~+75 *2	°C
Storage temperature	Tstg	-55~+125	°C

*1 Deratings is done at 8.5mW/°C above Ta=25°C.

*2 From -25°C to +85°C if the supply voltage is use with 9.0V from 4.5V, the operating temperature permits.

○Operating Range (Ta=25°C)

Parameter	Symbol	Min	Typ	Max	Unit
Power supply voltage	Vcc	4.5	5.0	13.0	V

* This product is not designed for protection against radioactive rays.

Application example

The product described in this specification is designed to be used with ordinary electronic equipment or devices (such as audio-visual equipment, office-automation equipment, communications devices, electrical appliances, and electronic toys). Should you intend to use this product with equipment or devices which require an extremely high level of reliability and the malfunction of which would directly endanger human life (such as medical instruments, transportation equipment, aerospace machinery, nuclear-reactor controllers, fuel controllers and other safety devices), please be sure to consult with our sales representative in advance.

○Electrical characteristics (Unless otherwise noted, Ta= 25°C, Vcc=5.0V)

Parameter	Symbol	Min.	Typ.	Max.	Unit	Conditions
Circuit current	I _{CC}	-	19.5	29.0	mA	No signal
Maximum output level	V _{OM}	3.0	3.5	-	V _{p-p}	f=1kHz, THD=0.5%
Voltage gain	G _V	5.5	6.0	6.5	dB	f=1MHz, 1V _{p-p}
Frequency characteristic	G _F	-3.0	0.0	1.0	dB	f=10MHz/1MHz, 1V _{p-p}
Interchannel crosstalk	C _T	-	-65	-	dB	f=4.43MHz, 1V _{p-p}
CTL pin switching level A	V _{THA}	1.0	2.0	3.0	V	CTLA(2PIN) threshold voltage
CTL pin switching level B	V _{THB}	1.0	2.0	3.0	V	CTLB(3PIN) threshold voltage
CTL pin switching level C	V _{THC}	1.0	2.0	3.0	V	CTLC(5PIN) threshold voltage

○Block diagram

○Pin number and pin name

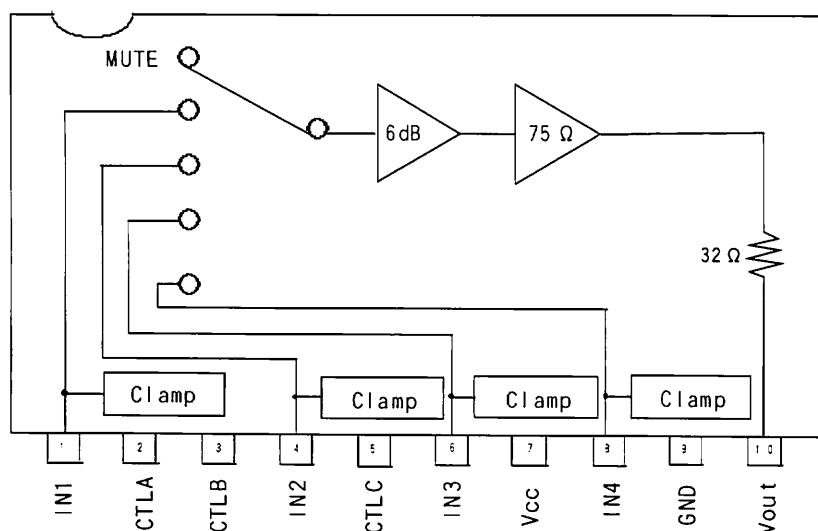

Pin No.	Pin name
1	IN1
2	CTLA
3	CTLB
4	IN2
5	CTLC
6	IN3
7	Vcc
8	IN4
9	GND
10	Vout

○Outer dimensions

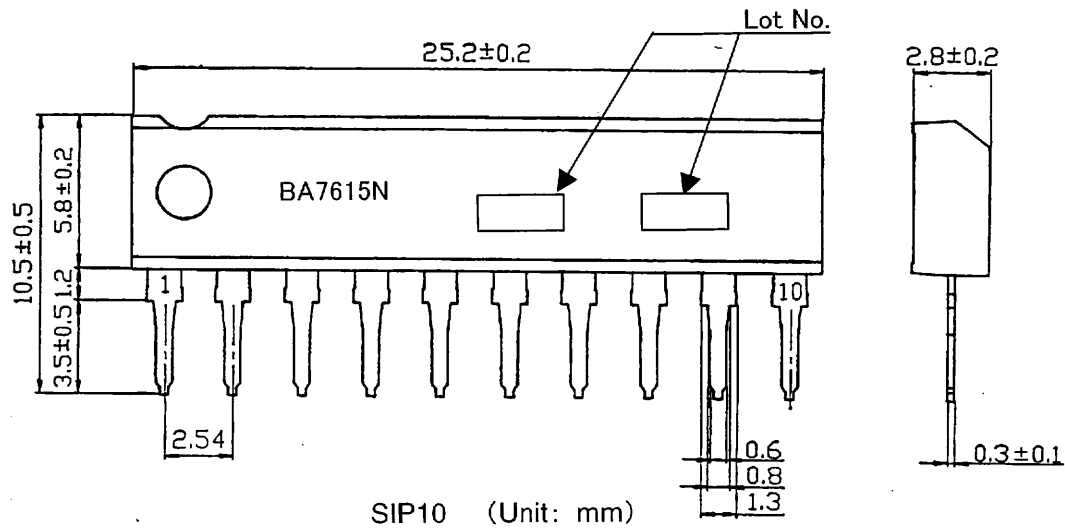

○Cautions on use

1) Absolute maximum ratings

If applied voltage, operating temperature range, or other absolute maximum ratings are exceeded, the LSI may be damaged. Do not apply voltages or temperatures that exceed the absolute maximum ratings. If you think of a case in which absolute maximum ratings are exceeded, enforce fuses or other physical safety measures and investigate how not to apply the conditions under which absolute maximum ratings are exceeded to the LSI.

2) GND potential

Make the GND pin voltage such that it is the lowest voltage even when operating below it. Actually confirm that the voltage of each pin does not become a lower voltage than the GND pin, including transient phenomena.

3) Thermal design

Perform thermal design in which there are adequate margins by taking into account the allowable power dissipation in actual states of use.

4) Shorts between pins and miss-installation

When mounting the LSI on a board, pay adequate attention to orientation and placement discrepancies of the LSI. If it is miss-installed and the power is turned on, the LSI may be damaged. It also may be damaged if it is shorted by a foreign substance coming between pins of the LSI or between a pin and a power supply or a pin and a GND.

5) Operation in strong magnetic fields

Adequately evaluate use in a strong magnetic field, since there is a possibility of malfunction.

Notes

- No technical content pages of this document may be reproduced in any form or transmitted by any means without prior permission of ROHM CO.,LTD.
- The contents described herein are subject to change without notice. The specifications for the product described in this document are for reference only. Upon actual use, therefore, please request that specifications to be separately delivered.
- Application circuit diagrams and circuit constants contained herein are shown as examples of standard use and operation. Please pay careful attention to the peripheral conditions when designing circuits and deciding upon circuit constants in the set.
- Any data, including, but not limited to application circuit diagrams information, described herein are intended only as illustrations of such devices and not as the specifications for such devices. ROHM CO.,LTD. disclaims any warranty that any use of such devices shall be free from infringement of any third party's intellectual property rights or other proprietary rights, and further, assumes no liability of whatsoever nature in the event of any such infringement, or arising from or connected with or related to the use of such devices.
- Upon the sale of any such devices, other than for buyer's right to use such devices itself, resell or otherwise dispose of the same, no express or implied right or license to practice or commercially exploit any intellectual property rights or other proprietary rights owned or controlled by
- ROHM CO., LTD. is granted to any such buyer.
- Products listed in this document are no antiradiation design.

The products listed in this document are designed to be used with ordinary electronic equipment or devices (such as audio visual equipment, office-automation equipment, communications devices, electrical appliances and electronic toys).

Should you intend to use these products with equipment or devices which require an extremely high level of reliability and the malfunction of which would directly endanger human life (such as medical instruments, transportation equipment, aerospace machinery, nuclear-reactor controllers, fuel controllers and other safety devices), please be sure to consult with our sales representative in advance.

About Export Control Order in Japan

Products described herein are the objects of controlled goods in Annex 1 (Item 16) of Export Trade Control Order in Japan.

In case of export from Japan, please confirm if it applies to "objective" criteria or an "informed" (by MITI clause) on the basis of "catch all controls for Non-Proliferation of Weapons of Mass Destruction.

Thank you for your accessing to ROHM product informations.
More detail product informations and catalogs are available,
please contact your nearest sales office.

Please contact our sales offices for details ;

U.S.A / San Diego	TEL : +1(858)625-3630	FAX : +1(858)625-3670
Atlanta	TEL : +1(770)754-5972	FAX : +1(770)754-0691
Dallas	TEL : +1(972)312-8818	FAX : +1(972)312-0330
Germany / Dusseldorf	TEL : +49(2154)9210	FAX : +49(2154)921400
United Kingdom / London	TEL : +44(1)908-282-666	FAX : +44(1)908-282-528
France / Paris	TEL : +33(0)1 56 97 30 60	FAX : +33(0) 1 56 97 30 80
China / Hong Kong	TEL : +852(2)740-6262	FAX : +852(2)375-8971
Shanghai	TEL : +86(21)6279-2727	FAX : +86(21)6247-2066
Dilian	TEL : +86(411)8230-8549	FAX : +86(411)8230-8537
Beijing	TEL : +86(10)8525-2483	FAX : +86(10)8525-2489
Taiwan / Taipei	TEL : +866(2)2500-6956	FAX : +866(2)2503-2869
Korea / Seoul	TEL : +82(2)8182-700	FAX : +82(2)8182-715
Singapore	TEL : +65-6332-2322	FAX : +65-6332-5662
Malaysia / Kuala Lumpur	TEL : +60(3)7958-8355	FAX : +60(3)7958-8377
Philippines / Manila	TEL : +63(2)807-6872	FAX : +63(2)809-1422
Thailand / Bangkok	TEL : +66(2)254-4890	FAX : +66(2)256-6334

Japan /
(Internal Sales)

Tokyo	2-1-1, Yaesu, Chuo-ku, Tokyo 104-0082	TEL : +81(3)5203-0321	FAX : +81(3)5203-0300
Yokohama	2-4-8, Shin Yokohama, Kohoku-ku, Yokohama, Kanagawa 222-8575	TEL : +81(45)476-2131	FAX : +81(45)476-2128
Nagoya	Dainagayo Building 9F 3-28-12, Meieki, Nakamura-ku, Nagoya, Aichi 450-0002	TEL : +81(52)581-8521	FAX : +81(52)561-2173
Kyoto	579-32 Higashi Shiokouji-cho, Karasuma Nishi-iru, Shiokoujiodori, Shimogyo-ku, Kyoto 600-8216	TEL : +81(75)311-2121	FAX : +81(75)314-6559
(Contact address for overseas customers in Japan)			
Yokohama		TEL : +81(45)476-9270	FAX : +81(045)476-9271

X-ON Electronics

Largest Supplier of Electrical and Electronic Components

Click to view similar products for [Display Drivers & Controllers](#) category:

Click to view products by [ROHM](#) manufacturer:

Other Similar products are found below :

[ICB2FL01G](#) [LC74761M-9006-E](#) [MP3360DG-LF-P](#) [HV5812PJ-G-M904](#) [TW8813-LB2-GR](#) [TW8819AT-NA2-GR](#) [TW8811-PC2-GR](#)
[MAX1839EEP+](#) [TW9907-TA1-GR](#) [S1D13503F00A200](#) [MAX7370ETG+T](#) [LX27901IDW](#) [STVM100DC6F](#) [DS3994Z+T&R](#)
[S1D13515F00A100](#) [LX1686EIPW](#) [AM26C32IDR](#) [MAX7370ETG+](#) [LX1688IPW](#) [MAX1739EEP+](#) [MAX17126BETM+](#)
[MAX14515AEWA+T](#) [DS3992Z-18P](#) [BTM7710GXUMA1](#) [DS3881E+C](#) [S1D13742F01A200](#) [LX1688CPW](#) [MAX17126AETM+](#)
[MAX8729EEI+](#) [MAX7370ETG](#) [TIOS1013DMWR](#) [TLD5097EL](#) [HV857LK7-G](#) [TLD5097ELXUMA1](#) [AAT2823IBK-1-T1](#) [DLPA1000YFFT](#)
[ICB2FL01GXUMA2](#) [DLP2000FQC](#) [SC401U](#) [IR2117PBF](#) [PAD1000YFFR](#) [S1D13746F01A600](#) [S1D13748B00B100](#) [FIN324CMLX](#)
[STVM100DS6F](#) [HV850MG-G](#) [AD8138ARZ-R7](#) [AD8387JSVZ](#) [ADDI9023BBCZ](#) [ADM3202ARUZ-REEL7](#)