

Three Phase Motor Predriver IC for automotive



Built-in the Phase adjustment control and 180°energizing drive Three Phase Motor Predriver

BD16805FV-M

●General Description

BD16805FV-M is three phase motor driver for air conditioner blower motor, battery cooling fan motor, and seat cooling fan motor. This IC can implement silent drive by 180° energizing drive. The BD16805FV-M includes a built-in phase adjustment control function to drive highly effective. The setting that can correspond to various motor controls is possible. (PWM frequency, Overcurrent protection limit, Start time and Lock protection)

●Features

- AEC-Q100 Qualified
- 180° energizing
- Phase adjustment control
- Built-in charge pump
- Built-in MUTE return and uptime setting
- Normal rotation/reversal rotation switch function
- 1FG/3FG switch function
- Speed control by DC input and PWM input
- Output mode can be selected
- Built-in overcurrent protection circuit(OCP) (With limit adjustment function)
- Lock protection function
- Built-in under voltage protection circuit(UVLO)
- Built-in over voltage protection circuit(OVP)
- Built-in thermal shutdown (TSD)

●Packages

SSOP-B40 13.6mm x 7.80mm x 1.80mm

●Applications

- Air conditioner blower motor
- Battery cooling fan motor
- Seat cooling fan motor

●Typical Application Circuits

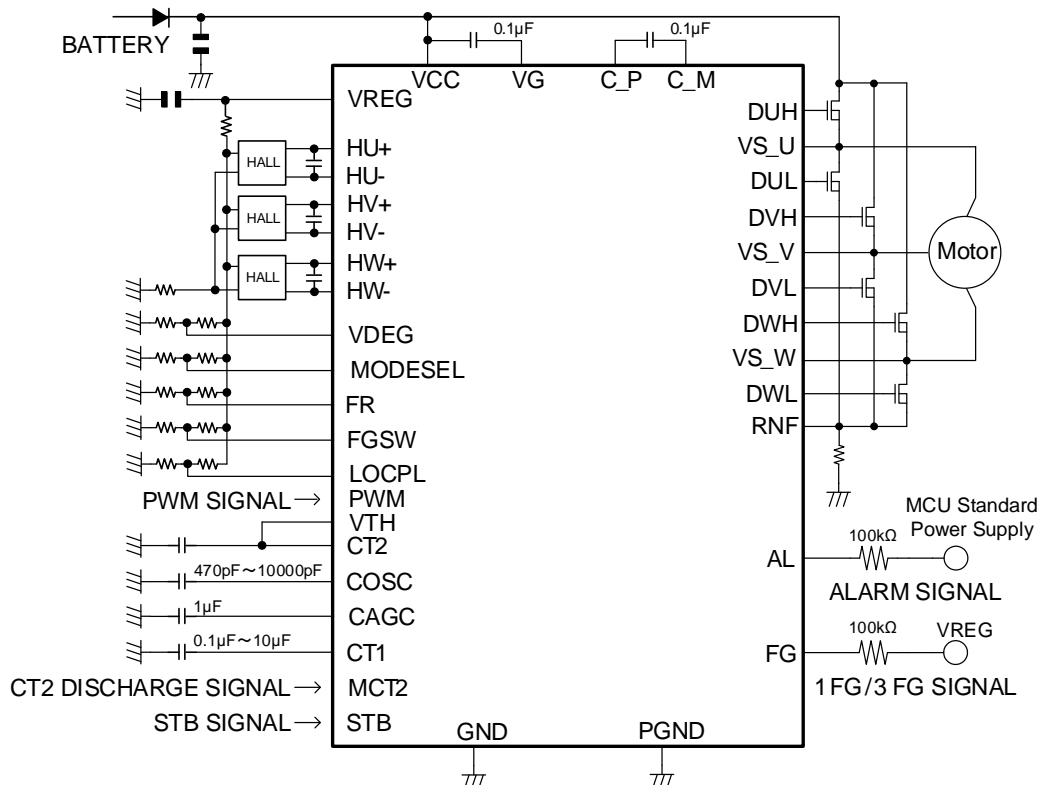

○Product structure : Silicon monolithic integrated circuit ○This product is not designed protection against radioactive rays.

●Absolute Maximum Ratings (Ta=25°C)

Parameter	Symbol	Limits	Unit
Power supply voltage	VCC	60	V
Input voltage 1	STB	7	V
Input voltage 2	PWM / FR / MODESEL / VDEG / FGSW / VTH / MCT2	VREG+0.7	V
Output voltage	D*H / VS_U / VS_V / VS_W	60	V
	D*L	15	V
	FG/AL	7	V
Power dissipation	Pd	1.125	W
Operating temperature range	Topr	-40~+110	°C
Storage temperature range	Tstg	-55~+150	°C
Joint part temperature	Tjmax	150	°C

●Recommended Operating Conditions (Ta=-40°C~+110°C)

Parameter	Symbol	Limits	Unit
Power supply voltage range of operation	VCC	8~18	V

Exceed neither Pd nor ASO.
 ROHM standard board (70mm x 70mm x 1.6mm, glass epoxy standard board)
 Reduce by 9.0mW/°C at Ta ≥ 25°C

●Block Diagram

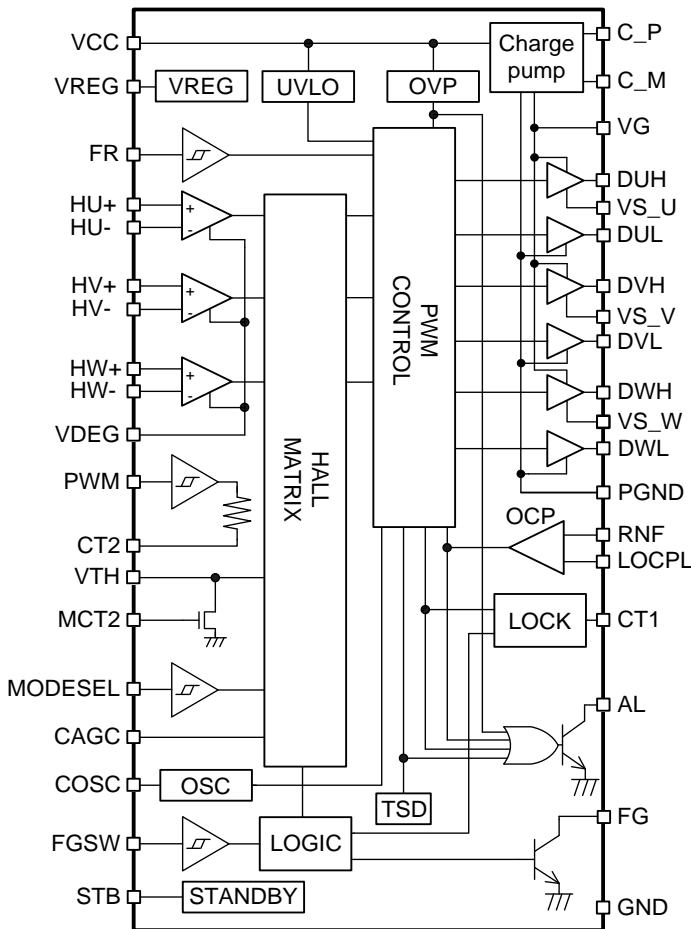

●Power Dissipation

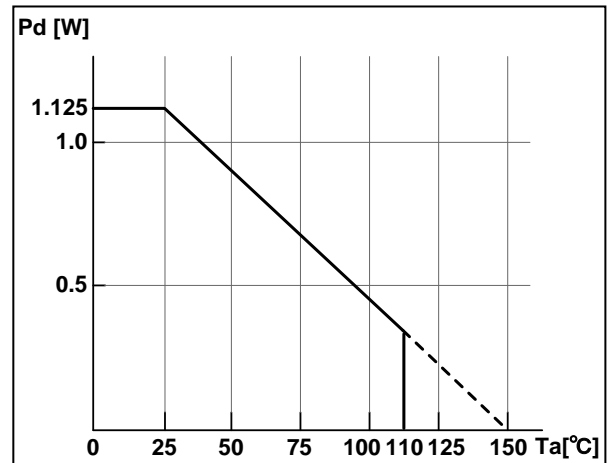

ROHM standard board (70mm x 70mm x 1.6mm, glass epoxy standard board)
 Reduce by 9.0mW/°C at Ta ≥ 25°C

●Package Dimensions

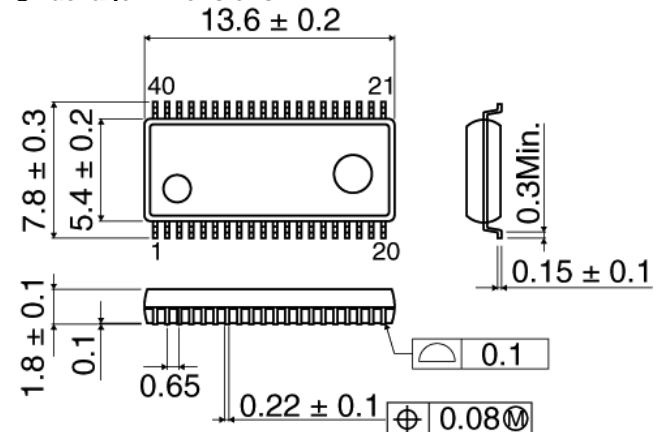

● Pin Description

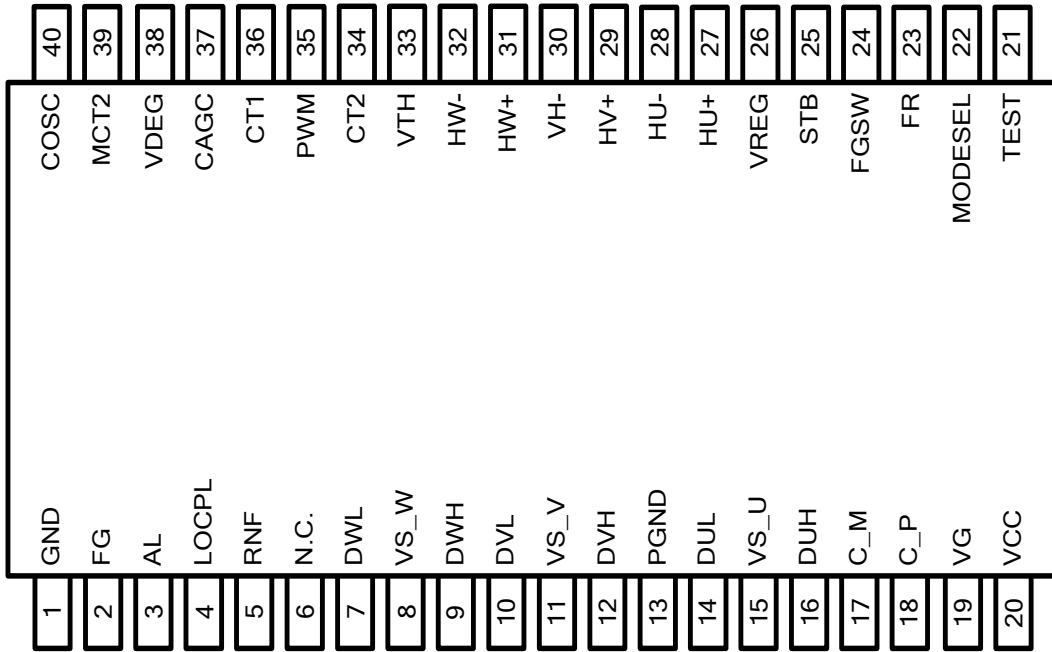

No.	Symbol	Description	No.	Symbol	Description
1	GND	GND terminal	21	TEST	TEST terminal
2	FG	1FG / 3FG output terminal	22	MODESEL	Output mode selection terminal
3	AL	Alarm signal output terminal	23	FR	Normal rotation/reversal rotation switch terminal
4	LOCPL	Current limit setting terminal	24	FGSW	1FG / 3FG switch terminal
5	RNF	Current detection terminal	25	STB	Stand by terminal
6	N.C.	N.C.	26	VREG	Internal standard power supply terminal
7	DWL	W phase L side FET drive output terminal	27	HU+	Hall input terminal
8	VS_W	W phase Motor output terminal	28	HU-	Hall input terminal
9	DWH	W phase H side FET drive output terminal	29	HV+	Hall input terminal
10	DVL	V phase L side FET drive output terminal	30	HV-	Hall input terminal
11	VS_V	V phase Motor output terminal	31	HW+	Hall input terminal
12	DVH	V phase H side FET drive output terminal	32	HW-	Hall input terminal
13	PGND	POWER GND terminal	33	VTH	Control input terminal(DC)
14	DUL	U phase L side FET drive output terminal	34	CT2	MUTE return and uptime setting terminal
15	VS_U	U phase Motor output terminal	35	PWM	Control input terminal(PWM)
16	DUH	U phase H side FET drive output terminal	36	CT1	Lock protection time setting terminal
17	C_M	Charge pump capacitor connection terminal-	37	CAGC	Capacitor for phase amends
18	C_P	Charge pump capacitor connection terminal +	38	VDEG	Phase adjustment control
19	VG	Predriver circuit power supply terminal	39	MCT2	CT2 connection for capacitor discharge terminal
20	VCC	Power supply terminal	40	COSC	PWM frequency setting terminal

●Ordering Information

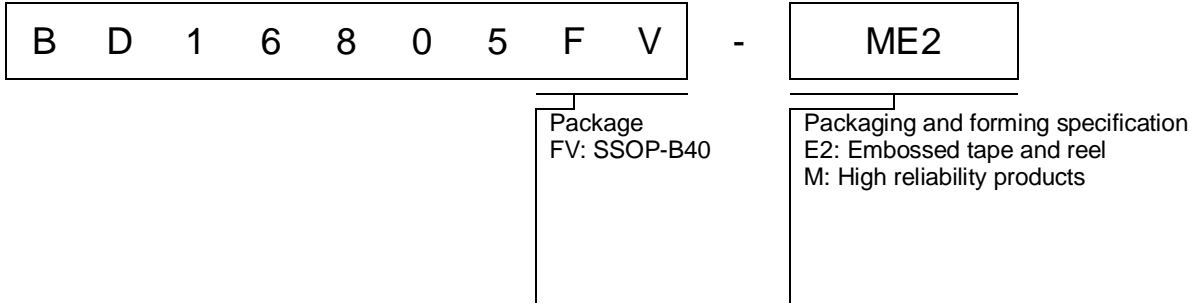

●Physical Dimension and Packing Information

SSOP-B40

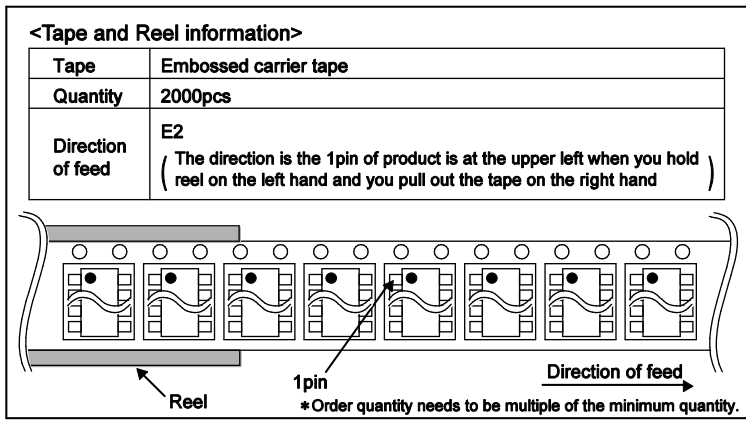
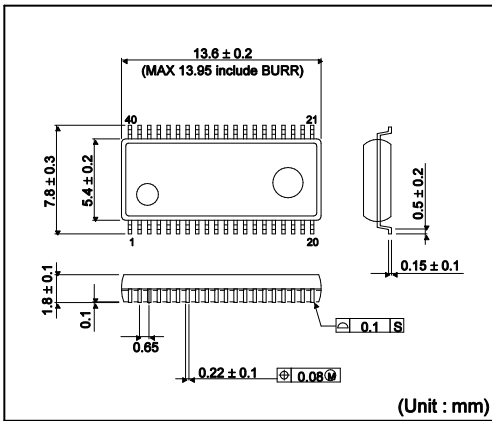

●Marking Diagram

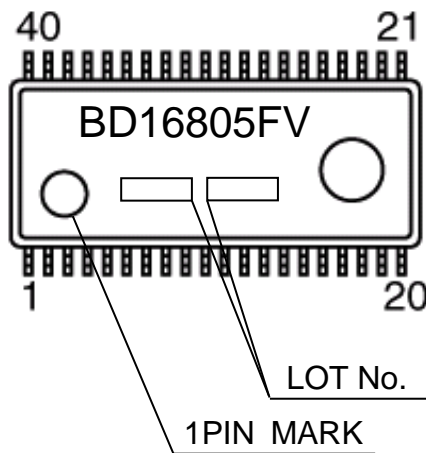

● **Electrical Characteristics**(Unless otherwise noted, VCC=8V~18V, Ta=-40°C~+110°C, Hall input amplitude=100mVpp, VEDG=2.5V, COSC=1000pF, Between C_P and C_M=0.1μF, between VG and VCC=0.1μF, CAGC=1μF, VS_U=VS_V=VS_W=GND ※1)

Parameter	Symbol	Limits			Unit	Condition
		MIN.	TYP.	MAX.		
【Whole】						
Circuit current 1	ICC1	-	0	10	μA	STB=L ※2
Circuit current 2	ICC2	-	15.2	30.4	mA	STB=H, VTH=0V VS_U,VS_V,VS_W=open
【Hall amplifier】						
Input bias current	IB	-10	0	+10	μA	
Input level	VINH	45	-	-	mVpp	Both sides input level
Range of phase input	VHAR	1.3	-	3.7	V	
【VREG terminal】						
VREG voltage	VREG	5.2	5.5	5.8	V	At -20mA SOURCE ※3
【STB terminal】						
"L" Range of level voltage	VSTBL	0	-	1.0	V	
"H" Range of level voltage	VSTBH	3.0	-	VREG	V	
Outflow current	ISTBL	-	-	10	μA	VSTB=0V
Inflow current	ISTBH	20	40	80	μA	VSTB=5V
【PWM terminal】						
"L" Range of level voltage	VPWML	0	-	1.0	V	
"H" Range of level voltage	VPWMH	3.0	-	VREG	V	
Outflow current	IPWML	-	-	10	μA	VPWM=0V
Inflow current	IPWMH	25	50	100	μA	VPWM=5V
Output resistance	RPWM	80	200	320	kΩ	
Input dead zone output ON DUTY1	ONDUTY1	9.5	12.5	15.5	%	Figure -4 reference
Input dead zone output OFF DUTY1	OFFDUTY1	4.5	7.5	10.5	%	Figure -4 reference
Input dead zone output OFF DUTY2	OFFDUTY2	95.5	97.5	99.5	%	Figure -4 reference
Input dead zone output ON DUTY2	ONDUTY2	90.5	92.5	94.5	%	Figure -4 reference
Input dead zone hysteresis width 12	DUTYHYS12	3	5	7	%	Figure -4 reference
Voltage L of torque input mask	TQML	0.5	2.5	4.5	%	VMODESEL=H Figure -8 reference
【VTH terminal】						
Predriver output DUTY1	DUTY 1	49.1	56.6	64.1	%	VTH=1.0V ※4 Figure -9 reference
Predriver output DUTY2	DUTY 2	59.2	66.7	74.2	%	VTH=2.0V ※4 Figure -9 reference
Predriver output DUTY3	DUTY 3	65.8	73.3	80.8	%	VTH=2.4V ※4 Figure -9 reference
Predriver output DUTY4	DUTY 4	75.7	83.2	90.7	%	VTH=2.9V ※4 Figure -9 reference
【VDEG terminal】						
Range of Phase adjustment control	VVDEG	27	30	33	deg	VDEG=0V
Phase adjustment control accuracy	FHDEG	-3	0	+3	deg	VDEG=2.5V

※1 VS_U, VS_V, VS_W=GND only at measuring electric characteristics. In normal operation, please connect to motor output of each phase

※2 Please set input pins (PWM pin, FR pin, MODESEL pin, VDEG pin, FGSW pin, VTH pin, MCT2 pin) to 0V

※3 Please connect to phase compensation capacitor 1μF or more between the VREG and GND.

※4 Measure output DUTY with condition of applying 2.5Vpp standard ±100mV DC to hall inputs and 2.2Vpp to COSC in Test mode.

● **Electrical Characteristics**(Unless otherwise noted, VCC=8V~18V, Ta=-40°C~+110°C, Hall input amplitude=100mVpp, VEDG=2.5V, COSC=1000pF, Between C_P and C_M=0.1μF, between VG and VCC=0.1μF, CAGC=1μF, VS_U=VS_V=VS_W=GND ※1)

Parameter	Symbol	Limits			Unit	Condition
		MIN.	TYP.	MAX.		
【COSC terminal】						
OSC frequency	FOSC	17.5	25	32.5	kHz	COSC=1000pF ※5
【FR terminal】						
"L" Range of level voltage	VFRL	0	-	1.0	V	
"H" Range of level voltage	VFRH	3.0	-	VREG	V	
Outflow current	IFRL	-	-	10	μA	VFR=0V
Inflow current	IFRH	25	50	100	μA	VFR=5V
【FGSW terminal】						
1FG Range of level voltage	VFG1L	0	-	1.0	V	
3FG Range of level voltage	VFG3H	3.0	-	VREG	V	
Outflow current	IFG1L	-	-	10	μA	VFGSW=0V
Inflow current	IFG3H	25	50	100	μA	VFGSW=5V
【MODESEL terminal】						
"L" Range of level voltage	VMODEL	0	-	1.0	V	
"H" Range of level voltage	VMODEH	3.0	-	VREG	V	
Outflow current	IMODEL	-	-	10	μA	VMODESEL=0V
Inflow current	IMODEH	25	50	100	μA	VMODESEL=5V
【AL terminal】						
"L" Range of level voltage	VALL	0	-	0.3	V	AL=5V input (PULL UP100kΩ)
"H" Range of level voltage	VALH	4.8	5	-	V	AL=5V input (PULL UP100kΩ)
【FG terminal】						
"L" Range of level voltage	VFGL	0	-	0.3	V	FG=5V input (PULL UP100kΩ)
"H" Range of level voltage	VFGH	4.8	5	-	V	FG=5V input (PULL UP100kΩ)
【LOCPL terminal】						
Overcurrent detection COMP offset	VOCP OFFSET	-10	-	+10	mV	LOCPL=20mV, 200mV
OCP MUTE delay time	OCPMUTET ₀	-	-	20	μs	
OCP release delay time	OCPMUTET ₁	15	36	65	μs	
【CT1 terminal】						
SOURCE current for lock protection detection	ILOCK	0.5	1	1.5	μA	Figure-3 reference
CT1 SW ON resistance for Discharge	RONCT1	-	81	320	Ω	Figure-3 reference
CT1 Leakage at SW OFF for Discharge	ILEAKCT1	-	0	1	μA	Figure-3 reference
CT1 Comparison H Voltage	VLOCKP_H	3.40	3.85	4.30	V	
CT1 Comparison L Voltage	VLOCKP_L	0.45	0.55	0.65	V	

※5 Please use COSC within the range of 470pF-10000pF.

● **Electrical Characteristics**(Unless otherwise noted, VCC=8V~18V, Ta=-40°C~+110°C, Hall input amplitude=100mVpp, VEDG=2.5V, COSC=1000pF, Between C_P and C_M=0.1μF, between VG and VCC=0.1μF, CAGC=1μF, VS_U=VS_V=VS_W=GND ※1)

Parameter	Symbol	Limits			Unit	Condition
		MIN.	TYP.	MAX.		
【MCT2 terminal】						
"L" Range of level voltage	VMCT2L	0	-	1.0	V	
"H" Range of level voltage	VMCT2H	3.0	-	VREG	V	
Inflow current	IMCT2L	-	-	10	μA	VMCT2=0V
Outflow current	IMCT2H	25	50	100	μA	VMCT2=5V
CT2 STBY SW ON resistance for Discharge	RONCT2	-	105	260	Ω	VMCT2=5V
CT2 Leakage at SW OFF for Discharge	ILEAKCT2	-	0	1	μA	
【VG terminal】						
Pressure voltage 1	VG1	2xVCC -15	2xVCC -05	2xVCC +05	V	VCC=8V~11.5V
Pressure voltage 2	VG2	VCC +10	VCC +11.5	VCC +13	V	VCC=11.5V~18V
Pressure voltage 3	VG3	-	0.6	1.0	V	VG drop voltage at -5mA SOURCE
【Predriver output terminal】						
D*H H voltage1	VOHH1	23	-	31	V	VCC=18V ※6
D*H L voltage1	VOHL1	-	0	0.2	V	VCC=18V ※6
D*L H voltage1	VOLH1	10	-	13	V	VCC=18V ※6
D*L L voltage1	VOLL1	-	0	0.2	V	VCC=18V ※6
D*H H voltage2	VOHH2	13.5	-	16.5	V	VCC=8V ※6
D*H L voltage2	VOHL2	-	0	0.2	V	VCC=8V ※6
D*L H voltage2	VOLH2	7.5	-	8.5	V	VCC=8V ※6
D*L L voltage2	VOLL2	-	0	0.2	V	VCC=8V ※6
D*H Standing up slew rate 1	VOHUSR1	14	-	55	V/μs	VCC=18V ※6
D*H Standing fall slew rate 1	VOHDSR1	30	-	120	V/μs	VCC=18V ※6
D*L Standing up slew rate 1	VOLUSR1	14	-	60	V/μs	VCC=18V ※6
D*L Standing fall slew rate 1	VOLDSR1	20	-	85	V/μs	VCC=18V ※6
D*H Standing up slew rate 2	VOHUSR2	14	-	45	V/μs	VCC=8V ※6
D*H Standing fall slew rate 2	VOHDSR2	14	-	70	V/μs	VCC=8V ※6
D*L Standing up slew rate 2	VOLUSR2	14	-	50	V/μs	VCC=8V ※6
D*L Standing fall slew rate 2	VOLDSR2	14	-	55	V/μs	VCC=8V ※6
D*H D*L Dead Time(Standing up)	TDEAD	0.30	0.95	3.00	μs	
【Others】						
Over voltage detection	VOVP	25	30	35	V	
Under voltage detection	VUVLO	5.3	5.8	6.3	V	

※6 Measure when the capacitor of 10000pF is connected with the output as external MOS-FET gate capacitance.

●Timing Chart

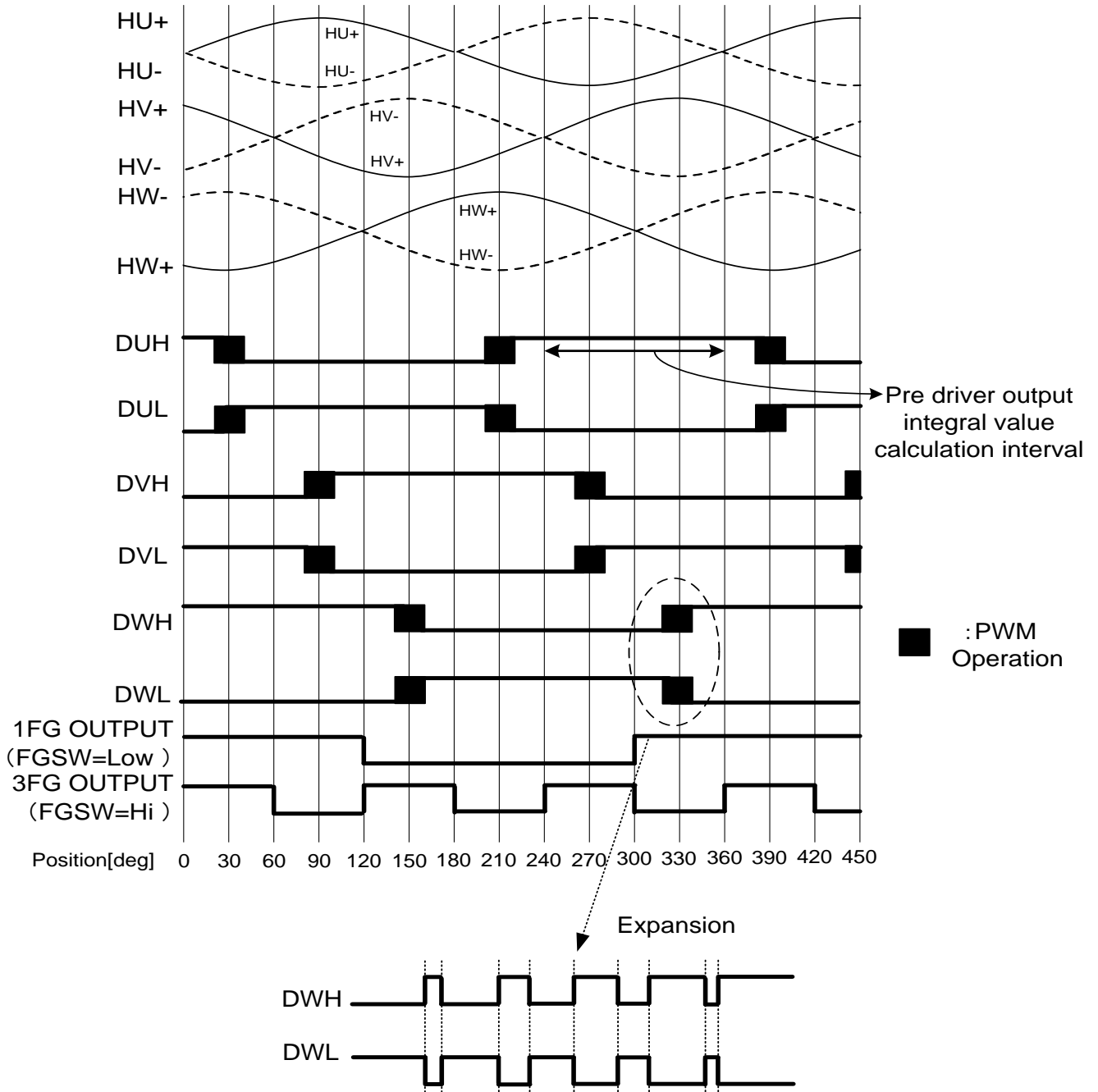

Figure -1(a) Timing chart (FR=L : Forward)

●Timing Chart - continued

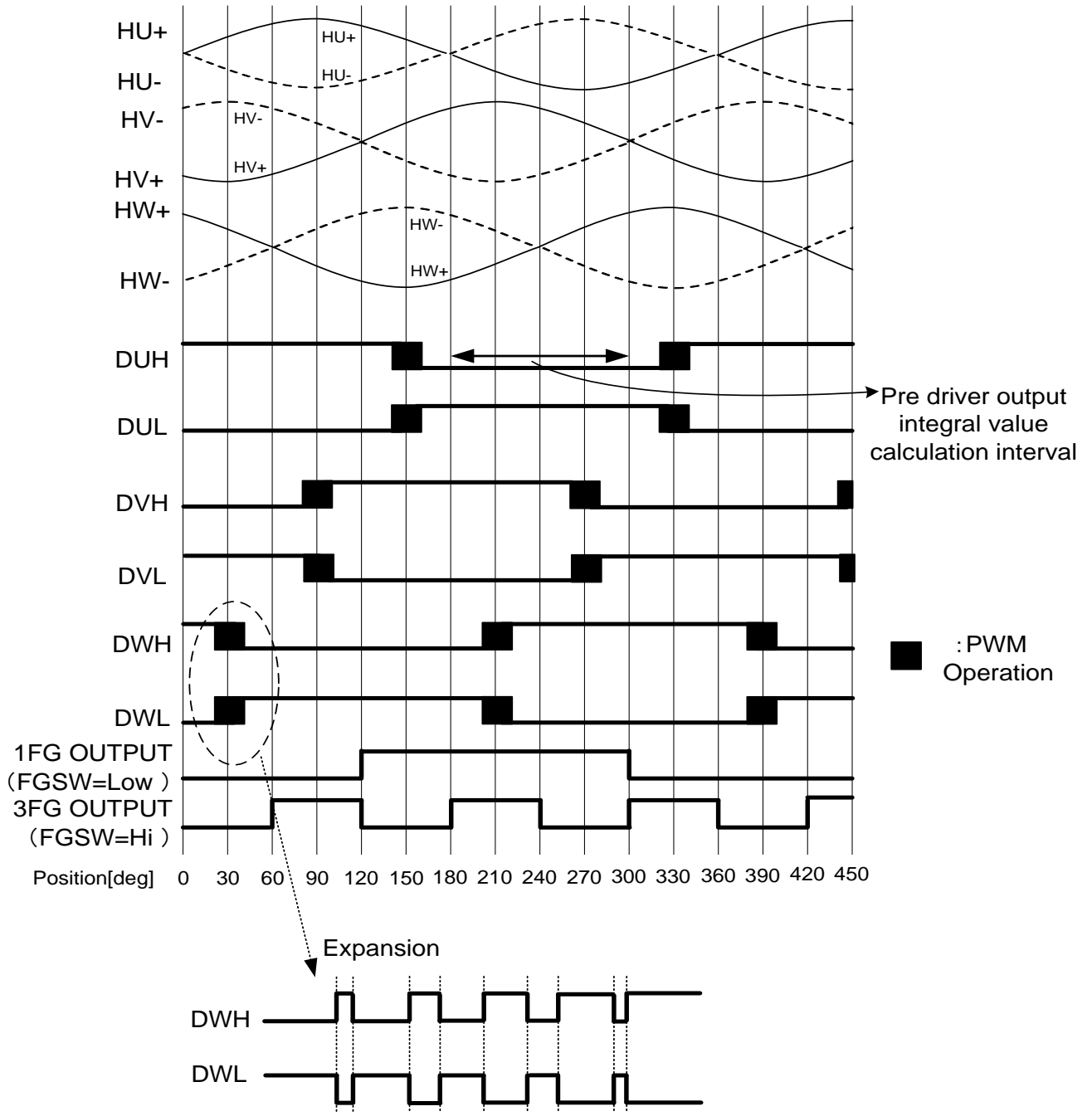

Figure -1(b) Timing chart (FR=H : Reverse)

●Operation Explanation

1. The state of the output at each MUTE

Protection mode	AL (Alarm signal)	Predriver output (D*H)	Predriver output (D*L)	Charge pump output
Over current protection	Low	Low	Low	ACTIVE
Lock protection	Low	Low	Low	ACTIVE
Under voltage protection	Hi	Low	Low	ACTIVE
Over voltage protection	Low	Low	Low	MUTE
Thermal shutdown	Low	Low	Low	ACTIVE

2. Current limit (overcurrent protection circuit)

Current limit current I is decided by the resistance setting of LOCPL and the RNF current detection terminal. A current limit operates by the value decided as shown in the figure below by the following calculation types. Please use the setting range of LOCPL with 20mV-200mV. Please use it noting S/N when setting LOCPL by a low value.

$$I = V1 / RNF$$

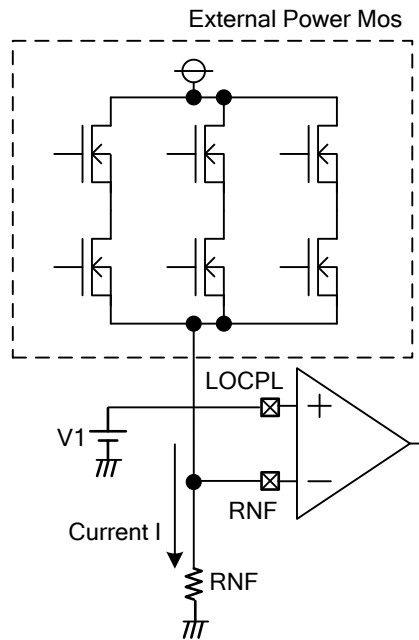

Figure -2(a) Overcurrent limit equivalent circuit diagram

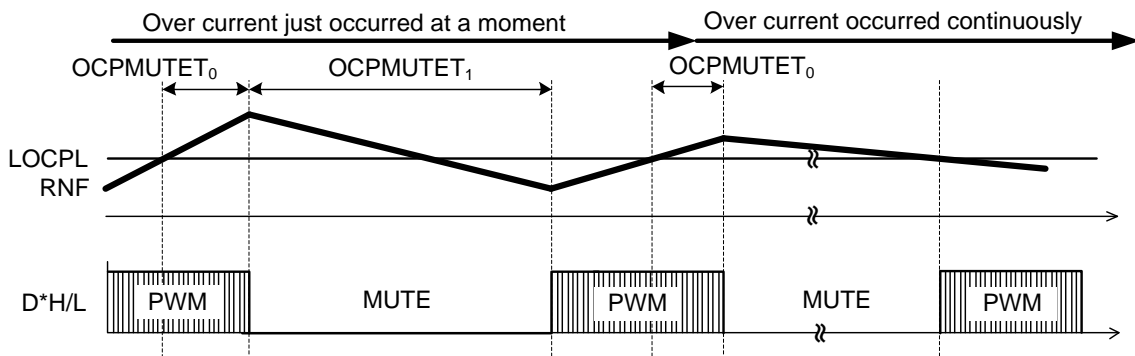

Figure -2(b) Overcurrent Protection Timing chart

●Operation Explanation - continued

3. Lock protection function

If hall input signal is stop, the lock protection circuit is determined that detection of lock protection. When the lock protection circuit is detect lock protection, all predriver output is fix to Low.

Terminal CT1 capacitor and lock protection ON time (TON1)
 $TON1(\text{Charging time}) = (V_{\text{LOCKP_H}} - V_{\text{LOCKP_L}}) / (I_{\text{LOCK}}/C)$

C : CT1 Capacity of terminal external capacitor
 ILOCK : SOURCE current for lock protection detection (TYP.:1μA)
 VLOCKP_H : Terminal CT1 comparison H voltage (TYP.:3.85V)
 VLOCKP_L : Terminal CT1 comparison L voltage (TYP.:0.55V)
 Reference value (example)

At CT1=1μF
 $TON1 = (3.85 - 0.55)V / (1\mu A / 1\mu F) = 3.3s$
 At CT1=10μF
 $TON1 = (3.85 - 0.55)V / (1\mu A / 10\mu F) = 33s$

Our company is recommending the range of 0.1μF-10μF to the capacitor of CT1.
 CT1 is shorted to GND when the lock protection time is not set.

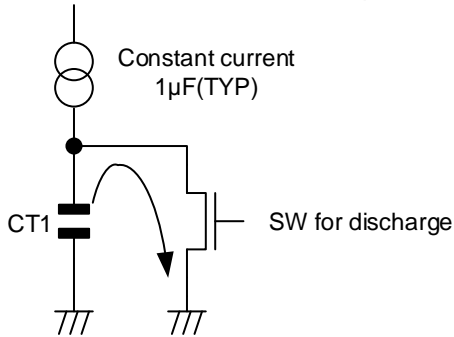

Figure -3 CT1 Charge Discharge equivalent circuit chart

When the lock protection is released and it reactivates, the CT1 capacitor should be completely discharged. Discharge SW of Figure-3 is turned on to integral value 47.7% as shown in Figure-7, 8. Please raise PWM input DUTY after discharging the CT1 capacitor.

(Reference)

The discharge time is decided by the expression of $\Delta V = (1 - e^{-t/(C \times R)}) \times \Delta V(\text{initial value})$.

At $t = C \times R$, it becomes the standing fall time of 63.2%.

ON resistance of SW for CT1 discharge becomes MAX.=320Ω.

(Refer to electric characteristic CT1 terminal item P.6.)

4. Over power supply voltage output OFF function

Over power supply voltage output OFF function is built into as output protection at the over voltage. When the impressed voltage to the terminal VCC becomes 30V (TYP.) or more, all Predriver output terminal becomes Low. However, it is only STB=Hi as the operation condition. Please note that this function doesn't operate because the current supply also stop in IC at STB=Low (At the standby).

Over power supply voltage output OFF function is built into. Please do not exceed the absolute maximum rating so that there is a possibility of destruction when the absolute maximum rating of the power supply voltage is exceeded.

●Operation Explanation - continued

5. Torque input instruction <PWM input DUTY • VTH(DC input)>
 This circuit compares OSC (triangular wave) and the voltage proportional to torque.

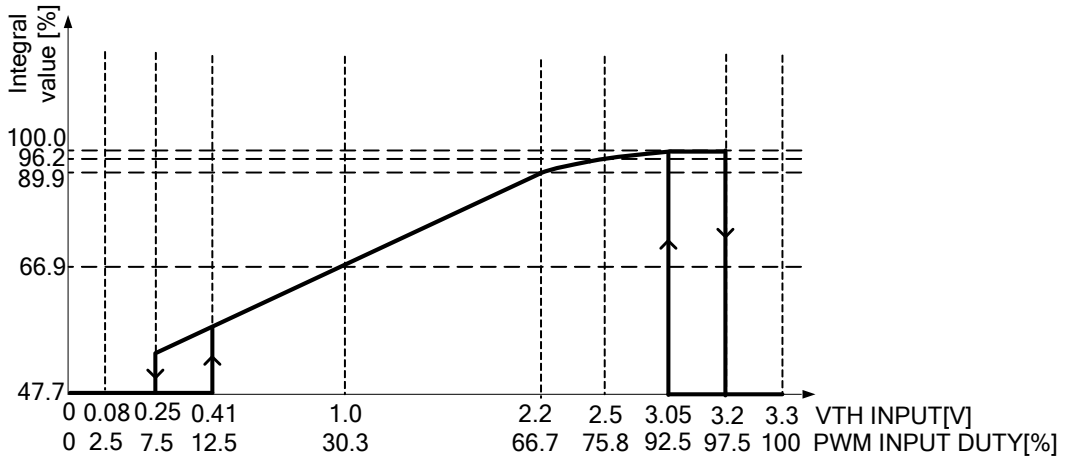

Figure -4 PWM INPUT DUTY, VTH(DC INPUT) vs OUTPUT DUTY (MODESEL=L)

Integral value in Figure-4 is measured in 120°interval (please refer to Figure-1(a), (b))
 Hysteresis has been installed in PWM input DUTY (VTH input). 12.5%(0.41V) (TYP.) > is PWM DUTY of standing up in the lower side, and 7.5%(0.25V) (TYP.) is PWM DUTY of the standing fall.
 97.5%(3.2V) (TYP.) is PWM DUTY of the standing fall in the upper side, and 92.5%(3.05V) (TYP.) is PWM DUTY of standing up. PWM input DUTY (VTH input) can control the torque output voltage by 12.5%-97.5% torque output voltage at MODESEL=HI.
 It becomes similar set about 12.5%-97.5% torque output voltage at MODESEL=HI.
 OSC (triangular wave) and the voltage proportional to torque are compared by 2.5V standard. Figure-5 becomes the torque output voltages and shape of waves of triangular wave when VTH=2.5V is input.
 The amplitude of the torque output voltage compared with a triangular wave changes when VTH is changed such as Figure-4.

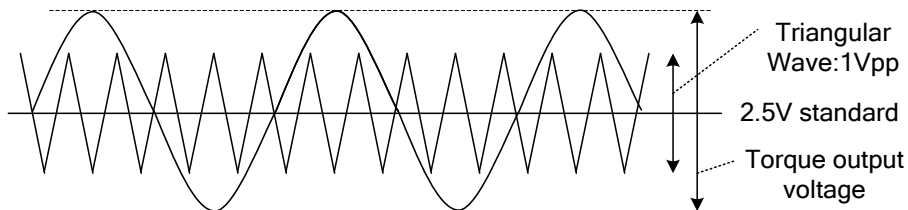

Figure -5 OCS (Triangular wave) and TORQUE OUTPUT VOLTAGE

(Using the PWM or DC input)
 The capacitor is connected with CT2 and be short-circuited with the terminal VTH and use it when using PWM input DUTY control. Please impress the input to VTH and control when using VTH(DC input) control.
 Please install the R-C filter by external when installing the start delay. When DC and PWM are input, it is possible to discharge of the capacitor in the terminal MCT2.

6. OSC (PWM oscillation frequency)
 The oscillation frequency can be arbitrarily set with an external capacitor (terminal COSC). The theoretical formula of the oscillation frequency is as follows.

$$\text{Oscillation frequency [Hz]} = 1 / (\text{COSC}/25\mu\text{A})$$

Please use the range where external capacitor (COSC) can be set with 470pF-10000pF.

● Operation Explanation - continued

7. Start time and the deceleration time (brake)

When making it to ACTIVE(STB=Hi) from the standby(STB=Low), start time can be given to the output. The time of the deceleration (brake) operates the same time as a start time.

The start return time and the deceleration time are indicated in Figure-6.

Because the start return time is decided CT2 external capacitor and internal resistance of IC, it is possible to adjust it with CT2 external capacitor.

(The following Refer to the expression of start and deceleration time)

(Reference) Terminal CT2 capacitor, start time, and deceleration time (TON2) are

$$TON2=C \times R$$

C : Capacity of terminal CT2 external capacitor

R : Internal resistance of IC (TYP. : 200kΩ)

Reference value (Example)

At CT2=1μF,

$$TON2=1\mu F \times 200k\Omega=0.2s$$

At CT2=10μF,

$$TON2=10\mu F \times 200k\Omega=2.0s$$

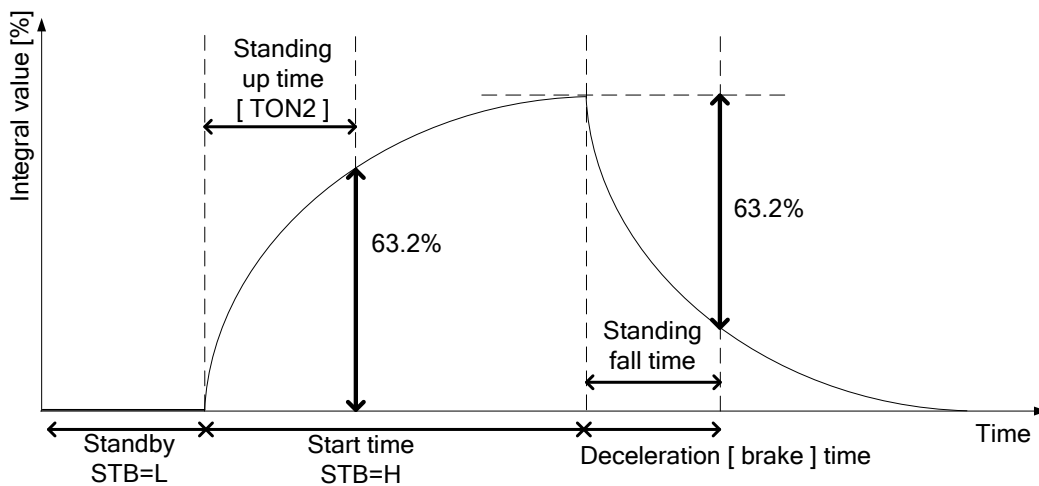

Figure -6 Start time • Deceleration (brake) timing chart

A set value of CT2 holds PWM smooth input concurrently.

The shake accuracy after smoothness influences output DUTY accuracy. Please confirm the DUTY change and set the optimal value.

The smoothness of PWM is recommended to set the cutoff frequency by 1/10 or less of the PWM input frequencies.

Please consult once when the PWM input frequency is used excluding the above-mentioned regulations.

(Reference)

$$f_c (\text{cutoff frequency}) = 1 / (2\pi CR)$$

R : TYP. : 200kΩ by internal resistance of IC (RPWM)

C : Capacity of terminal CT2 external capacitor

When making it to ACTIVE(STB=Hi) from the standby(STB=Low), the CT2 capacitor should be completely discharged. Please fix the PWM input to DUTY 0% and discharge it by 200kΩ(TYP.) resistance or please make to SW=HI(MCT2=5V) (ON resistance MAX.=260Ω) for MCT2 discharge for the discharge of the CT2 capacitor (Figure-4).

●Operation Explanation - continued

8. Output mode selection

The output mode form becomes and two following selections become possible by the voltage of the terminal MODESEL is impressed to L(0V - 1.0V) and H(3.0V - VREG).

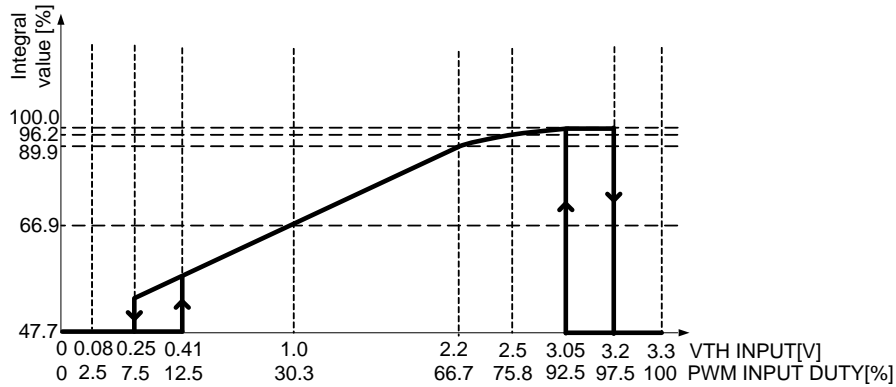

Figure -7 PWM input DUTY (VTH input) vs OUTPUT DUTY (MODESEL=L)

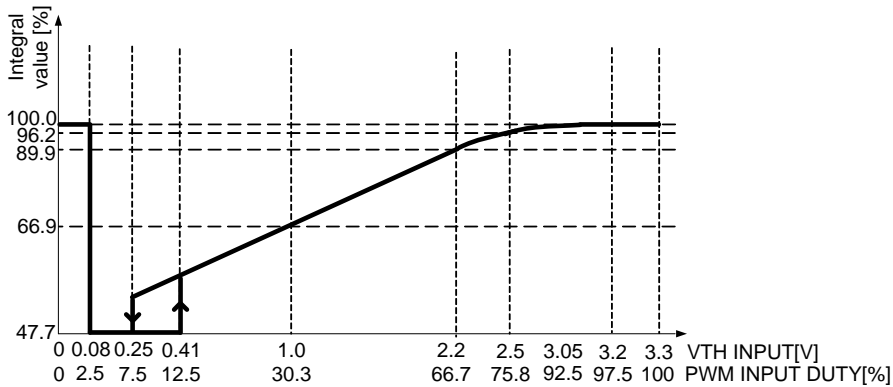

Figure -8 PWM input DUTY (VTH input) vs OUTPUT DUTY (MODESEL=H)

9. TEST terminal

It is a test terminal among our company and please fix TEST terminal to Low.

10. External constant

Our company designs within the range of an external constant described in application circuit diagram.

Please consult our company once though there is a thing that the characteristic cannot guarantee, when the change is necessary.

11. Predriver Output DUTY

Predriver Output DUTY is measured in Test mode.

Peak voltage of torque output at VTH=1V, 2V, 2.4V and 2.9V is shown at ①~④ in Figure-9 in measurement of predriver output DUTY. For measuring predriver output DUTY, hall input is applied with DC voltage considerably to torque peak voltage of ①~④ (hall input amplitude is assumed as 100mVpp). In this condition, torque output voltage is shown in Figure-9 as ①'~④'. In addition, triangular waveform amplitude of COSC becomes 2.2Vpp. DUTY of predriver output is measured by comparison of voltage of ①'~④' and triangular waveform 2.2Vpp

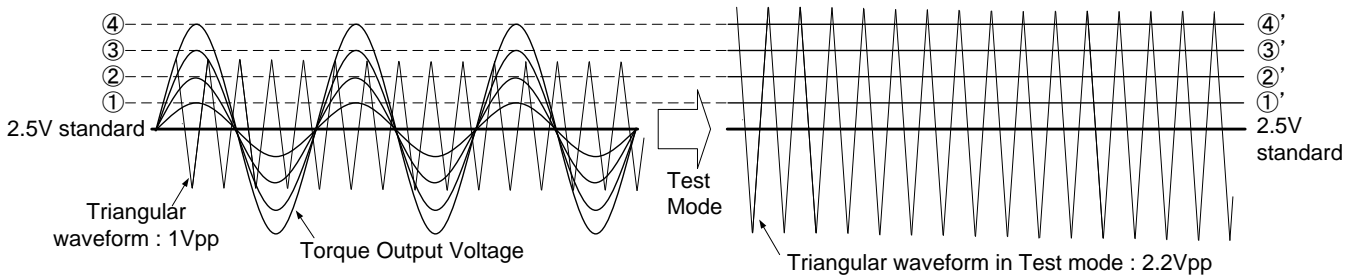

Figure -9 PREDRIVER OUTPUT DUTY Measure method

●Operational Notes

- 1) We are careful enough for quality control about this IC. So, there is no problem under normal operation, excluding that it exceeds the absolute maximum ratings. However, this IC might be destroyed when the absolute maximum ratings, such as impressed voltages (VCC) or the operating temperature range, is exceeded, and whether the destruction is short circuit mode or open circuit mode cannot be specified. Please take into consideration the physical countermeasures for safety, such as fusing, if a particular mode that exceeds the absolute maximum rating is assumed.
- 2) GND line
The ground line is where the lowest potential and transient voltages are connected to the IC.
- 3) Input terminal
Please do not add the voltage to each input terminal when you do not impress VCC to IC.
- 4) BEMF
BEMF might be changed depending on use conditions and an individual characteristic of the environment and the motor. Please confirm there is no problem in the operation of IC by BEMF.
- 5) VCC
Please put coupling capacitor 10 μ F or more in the power supply between the power supply and GND.
- 6) Power dissipation
Power dissipation is changed by the state of the substrate mounting and the mounting environment of IC, and take care enough about the heat design.
- 7) Power consumption
Power consumption changes greatly depending on the power-supply voltage and the output current. Please design heat after considering the thermal resistance data and the transition thermal resistance data, etc. to consider power dissipation, and so as not to exceed ratings.
- 8) ASO
Please set not to exceed ASO (area of safe operation) the output current and the power-supply voltage.
- 9) The circuit that limits the inrush current is not built into this IC. Therefore, please consider physical measures of putting the current limitation resistance.
- 10) There is a possibility that the trouble of the malfunction occurs if the potential of the output terminal widely swings to the potential of GND or less in this IC according to conditions such as the generation of heat condition, power-supply voltages, and the use motors. For that case, please consider measures where trouble doesn't occur as shot key diode is added between GND-output.
- 11) Radiation
This IC doesn't do the design that assumes use in strong electromagnetic field. Please confirm there is no problem in the operation of IC by the substrate pattern layout and the circuit constant enough.
- 12) Thermal shutdown
The thermal shutdown circuit is built into as an overheating protection measures this IC. When the Chip temperature of IC becomes 175°C (TYP.) or more, the output is opened. It returns to normal operation when becoming 150°C (TYP.) or less.
- 13) FG output signal
When the noise is generated in the hall signal, the FG signal might do chattering. Especially, the possibility that chattering is caused as the power-supply voltage touches rises when rapidly changing from the normal rotation into the reversal rotation or from the reversal rotation into the normal rotation. CAPA is inserted between the hall input terminals to decrease the noise of the hall signal, and the attention such as enlarging the input level is necessary when using it like this.

●Operational Notes - continued

14) Wrong direction assembly of the device.

Use caution when positioning the IC for mounting on printed circuit boards. The IC may be damaged if there is any connection error.

15) Regarding input pin of the IC I

This monolithic IC contains P+ isolation and P substrate layers between adjacent elements to keep them isolated. PN junctions are formed at the intersection of these P layers with the N layers of other elements, creating a parasitic diode or transistor. For example, the relation between each potential is as follows:

When $GND > Pin A$ and $GND > Pin B$, the PN junction operates as a parasitic diode.

When $Pin B > GND > Pin A$, the PN junction operates as a parasitic transistor.

Parasitic diodes can occur inevitably in the structure of the IC. The operation of parasitic diodes can result in mutual interference among circuits, operational faults, or physical damage. Accordingly, methods by which parasitic diodes operate, such as applying a voltage that is lower than the GND (P substrate) voltage to an input pin, should not be used

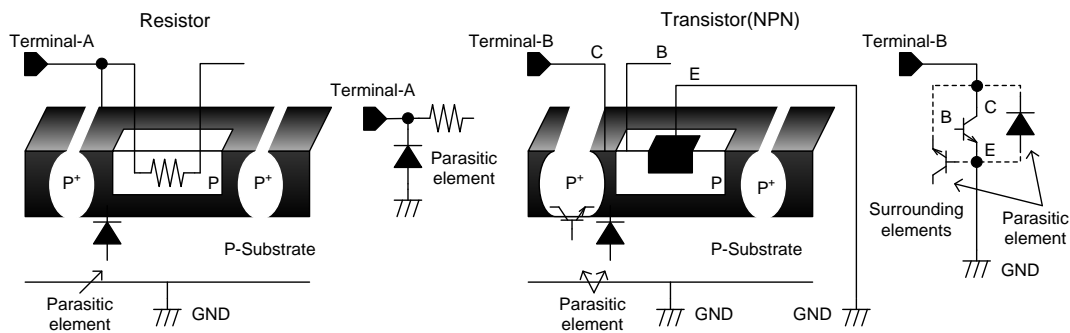

Figure -10 Simplified structure of IC

Status of this document

The Japanese version of this document is formal specification. A customer may use this translation version only for a reference to help reading the formal version.

If there are any differences in translation version of this document formal version takes priority.

●Revision History

Date	Revision	Changes
24.Jan.2012	001	New Release
06.Oct.2016	004	Change point for Rev.003 to Rev.004
		p.1 Features Change function name. "low voltage" to "under voltage" Change function name. "overvoltage" to "over voltage"
		p.5 ※4 Correction of mistake. "... and 2.5Vpp to ..." to "...and 2.2Vpp to ..."
		p.6 【LOCPL terminal】 Change symbol. "CPMUTET ₀ " to "OCPMUTET ₀ " Change symbol. "OCPMUTET" to "OCPMUTET ₁ "
		p.7 【Others】 Change item name. "Off voltage at overvoltage" to "Over voltage detection" Change item name. "Off voltage at reduce voltage" to "Under voltage detection"
		p.10 Figure-2(b) Change waveform name. "D*H/L MUTE" to "D*H/L" Change waveform name. "(Blank)" to "MUTE"
		p.11 3. Lock protection function Change symbol. "ILOCK2" to "ILOCK" Change sentence.
		p.11 4. Over power supply voltage output OFF function Change words. "Overpower-supply" to "Over power supply" Change words. "overvoltage" to "over voltage" Change words. "power-supply" to "power supply"
		p.12 6. OSC (PWM oscillation frequency) Change unit. "Oscillation frequency [kHz]" to "Oscillation frequency [Hz]"
		p.14 11. Predriver Output DUTY Change figure name. "Figure-9(a)" to "Figure-9" Change figure name. "Figure-9 (b)" to "Figure-9"
25.Jan.2019	005	All pages Unity font and paragraph.
		All pages Index New Release
		p.2, 5, 6, 7 Range notation Add symbol. "-xx~xx" to "-xx~+xx"
		p.11, 12, 13, 14, 16 Item name Add item name for cross the page.
		p.8, 9 Item name Add item name. "(Blank)" to "●Timing Chart"
		p.2 Recommended Operating Conditions Correction of mistake. "(Ta=25°C)" to "(Ta=-40°C~+110°C)"
		p.2 Power Dissipation Correction of mistake. "Power Dissipaton" to "Power Dissipation"
		p.3 Terminal name Change format.
		p.4 Ordering Information Change format.
		p.11 3. Lock protection function Correction of mistake. "...integral value 50% as..." to "...integral value 47.7% as..." Correction of mistake. "...terminal item P.3.)" to "...terminal item P.6.)"
		p.15 Operational Notes Change item name. "Cautions on use" to "Operational Notes"
		p.17 Revision History New Release

Notice

Precaution on using ROHM Products

1. If you intend to use our Products in devices requiring extremely high reliability (such as medical equipment ^(Note 1), aircraft/spacecraft, nuclear power controllers, etc.) and whose malfunction or failure may cause loss of human life, bodily injury or serious damage to property ("Specific Applications"), please consult with the ROHM sales representative in advance. Unless otherwise agreed in writing by ROHM in advance, ROHM shall not be in any way responsible or liable for any damages, expenses or losses incurred by you or third parties arising from the use of any ROHM's Products for Specific Applications.

(Note1) Medical Equipment Classification of the Specific Applications

JAPAN	USA	EU	CHINA
CLASS III	CLASS III	CLASS II b	CLASS III
CLASS IV		CLASS III	

2. ROHM designs and manufactures its Products subject to strict quality control system. However, semiconductor products can fail or malfunction at a certain rate. Please be sure to implement, at your own responsibilities, adequate safety measures including but not limited to fail-safe design against the physical injury, damage to any property, which a failure or malfunction of our Products may cause. The following are examples of safety measures:
 - [a] Installation of protection circuits or other protective devices to improve system safety
 - [b] Installation of redundant circuits to reduce the impact of single or multiple circuit failure
3. Our Products are not designed under any special or extraordinary environments or conditions, as exemplified below. Accordingly, ROHM shall not be in any way responsible or liable for any damages, expenses or losses arising from the use of any ROHM's Products under any special or extraordinary environments or conditions. If you intend to use our Products under any special or extraordinary environments or conditions (as exemplified below), your independent verification and confirmation of product performance, reliability, etc. prior to use, must be necessary:
 - [a] Use of our Products in any types of liquid, including water, oils, chemicals, and organic solvents
 - [b] Use of our Products outdoors or in places where the Products are exposed to direct sunlight or dust
 - [c] Use of our Products in places where the Products are exposed to sea wind or corrosive gases, including Cl₂, H₂S, NH₃, SO₂, and NO₂
 - [d] Use of our Products in places where the Products are exposed to static electricity or electromagnetic waves
 - [e] Use of our Products in proximity to heat-producing components, plastic cords, or other flammable items
 - [f] Sealing or coating our Products with resin or other coating materials
 - [g] Use of our Products without cleaning residue of flux (Exclude cases where no-clean type fluxes is used. However, recommend sufficiently about the residue.); or Washing our Products by using water or water-soluble cleaning agents for cleaning residue after soldering
 - [h] Use of the Products in places subject to dew condensation
4. The Products are not subject to radiation-proof design.
5. Please verify and confirm characteristics of the final or mounted products in using the Products.
6. In particular, if a transient load (a large amount of load applied in a short period of time, such as pulse, is applied, confirmation of performance characteristics after on-board mounting is strongly recommended. Avoid applying power exceeding normal rated power; exceeding the power rating under steady-state loading condition may negatively affect product performance and reliability.
7. De-rate Power Dissipation depending on ambient temperature. When used in sealed area, confirm that it is the use in the range that does not exceed the maximum junction temperature.
8. Confirm that operation temperature is within the specified range described in the product specification.
9. ROHM shall not be in any way responsible or liable for failure induced under deviant condition from what is defined in this document.

Precaution for Mounting / Circuit board design

1. When a highly active halogenous (chlorine, bromine, etc.) flux is used, the residue of flux may negatively affect product performance and reliability.
2. In principle, the reflow soldering method must be used on a surface-mount products, the flow soldering method must be used on a through hole mount products. If the flow soldering method is preferred on a surface-mount products, please consult with the ROHM representative in advance.

For details, please refer to ROHM Mounting specification

Precautions Regarding Application Examples and External Circuits

1. If change is made to the constant of an external circuit, please allow a sufficient margin considering variations of the characteristics of the Products and external components, including transient characteristics, as well as static characteristics.
2. You agree that application notes, reference designs, and associated data and information contained in this document are presented only as guidance for Products use. Therefore, in case you use such information, you are solely responsible for it and you must exercise your own independent verification and judgment in the use of such information contained in this document. ROHM shall not be in any way responsible or liable for any damages, expenses or losses incurred by you or third parties arising from the use of such information.

Precaution for Electrostatic

This Product is electrostatic sensitive product, which may be damaged due to electrostatic discharge. Please take proper caution in your manufacturing process and storage so that voltage exceeding the Products maximum rating will not be applied to Products. Please take special care under dry condition (e.g. Grounding of human body / equipment / solder iron, isolation from charged objects, setting of Ionizer, friction prevention and temperature / humidity control).

Precaution for Storage / Transportation

1. Product performance and soldered connections may deteriorate if the Products are stored in the places where:
 - [a] the Products are exposed to sea winds or corrosive gases, including Cl₂, H₂S, NH₃, SO₂, and NO₂
 - [b] the temperature or humidity exceeds those recommended by ROHM
 - [c] the Products are exposed to direct sunshine or condensation
 - [d] the Products are exposed to high Electrostatic
2. Even under ROHM recommended storage condition, solderability of products out of recommended storage time period may be degraded. It is strongly recommended to confirm solderability before using Products of which storage time is exceeding the recommended storage time period.
3. Store / transport cartons in the correct direction, which is indicated on a carton with a symbol. Otherwise bent leads may occur due to excessive stress applied when dropping of a carton.
4. Use Products within the specified time after opening a humidity barrier bag. Baking is required before using Products of which storage time is exceeding the recommended storage time period.

Precaution for Product Label

A two-dimensional barcode printed on ROHM Products label is for ROHM's internal use only.

Precaution for Disposition

When disposing Products please dispose them properly using an authorized industry waste company.

Precaution for Foreign Exchange and Foreign Trade act

Since concerned goods might be fallen under listed items of export control prescribed by Foreign exchange and Foreign trade act, please consult with ROHM in case of export.

Precaution Regarding Intellectual Property Rights

1. All information and data including but not limited to application example contained in this document is for reference only. ROHM does not warrant that foregoing information or data will not infringe any intellectual property rights or any other rights of any third party regarding such information or data.
2. ROHM shall not have any obligations where the claims, actions or demands arising from the combination of the Products with other articles such as components, circuits, systems or external equipment (including software).
3. No license, expressly or implied, is granted hereby under any intellectual property rights or other rights of ROHM or any third parties with respect to the Products or the information contained in this document. Provided, however, that ROHM will not assert its intellectual property rights or other rights against you or your customers to the extent necessary to manufacture or sell products containing the Products, subject to the terms and conditions herein.

Other Precaution

1. This document may not be reprinted or reproduced, in whole or in part, without prior written consent of ROHM.
2. The Products may not be disassembled, converted, modified, reproduced or otherwise changed without prior written consent of ROHM.
3. In no event shall you use in any way whatsoever the Products and the related technical information contained in the Products or this document for any military purposes, including but not limited to, the development of mass-destruction weapons.
4. The proper names of companies or products described in this document are trademarks or registered trademarks of ROHM, its affiliated companies or third parties.

General Precaution

1. Before you use our Products, you are requested to carefully read this document and fully understand its contents. ROHM shall not be in any way responsible or liable for failure, malfunction or accident arising from the use of any ROHM's Products against warning, caution or note contained in this document.
2. All information contained in this document is current as of the issuing date and subject to change without any prior notice. Before purchasing or using ROHM's Products, please confirm the latest information with a ROHM sales representative.
3. The information contained in this document is provided on an "as is" basis and ROHM does not warrant that all information contained in this document is accurate and/or error-free. ROHM shall not be in any way responsible or liable for any damages, expenses or losses incurred by you or third parties resulting from inaccuracy or errors of or concerning such information.

X-ON Electronics

Largest Supplier of Electrical and Electronic Components

Click to view similar products for [Motor/Motion/Ignition Controllers & Drivers](#) category:

Click to view products by [ROHM](#) manufacturer:

Other Similar products are found below :

[FSB50550TB2](#) [FSBF15CH60BTH](#) [MSVCPM2-63-12](#) [MSVGW45-14-2](#) [MSVGW54-14-3](#) [MSVGW54-14-5](#) [NTE7043](#) [LA6565VR-TLM-E](#)
[LB11650-E](#) [LB1837M-TLM-E](#) [LB1845DAZ-XE](#) [LC898300XA-MH](#) [SS30-TE-L-E](#) [26700](#) [LV8281VR-TLM-H](#) [BA5839FP-E2](#) [IRAM236-1067A](#) [LA6584JA-AH](#) [LB11847L-E](#) [NCV70501DW002R2G](#) [AH293-PL-B](#) [STK672-630CN-E](#) [TND315S-TL-2H](#) [FNA23060](#) [FSB50250AB](#)
[FNA41060](#) [MSVB54](#) [MSVBTC50E](#) [MSVCPM3-54-12](#) [MSVCPM3-63-12](#) [MSVCPM4-63-12](#) [MSVTA120](#) [FSB50550AB](#)
[NCV70501DW002G](#) [LC898301XA-MH](#) [LV8413GP-TE-L-E](#) [MSVGW45-14-3](#) [MSVGW45-14-4](#) [MSVGW45-14-5](#) [MSVGW54-14-4](#)
[STK984-091A-E](#) [MP6519GQ-Z](#) [LB11651-E](#) [IRSM515-025DA4](#) [LV8127T-TLM-H](#) [MC33812EKR2](#) [NCP81382MNTXG](#) [TDA21801](#)
[LB11851FA-BH](#) [NCV70627DQ001R2G](#)