

Constant Current LED Drivers

Constant Current Controller for Automotive LED Lamps

BD18345EFV-M

General Description

BD18345EFV-M is 70 V-withstanding constant current controller for automotive LED lamps. It is able to drive at maximum 10 rows of PNP transistors. It can also contribute to reduction in the consumption power of the set as it has the built-in standby function. The IC provides high reliability because it has two Current de-rating function, LED open detection, short circuit protection, over voltage mute function and LED failure input/output function.

Features

- AEC-Q100 Qualified^(Note 1)
 - PWM Dimming Function
 - PWM Signal Output
 - LED Current DC Dimming
 - Thermal De-rating Function
 - LED Open Detection
 - Short Circuit Protection (SCP)
 - Over Voltage Mute Function (OVM)
 - Disable LED Open Detection Function at Reduced-Voltage
 - LED Failure Input/Output Functions (PBUS)
- (Note 1) Grade1*

Applications

- Automotive LED Exterior Lamp
(Rear Lamp, Turn Lamp, DRL/Position Lamp, Fog Lamp etc.)
- Automotive LED Interior Lamp
(Air Conditioner Lamp, Interior Lamp, Cluster Light etc.)

Typical Application Circuit

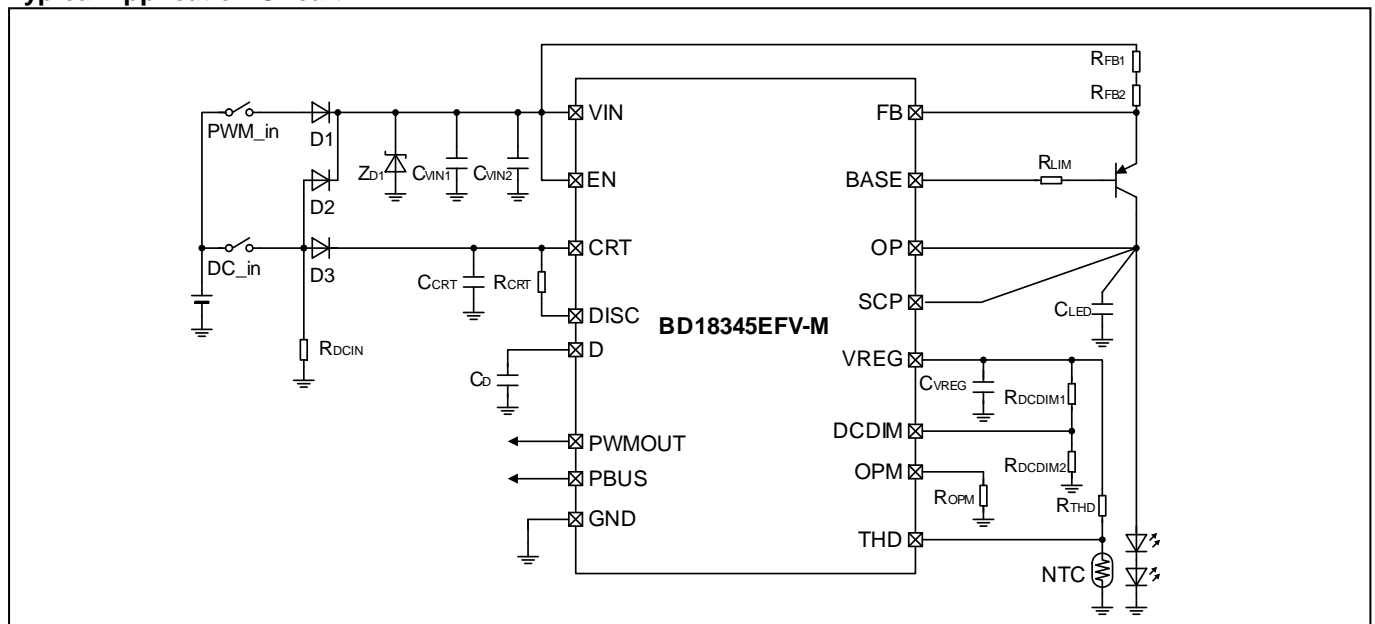

Key Specifications

- Input Voltage Range: 4.5 V to 19.0 V
- FB Pin Voltage Accuracy: 650 mV ±3 %
@Ta=25 °C to 125 °C
- Stand-by Current: 0 μA (Typ)
- LED Current De-rating Accuracy:
DCDIM Pin : ±3 % @V_{DCDIM}=0.75 V to 2.00 V
THD Pin : ±6 % @V_{THD}=0.50 V to 0.75 V
- Operating Temperature Range: -40 °C to +125 °C

Package

HTSSOP-B20

W (Typ) x D (Typ) x H (Max)

6.50 mm x 6.40 mm x 1.00 mm

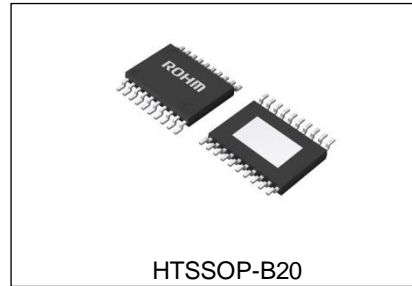

○Product structure : Silicon integrated circuit ○This product has no designed protection against radioactive rays

Pin Configuration

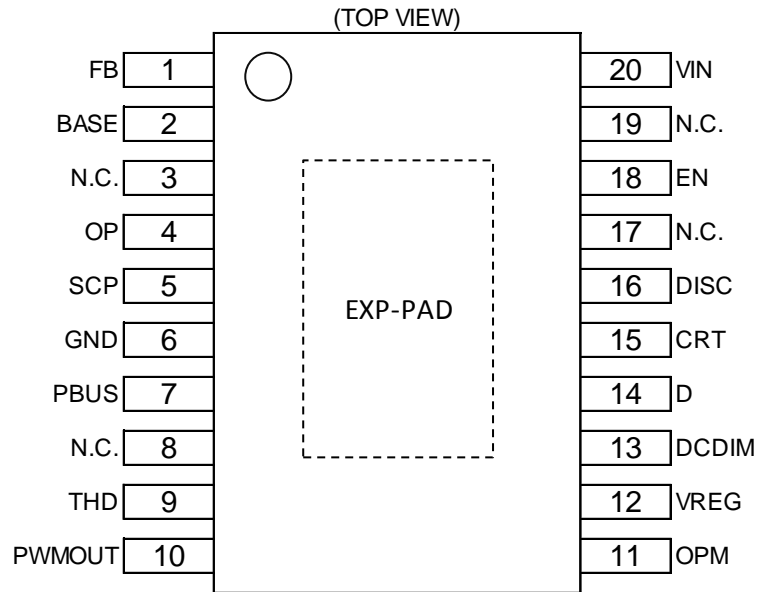

Pin Description

Pin No.	Pin Name	Function
1	FB	Feedback voltage input
2	BASE	Connecting PNP Tr. BASE
3	N.C.	No internal connection ^(Note 1)
4	OP	LED open detection input
5	SCP	Short circuit protection input
6	GND	GND
7	PBUS	Output for fault flag / Input to disable output current
8	N.C.	No internal connection ^(Note 1)
9	THD	Connecting resistor for thermal de-rating setting
10	PWMOUT	PWM signal output
11	OPM	Connecting resistor for disable LED open detection voltage setting at reduced voltage
12	VREG	Internal reference voltage output
13	DCDIM	Connecting resistor for DC dimming setting
14	D	Connecting capacitor for disable LED open detection time setting
15	CRT	Connect capacitor and resistor to set output current ON Duty
16	DISC	Connecting resistor to set output current on time
17	N.C.	No internal connection ^(Note 1)
18	EN	Enable input
19	N.C.	No internal connection ^(Note 1)
20	VIN	Power supply input
-	EXP-PAD	The EXP-PAD connect to GND.

(Note 1) Leave this pin unconnected

Block Diagram

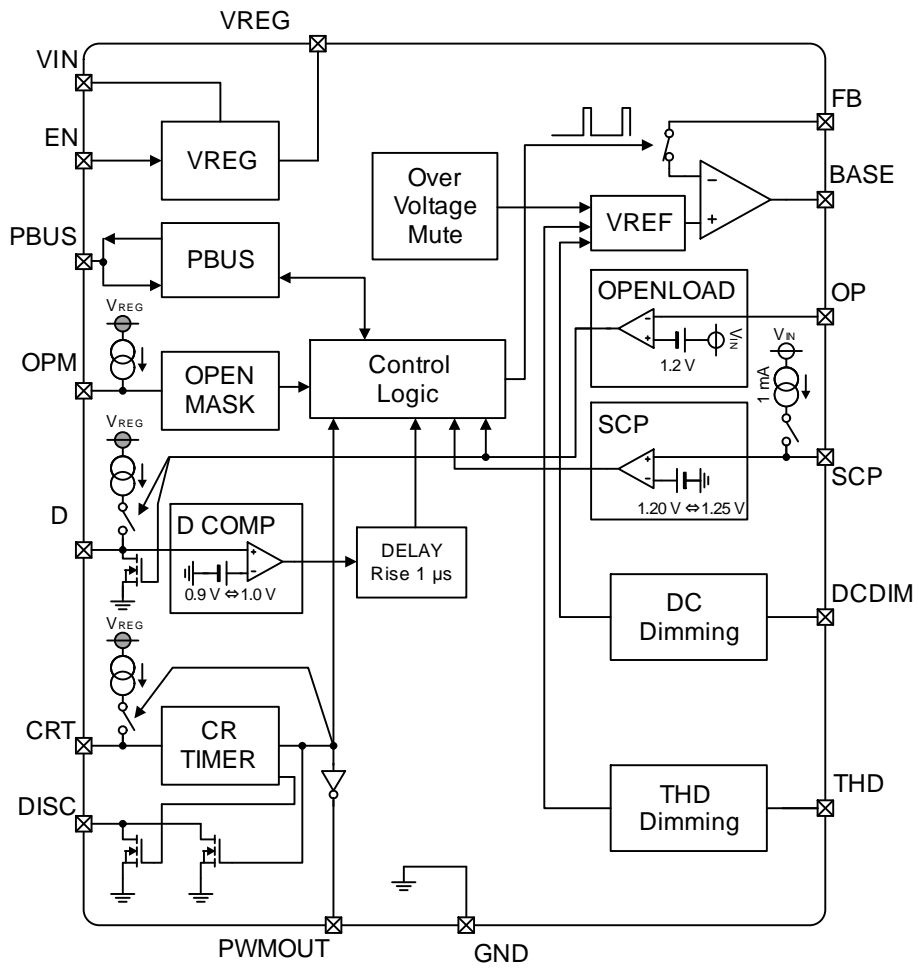

Absolute Maximum Ratings (Ta=25 °C)

Parameter	Symbol	Rating	Unit
Power Supply Voltage(VIN)	V _{IN}	-0.3 to +70.0	V
EN, CRT, DISC Pin Voltage	V _{EN} , V _{CRT} , V _{DISC}	-0.3 to +70.0	V
FB, BASE, OP, SCP Pin Voltage	V _{FB} , V _{BASE} , V _{OP} , V _{SCP}	-0.3 to V _{IN} +0.3	V
VIN-FB, VIN-BASE Inter-Pin Voltage	V _{IN_FB} , V _{IN_BASE}	-0.3 to +5.0	V
PBUS, VREG DCDIM, THD Pin Voltage	V _{PBUS} , V _{REG} , V _{DCDIM} , V _{THD}	-0.3 to +7.0	V
PWMOUT, OPM, D Pin Voltage	V _{PWMOUT} , V _{OPM} , V _D	-0.3 to V _{REG} +0.3	V
Storage Temperature Range	T _{stg}	-55 to +150	°C
Maximum Junction Temperature	T _{jmax}	150	°C

Caution 1: Operating the IC over the absolute maximum ratings may damage the IC. The damage can either be a short circuit between pins or an open circuit between pins and the internal circuitry. Therefore, it is important to consider circuit protection measures, such as adding a fuse, in case the IC is operated over the absolute maximum ratings.

Caution 2: Should by any chance the maximum junction temperature rating be exceeded the rise in temperature of the chip may result in deterioration of the properties of the chip. In case of exceeding this absolute maximum rating, design a PCB with thermal resistance taken into consideration by increasing board size and copper area so as not to exceed the maximum junction temperature rating.

Thermal Resistance^(Note 1)

Parameter	Symbol	Thermal Resistance (Typ)		Unit
		1s ^(Note 3)	2s2p ^(Note 4)	
HTSSOP-B20				
Junction to Ambient	θ _{JA}	143.0	26.8	°C/W
Junction to Top Characterization Parameter ^(Note 2)	Ψ _{JT}	8	4	°C/W

^(Note 1) Based on JE51-2A(Still-Air).

^(Note 2) The thermal characterization parameter to report the difference between junction temperature and the temperature at the top center of the outside surface of the component package.

^(Note 3) Using a PCB board based on JE51-3.

^(Note 4) Using a PCB board based on JE51-5, 7.

Layer Number of Measurement Board	Material	Board Size
Single	FR-4	114.3 mm x 76.2 mm x 1.57 mmt

Top	
Copper Pattern	Thickness
Footprints and Traces	70 μm

Layer Number of Measurement Board	Material	Board Size	Thermal Via ^(Note 5)	
			Pitch	Diameter
4 Layers	FR-4	114.3 mm x 76.2 mm x 1.6 mmt	1.20 mm	Φ0.30 mm

Top		2 Internal Layers		Bottom	
Copper Pattern	Thickness	Copper Pattern	Thickness	Copper Pattern	Thickness
Footprints and Traces	70 μm	74.2 mm x 74.2 mm	35 μm	74.2 mm x 74.2 mm	70 μm

^(Note 5) This thermal via connects with the copper pattern of all layers.

Recommended Operating Conditions

Parameter	Symbol	Min	Typ	Max	Unit
Supply Voltage ^(Note 1) ^(Note 2)	V _{IN}	4.5	13.0	19.0	V
CR TIMER Frequency	f _{PWM}	100	-	5000	Hz
PWM Minimum Pulse Width ^(Note 3)	t _{MIN}	10	-	-	μs
Operating Temperature	Topr	-40	-	+125	°C

(Note 1) ASO should not be exceeded

(Note 2) At start-up time, apply a voltage 5 V or more once. The value is the voltage range after the temporary rise to 5 V or more.

(Note 3) At connecting the external PNP Tr. (2SAR573DFHG (ROHM), 1 pcs). That is the same when the pulse input to the CRT pin.

Operating Conditions

Parameter	Symbol	Min	Max	Unit
Capacitor Connecting VIN Pin 1	C _{VIN1}	1.0	-	μF
Capacitor Connecting VIN Pin 2	C _{VIN2} ^(Note 4)	0.047	-	μF
Capacitor Connecting VREG Pin	C _{VREG} ^(Note 5)	1.0	4.7	μF
Capacitor Connecting LED Anode	C _{LED}	0.10	0.68	μF
Capacitor for Setting CRT Timer	C _{CRT}	0.01	0.22	μF
Resistor for Setting CRT Timer	R _{CRT}	0.1	50.0	kΩ
Resistor for Setting LED Current	R _{FB1} , R _{FB2} ^(Note 6)	0.8	6.5	Ω
Resistor for Disable LED Open Detection Voltage Setting at Reduced Voltage	R _{OPM}	25	55	kΩ
Resistor for DCIN Pull-down	R _{DCIN}	-	10	kΩ
Resistor for Setting DC Dimming	R _{DCCDIM1}	4.7	50.0	kΩ
Resistor for Setting Thermal De-rating	R _{THD}	4.7	50.0	kΩ
Capacitor for Setting Disable LED Open Detection Time	C _D ^(Note 5)	0.001	0.100	μF
Resistor for Limiting Base Current	R _{LIM}	See Features Description 5		Ω
External PNP Transistor	Q ₁	(Note 7)		-

(Note 4) Recommended ceramic capacitor. ROHM Recommended Value (0.1 μF GCM155R71H104KE37 murata)

(Note 5) Recommended ceramic capacitor. Setting the Disable LED Open Detection Time less than PWM minimum pulse width.

(See Features Description, Section 5 –LED Open Detection Function).

(Note 6) At connecting the external PNP Tr. 2SAR573DFHG (ROHM), 1 pcs.

(Note 7) For external PNP transistor, Use the recommended device 2SAR573DFHG for this IC.

While using non-recommended part device, check spec of part(hfe, parasitic capacitance) and validate the design on actual board.

Check hfe of the part to design base current limit resistor. (See Features Description, section 5).

As for parasitic capacitance, Evaluate over shoot of I_{LED} on actual board. (See Features Description, Section 8 -Evaluation example, I_{LED} pulse width at PWM Dimming operation).

Electrical Characteristics(Unless otherwise specified Ta=-40 °C to +125 °C, V_{IN}=13 V, C_{VREG}=1.0 μF, PNP Transistor=2SAR573DFHG)

Parameter	Symbol	Limit			Unit	Conditions
		Min	Typ	Max		
[Circuit Current I_{VIN}]						
Circuit Current at Stand-by Mode	I _{VIN1}	-	0	10	μA	V _{EN} =0 V V _{FB} =V _{IN}
Circuit Current at Normal Mode	I _{VIN2}	-	2.0	5.0	mA	V _{EN} =V _{IN} , V _{FB} =V _{IN} -1.0 V Base Current Subtracted
Circuit Current at LED Open Detection	I _{VIN3}	-	2.0	5.0	mA	V _{EN} =V _{IN} , V _{FB} =V _{IN} -1.0 V
Circuit Current at PBUS=Low	I _{VIN4}	-	2.0	5.0	mA	V _{EN} =V _{IN} , V _{FB} =V _{IN} -1.0 V V _{PBUS} =0 V
[VREG Voltage]						
VREG Pin Voltage	V _{REG}	4.85	5.00	5.15	V	I _{VREG} =-100 μA Ta=25 °C to 125 °C
		4.75	5.00	5.25	V	I _{VREG} =-100 μA Ta=-40 °C to +125 °C
VREG Pin Current Capability	I _{VREG}	-1.0	-	-	mA	
[DRV]						
FB Pin Voltage	V _{FBREG}	630	650	670	mV	V _{FBREG} =V _{IN} -V _{FB} R _{FB1} =R _{FB2} =1.8 Ω, Ta=25 °C to 125 °C
		617	650	683	mV	V _{FBREG} =V _{IN} -V _{FB} R _{FB1} =R _{FB2} =1.8 Ω, Ta=-40 °C to +125 °C
FB Pin Input Current	I _{FB}	7.5	15	30	μA	V _{FB} =V _{IN}
BASE Pin Sink Current Capability	I _{BASE}	10	-	-	mA	V _{FB} =V _{IN} , V _{BASE} =V _{IN} -1.5 V Ta=25 °C
BASE Pin Pull-up Resistor	R _{BASE}	0.5	1.0	1.5	kΩ	V _{CRT} =0 V V _{FB} =V _{IN} , V _{BASE} =V _{IN} -1.0 V
[LED Current De-rating function (DC Dimming function)]						
DC Dimming Enable Voltage	V _{DDON}	V _{REG} x0.42	-	V _{REG} x0.8	V	Enable at V _{DCCDIM} < V _{DDON}
DC Dimming Gain	D _{DG}	710	730	750	mV/V	$\frac{\Delta V_{FBREG}}{V_{THD}}$: 0.75 V → 0.35 V
[DCCDIM]						
FB Pin Voltage V _{DCCDIM} =2.0 V(V _{REG} x0.4)	V _{FB_DC1}	1.336	1.378	1.420	V	V _{THD} > V _{DCCDIM} +0.25 V
FB Pin Voltage V _{DCCDIM} =0.75 V(V _{REG} x0.15)	V _{FB_DC2}	452	466	480	mV	V _{THD} > V _{DCCDIM} +0.25 V
FB Pin Voltage V _{DCCDIM} =0.50 V(V _{REG} x0.1)	V _{FB_DC3}	272	284	296	mV	V _{THD} > V _{DCCDIM} +0.25 V
FB Pin Voltage V _{DCCDIM} =0.35 V(V _{REG} x0.07)	V _{FB_DC4}	163	174	185	mV	V _{THD} > V _{DCCDIM} +0.25 V
DCCDIM Pin Input Voltage range	V _{DCCDIM_R}	V _{REG} x0.07	-	V _{REG} x0.4	V	
[THD]						
FB Pin Voltage V _{THD} =0.75 V	V _{FB_THD1}	438	466	494	mV	V _{DCCDIM} > V _{THD} +0.25 V
FB Pin Voltage V _{THD} =0.50 V	V _{FB_THD2}	266	284	301	mV	V _{DCCDIM} > V _{THD} +0.25 V
FB Pin Voltage V _{THD} =0.35 V	V _{FB_THD3}	160	174	188	mV	V _{DCCDIM} > V _{THD} +0.25 V

Electrical Characteristics – continued(Unless otherwise specified Ta=-40 °C to +125 °C, V_{IN}=13 V, C_{VREG}=1.0 μF, PNP Transistor=2SAR573DFHG)

Parameter	Symbol	Limit			Unit	Conditions
		Min	Typ	Max		
[Over Voltage Mute Function (OVM)]						
Over Voltage Mute Start Voltage	V _{OVMS}	20.0	22.0	24.0	V	$\Delta V_{FB}=10.0\text{ mV}$ $\Delta V_{FB}=V_{FB}(@V_{IN}=13\text{ V})-V_{FB}(@V_{IN}=V_{OVMS})$
Over Voltage Mute Gain	V _{OVMG}	-	-25	-	mV/V	$\Delta V_{FB}/\Delta V_{IN}$
[CR TIMER]						
CRT Pin Charge Current	I _{CRT}	36	40	44	μA	
CRT Pin Charge Voltage	V _{CRT_CHA}	0.72	0.80	0.88	V	
CRT Pin Discharge Voltage 1	V _{CRT_DIS1}	1.80	2.00	2.20	V	
CRT Pin Discharge Voltage 2	V _{CRT_DIS2}	2.10	2.40	3.00	V	When V _{CRT} > V _{CRT_DIS2} , R _{D1} → R _{D2}
CRT Pin Charge Resistor	R _{CHA}	28.5	30.0	31.5	kΩ	$R_{CHA}=(V_{CRT_DIS1}-V_{CRT_CHA})/I_{CRT}$
CRT Discharge Constant	V_{CRT_CHA}/V_{CRT_DIS1}	0.38	0.40	0.42	V/V	
DISC Pin ON Resistor 1	R _{DISC1}	20	50	100	Ω	I _{DISC} =10 mA
DISC Pin ON Resistor 2	R _{DISC2}	2.5	5.0	10	kΩ	I _{DISC} =100 μA
PWMOUT Pin Output High Voltage	V _{PWMOUTH}	4.0	-	5.5	V	I _{PWMOUT} = -100μA
PWMOUT Pin Output Low Voltage	V _{PWMOUTL}	-	-	0.5	V	I _{PWMOUT} = 100μA
PWMOUT Pin Sink Current Capability	I _{PWMOUT_SINK}	-	-	0.5	mA	
PWMOUT Pin Source Current Capability	I _{PWMOUT_SOURCE}	-0.5	-	-	mA	
CRT Pin Leakage Current	I _{CRT_LEAK}	-	-	10	μA	V _{CRT} =V _{IN}
[LED Open Detection]						
LED Open Detection Voltage	V _{OPD}	1.1	1.2	1.3	V	V _{OPD} =V _{IN} -V _{OP}
OP Pin Input Current	I _{OP}	19	21	23	μA	V _{OP} =V _{IN} -0.5 V
[Disable LED Open Detection Function at Reduced-Voltage]						
OPM Pin Source Current	I _{OPM}	38	40	42	μA	
VIN Pin Disable LED Open Detection Voltage at Reduced-Voltage	V _{IN_OPM}	V _{OPM} x 5.9	V _{OPM} x 6.0	V _{OPM} x 6.1	V	
OPM Pin Input Voltage Range	V _{OPM_R}	1.0	-	2.2	V	
[Disable LED Open Detection Time Setting D Function]						
Input Threshold Voltage	V _{DH}	0.9	1.0	1.1	V	
D Pin Source Current	I _{DSOURCE}	100	230	400	μA	
D Pin ON Resistor	R _D	-	-	950	Ω	I _{D_EXT} =100 μA

Electrical Characteristics – continued(Unless otherwise specified Ta=-40 °C to +125 °C, V_{IN}=13 V, C_{VREG}=1.0 μF, PNP Transistor=2SAR573DFHG)

Parameter	Symbol	Limit			Unit	Conditions
		Min	Typ	Max		
[Short Circuit Protection (SCP)]						
Short Circuit Protection Voltage	V _{SCPD}	1.10	1.20	1.30	V	
Short Circuit Protection Release Voltage	V _{SCPR}	1.15	1.25	1.35	V	
Short Circuit Protection Hysteresis Voltage	V _{SCPHYS}	-	50	-	mV	
SCP Pin Source Current	I _{SCP}	0.2	1.0	2.0	mA	
SCP Pin Source Current ON Voltage	V _{SCP2}	1.15	1.30	1.45	V	
SCP Delay Time	t _{SCP}	10	20	45	μs	
[PBUS]						
Input High Voltage	V _{PBUSH}	2.4	-	-	V	
Input Low Voltage	V _{PBUSL}	-	-	0.6	V	
Hysteresis Voltage	V _{PBUSHYS}	-	200	-	mV	
PBUS Pin Source Current	I _{PBUS}	75	150	300	μA	V _{EN} =5 V
PBUS Pin Output Low Voltage	V _{PBUS_OL}	-	-	0.6	V	I _{PBUS_EXT} =3 mA
PBUS Pin Output High Voltage	V _{PBUS_OH}	3.5	4.5	5.5	V	I _{PBUS_EXT} =-10 μA
PBUS Pin Leakage Current	I _{PBUS_LEAK}	-	-	10	μA	V _{PBUS} =7 V
[EN]						
Input High Voltage	V _{ENH}	2.4	-	-	V	
Input Low Voltage	V _{ENL}	-	-	0.6	V	
Hysteresis Voltage	V _{ENHYS}	-	60	-	mV	
Pin Input Current	I _{EN}	-	7	15	μA	V _{EN} =5 V
[UVLO VIN]						
UVLO Detection Voltage	V _{UVLOD}	3.88	4.10	4.32	V	V _{IN} : Sweep down
UVLO Release Voltage	V _{UVLOR}	4.25	4.50	4.75	V	V _{IN} : Sweep up, V _{REG} > 3.75 V
UVLO Hysteresis Voltage	V _{HYS}	-	0.4	-	V	

Typical Performance Curves (Reference Data)

(Unless otherwise specified $T_a=25\text{ }^\circ\text{C}$, $V_{IN}=13\text{ V}$, $C_{VREG}=1.0\text{ }\mu\text{F}$, PNP Transistor=2SAR573DFHG)

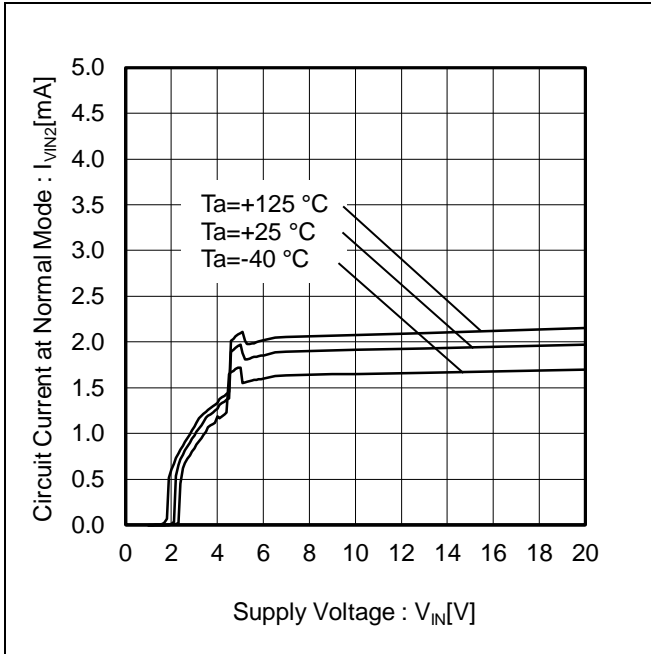

Figure 1. Circuit Current at Normal Mode vs Supply Voltage

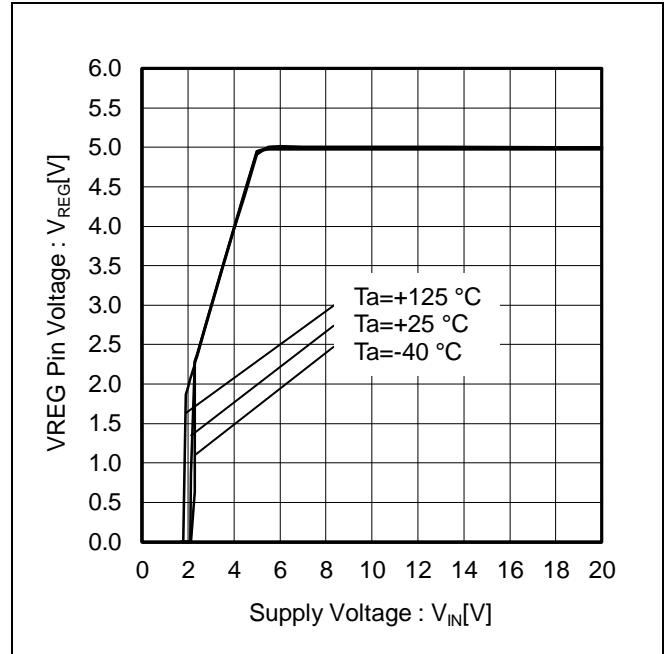

Figure 2. VREG Pin Voltage vs Supply Voltage

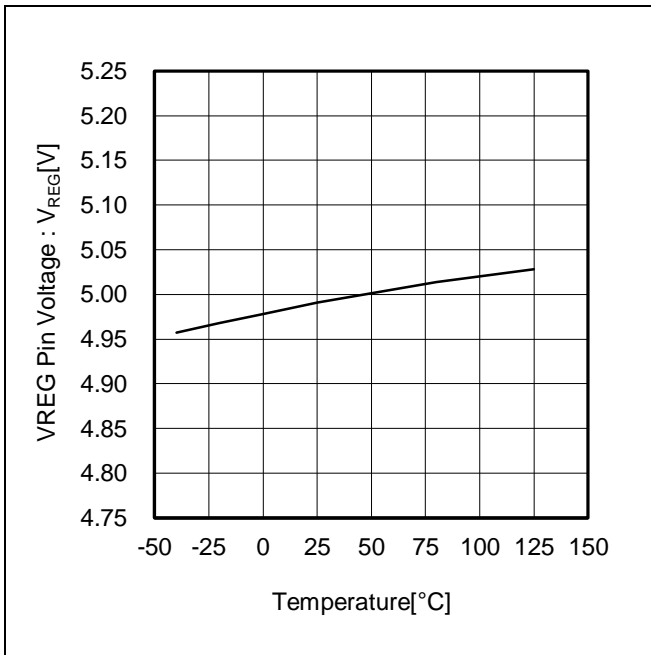

Figure 3. VREG Pin Voltage vs Temperature

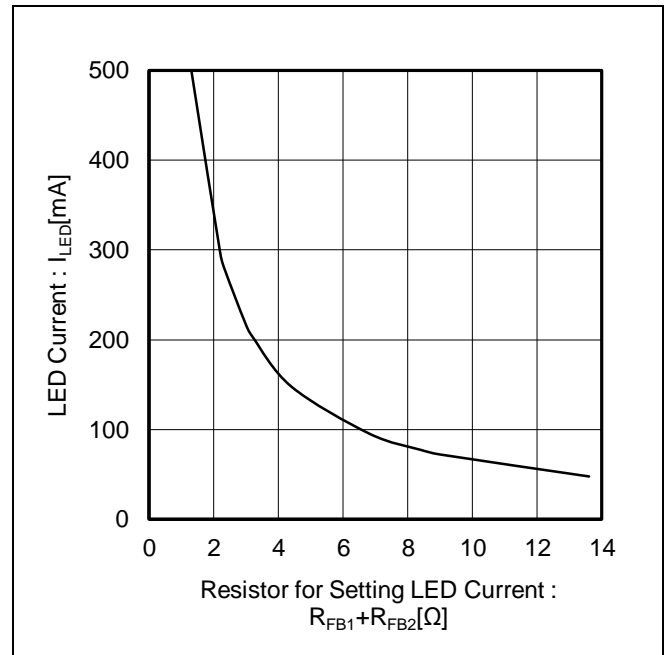

Figure 4. LED Current vs Resistor for Setting LED Current

Typical Performance Curves (Reference Data) – continued

(Unless otherwise specified Ta=25 °C, VIN=13 V, C_{VREG}=1.0 μF, PNP Transistor=2SAR573DFHG)

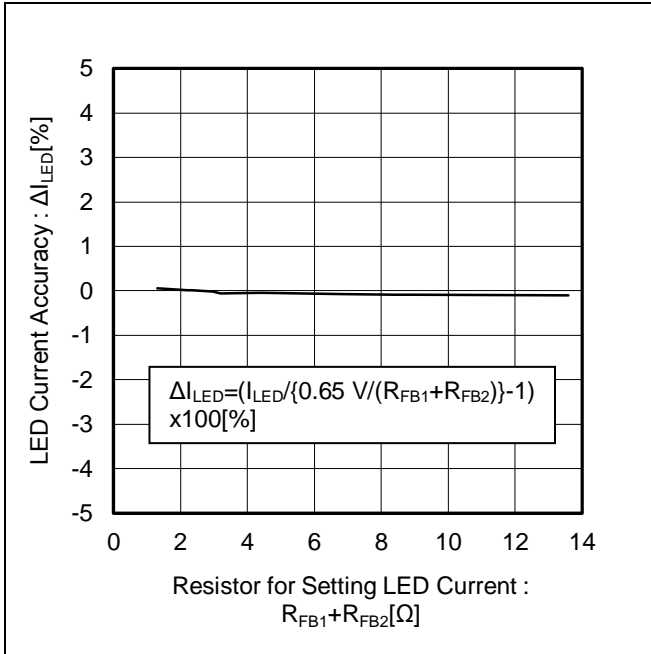

Figure 5. LED Current Accuracy vs Resistor for Setting LED Current

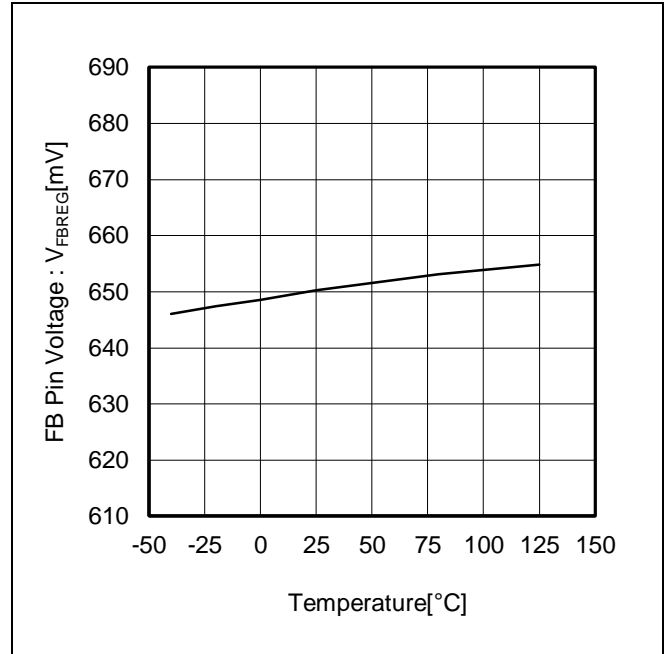

Figure 6. FB Pin Voltage vs Temperature

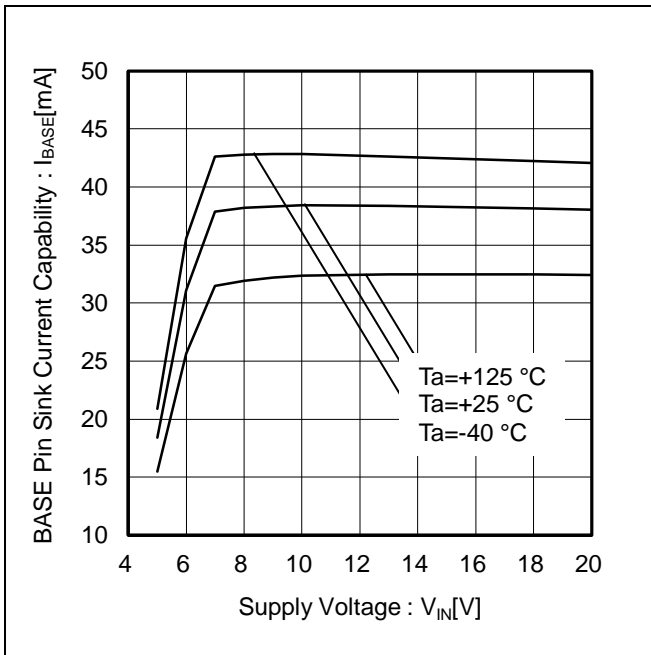

Figure 7. BASE Pin Sink Current Capability vs Supply Voltage

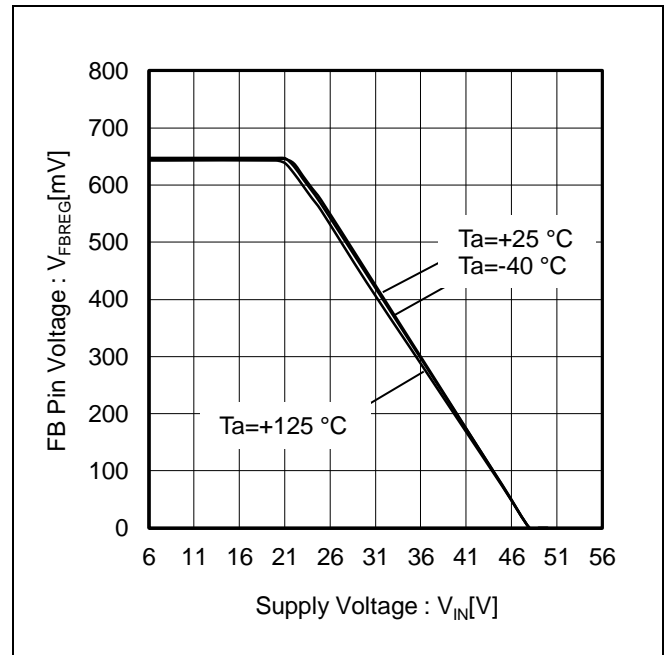

Figure 8. FB Pin Voltage vs Supply Voltage

Typical Performance Curves (Reference Data) – continued

(Unless otherwise specified $T_a=25\text{ }^\circ\text{C}$, $V_{IN}=13\text{ V}$, $C_{VREG}=1.0\text{ }\mu\text{F}$, PNP Transistor=2SAR573DFHG)

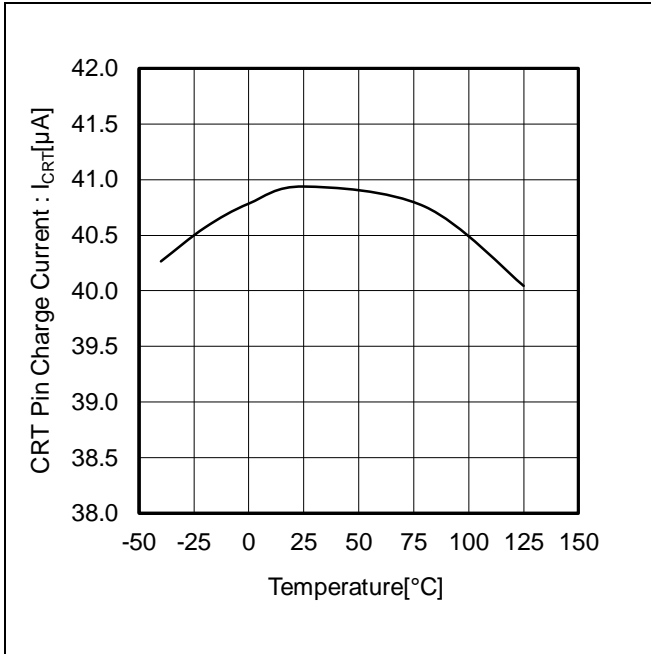

Figure 9. CRT Pin Charge Current vs Temperature

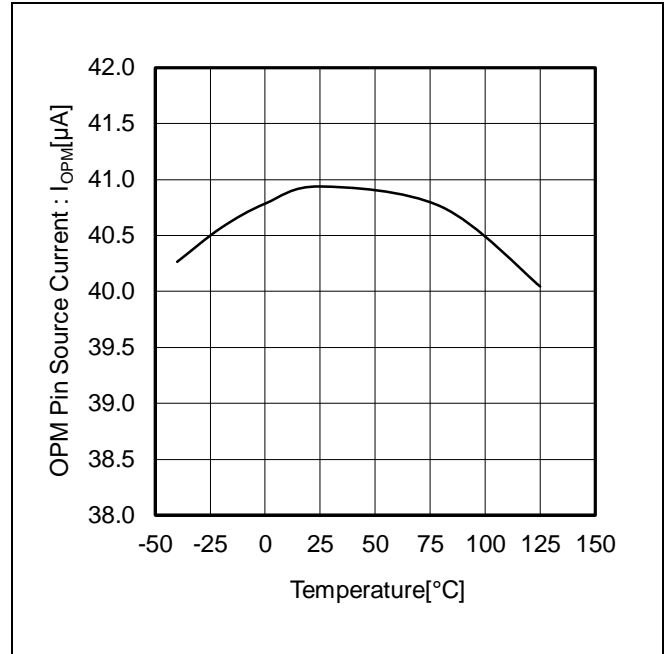

Figure 10. OPM Pin Source Current vs Temperature

Typical Performance Curves (Reference Data) – continued

(Unless otherwise specified $T_a=25\text{ }^\circ\text{C}$, $V_{IN}=13\text{ V}$, $C_{VREG}=1.0\text{ }\mu\text{F}$, PNP Transistor=2SAR573DFHG)

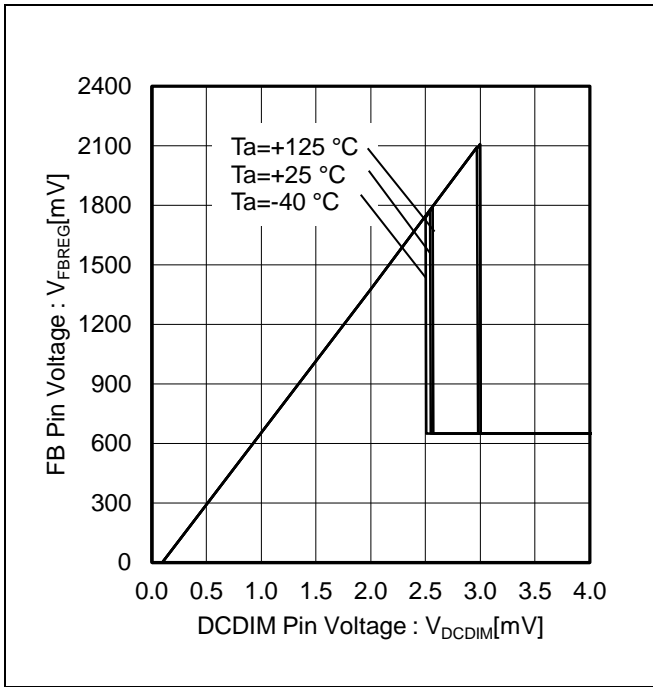

Figure 11. FB Pin Voltage vs DCDIM Pin Voltage

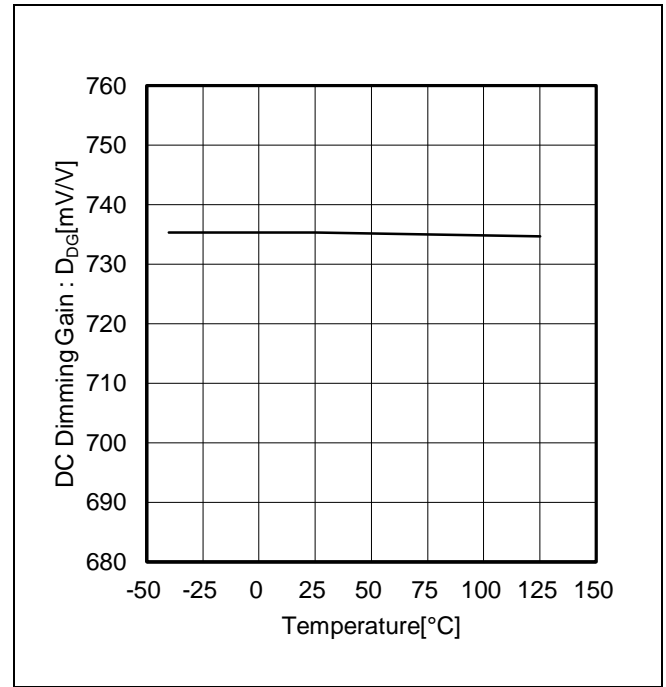

Figure 12. DC Dimming Gain vs Temperature

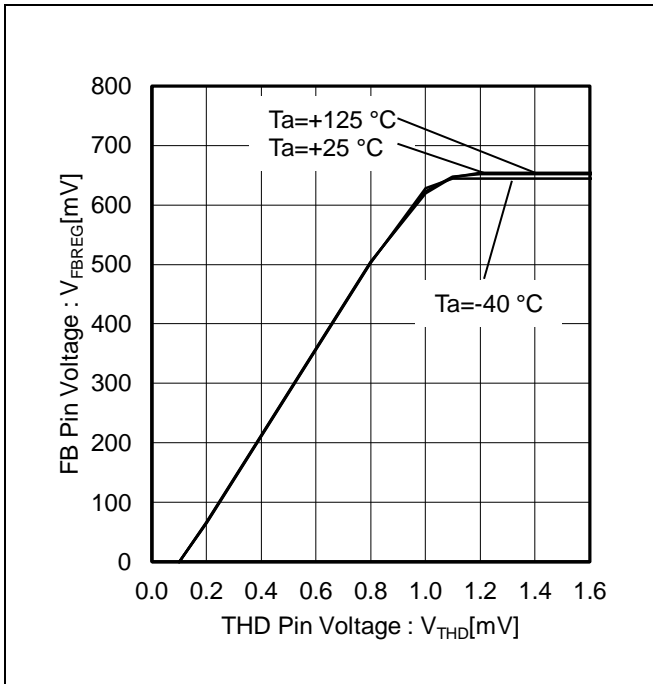

Figure 13. FB Pin Voltage vs THD Pin Voltage

Description of Function – continued

3. Table of Operations

The PWM dimming mode switches to DC control depending on the CRT pin voltage.

The switching conditions are as shown in the table below. When $V_{IN} > 22.0$ V (Typ), LED current is limited to reduce the heat dissipation of external PNP transistor.

Depending on the OP pin and the SCP pin voltage status, detect LED open or short circuit then LED current is turned OFF. LED current is also turned OFF when Low signal is input to the PBUS pin.

In addition, UVLO and TSD further increases system reliability.

For each functions, refer to Description of Function.

Operation Mode	CRT Pin	Detecting Condition		LED Current (I_{LED})	PBUS Pin
		[Detect]	[Release]		
Stand-by Mode ^(Note 1)	-	$V_{EN} \leq 0.6$ V	$V_{EN} \geq 2.4$ V	OFF ^(Note 3)	Hi-Z
DC	$V_{CRT} \geq 2.0$ V (Typ)	-	-	50 mA to 400 mA	High 4.5 V (Typ)
PWM Dimming	See Features Description 4	-	-	See Features Description 4	High 4.5 V (Typ)
DC Dimming	-	$V_{DCDIM} \leq V_{REG} \times 0.42$	$V_{DCDIM} > V_{REG} \times 0.8$	See Features Description 9	High 4.5 V(Typ)
Thermal De-rating	-	$V_{THD} \leq 1.0$ V(Typ)	$V_{THD} > 1.25$ V	See Features Description 10	High 4.5 V(Typ)
Over Voltage Mute	-	$V_{IN} > 22.0$ V (Typ)	$V_{IN} \leq 22.0$ V (Typ)	See Features Description 12	High 4.5 V (Typ)
LED Open Detection ^(Note 2)	-	$V_{OP} \geq V_{IN} - 1.2$ V (Typ)	$V_{OP} < V_{IN} - 1.2$ V (Typ)	OFF ^(Note 3)	Low
Short Circuit Protection (SCP)	-	$V_{SCP} \leq 1.20$ V (Typ)	$V_{SCP} \geq 1.25$ V (Typ)	OFF ^(Note 3)	Low
PBUS Control OFF	-	$V_{PBUS} \leq 0.6$ V	$V_{PBUS} \geq 2.4$ V	OFF ^(Note 3)	Input $V_{PBUS} \leq 0.6$ V
UVLO	-	$V_{IN} \leq 4.10$ V (Typ) or $V_{REG} \leq 3.75$ V (Typ)	$V_{IN} \geq 4.50$ V (Typ) or $V_{REG} \geq 4.00$ V (Typ)	OFF ^(Note 3)	High
TSD	-	$T_j \geq 175$ °C (Typ)	$T_j \leq 150$ °C(Typ)	OFF ^(Note 3)	Hi-Z

(Note 1) Circuit current 0 μ A (Typ)

(Note 2) In regard to the sequence of LED current OFF, see Features Description 5.

(Note 3) The BASE pin sink current: OFF, and LED current(I_{LED}): OFF.

Description of Function – continued

4. PWM Dimming Operation

PWM Dimming is performed with the following circuit. The dimming cycle and ON Duty Width, can be set by values of the external components (C_{CRT}, R_{CRT}). Connect the CRT pin to the VIN pin and the DISC pin to GND or open if it is not used.

The CR timer function is activated if DC SW is OPEN. To perform PWM dimming of LED current, a triangular waveform is generated at the CRT pin. The **LED current (I_{LED}) is turned OFF** while CRT voltage is ramp up, and **LED current(I_{LED}) is turned ON** while CRT voltage is ramp down.

When V_{CRT} ≥ V_{CRT_DIS1}(2.0 V(Typ)), dimming mode turns to DC Control. When V_{CRT} > V_{CRT_DIS2}(2.4 V(Typ)), the DISC pin ON resistor changes from R_{DISC1}(50 Ω(Typ)) to R_{DISC2}(5 kΩ(Typ)), and the power consumption of the IC is reduced by reducing the inflow current of the DISC pin.

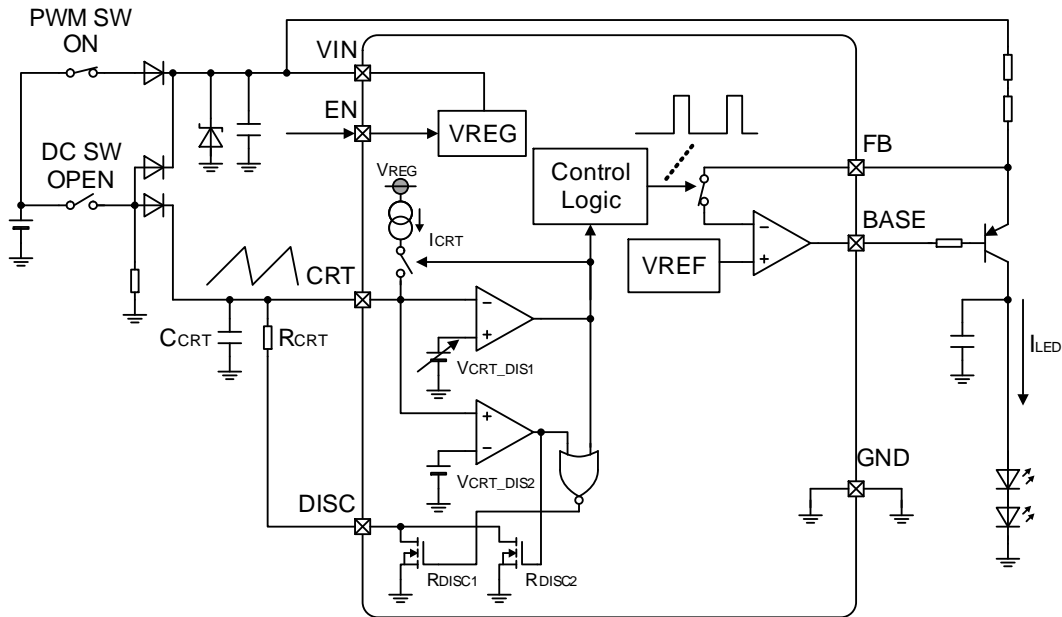

Figure 15. PWM Dimming Operation

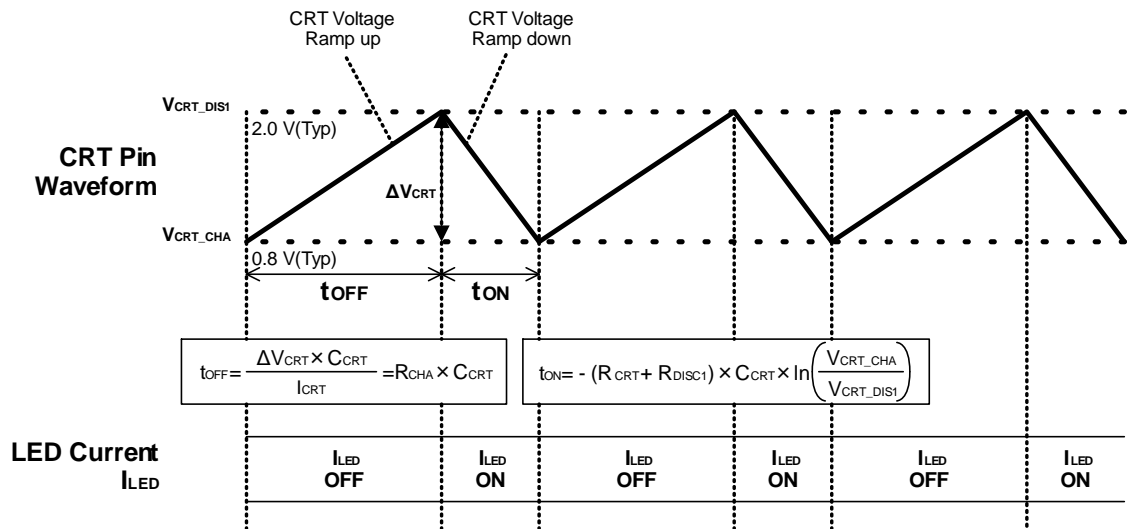

Figure 16. PWM Dimming Operation

4. PWM Dimming Operation – continued

- (1) CRT ramp up Time t_{OFF} and CRT ramp down Time t_{ON}
 CRT ramp up Time t_{OFF} and CRT ramp down Time t_{ON} can be defined from the following equations.
 Make sure that t_{ON} is set PWM Minimum Pulse Width t_{MIN} 10 μ s or more.

$$t_{OFF} = \frac{\Delta V_{CRT} \times C_{CRT}}{I_{CRT}} = R_{CHA} \times C_{CRT} \quad [\text{s}]$$

$$t_{ON} = -(R_{CRT} + R_{DISC1}) \times C_{CRT} \times \ln\left(\frac{V_{CRT_CHA}}{V_{CRT_DIS1}}\right) \quad [\text{s}]$$

where:

I_{CRT} is the CRT pin charge current, 40 μ A (Typ).

R_{CHA} is the CRT pin charge resistor, 30 k Ω (Typ).

R_{DISC1} is the DISC pin ON resistor1, 50 Ω (Typ).

V_{CRT_CHA} is the CRT pin charge voltage, 0.8 V (Typ).

V_{CRT_DIS1} is the CRT pin discharge voltage1, 2.0 V (Typ).

- (2) PWM Dimming Frequency f_{PWM}
 PWM Dimming Frequency is defined by t_{ON} and t_{OFF} .

$$f_{PWM} = \frac{1}{t_{ON} + t_{OFF}} \quad [\text{Hz}]$$

- (3) ON Duty(D_{ON})
 PWM ON duty is defined by t_{ON} and t_{OFF} .

$$D_{ON} = \frac{t_{ON}}{t_{ON} + t_{OFF}} \quad [\%]$$

(Example) In case of $R_{CRT}=3.6$ k Ω , $C_{CRT}=0.1$ μ F (Typ)

$$t_{OFF} = R_{CHA} \times C_{CRT} = 30 \times 0.1 = 3.0 \quad [\text{ms}]$$

$$t_{ON} = -(R_{CRT} + R_{DISC1}) \times C_{CRT} \times \ln(V_{CRT_CHA}/V_{CRT_DIS1}) \\ = -(3.6 + 50) \times 0.1 \times \ln(0.8/2.0) = 0.334 \quad [\text{ms}]$$

$$f_{PWM} = 1/(t_{ON} + t_{OFF}) = 1/(3.0 + 0.334) = 300 \quad [\text{Hz}]$$

$$D_{ON} = t_{ON}/(t_{ON} + t_{OFF}) = 0.334/(3.0 + 0.334) = 10.0 \quad [\%]$$

[PWM Dimming Operation Using External Signal]

In case external PWM input to the CRT pin, make sure that input pulse high voltage ≥ 2.2 V and pulse low voltage ≤ 0.6 V. Also open the DISC pin or connect to GND.

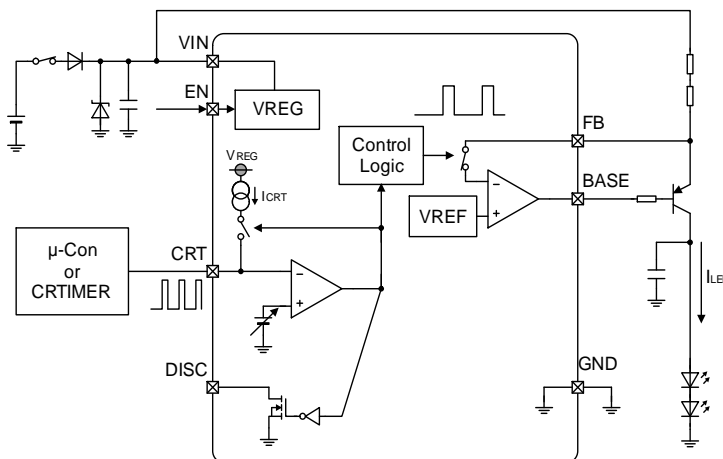

Figure 17. PWM Dimming Operation Using External Signal

4. PWM Dimming Operation – continued

●About deviation of CRT ramp up/down time with a reverse connection protection diode

If this LSI is used to drive LED like below schematic, there is a possibility of occur CRT ramp up/down time deviation due to characteristics of reverse current I_r diode (D2, D3).

Consider to choose a diode (D2, D3) which is recommended by Rohm or I_r value $1\ \mu\text{A}$ (Max) or less.

Since reverse current flows even with the recommended diodes, connect a resistor of R_{DCN} of $10\ \text{k}\Omega$ or less between Point A and GND so that the voltage at point A does not rise.

Mechanism of deviation of CRT ramp up/down time from set values.

① During the PWM dimming operation mode, Point A on Figure 18 is Hi-Z.

↓

② Reverse current I_r of D2 and D3 goes to Point A.

(Power supply voltage is being input into the cathode of D2, so mainly reverse current of D2 goes into C1.)

→Reverse current I_r of D3 is added to the CRT pin charge current and discharge current, so CRT ramp up/down time deviates from the settings.

↓

③ C1 gets charged, voltage at Point A rises.

↓

④ Point A voltage \geq the CRT pin voltage of each IC.

↓

⑤ V_f occurs in the diodes D3.

↓

⑥ D3 circulate forward current I_f

→Forward current I_f of D3 is added to the CRT pin charge current and discharge current, so CRT ramp up/down time deviates from the settings.

↓

⑦ Repetition of ② to ⑥.

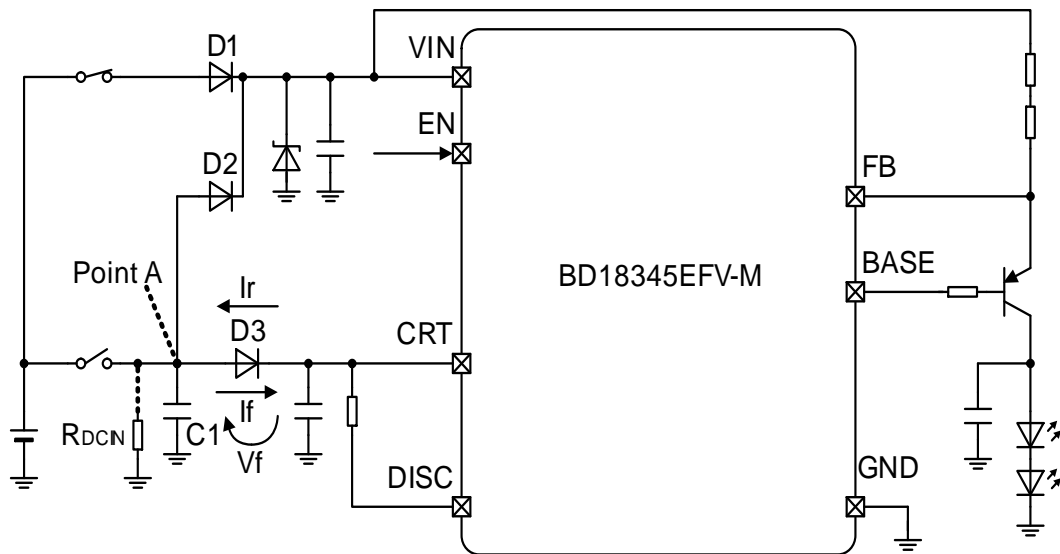

Figure 18. How Reverse Protection Diode Affects the CRT Pin Ramp Up/Down Time

Description of Function – continued

5. LED Open Detection Function

In case any one of the LEDs is in the open state, the IC can detect LED open condition when the OP pin voltage (V_{OP}) meets the following condition: $V_{OP} \geq V_{IN} - 1.2 \text{ V}$ (Typ). As soon as $V_{OP} \geq V_{IN} - 1.2 \text{ V}$ (Typ) condition is achieved, the D pin source current ($230 \mu\text{A}$ (Typ)) turns on and starts charging the disable LED open detection time setting capacitor (C_D). Once the D pin voltage (V_{DH}) becomes 1.0 V (Typ) or more and $1 \mu\text{s}$ (Typ) elapses, the BASE pin sink current (I_{BASE}) is latched OFF and the PBUS pin voltage (V_{PBUS}) is switched to Low.

[Base Current Limit Resistance (R_{LIM})]

The OP pin voltage V_{OP} at LED open is defined by the following formula:
(Note that the external PNP Tr. goes into the saturation mode when the collector is open, it becomes the following formula.)

$$V_{OP} = V_{IN} - \{(R_{FB1} + R_{FB2}) \times I_{BASE_MAX} + V_{CE_PNP}\} \quad [V]$$

$$I_{BASE_MAX} = 6.0V / R_{LIM} \quad [A]$$

$$(I_{BASE_MAX} < 80 \text{ mA})$$

where:

R_{FB1}, R_{FB2} is the LED current setting resistance.

I_{BASE_MAX} is a maximum sink current of the BASE pin.

R_{LIM} is the resistor for limiting a sink current of the BASE pin.

V_{CE_PNP} is the external PNP Tr. Collector-emitter voltage (Note: $I_{CE} = I_{OP}$ ($23 \mu\text{A}$ (Max)))).

Determine the BASE current limit resistance R_{LIM} to ensure that the OP pin voltage when the LED is open should meet the following condition: $V_{OP} > V_{IN} - 1.2 \text{ V}$ (Typ).

Also note that the BASE current limit resistance must meet the following condition in order to obtain the BASE current to be needed during normal LED operation.

$$4.0 / R_{LIM} > I_{LED} / hfe_{MIN} \quad [A]$$

where:

hfe_{MIN} is the minimum external PNP Tr. hfe.

For the D pin, it is possible to set the disable time t_D from when the OP pin voltage meets the condition " $V_{OP} > V_{IN} - 1.2 \text{ V}$ (Typ)" until the BASE pin sink current (I_{BASE}) is latched off, according to the following formula. **Note that the disable time must be shorter than or equal to the ON pulse width of the PWM dimming t_{ON} .**

$$t_{ON} > t_D = \frac{C_D \times V_{DH}}{I_{DSOURCE}} \quad [s]$$

where:

t_{ON} is the ON pulse width of the PWM dimming (CRT ramp down time).

C_D is the disable LED open detection time setting capacitor.

V_{DH} is the D pin input threshold voltage, 1.0 V (Typ).

$I_{DSOURCE}$ is the D pin source current, $230 \mu\text{A}$ (Typ).

To reset the latched off LED current, EN must be turned-on again (The time when the EN Pin is "L" since the power is turned on again: $50 \mu\text{s}$ or more) or the condition " $UVLO (V_{IN} \leq 4.10 \text{ V}$ or $V_{REG} \leq 3.75 \text{ V})$ " must be fulfilled.

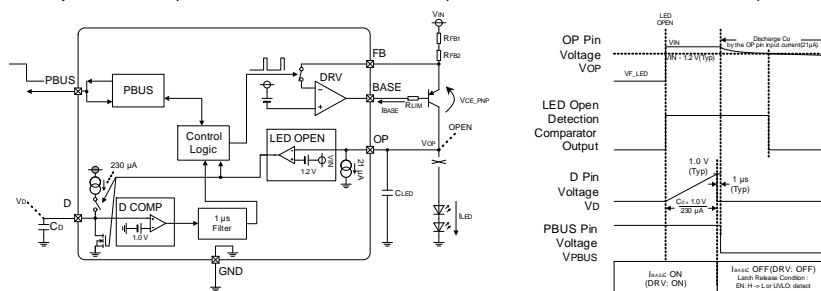

Figure 19. LED Open Detection Timing Chart

Description of Function – continued

6. Disable LED Open Detection Function at Reduced-Voltage

The disable LED open detection function serves to prevent false detection of LED open at the reduced-voltage during the ramp-up/ramp-down of the VIN pin voltage. Even though LED is in the open state, LED open will not be detected until the VIN pin voltage becomes more than Disable Open Detection Voltage at Reduced-Voltage (VIN_OPM). Once VIN_OPM is surpassed, the LED current will be latched OFF (The BASE pin sink current (IBASE) is latched OFF) and the PBUS voltage will be switched to Low following the sequence explained in Description of Function 5. VIN_OPM must be defined by the following formula. (The OPM pin voltage must be set between 1.0 V and 2.2 V.)

$$V_{IN_OPM} \geq V_{IN_OPERR} \quad [V]$$

where:

VIN_OPM is the VIN pin disable open detection voltage at reduced-voltage.

VIN_OPERR is the VIN pin open erroneous detection voltage at reduced-voltage.

$$V_{IN_OPM} = V_{OPM} \times 6.0 \text{ (Typ)} \quad [V]$$

$$V_{OPM} = I_{OPM} \times R_{OPM} \quad [V]$$

$$V_{IN_OPERR} = V_{f_LED} \times N + V_{OPD} \quad [V]$$

where:

VOPM is the OPM pin voltage.

IOPM is the OPM pin source current, 40 μA (Typ)

ROPM is the OPM pin connection resistance.

Vf_LED is the LED Vf.

N is the number of rows of LED.

VOPD is the LED open-circuit detection voltage, 1.2 V (Typ)

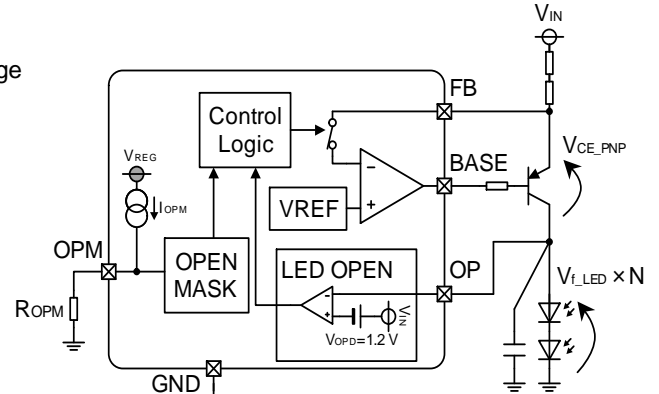

Figure 20. Disable LED Open Detection Function at Reduced-Voltage

•When connecting resistor for heat dispersion, or connecting resistor or diodes between the OP pin and LED anode

The formula to calculate VIN_OPERR will be different from the one above when the current flowing the LED is large and it is necessary to connect a resistor for heat dispersion in series with the LED to reduce the heat generation from the external PNP Tr., when multiple rows of the LEDs are driven, or when connecting a resistor to adjust the threshold voltage for detecting the LED open-circuit. Read the Application Note of BD1834xFV-M series for details.

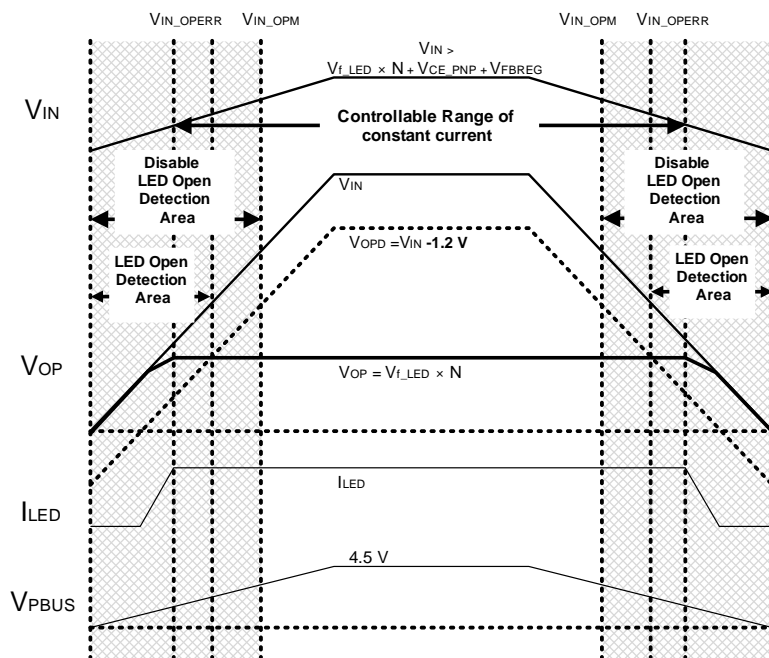

Figure 21. VIN Pin Disable LED Open Detection Voltage at Reduced-Voltage and LED Open Erroneous Detection Voltage at Reduced-Voltage

Description of Function – continued

7. Short Circuit Protection (SCP)

Short Circuit Protection function will be activated by decreasing the SCP pin voltage when the collector of the external PNP Tr. is short to GND. After a lapse of the short circuit protection delay time (t_{SCP}) (20 μ s(Typ)) following the drop of the SCP pin voltage (V_{SCP}) is 1.2 V(Typ) or less, the external PNP Tr. is turned OFF to prevent its thermal destruction, and it can be notify the abnormally to the outside by changing the PBUS pin output to low.

In order to avoid malfunction since the power is turned on, the Short Circuit Protection function will not be activated until $V_{CRT} > 2.0$ V(Typ) after UVLO is reset.

If it is in the short circuit state ($V_{SCP} < 1.2$ V(Typ)) since the power is turned on, the Short Circuit Protection function will be activated when $V_{CRT} > 2.0$ V(Typ) condition is reached and 60 μ s(Typ) passes, after UVLO is reset.

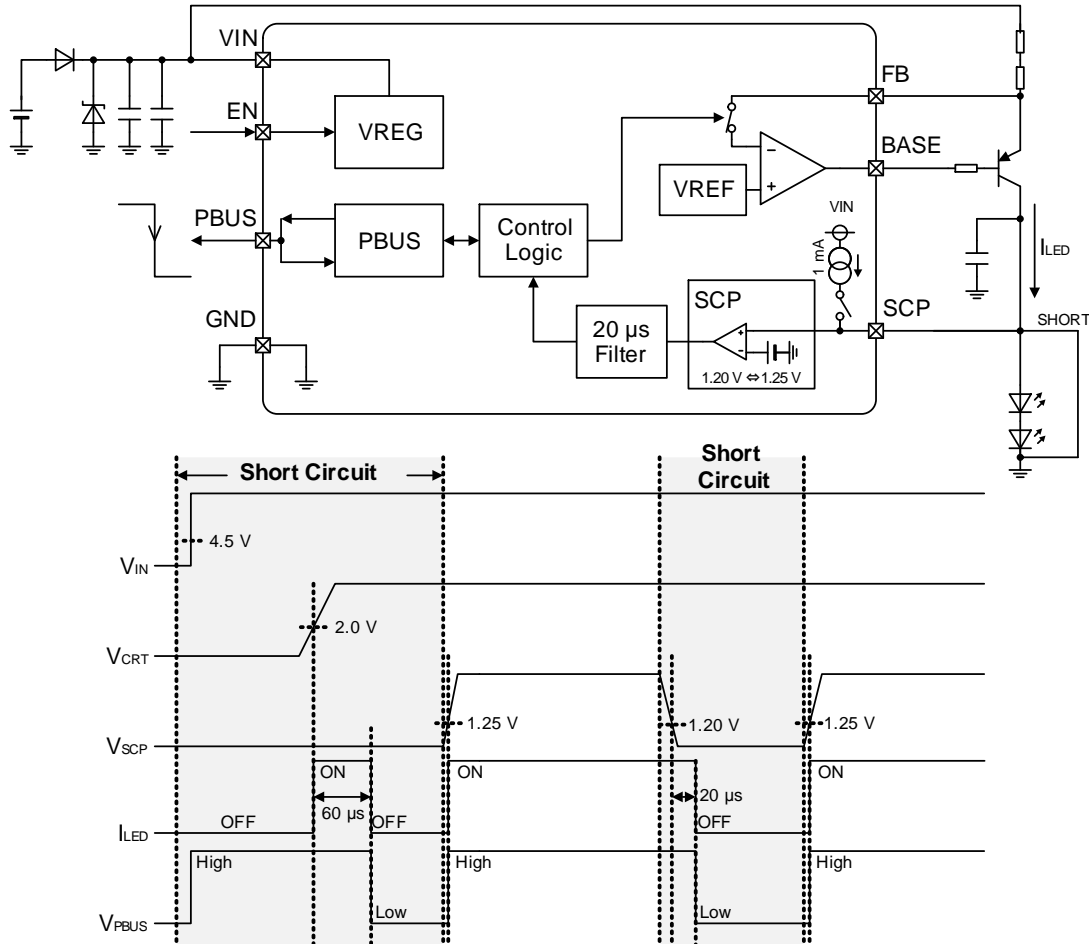

Figure 22. Short Circuit Protection (SCP)

•SCP Pin Source Current

The SCP pin sources the current (1 mA(Typ)) once its voltage (V_{SCP}) drops under 1.3 V in order to prevent the malfunction of the short circuit protection.

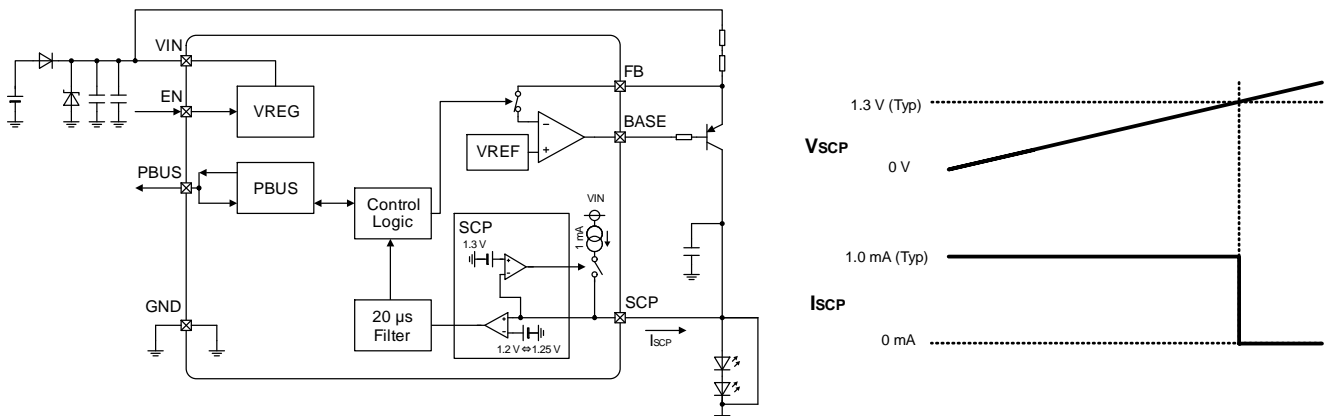

Figure 23. SCP Pin Source Current

Description of Function – continued

8. About the Capacitor of Connecting LED Anode

There is a zone which the output (LED anode) will become high impedance (Hi-Z) at PWM dimming Mode. During this time noise^(Note 1) can decrease LED anode voltage and cause false detection of SHORT condition.

To prevent this, **it is necessary to connect a Capacitor C_{LED} between LED anode and the GND pin nearby pin.**

Make sure that the capacitor of connecting LED anode is the following equation:

$$0.1 \leq C_{LED} \leq 0.68 \quad [\mu\text{F}]$$

In case C_{LED} is set the range from 0.1 μF to 0.68 μF , the I_{LED} current becomes dull, so evaluate I_{LED} waveform in PWM mode operation.

About the example of evaluation, See evaluation example on page 22.

In case a capacitor exceeding the recommended range is connected to LED anode, there is a possibility that delay time of start-up will reach about several ten ms, so special attention is needed.

(Note 1) Conducted noise, Radiated noise, Crosstalk of connector and PCB pattern etc...

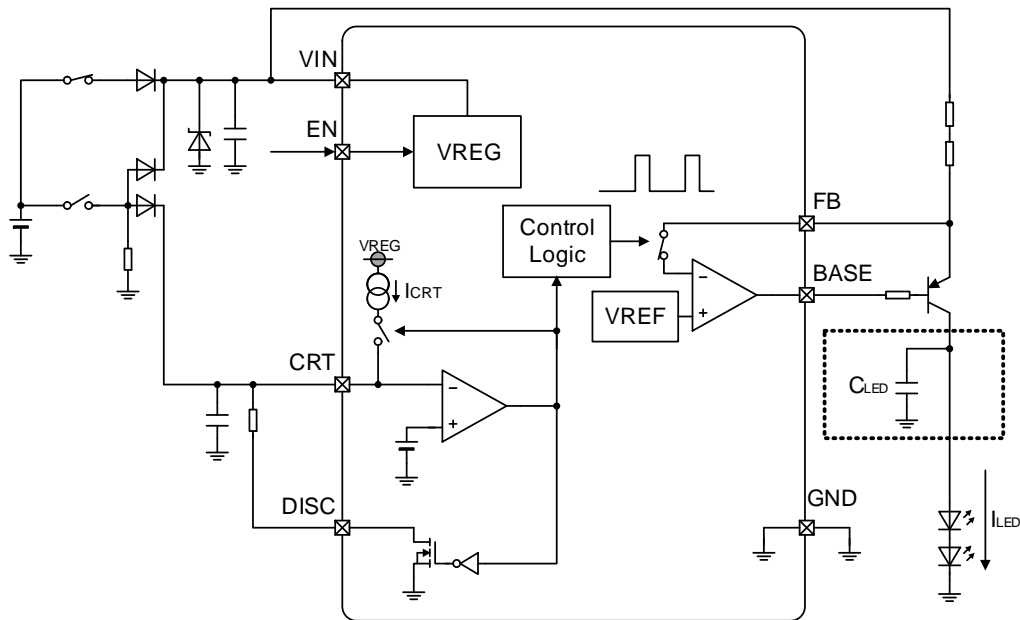

Figure 24. About the Capacitor of Connecting LED Anode

Description of Function – continued

Evaluation example (I_{LED} pulse width at PWM Dimming operation)

Condition: +B=13 V
 Ta=25 °C
 LED=1 Strings
 C_{CRT}=0.01 μF
 R_{DISC}=1.0 kΩ
 PWM Dimming Mode

PNP Tr. : 1parallel	I _{LED} =50 mA	I _{LED} =500 mA
C _{LED} =0.1 μF		
	Rise Time	Rise Time
	2.0μs	1.9μs
	Fall Time	Fall Time
	0.9μs	0.7μs
OverShoot	OverShoot	
≅ 0mA	1mA (0.2%)	
C _{LED} =0.47 μF		
	Rise Time	Rise Time
	7.4μs	4.4μs
	Fall Time	Fall Time
	5.3μs	2.5μs
OverShoot	OverShoot	
≅ 0mA	≅ 0mA	
PNP Tr. : 5parallel	I _{LED} =50 mA	I _{LED} =200 mA
C _{LED} =0.1 μF		
	Rise Time	Rise Time
	1.5μs	2.2μs
	Fall Time	Fall Time
	0.6μs	0.5μs
OverShoot	OverShoot	
22mA (4.4%)	10mA (1%)	
C _{LED} =0.47 μF		
	Rise Time	Rise Time
	2.8μs	2.4μs
	Fall Time	Fall Time
	1.4μs	0.8μs
OverShoot	OverShoot	
≅ 0mA	56mA (5.6%)	

Description of Function – continued

9. DC Dimming Function (DCDIM)

The IC provides DC dimming function to input DC voltage to the DCDIM pin like below schematic. The DCDIM pin is connecting the internal comparator which select the reference voltage of the DRVAMP reference voltage (V_{FBREG}). The V_{FBREG} is set by the DCDIM pin voltage when $V_{DCDIM} < V_{REG} \times 0.42$ and set by internal reference voltage when $V_{DCDIM} \geq V_{REG} \times 0.8$. V_{FBREG} can be set to 0.174 V to 1.378 V (Typ) by applying voltage at the V_{DCDIM} . An output current can be set by a resistor connected to a LED board for Luminous Flux group as below. In case of not using DC dimming function, the DCDIM pin needs to be connected to the VREG pin. Also if needed be measure for EMC, connect capacitor to the DCDIM pin.

The DC dimming function setting can be defined by the following formula:

$$V_{FBREG} (V_{DCDIM} < V_{REG} \times 0.5) = V_{DCDIM} \times D_{DG} - 0.08 \text{ [V]}$$

D_{DG} :DC Dimming Gain 730 mV/V(Typ)

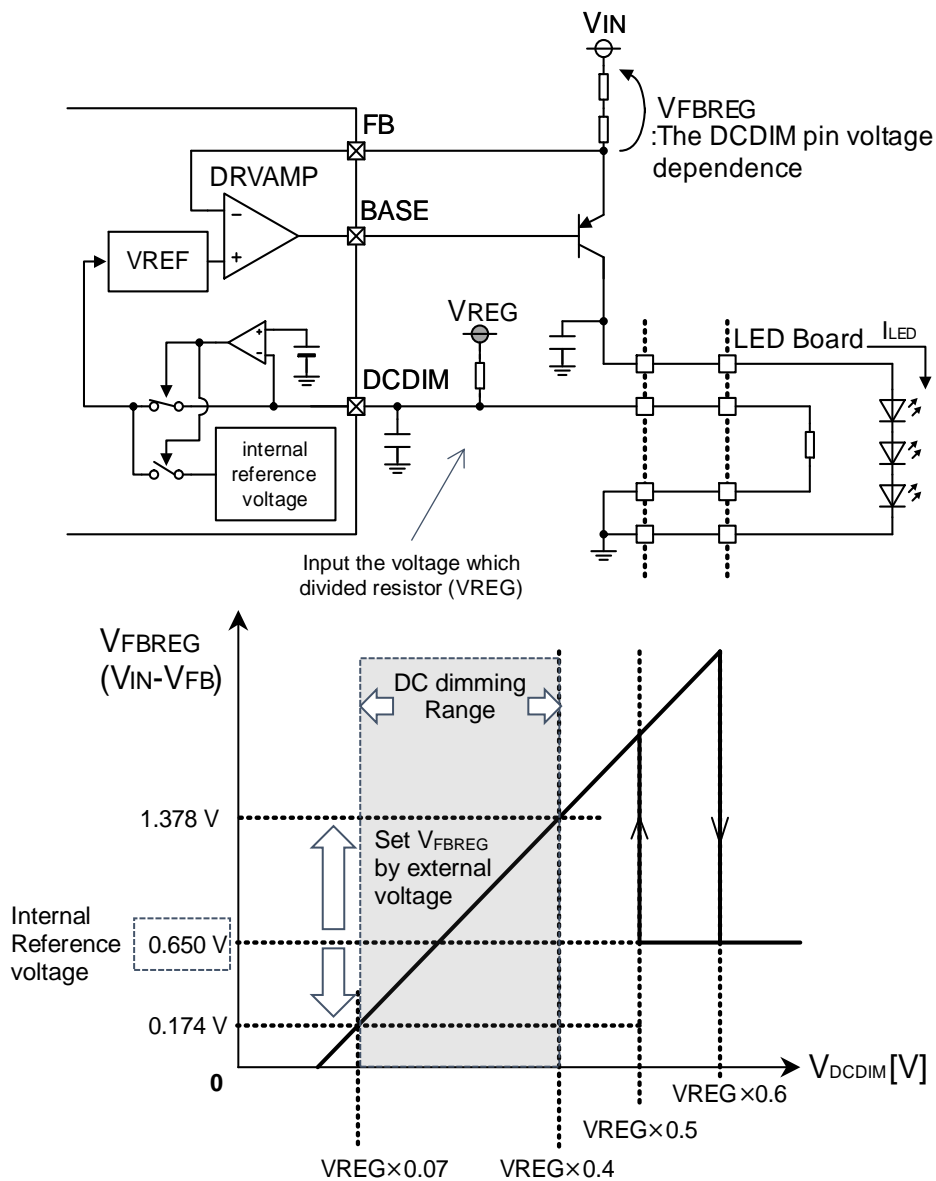

Figure 25. DC Dimming Function

Description of Function – continued

10. Thermal De-rating Function (THD)

The IC provides Thermal De-rating function to connect NTC Thermistor to the THD pin like below schematic. V_{FBREG} can be set to 0.174 V to 0.466 V (Typ) by applying voltage at the THD pin voltage.

To set NTC Thermistor value detect LED Board heat up and decrease the THD pin voltage. Output current is limited and prevent heat up. In case of not using THD function, the THD pin voltage needs to be connected to the VREG pin. Also if needed be measure for EMC, connect capacitor to the THD pin.

Steep changes in the THD pin voltage also might affect the ability of the output amplifier to keep up with the changes. So evaluate I_{LED} waveform on actual board.

The Thermal De-rating function can be defined by the following formula:

In case of not using DC Dimming

$$V_{FBREG} (V_{THD} < 1.0V) = V_{FBREG} - (1.0V - V_{THD}) \times D_{DG} \quad [V]$$

In case of using DC Dimming

$$V_{FBREG} (V_{THD} < V_{DCDIM}) = V_{FBREG} - (V_{DCDIM} - V_{THD}) \times D_{DG} \quad [V]$$

D_{DG} :DC Dimming Gain 730 mV/V(Typ)

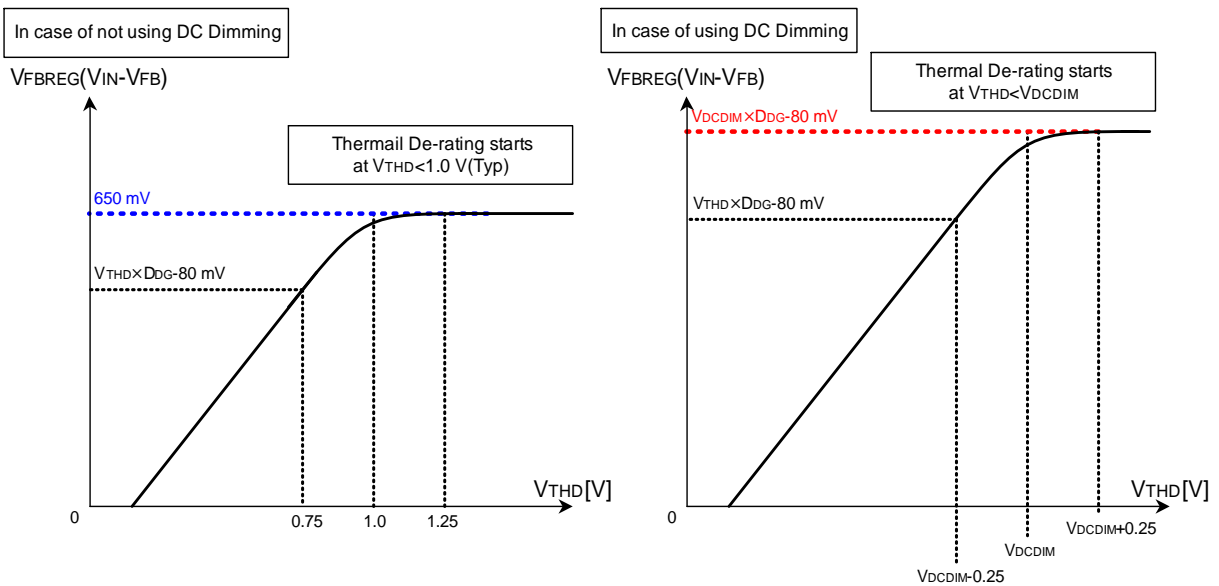
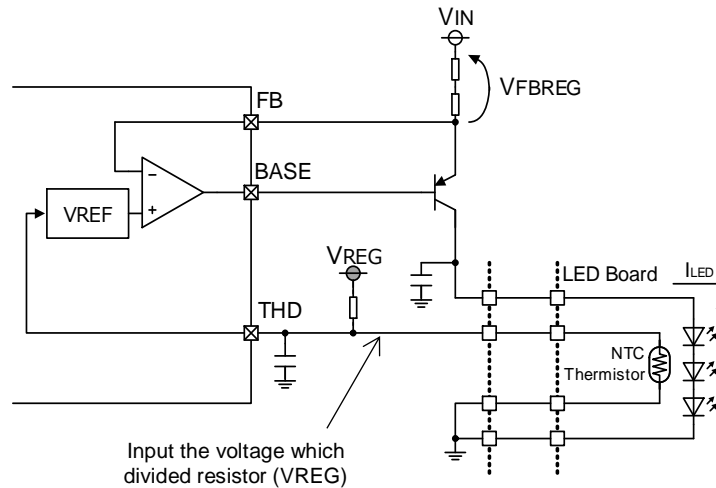

Figure 26. Thermal De-rating function

Description of Function – continued

11. PBUS Function

The PBUS pin is the pin to input and output an error signal. When abnormality such as LED open or output ground fault occurs, it can notify the abnormality to the outside by changing the PBUS pin output from high to low. In addition, by externally controlling the PBUS pin from high to low, the LED current is turned off. When using multiple LSIs to drive multiple LEDs, it is possible to turn off all LED lines at once by connecting the PBUS pins of each CH as shown in the figure below, even if LED open or output ground fault occurs.

Caution of using the PBUS pin

Do not connect to the PBUS pins other than BD1834xFV-M series due to the difference of ratings, internal threshold voltages, and so on.

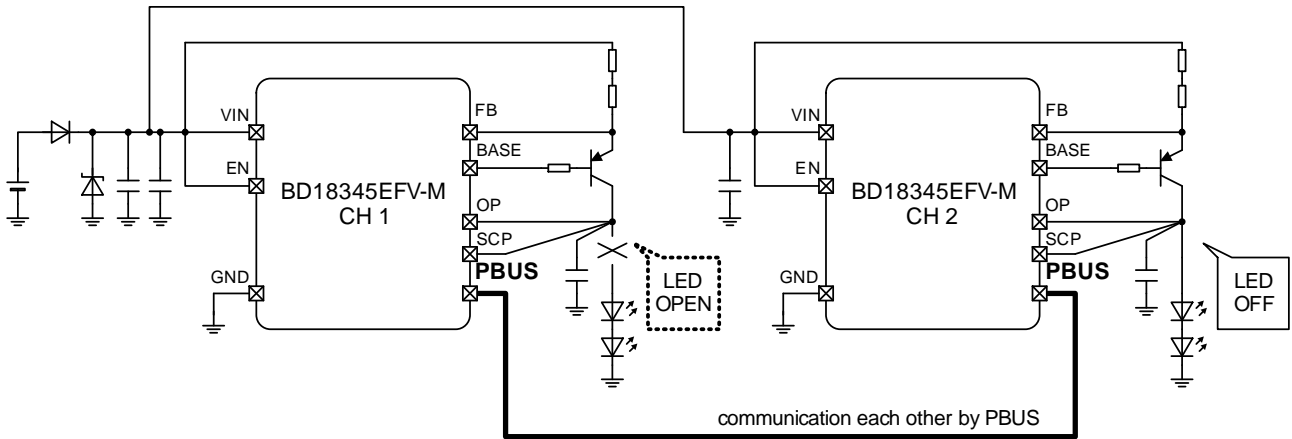

Figure 27. PBUS Function

▼ Example of Protective Operation due to LED Open Circuit

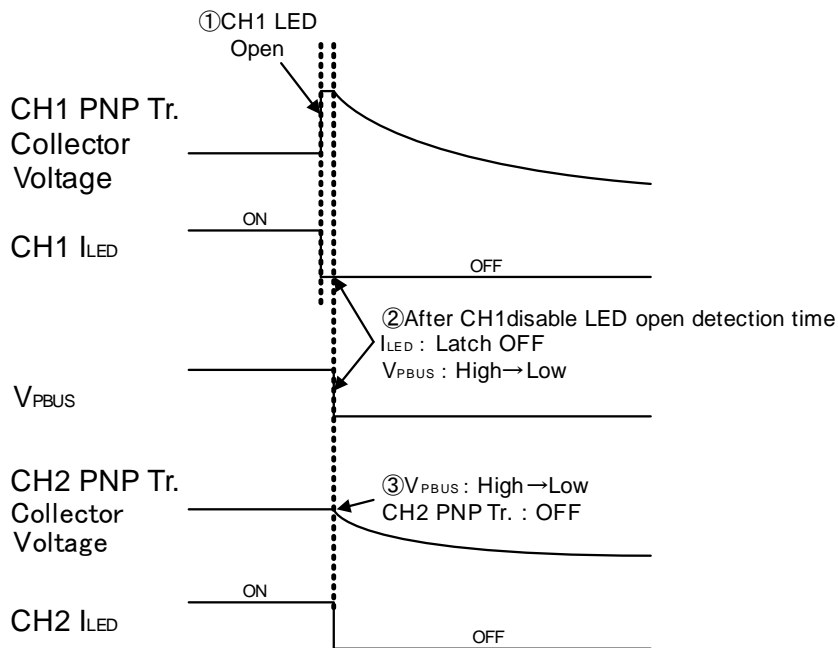

Figure 28. Example of Protective Operation

If LED OPEN occurs, the PBUS pin of CH1 is switched from High to Low output. As the PBUS pin becomes Low, LED drivers of other CH detect the condition and turns OFF their own LEDs. The collector voltage of PNP transistor clamps to 1.3 V (Typ) during the OFF period, in order to prohibit ground fault detection.

Description of Function – continued

12. Over Voltage Mute Function (OVM)

Once the VIN pin voltage (VIN) goes above 22.0 V (Typ), the over voltage mute function is activated to decrease the LED current (ILED) in order to suppress heat generation from the external PNP transistor. The FB pin voltage VFBREG which controls the LED current (ILED) will decay at -25 mV/V (Typ).

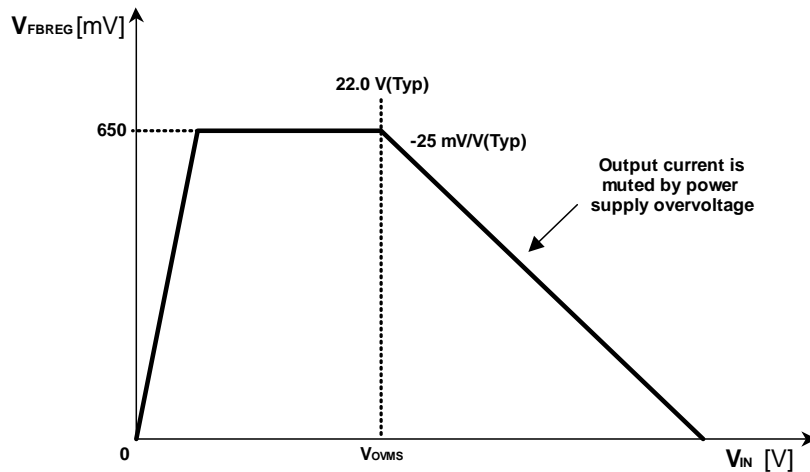
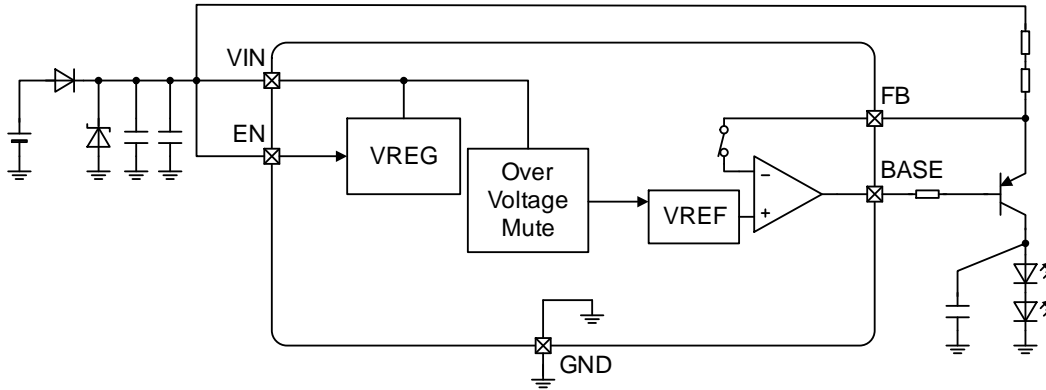

Figure 29. Over Voltage Mute Function (OVM)

13. Under Voltage Lockout (UVLO)

UVLO is a protection circuit to prevent malfunction of the IC when the power is turned on or when the power is suddenly shut off.

This IC has two UVLO circuits; UVLO VIN for VIN and UVLO VREG for VREG.

As soon as UVLO status is detected, the BASE pin sink current will be turned off and switch OFF the LED current (ILED). The following shows the threshold conditions of both UVLO circuits.

Operating Mode	Detection Conditions		LED Current (ILED)	PBUS Pin
	[Detect]	[Release]		
UVLO VIN	VIN ≤ 4.10 V (Typ)	VIN ≥ 4.50 V (Typ)	OFF (Note 1)	High
UVLO VREG	VREG ≤ 3.75 V (Typ)	VREG ≥ 4.00 V (Typ)	OFF (Note 1)	High

(Note 1) The BASE pin sink current is turned OFF to switch OFF the LED current (ILED).

Timing Chart

(Unless otherwise specified $T_a=25\text{ }^\circ\text{C}$, $V_{IN}=13\text{ V}$, PNP Transistor=2SAR573DFHG, LED 2 strings, and values are Typical.)

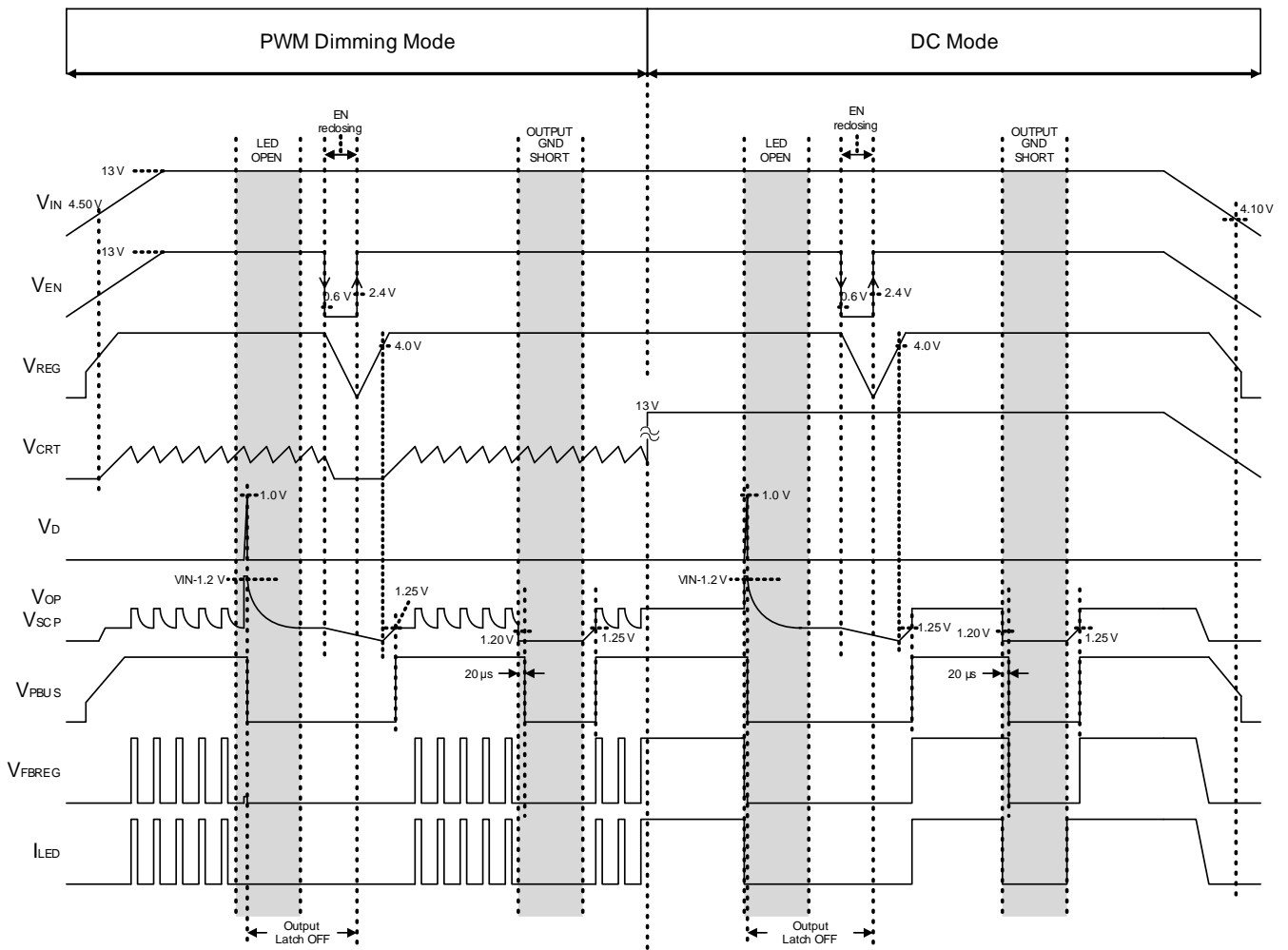

Figure 30. Timing Chart

Application Examples

(1) $I_{LED}=118\text{ mA}$, DC Dimming ($V_{DCDIM}=0.50\text{ V}$)

Figure 31. Application Example 1

Recommended Parts List 1

Parts	No	Parts Name	Value	Unit	Product Maker
IC	U1	BD18345EFV-M	-	-	ROHM
Diode	D1	RFN2LAM6STF	-	-	ROHM
	Z _{D1}	TND12H-220KB00AAA0	-	-	NIPPON CHEMICON
PNP Transistor	Q1	2SAR573DFHG	-	-	ROHM
Resistor	R _{FB1}	LTR10EVHFL1R20	1.2	Ω	ROHM
	R _{FB2}	LTR10EVHFL1R20	1.2	Ω	ROHM
	R _{OPM}	MCR03EZPFX3902	39	kΩ	ROHM
	R _{DCCIM1}	MCR03EZPFX4302	43	kΩ	ROHM
	R _{DCCIM2}	MCR03EZPFX4801	4.8	kΩ	ROHM
Capacitor	C _{VIN1}	GCM32ER71H475KA40	4.7	μF	murata
	C _{VIN2}	GCM155R71H104KE37	0.1	μF	murata
	C _{VREG}	GCM188R71E105KA49	1.0	μF	murata
	C _D	GCM155R11H103KA40	0.01	μF	murata
	C _{LED}	GCM155R71H104KE37	0.1	μF	murata

(Note 1) About Z_{D1}, place according to test standard of battery line.

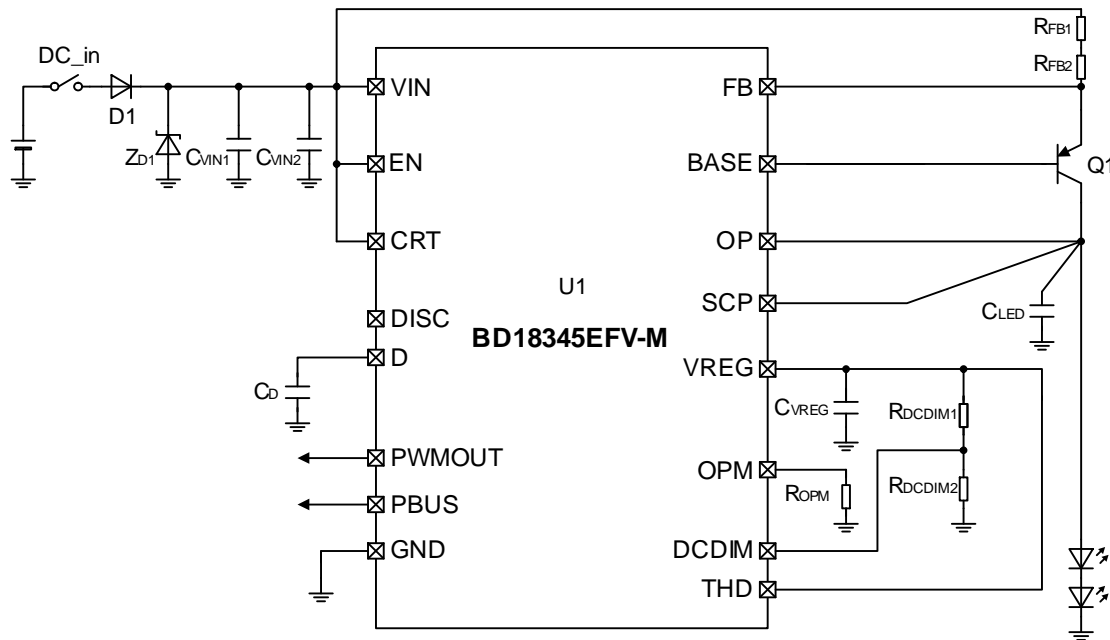
Note the following

1. External PNP transistor

For external PNP transistor, use the recommended device 2SAR573DFHG for this IC.

While using non-recommended device, validate the design on actual board with sufficient confirmation of the parts specifications (hfe, parasitic capacitance).

Check hfe of the part when designing base current limit resistor. (See Features Description, section 5). As for parasitic capacitance, the smaller it is, the smaller its overshoot is. Use devices that has smaller parasitic capacitance than that of recommended device. Also parasitic capacitance is possible to be varied by PCB layout so evaluate overshoot of I_{LED} on actual board. (See Features Description, Section 8 -Evaluation example, I_{LED} pulse width at PWM Dimming operation).

2. Power supply steep variation

This IC is validated with test conditions as per ISO7637-2 standards.

There is possibility of unexpected LED regulation (peak current of output etc.) due to sudden transients outside the specification range standards in input power supply. Check the maximum ratings of LED and evaluate on actual board for any unexpected LED regulation.

Application Examples - continued

(2) $I_{LED}=530\text{ mA}$, PWM ON Duty=10 %, DC Dimming ($V_{DCDIM}=0.75\text{ V}$), LED Thermal De-rating function

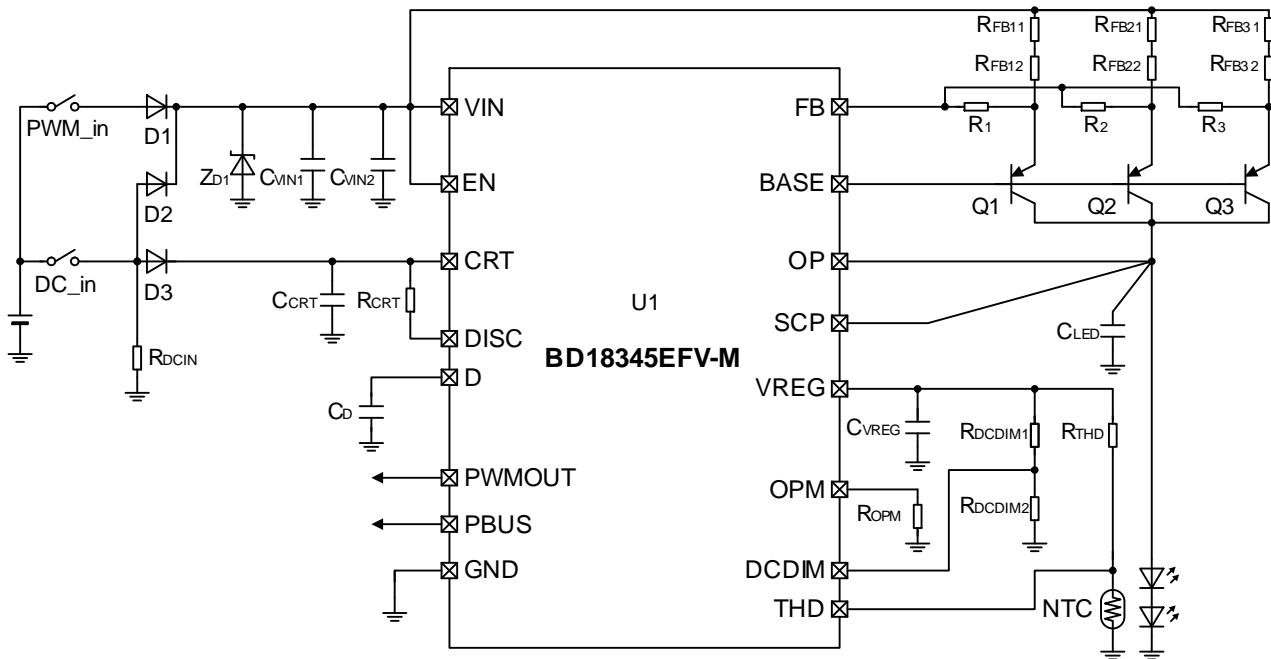

Figure 32. Application Example 2

Recommended Parts List 2

Parts	No	Parts Name	Value	Unit	Product Maker
IC	U1	BD18345EFV-M	-	-	ROHM
Diode	D1, D2	RFN2LAM6STF	-	-	ROHM
	D3	RFN1LAM6STF	-	-	ROHM
	Z _{D1}	TND12H-220KB00AAA0	-	-	NIPPON CHEMICON
PNP Transistor	Q1 to Q3	2SAR573DFHG	-	-	ROHM
Resistor	R _{FB11} to R _{FB31}	LTR10EVHFLR440	0.44	Ω	ROHM
	R _{FB12} to R _{FB32}	LTR10EVHFLR440	0.44	Ω	ROHM
	R _{CRT}	MCR03EZPFX3601	3.6	kΩ	ROHM
	R _{OPM}	MCR03EZPFX3902	39	kΩ	ROHM
	R _{DCDIM1}	MCR03EZPFX4302	43	kΩ	ROHM
	R _{DCDIM2}	MCR03EZPFX7601	7.6	kΩ	ROHM
	R _{THD}	MCR03EZPFX3902	39	kΩ	ROHM
	NTC	NTCG104KF104FT1S	100	kΩ	TDK
	R _{DCIN}	ESR10EZPF2001	2	kΩ	ROHM
Capacitor	C _{VIN1}	GCM32ER71H475KA40	4.7	μF	murata
	C _{VIN2}	GCM155R71H104KE37	0.1	μF	murata
	C _{VREG}	GCM188R71E105KA49	1.0	μF	murata
	C _{CRT}	GCM155R71H104KE37	0.1	μF	murata
	C _D	GCM155R11H103KA40	0.01	μF	murata
	C _{LED}	GCM155R71H104KE37	0.1	μF	murata

(Note 1) About Z_{D1}, place according to test standard of battery line.

Application Examples - continued

(3) $I_{LED}=150\text{ mA}$, Three Rows Drive, PWM ON Duty=10 %

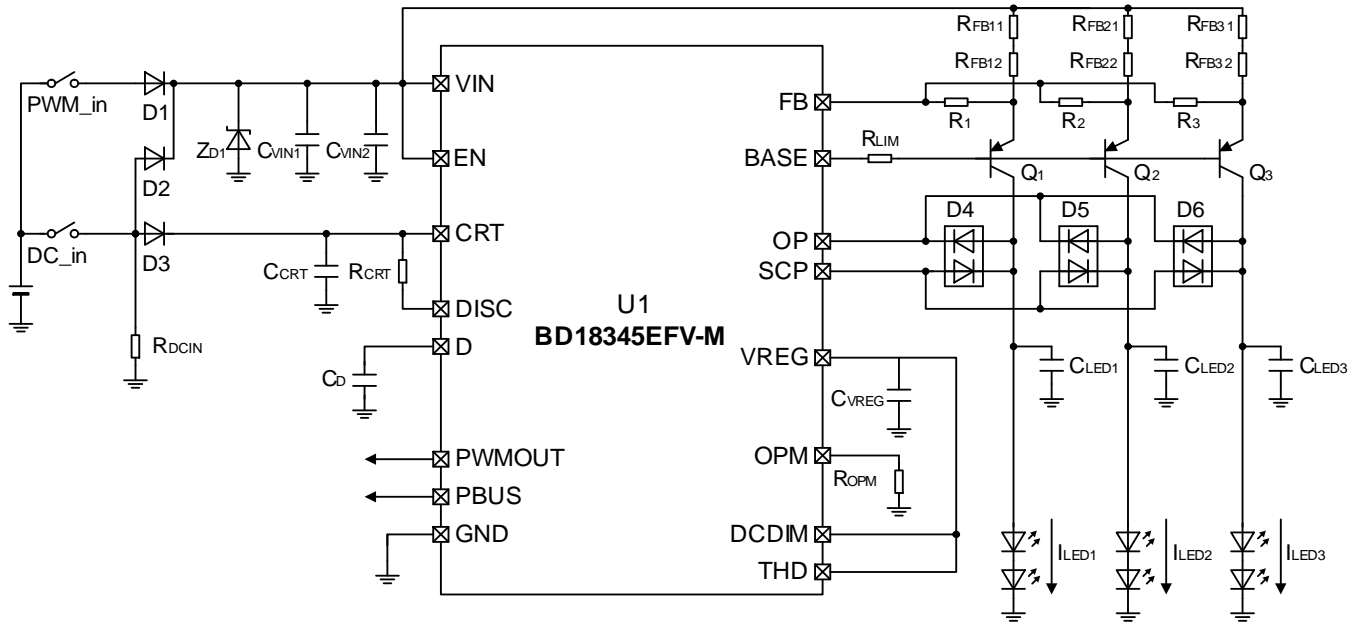

Figure 33. Application Example 3

Refer to Application Note of BD1834xFV-M series for details about the multiple rows drive such as the one above.

Power Dissipation

Thermal design should meet the following equation.

$$P_d > P_C$$

$$P_d = (1/\theta_{JA}) \times (T_{jmax} - T_a) \text{ or } (1/\Psi_{JT}) \times (T_{jmax} - T_T)$$

$$P_C = V_{IN} \times I_{VIN2} + V_{BASE} \times I_{BASE}$$

where:

P_d is the power dissipation.

P_C is the power consumption.

V_{IN} is the VIN pin voltage.

I_{VIN2} is the circuit current at normal mode.

V_{BASE} is the BASE pin voltage.

I_{BASE} is the BASE pin sink current.

θ_{JA} is the thermal resistance of junction to ambient.

Ψ_{JT} is the thermal characterization parameter of junction to center case surface.

T_{jmax} is the maximum junction temperature(150 °C).

T_a is the ambient temperature.

T_T is the case surface temperature.

I/O Equivalence Circuits

No.	Pin Name	I/O Equivalence Circuit	No.	Pin Name	I/O Equivalence Circuit
1	FB		11	OPM	
2	BASE		12	VREG	
3	N.C.				
4	OP		13	DCDIM	
5	SCP		14	D	
6	GND	-			
7	PBUS		15	CRT	
8	N.C.		16	DISC	
9	THD		17	N.C.	
10	PWM OUT		18	EN	
			19	N.C.	
			20	VIN	-

Operational Notes

1. Reverse Connection of Power Supply

Connecting the power supply in reverse polarity can damage the IC. Take precautions against reverse polarity when connecting the power supply, such as mounting an external diode between the power supply and the IC's power supply pins.

2. Power Supply Lines

Design the PCB layout pattern to provide low impedance supply lines. Furthermore, connect a capacitor to ground at all power supply pins. Consider the effect of temperature and aging on the capacitance value when using electrolytic capacitors.

3. Ground Voltage

Ensure that no pins are at a voltage below that of the ground pin at any time, even during transient condition.

4. Ground Wiring Pattern

When using both small-signal and large-current ground traces, the two ground traces should be routed separately but connected to a single ground at the reference point of the application board to avoid fluctuations in the small-signal ground caused by large currents. Also ensure that the ground traces of external components do not cause variations on the ground voltage. The ground lines must be as short and thick as possible to reduce line impedance.

5. Recommended Operating Conditions

The function and operation of the IC are guaranteed within the range specified by the recommended operating conditions. The characteristic values are guaranteed only under the conditions of each item specified by the electrical characteristics.

6. Inrush Current

When power is first supplied to the IC, it is possible that the internal logic may be unstable and inrush current may flow instantaneously due to the internal powering sequence and delays, especially if the IC has more than one power supply. Therefore, give special consideration to power coupling capacitance, power wiring, width of ground wiring, and routing of connections.

7. Testing on Application Boards

When testing the IC on an application board, connecting a capacitor directly to a low-impedance output pin may subject the IC to stress. Always discharge capacitors completely after each process or step. The IC's power supply should always be turned off completely before connecting or removing it from the test setup during the inspection process. To prevent damage from static discharge, ground the IC during assembly and use similar precautions during transport and storage.

8. Inter-pin Short and Mounting Errors

Ensure that the direction and position are correct when mounting the IC on the PCB. Incorrect mounting may result in damaging the IC. Avoid nearby pins being shorted to each other especially to ground, power supply and output pin. Inter-pin shorts could be due to many reasons such as metal particles, water droplets (in very humid environment) and unintentional solder bridge deposited in between pins during assembly to name a few.

9. Unused Input Pins

Input pins of an IC are often connected to the gate of a MOS transistor. The gate has extremely high impedance and extremely low capacitance. If left unconnected, the electric field from the outside can easily charge it. The small charge acquired in this way is enough to produce a significant effect on the conduction through the transistor and cause unexpected operation of the IC. So unless otherwise specified, unused input pins should be connected to the power supply or ground line.

Operational Notes – continued

10. Regarding the Input Pin of the IC

This monolithic IC contains P+ isolation and P substrate layers between adjacent elements in order to keep them isolated. P-N junctions are formed at the intersection of the P layers with the N layers of other elements, creating a parasitic diode or transistor. For example (refer to figure below):

When GND > Pin A and GND > Pin B, the P-N junction operates as a parasitic diode.
 When GND > Pin B, the P-N junction operates as a parasitic transistor.

Parasitic diodes inevitably occur in the structure of the IC. The operation of parasitic diodes can result in mutual interference among circuits, operational faults, or physical damage. Therefore, conditions that cause these diodes to operate, such as applying a voltage lower than the GND voltage to an input pin (and thus to the P substrate) should be avoided.

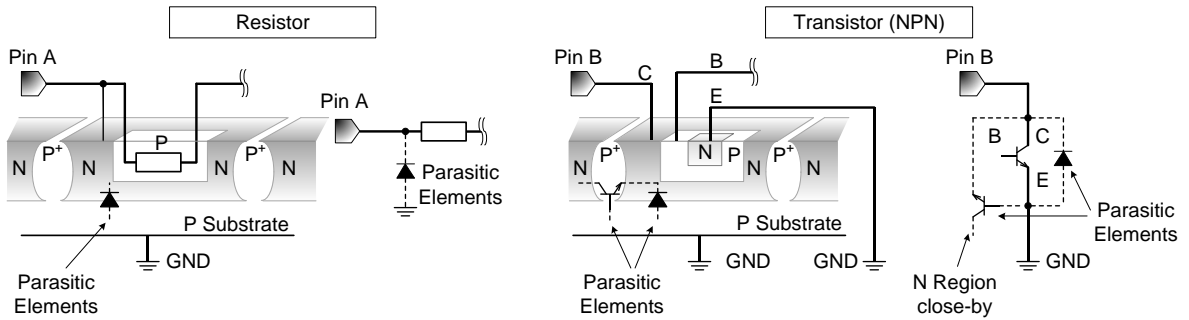

Figure 34. Example of Monolithic IC Structure

11. Ceramic Capacitor

When using a ceramic capacitor, determine a capacitance value considering the change of capacitance with temperature and the decrease in nominal capacitance due to DC bias and others.

12. Thermal Shutdown Circuit (TSD)

This IC has a built-in thermal shutdown circuit that prevents heat damage to the IC. Normal operation should always be within the IC's maximum junction temperature rating. If however the rating is exceeded for a continued period, the junction temperature (T_j) will rise which will activate the TSD circuit that will turn OFF power output pins. When the T_j falls below the TSD threshold, the circuits are automatically restored to normal operation.

Note that the TSD circuit operates in a situation that exceeds the absolute maximum ratings and therefore, under no circumstances, should the TSD circuit be used in a set design or for any purpose other than protecting the IC from heat damage.

Ordering Information

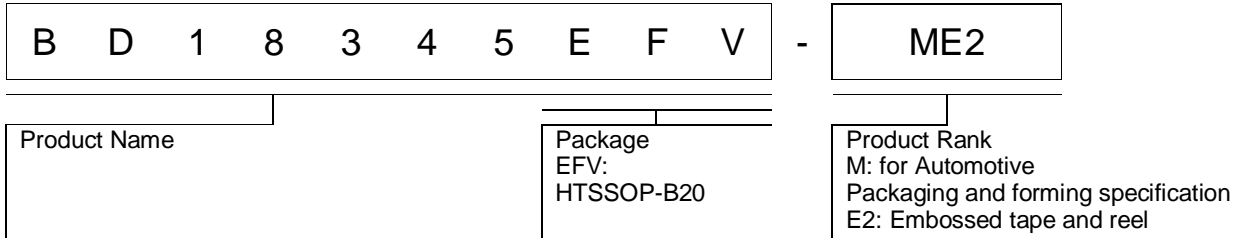

Marking Diagram

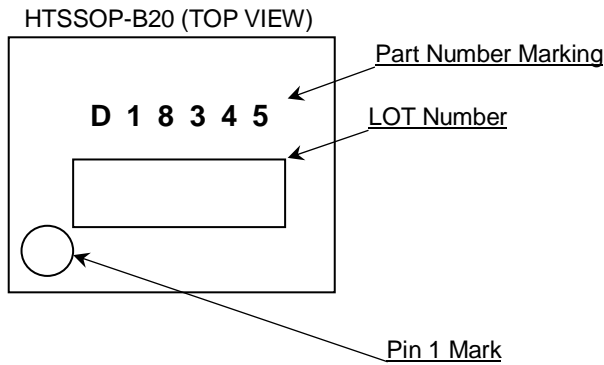

Physical Dimension and Packing Information

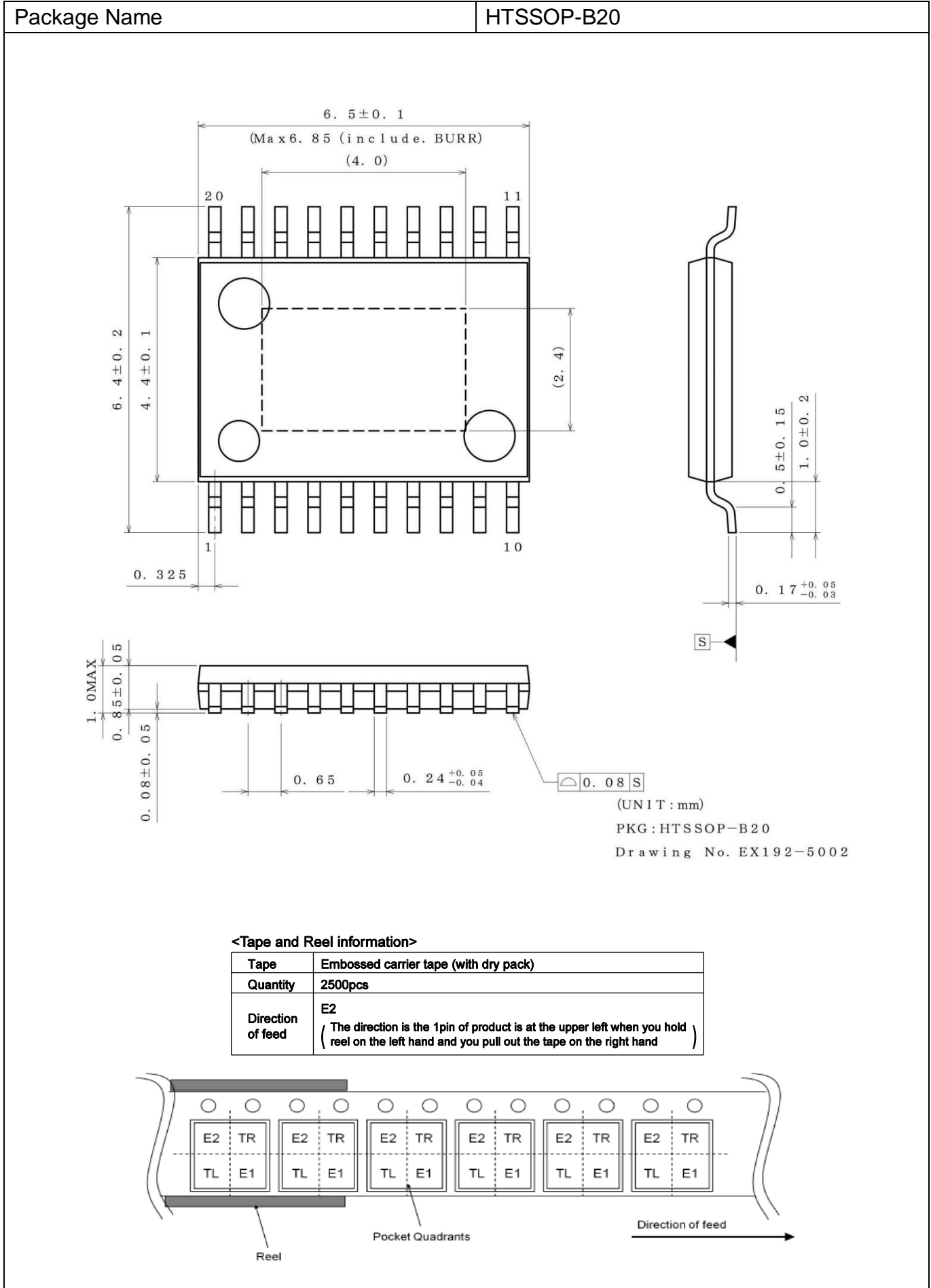

Revision History

Date	Revision	Changes
21.Sep.2018	001	New Release

Notice

Precaution on using ROHM Products

1. If you intend to use our Products in devices requiring extremely high reliability (such as medical equipment ^(Note 1), aircraft/spacecraft, nuclear power controllers, etc.) and whose malfunction or failure may cause loss of human life, bodily injury or serious damage to property ("Specific Applications"), please consult with the ROHM sales representative in advance. Unless otherwise agreed in writing by ROHM in advance, ROHM shall not be in any way responsible or liable for any damages, expenses or losses incurred by you or third parties arising from the use of any ROHM's Products for Specific Applications.

(Note1) Medical Equipment Classification of the Specific Applications

JAPAN	USA	EU	CHINA
CLASS III	CLASS III	CLASS II b	CLASS III
CLASS IV		CLASS III	

2. ROHM designs and manufactures its Products subject to strict quality control system. However, semiconductor products can fail or malfunction at a certain rate. Please be sure to implement, at your own responsibilities, adequate safety measures including but not limited to fail-safe design against the physical injury, damage to any property, which a failure or malfunction of our Products may cause. The following are examples of safety measures:
 - [a] Installation of protection circuits or other protective devices to improve system safety
 - [b] Installation of redundant circuits to reduce the impact of single or multiple circuit failure
3. Our Products are not designed under any special or extraordinary environments or conditions, as exemplified below. Accordingly, ROHM shall not be in any way responsible or liable for any damages, expenses or losses arising from the use of any ROHM's Products under any special or extraordinary environments or conditions. If you intend to use our Products under any special or extraordinary environments or conditions (as exemplified below), your independent verification and confirmation of product performance, reliability, etc, prior to use, must be necessary:
 - [a] Use of our Products in any types of liquid, including water, oils, chemicals, and organic solvents
 - [b] Use of our Products outdoors or in places where the Products are exposed to direct sunlight or dust
 - [c] Use of our Products in places where the Products are exposed to sea wind or corrosive gases, including Cl₂, H₂S, NH₃, SO₂, and NO₂
 - [d] Use of our Products in places where the Products are exposed to static electricity or electromagnetic waves
 - [e] Use of our Products in proximity to heat-producing components, plastic cords, or other flammable items
 - [f] Sealing or coating our Products with resin or other coating materials
 - [g] Use of our Products without cleaning residue of flux (Exclude cases where no-clean type fluxes is used. However, recommend sufficiently about the residue.); or Washing our Products by using water or water-soluble cleaning agents for cleaning residue after soldering
 - [h] Use of the Products in places subject to dew condensation
4. The Products are not subject to radiation-proof design.
5. Please verify and confirm characteristics of the final or mounted products in using the Products.
6. In particular, if a transient load (a large amount of load applied in a short period of time, such as pulse, is applied, confirmation of performance characteristics after on-board mounting is strongly recommended. Avoid applying power exceeding normal rated power; exceeding the power rating under steady-state loading condition may negatively affect product performance and reliability.
7. De-rate Power Dissipation depending on ambient temperature. When used in sealed area, confirm that it is the use in the range that does not exceed the maximum junction temperature.
8. Confirm that operation temperature is within the specified range described in the product specification.
9. ROHM shall not be in any way responsible or liable for failure induced under deviant condition from what is defined in this document.

Precaution for Mounting / Circuit board design

1. When a highly active halogenous (chlorine, bromine, etc.) flux is used, the residue of flux may negatively affect product performance and reliability.
2. In principle, the reflow soldering method must be used on a surface-mount products, the flow soldering method must be used on a through hole mount products. If the flow soldering method is preferred on a surface-mount products, please consult with the ROHM representative in advance.

For details, please refer to ROHM Mounting specification

Precautions Regarding Application Examples and External Circuits

1. If change is made to the constant of an external circuit, please allow a sufficient margin considering variations of the characteristics of the Products and external components, including transient characteristics, as well as static characteristics.
2. You agree that application notes, reference designs, and associated data and information contained in this document are presented only as guidance for Products use. Therefore, in case you use such information, you are solely responsible for it and you must exercise your own independent verification and judgment in the use of such information contained in this document. ROHM shall not be in any way responsible or liable for any damages, expenses or losses incurred by you or third parties arising from the use of such information.

Precaution for Electrostatic

This Product is electrostatic sensitive product, which may be damaged due to electrostatic discharge. Please take proper caution in your manufacturing process and storage so that voltage exceeding the Products maximum rating will not be applied to Products. Please take special care under dry condition (e.g. Grounding of human body / equipment / solder iron, isolation from charged objects, setting of Ionizer, friction prevention and temperature / humidity control).

Precaution for Storage / Transportation

1. Product performance and soldered connections may deteriorate if the Products are stored in the places where:
 - [a] the Products are exposed to sea winds or corrosive gases, including Cl₂, H₂S, NH₃, SO₂, and NO₂
 - [b] the temperature or humidity exceeds those recommended by ROHM
 - [c] the Products are exposed to direct sunshine or condensation
 - [d] the Products are exposed to high Electrostatic
2. Even under ROHM recommended storage condition, solderability of products out of recommended storage time period may be degraded. It is strongly recommended to confirm solderability before using Products of which storage time is exceeding the recommended storage time period.
3. Store / transport cartons in the correct direction, which is indicated on a carton with a symbol. Otherwise bent leads may occur due to excessive stress applied when dropping of a carton.
4. Use Products within the specified time after opening a humidity barrier bag. Baking is required before using Products of which storage time is exceeding the recommended storage time period.

Precaution for Product Label

A two-dimensional barcode printed on ROHM Products label is for ROHM's internal use only.

Precaution for Disposition

When disposing Products please dispose them properly using an authorized industry waste company.

Precaution for Foreign Exchange and Foreign Trade act

Since concerned goods might be fallen under listed items of export control prescribed by Foreign exchange and Foreign trade act, please consult with ROHM in case of export.

Precaution Regarding Intellectual Property Rights

1. All information and data including but not limited to application example contained in this document is for reference only. ROHM does not warrant that foregoing information or data will not infringe any intellectual property rights or any other rights of any third party regarding such information or data.
2. ROHM shall not have any obligations where the claims, actions or demands arising from the combination of the Products with other articles such as components, circuits, systems or external equipment (including software).
3. No license, expressly or implied, is granted hereby under any intellectual property rights or other rights of ROHM or any third parties with respect to the Products or the information contained in this document. Provided, however, that ROHM will not assert its intellectual property rights or other rights against you or your customers to the extent necessary to manufacture or sell products containing the Products, subject to the terms and conditions herein.

Other Precaution

1. This document may not be reprinted or reproduced, in whole or in part, without prior written consent of ROHM.
2. The Products may not be disassembled, converted, modified, reproduced or otherwise changed without prior written consent of ROHM.
3. In no event shall you use in any way whatsoever the Products and the related technical information contained in the Products or this document for any military purposes, including but not limited to, the development of mass-destruction weapons.
4. The proper names of companies or products described in this document are trademarks or registered trademarks of ROHM, its affiliated companies or third parties.

General Precaution

1. Before you use our Products, you are requested to carefully read this document and fully understand its contents. ROHM shall not be in any way responsible or liable for failure, malfunction or accident arising from the use of any ROHM's Products against warning, caution or note contained in this document.
2. All information contained in this document is current as of the issuing date and subject to change without any prior notice. Before purchasing or using ROHM's Products, please confirm the latest information with a ROHM sales representative.
3. The information contained in this document is provided on an "as is" basis and ROHM does not warrant that all information contained in this document is accurate and/or error-free. ROHM shall not be in any way responsible or liable for any damages, expenses or losses incurred by you or third parties resulting from inaccuracy or errors of or concerning such information.

X-ON Electronics

Largest Supplier of Electrical and Electronic Components

Click to view similar products for [LED Lighting Drivers](#) category:

Click to view products by [ROHM](#) manufacturer:

Other Similar products are found below :

[LV5235V-MPB-H](#) [MB39C602PNF-G-JNEFE1](#) [MIC2871YMK-T5](#) [AL1676-10BS7-13](#) [AL1676-20AS7-13](#) [AP5726WUG-7](#) [ICL8201](#)
[IS31BL3228B-UTLS2-TR](#) [IS31BL3506B-TTLS2-TR](#) [AL3157F-7](#) [AP5725FDCG-7](#) [LV52204MTTBG](#) [AP5725WUG-7](#) [STP4CMPQTR](#)
[NCL30086BDR2G](#) [CAT4004BHU2-GT3](#) [LV52207AXA-VH](#) [AP1694AS-13](#) [TLE4242EJ](#) [AS3688](#) [IS31LT3172-GRLS4-TR](#) [TLD2311EL](#)
[KTD2694EDQ-TR](#) [KTZ8864EJAA-TR](#) [IS32LT3174-GRLA3-TR](#) [MP2488DN-LF-Z](#) [NLM0010XTSA1](#) [AL1676-20BS7-13](#)
[ZXLD1370QESTTC](#) [MPQ7220GF-AEC1-P](#) [MPQ7220GR-AEC1-P](#) [MPQ4425BGJ-AEC1-P](#) [MPQ7220GF-AEC1-Z](#) [MPQ7220GR-AEC1-Z](#)
[MPQ4425BGJ-AEC1-Z](#) [IS31FL3737B-QFLS4-TR](#) [IS31FL3239-QFLS4-TR](#) [KTD2058EUAC-TR](#) [KTD2037EWE-TR](#) [DIO5662ST6](#)
[IS31BL3508A-TTLS2-TR](#) [KTD2026BEWE-TR](#) [MAX20052CATC/V+](#) [MAX25606AUP/V+](#) [BD6586MUV-E2](#) [BD9206EFV-E2](#) [BD9416FS-](#)
[E2](#) [LYT4227E](#) [LYT6079C-TL](#) [MP3394SGF-P](#)