

1ch Low Side Switch IC

In-Vehicle 1ch Low Side Switch

BD1LB500 Series (BD1LB500EFJ-C BD1LB500FVM-C)

Features

- Built-in overcurrent limiting circuit
 - Built-in thermal shutdown circuit (TSD)
 - Built-in open load detection circuit (at output OFF)
 - Enables direct control from CMOS logic ICs, etc.
 - Low standby current
 - Built-in under voltage lock out circuit
 - Built-in diagnostic output (ST) terminal
 - Low ON resistance $R_{DS(ON)}=350m\Omega(Typ)$ ($V_{DD}=IN=5V$, $T_a=25^\circ C$, $I_{OUT}=0.25A$)
 - Built-in overvoltage protection(active clamp) for output circuit
 - Monolithic power IC in which the control unit (CMOS) and power MOS FET are incorporated into one chip
 - 1ch low side switch for driving mechanical relay coil
 - AEC-Q100 Qualified⁽¹⁾
- (1) Grade1

Specifications

Operating voltage range	3.5V to 5.5V
ON resistance (25°C, Typ.)	350mΩ
Overcurrent limitation (Typ.)	1.50A
Active clamp energy (25°C)	25mJ

Package

HTSOP-J8	4.90mm x 6.00mm x 1.00mm
MSOP8	2.90mm x 4.00mm x 0.90mm

Overview

BD1LB500 Series is an in-vehicle 1ch low side switch. This switch builds in the overcurrent limiting circuit, thermal shutdown circuit, open load detection circuit and under voltage lock out circuit. It also provides the diagnostic output circuit when an abnormality is detected.

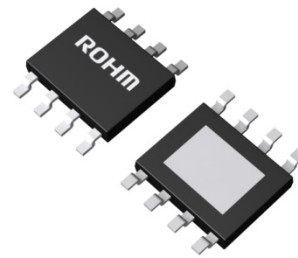

HTSOP-J8



MSOP8

Application

- In-vehicle application (Air conditioners, body devices, meters, etc.)

Basic Application Circuit (Recommendation)

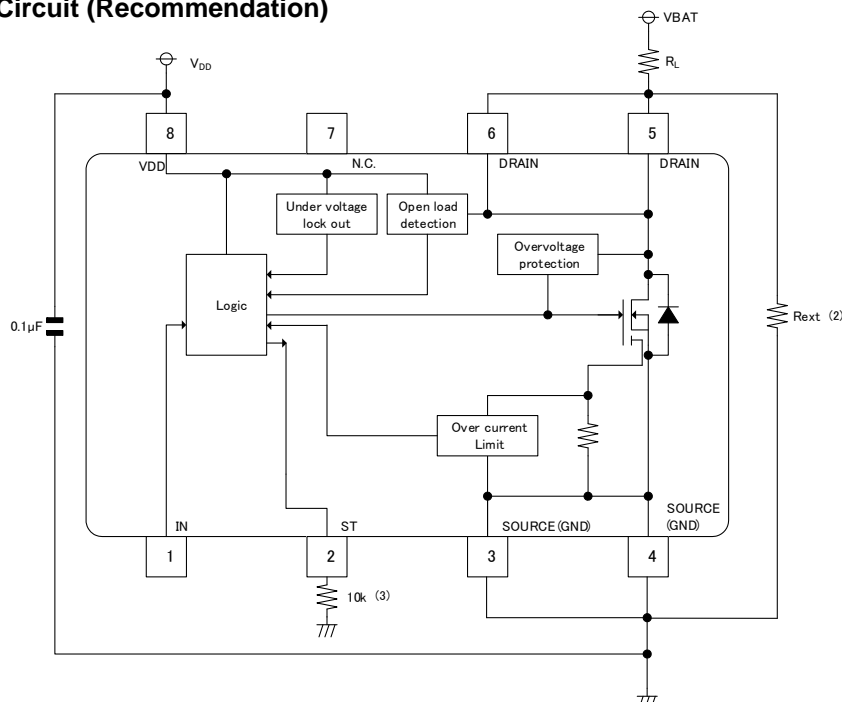

(2) When the open detection function is required, an external resistance must be added between DRAIN terminal and SOURCE terminal.
 (3) It is necessary to detect unusual state(ST terminal is low) when VDD terminal is opened. When ST pin is not used, it can be open.

○Product configuration: Silicon monolithic integrated circuit ○The product is not designed for radiation resistance.

Pin Descriptions

Pin No.	Symbol	Function
1	IN	Input terminal; a pull down resistor is connected internally.
2	ST	Self-diagnostic output terminal; outputs "L" at detection of overcurrent, at open (IN=0V), and in the overheat state. See the truth table. It is structured as COMS inverter output circuit.
3,4	SOURCE (GND)	Ground terminal
5,6	DRAIN	Output terminal; limits output current to protect IC when load is short-circuited and current exceeding the overcurrent detection value (0.8A Min) flows to the output terminal.
7	N.C.	No Connect pin
8	VDD	Power supply terminal
Cooling Tab ⁽¹⁾	TAB	The heat radiation metal on the substrate is connected to the IC sub. Therefore, connect Cooling Tab to the external GND electrical potential (for HTSOP-J8 only).

(1)MSOP8 does not have Cooling Tab.

Pin Configurations

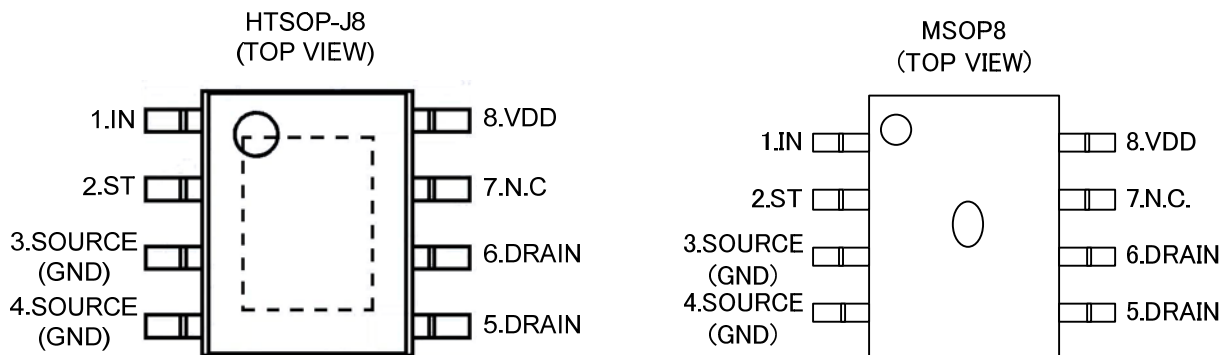

Product Name	PKG	TSD function	ON resistance (25°C, Typ)
BD1LB500EFJ-C	HTSOP-J8	Self-restart	350mΩ
BD1LB500FVM-C	MSOP8		

Absolute Maximum Ratings

Item	Symbol	Limit values	Unit
DRAIN-SOURCE voltage	V_{DS}	42 (internally limited)	V
Power supply voltage	V_{DD}	7	V
Diagnostic output voltage	V_{ST}	-0.3 to +7 ⁽¹⁾	V
Output current (DC)	I_{OD}	0.8 ⁽²⁾	A
Output current (Pulse)	I_{OP}	Internally limited ⁽³⁾	A
Input voltage	V_{IN}	-0.3 to +7 ⁽¹⁾	V
Power consumption	P_d	2.1(HTSOP-J8) ⁽⁴⁾	W
		0.587(MSOP8) ⁽⁵⁾	
Operating temperature range	T_{opr}	-40 $\leq T_{opr}$ < +150	°C
Storage temperature range	T_{stg}	-55 to +150	°C
Maximum junction temperature	T_{jmax}	150	°C
Active clamp energy (single pulse)	$E_{AS(25^\circ C)}$	25 ⁽⁶⁾	mJ
	$E_{AS(150^\circ C)}$	25 ⁽⁷⁾⁽⁸⁾	mJ

Operating Voltage Ratings

Item	Code	Limit values	Unit
Operating voltage range	V_{DD}	3.5 to 5.5	V

- (1) The condition, $V_{DD} > V_{IN}$, V_{ST} is required.
- (2) The value must not exceed P_d .
- (3) Internally limited by the overcurrent limiting circuit.
- (4) When mounting PCB (70×70[mm], thickness 1.6[mm], copper foil area 70×70[mm], glass epoxy 2-layer substrate).
When using at $T_a \geq 25^\circ C$, power dissipation is reduced at 16.8mW/°C.
- (5) When mounting PCB (70×70[mm], thickness 1.6[mm], copper foil area is Footprint only, glass epoxy single-layer substrate).
When using at $T_a \geq 25^\circ C$, power dissipation is reduced at 4.7mW/°C.
- (6) Active clamp energy at $T_{j(0)} = 25^\circ C$, using single non-repetitive pulse of 0.4A
- (7) Active clamp energy at $T_{j(0)} = 150^\circ C$, using single non-repetitive pulse of 0.4A
- (8) Not 100% tested.

Heat Dissipation Characteristics

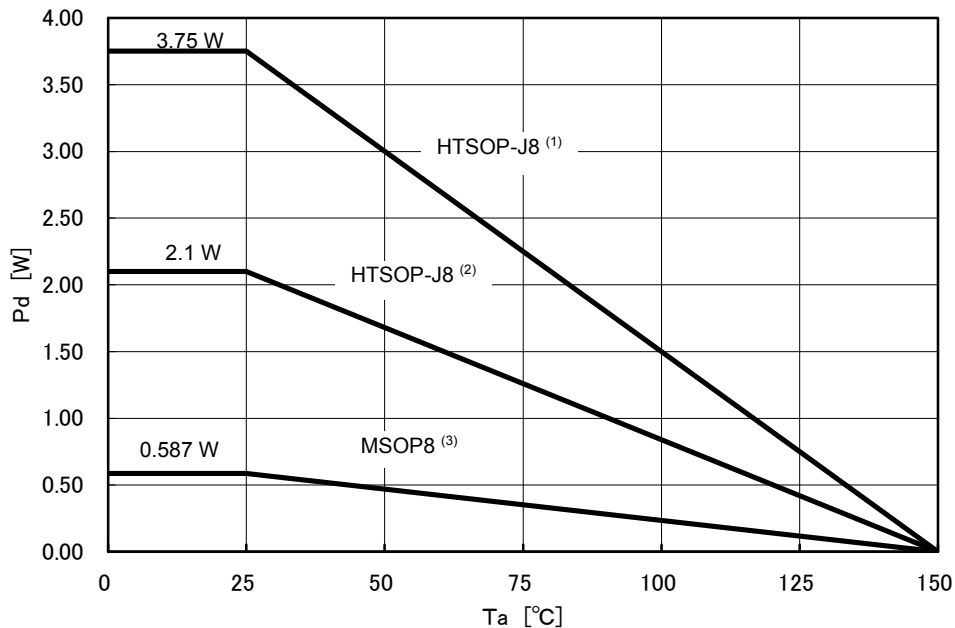

- (HTSOP-J8) (1) When mounting PCB (70×70[mm], thickness 1.6[mm], copper foil area 70×70[mm], glass epoxy 4-layer substrate)
When using at $T_a \geq 25^\circ C$, power dissipation is reduced at 30mW/°C.
- (2) When mounting PCB (70×70[mm], thickness 1.6[mm], copper foil area 70×70[mm], glass epoxy 2-layer substrate)
When using at $T_a \geq 25^\circ C$, power dissipation is reduced at 16.8mW/°C.
- (MSOP8) (3) When mounting PCB (70×70[mm], thickness 1.6[mm], copper foil area is Footprint only, glass epoxy single-layer substrate)
When using at $T_a \geq 25^\circ C$, power dissipation is reduced at 4.7mW/°C.

Electrical Characteristics ($V_{DD}=3.5V$ to $5.5V$, $-40^{\circ}C \leq T_j \leq +150^{\circ}C$ unless otherwise is specified)

Item	Symbol	Limit values			Unit	Condition
		Min	Typ	Max		
[Power Supply Block]						
Standby current	I_{DDs}	—	0	10	μA	$V_{DD}=5V, V_{IN}=0V, V_B=12V, R_L=47\Omega$
Operating current	I_{DD}	—	0.5	1.0	mA	$V_{DD}=5V, V_{IN}=5V, V_B=12V, R_L=47\Omega$
Under voltage lock out threshold voltage	V_{UVLO}	—	2.5	3.0	V	
[Input Block]						
H level input voltage	V_{TH1}	—	—	$V_{DD} \times 0.8$	V	
L level input voltage	V_{TH2}	$V_{DD} \times 0.2$	—	—	V	
Input hysteresis	V_{HYS}	—	0.40	—	V	
High level input current	I_{INH1}	—	50	100	μA	$V_{IN}=5V$
Low level input current	I_{INL}	-1	0	1	μA	$V_{IN}=0V$
[Power MOS output]						
Output ON resistance	$R_{DS(ON)}$	—	350	450	m Ω	$V_{IN}=5V, V_{DD}=5V, I_D=0.25A, T_j=25^{\circ}C$
	$R_{DS(ON)}$	—	570	750	m Ω	$V_{IN}=5V, V_{DD}=5V, I_D=0.25A, T_j=150^{\circ}C$
Output leak current	$I_{L(OFF)}$	—	—	10	μA	$V_{IN}=0V, V_{DS}=12V, T_j=25^{\circ}C$
	$I_{L(OFF)}$	—	—	100	μA	$V_{IN}=0V, V_{DS}=12V, T_j=150^{\circ}C$
Switching time	t_{ON}	—	20	40	μs	$V_{DD}=5V, V_{IN}=0V/5V, R_L=47\Omega$
	t_{OFF}	—	20	40	μs	$V_{DD}=5V, V_{IN}=0V/5V, R_L=47\Omega$
Slew rate (at ON)	dV/dt_{ON}	0.5	1	2	V/ μs	$V_{DD}=5V, V_{IN}=0V/5V, R_L=47\Omega$
Slew rate (at OFF)	$-dV/dt_{OFF}$	0.5	1	2	V/ μs	$V_{DD}=5V, V_{IN}=0V/5V, R_L=47\Omega$
Output clamp voltage	V_{CL}	42	47	52	V	$V_{IN}=0V, I_{OUT}=-1mA$
[Diagnostic output]						
Diagnostic output voltage "L level"	V_{STL}	—	—	0.4	V	$V_{DD}=5V, V_{IN}=5V, I_{ST}=0.1mA$
Diagnostic output voltage "H level"	V_{STH}	4.88	—	—	V	$V_{DD}=5V, V_{IN}=0V, I_{ST}=-0.1mA$
Diagnostic output current "H level"	I_{STH}	—	—	10	μA	$V_{IN}=0V, V_{ST}=5.5V$

Electrical Characteristics ($V_{DD}=3.5V$ to $5.5V$, $-40^{\circ}C \leq T_j \leq +150^{\circ}C$ unless otherwise is specified)

Item	Symbol	Rated value			Unit	Condition
		Min	Typ	Max		
[Protective circuit]						
Overcurrent detection current	I_{OCP}	0.8	1.5	2.5	A	$V_{IN}=5V$
Diagnostic output delay time	t_{DHL}	—	40	80	μs	$V_{DD}=5V, R_L=4\Omega$ to ∞
	t_{DLH}	—	320	640	μs	$V_{DD}=5V, R_L=\infty$ to 4Ω
Open load detection threshold voltage ⁽¹⁾	V_{OPEN}	1	2	3	V	$I_N=0V$
Open load detection time	t_{OPEN}	100	300	900	μs	$I_N=0V$

(1) To enable detection, an external resistance must be added between DRAIN terminal and SOURCE terminal.
(Determine R_{ext} depending on R_L .)

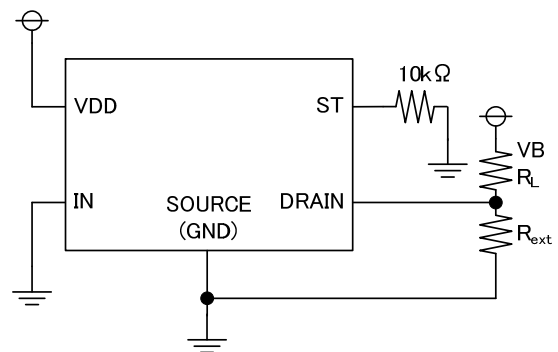

Definition

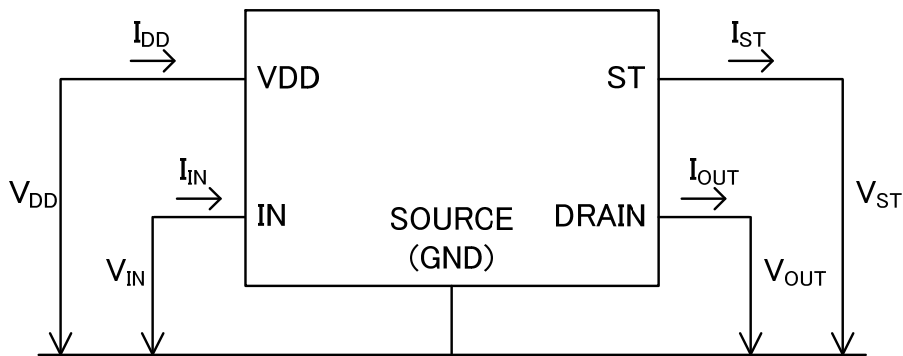

Figure 1. Definition

Measuring Circuit Diagram

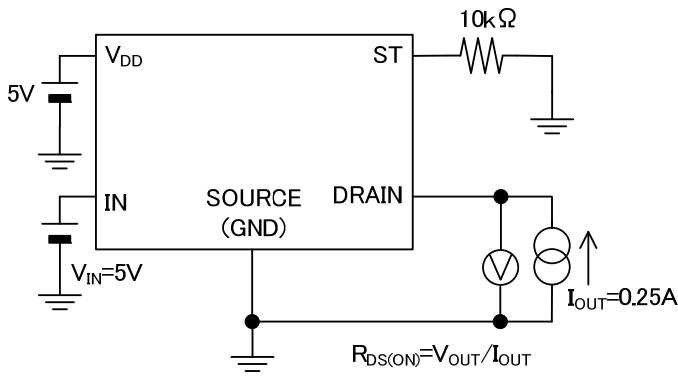

Figure 2. Output ON Resistance Measuring Circuit Diagram

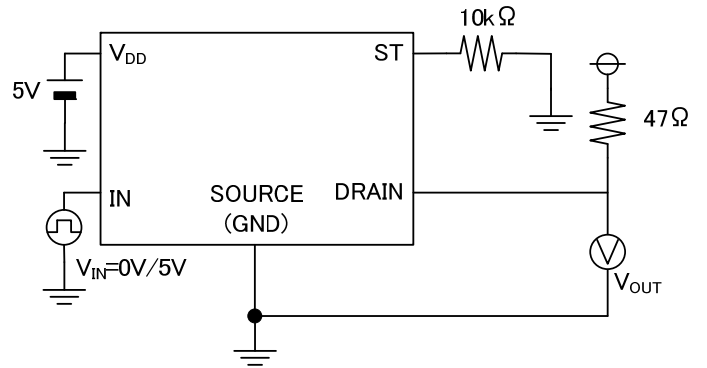

Figure 3. Switching Time Measuring Circuit Diagram

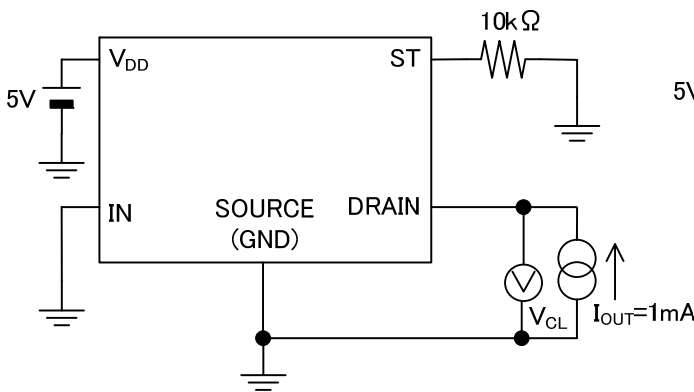

Figure 4. Output Clamp Voltage Measuring Circuit Diagram

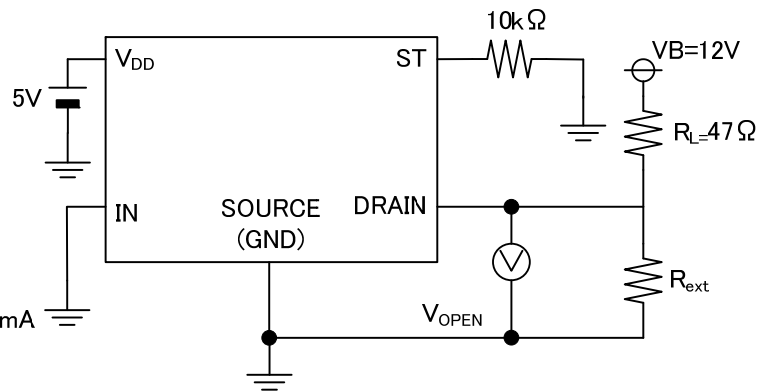

Figure 5. Open Detection Measuring Circuit Diagram

Diagnostic Output Truth Table

V _{IN}	T _j	OUTPUT		Mode	V _{ST}	Output state
		V _{OUT}	I _{OUT}			
H	T _j ≤ 175°C(Typ)	-	I _{OUT} < 1.5A(Typ)	Normal	H	ON
			I _{OUT} ≥ 1.5A(Typ)	Overcurrent detection	L	OFF
	T _j > 175°C(Typ)	-	-	Thermal shut down	L	OFF
L	-	H (3.0V or more)	-	Normal	H	OFF
		L (2.0V(Typ) or less)	-	Open load protection	L	OFF

Characteristic Data (Reference Data) ($V_{DD}=5V$, $I_N=5V$, $T_j=25^\circ C$ unless otherwise is specified)

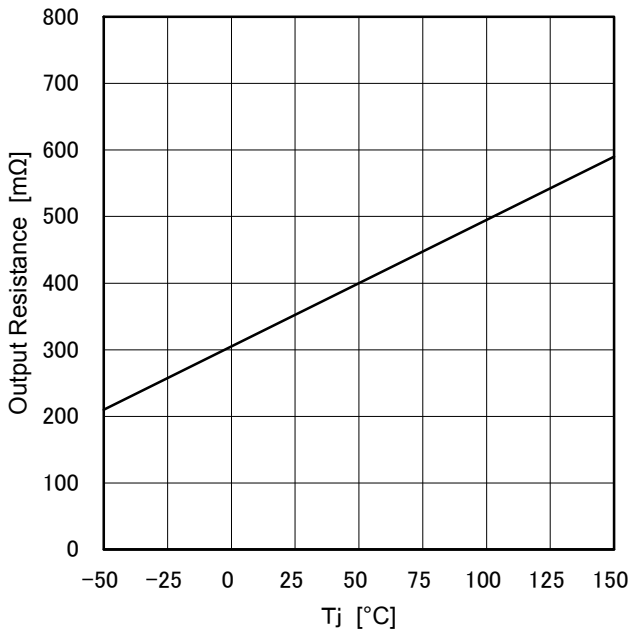

Figure 6. Output ON Resistance Characteristic [Temperature Characteristic]

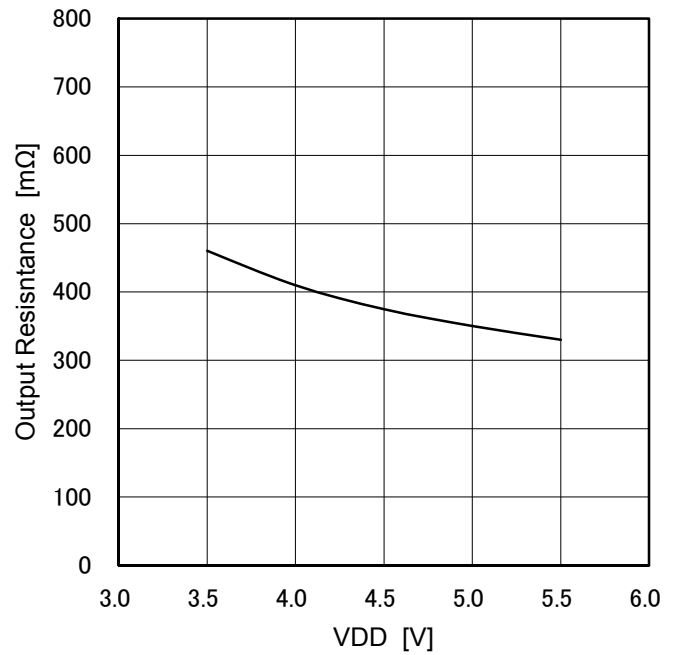

Figure 7. Output ON Resistance Characteristic [Source Voltage Characteristic]

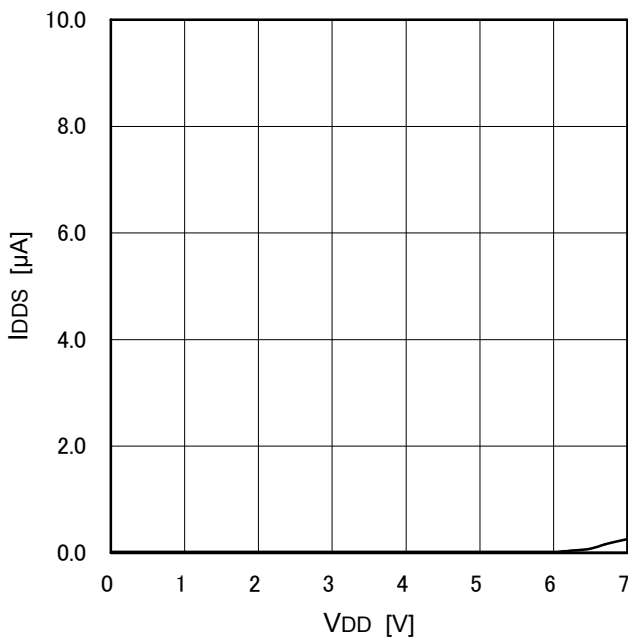

Figure 8. Standby Current Characteristic [Source Voltage Characteristic]

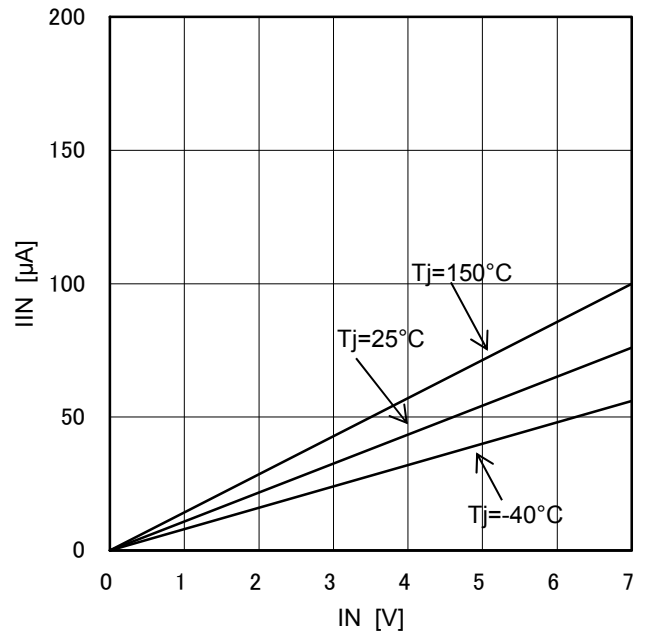

Figure 9. Input Current Characteristic [Input Voltage Characteristic]

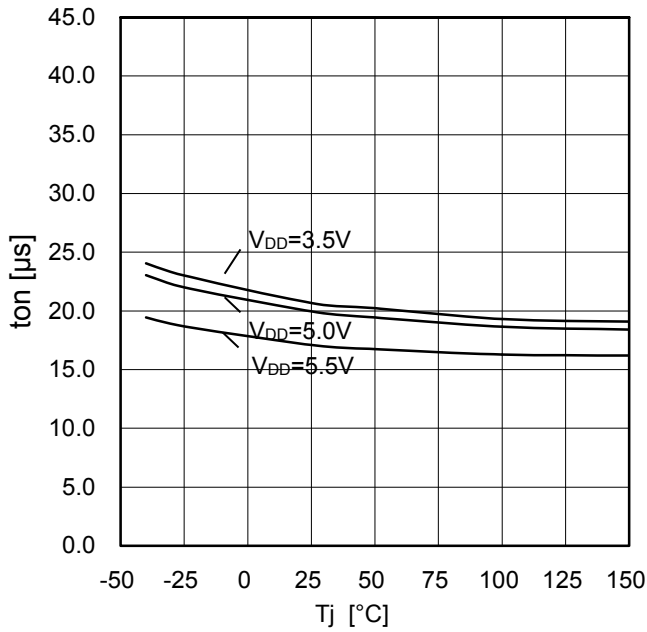

Figure 10. Switching Time (ton) [Temperature Characteristic]

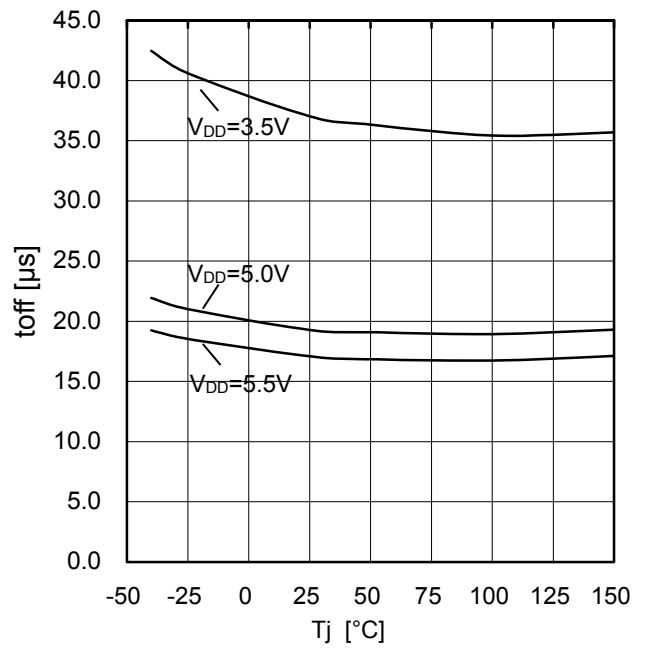

Figure 11. Switching Time (toff) [Temperature Characteristic]

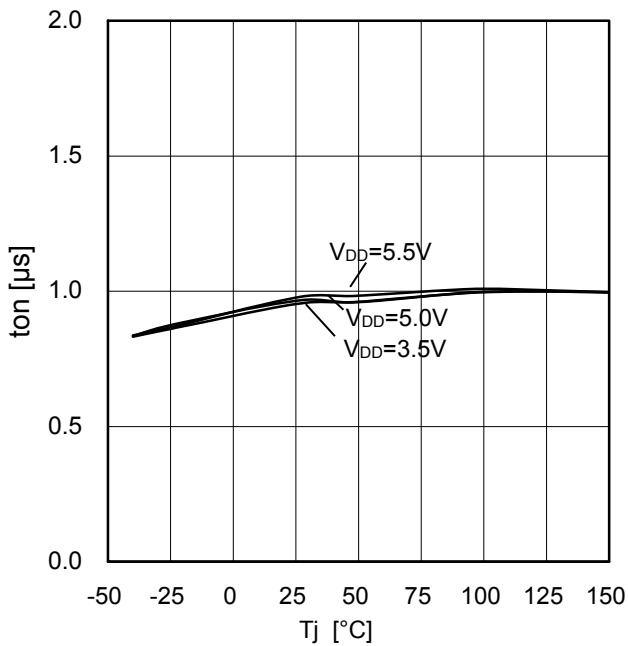

Figure 12. Slew Rate (at ON) [Temperature Characteristic]

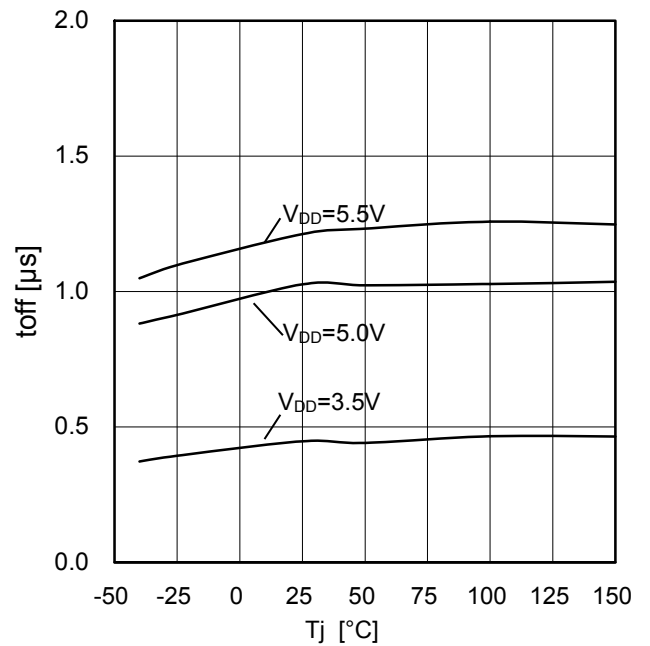

Figure 13. Slew Rate (at OFF) [Temperature Characteristic]

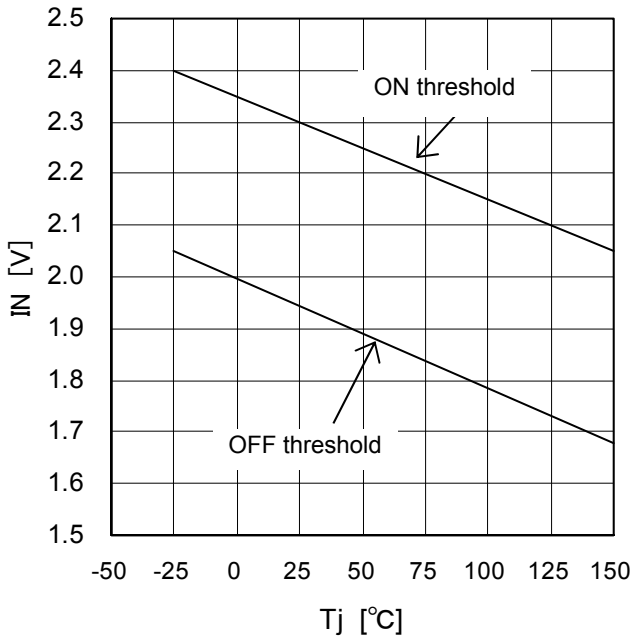

Figure 14. Input Voltage Threshold Characteristic [Temperature Characteristic]

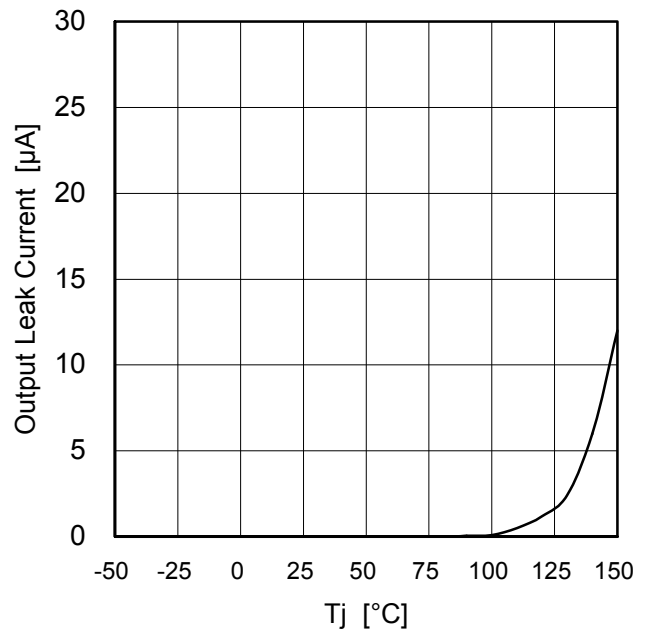

Figure 15. Output Leak Current [Temperature Characteristic] (VIN=0V)

Switching Time Measurement

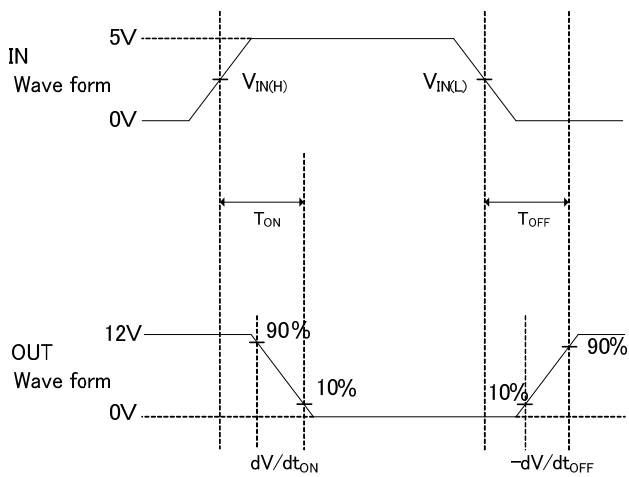

Figure 16. Switching Time

Timing Chart with Inductive Load

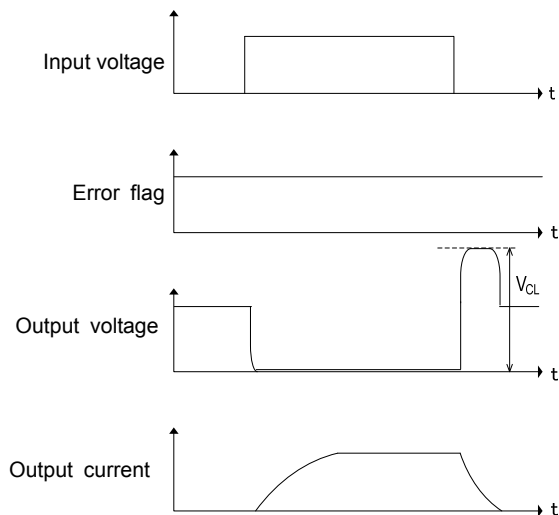

Figure 17. Timing Chart with Inductive Load

Protective Function Timing Charts

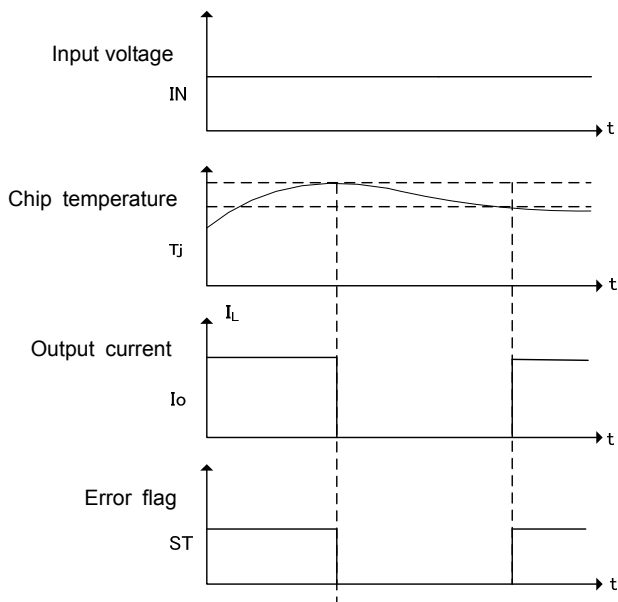

Figure 18. Overheat Protection Timing Chart

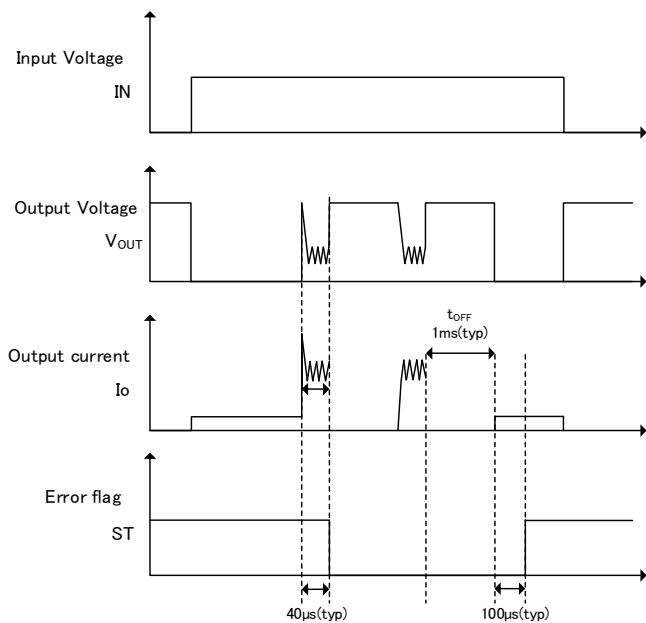

Figure 19. Overcurrent Protection Timing Chart

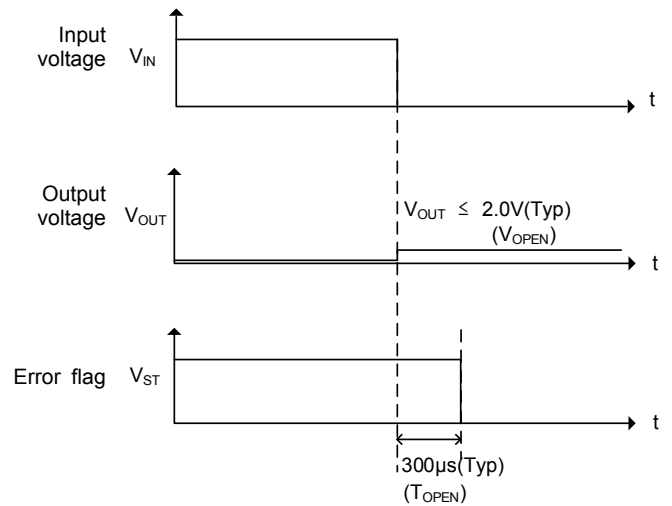

Figure 20. Open Detection Protection Timing Chart

I/O Equivalent Circuits

Pin	Symbol	I/O Equivalent Circuits
1	IN	
2	ST	
3,4	SOURCE (GND)	
5,6	DRAIN	
8	VDD	
Cooling Tab	TAB	

Ordering Information

B D 1 L B 5 0 0 E F J - CE2

PKG
EFJ: HTSOP-J8

C: High reliability
Packaging and forming specification
E2: Embossed tape and reel

B D 1 L B 5 0 0 F V M - CGTR

PKG
FVM: MSOP8

C: High reliability
G: Manufacturing code
Packaging and forming specification
TR: Embossed tape and reel

Physical Dimension Tape and Reel Information

HTSOP-J8

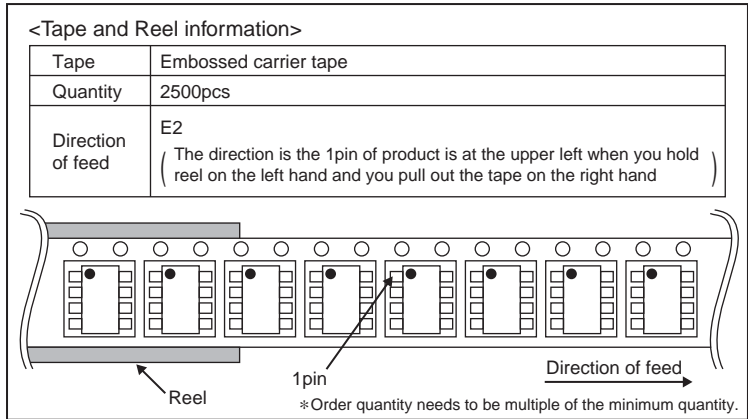
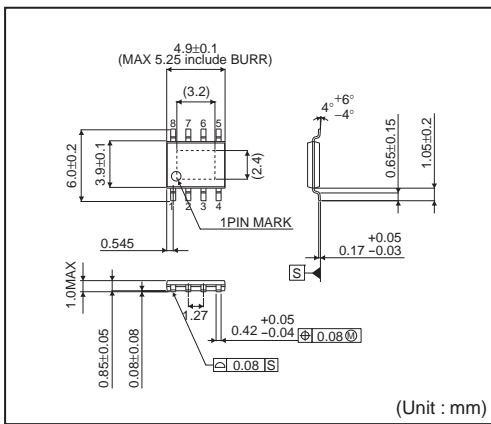

MSOP8

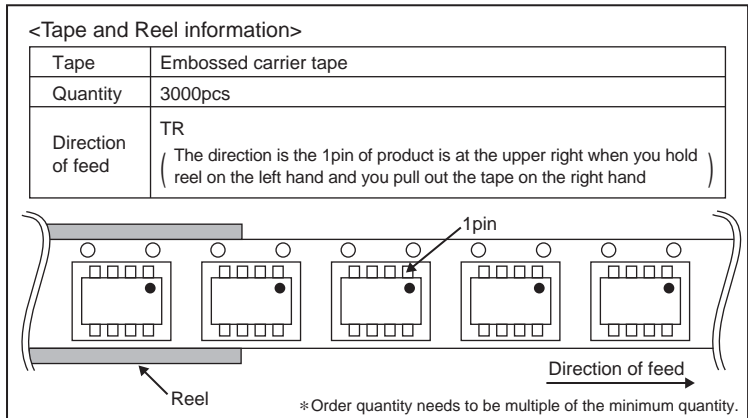
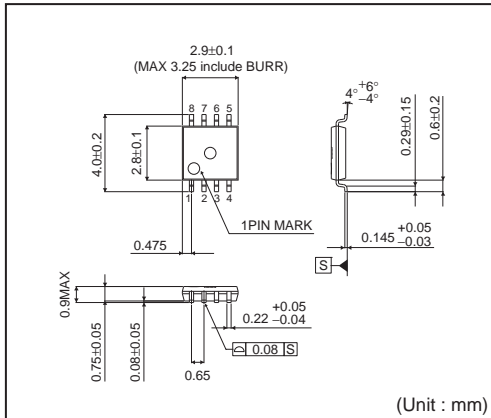

Marking Diagram

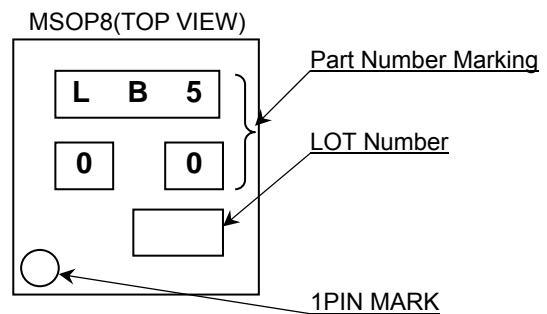
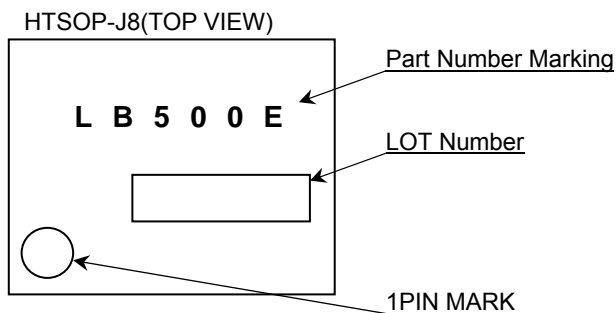

Operational Notes

- 1) Absolute Maximum Ratings
Operating the IC over the absolute maximum ratings may damage the IC. In addition, it is impossible to predict all destructive situations such as short-circuit modes or open circuit modes. Therefore, it is important to consider circuit protection measures, like adding a fuse, in case the IC is expected to be operated in a special mode exceeding the absolute maximum ratings.
- 2) Reverse connection of power supply
Connecting the power supply in reverse polarity can damage the IC. Take precautions against reverse polarity when connecting the power supply, such as mounting an external diode between the power supply and the IC's power supply terminals.
- 3) Power supply lines
Design the PCB layout pattern to provide low impedance ground and supply lines. Separate the ground and supply lines of the digital and analog blocks to prevent noise in the ground and supply lines of the digital block from affecting the analog block. Furthermore, connect a capacitor to ground at all power supply pins. Consider the effect of temperature and aging on the capacitance value when using electrolytic capacitors.
- 4) Source (GND) Voltage
The voltage of the Source (GND) pin must be the lowest voltage of all pins of the IC at all operating conditions. Ensure that no pins are at a voltage below the ground pin at any time, even during transient condition.
- 5) Thermal consideration
Use a thermal design that allows for a sufficient margin by taking into account the permissible power dissipation (Pd) in actual operating conditions. Consider Pc that does not exceed Pd in actual operating conditions ($P_c \geq P_d$).

Package Power dissipation : P_d (W) = $(T_{jmax} - T_a) / \theta_{ja}$
 Power dissipation : P_c (W) = $(V_{cc} - V_o) \times I_o + V_{cc} \times I_b$

T_{jmax} : Maximum junction temperature = 150°C, T_a : Peripheral temperature [°C],
 θ_{ja} : Thermal resistance of package-ambient [°C/W], P_d : Package Power dissipation [W],
 P_c : Power dissipation [W], V_{cc} : Input Voltage, V_o : Output Voltage, I_o : Load, I_b : Bias Current

- 6) Short between pins and mounting errors
Be careful when mounting the IC on printed circuit boards. The IC may be damaged if it is mounted in a wrong orientation or if pins are shorted together. Short circuit may be caused by conductive particles caught between the pins.
- 7) Thermal shutdown circuit (TSD)
The IC incorporates a built-in thermal shutdown circuit, which is designed to turn off the IC when the internal temperature of the IC reaches 175°C (25°C hysteresis). It is not designed to protect the IC from damage or guarantee its operation. Do not continue to operate the IC after this function is activated. Do not use the IC in conditions where this function will always be activated.
- 8) Over voltage protection (active clamp)
There is a built-in over voltage protection circuit (active clamp) to absorb the induced current when inductive load is off (Power MOS = off). During active clamp and when $I_N = 0V$, TSD will not function so keep IC temperature below 150°C.
- 9) Over current protection circuit (OCP)
The IC incorporates an over-current protection circuit that operates in accordance with the rated output capacity. This circuit protects the IC from damage when the load becomes shorted. It is also designed to limit the output current (without latching) in the event of more than 1.5A (typ) flow, such as from a large capacitor or other component connected to the output pin. This protection circuit is effective in preventing damage to the IC in cases of sudden and unexpected current surges. The IC should not be used in applications where the over current protection circuit will be activated continuously.
- 10) Testing on application boards
When testing the IC on an application board, connecting a capacitor directly to a low-impedance output pin may subject the IC to stress. Always discharge capacitors completely after each process or step. The IC's power supply should always be turned off completely before connecting or removing it from the test setup during the inspection process. To prevent damage from static discharge, ground the IC during assembly and use similar precautions during transport and storage.
- 11) Regarding input pins of the IC
This monolithic IC contains P+ isolation and P substrate layers between adjacent elements in order to keep them isolated. P-N junctions are formed at the intersection of the P layers with the N layers of other elements, creating a parasitic diode or transistor. For example (refer to figure below):

When $GND > Pin A$ and $GND > Pin B$, the P-N junction operates as a parasitic diode.
 When $GND > Pin B$, the P-N junction operates as a parasitic transistor.

Parasitic diodes inevitably occur in the structure of the IC. The operation of parasitic diodes can result in mutual interference among circuits, operational faults, or physical damage. Therefore, conditions that cause these diodes to operate, such as applying a voltage lower than the GND voltage to an input pin (and thus to the P substrate) should be avoided.

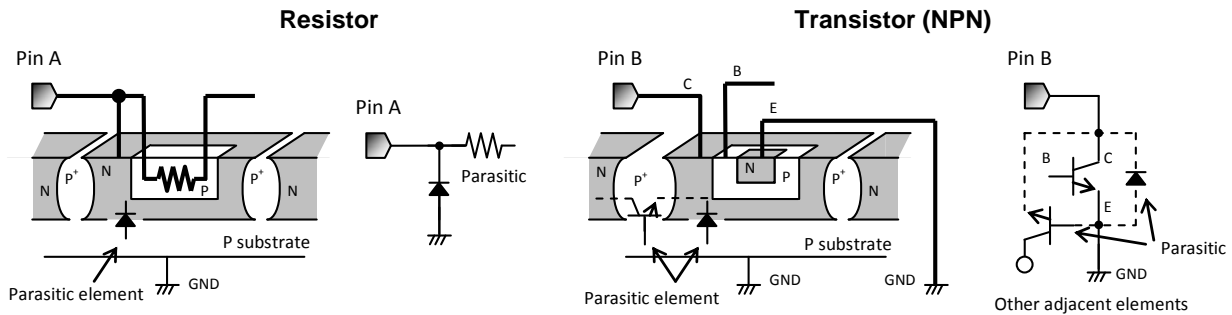

Example of monolithic IC structure

- 12) **GND wiring pattern**
 When using both small-signal and large-current GND traces, the two ground traces should be routed separately but connected to a single ground at the reference point of the application board to avoid fluctuations in the small-signal ground caused by large currents. Also ensure that the GND traces of external components do not cause variations on the GND voltage. The power supply and ground lines must be as short and thick as possible to reduce line impedance.
- 13) **Back electromotive force (BEMF)**
 There is a possibility that the BEMF is changed by using the operating condition, environment and the individual characteristics of motor. Please make sure there is no problem when operating the IC even though the BEMF is changed.
- 14) **Rush Current**
 When power is supplied to the IC, inrush current may flow instantaneously. It is possible that the charge current from the parasitic capacitance of the internal logic may be unstable. Therefore, give a special consideration with the power coupling capacitance, power wiring, width of GND wiring, and routing of connections.
- 15) **TAB**
 IC' sub is already connected to TAB, please short TAB to External GND.

Revision History

Date	Revision	Changes
01.Aug.2013	003	New release
06.Aug.2013	004	<ul style="list-style-type: none"> • P.11 Figure20 V_{OUT} timing chart is modified.
10.Jan.2014	005	<ul style="list-style-type: none"> • P4. Condition of Diagnostic output voltage “L level” is added. • P4. Item of Diagnostic output voltage “H level” is added.
1.Apr.2015	006	<ul style="list-style-type: none"> • P1. “AEC-Q100 qualified” is added in Features • P1. Note (1),(2) and (3) are added • P2. Pin No 7 N.C. is added in Pin Description • P2. “Cooling Tab”(Symbol; TAB) is added in Pin Description • P3. Note (6) is added • P4. Min of “ Diagnostic output voltage “H level” “ is changed to 4.88V • P9. ”ton” is changed to “toff” in Figure 11. 13. • P10. Figure 17 is changed • P15. FIN is changed to TAB in 15)
10.Nov.2015	007	<ul style="list-style-type: none"> • P3. “Absolute Maximum Ratings” Note (5) is changed • P3. “Heat Dissipation Characteristics” Note(3) is changed
26.May.2017	008	<ul style="list-style-type: none"> • P1. “Basic Application Circuit(Recommendation)” Comment of note (3) is added • P3. Active clamp energy (single pulse) limit value of T_J(0)=150°C is added in “Absolute Maximum Ratings”. • P13. Revised expression on the information of Ordering Information.

Notice

Precaution on using ROHM Products

1. If you intend to use our Products in devices requiring extremely high reliability (such as medical equipment ^(Note 1), aircraft/spacecraft, nuclear power controllers, etc.) and whose malfunction or failure may cause loss of human life, bodily injury or serious damage to property ("Specific Applications"), please consult with the ROHM sales representative in advance. Unless otherwise agreed in writing by ROHM in advance, ROHM shall not be in any way responsible or liable for any damages, expenses or losses incurred by you or third parties arising from the use of any ROHM's Products for Specific Applications.

(Note1) Medical Equipment Classification of the Specific Applications

JAPAN	USA	EU	CHINA
CLASS III	CLASS III	CLASS II b	CLASS III
CLASS IV		CLASS III	

2. ROHM designs and manufactures its Products subject to strict quality control system. However, semiconductor products can fail or malfunction at a certain rate. Please be sure to implement, at your own responsibilities, adequate safety measures including but not limited to fail-safe design against the physical injury, damage to any property, which a failure or malfunction of our Products may cause. The following are examples of safety measures:
 - [a] Installation of protection circuits or other protective devices to improve system safety
 - [b] Installation of redundant circuits to reduce the impact of single or multiple circuit failure
3. Our Products are not designed under any special or extraordinary environments or conditions, as exemplified below. Accordingly, ROHM shall not be in any way responsible or liable for any damages, expenses or losses arising from the use of any ROHM's Products under any special or extraordinary environments or conditions. If you intend to use our Products under any special or extraordinary environments or conditions (as exemplified below), your independent verification and confirmation of product performance, reliability, etc. prior to use, must be necessary:
 - [a] Use of our Products in any types of liquid, including water, oils, chemicals, and organic solvents
 - [b] Use of our Products outdoors or in places where the Products are exposed to direct sunlight or dust
 - [c] Use of our Products in places where the Products are exposed to sea wind or corrosive gases, including Cl₂, H₂S, NH₃, SO₂, and NO₂
 - [d] Use of our Products in places where the Products are exposed to static electricity or electromagnetic waves
 - [e] Use of our Products in proximity to heat-producing components, plastic cords, or other flammable items
 - [f] Sealing or coating our Products with resin or other coating materials
 - [g] Use of our Products without cleaning residue of flux (even if you use no-clean type fluxes, cleaning residue of flux is recommended); or Washing our Products by using water or water-soluble cleaning agents for cleaning residue after soldering
 - [h] Use of the Products in places subject to dew condensation
4. The Products are not subject to radiation-proof design.
5. Please verify and confirm characteristics of the final or mounted products in using the Products.
6. In particular, if a transient load (a large amount of load applied in a short period of time, such as pulse. is applied, confirmation of performance characteristics after on-board mounting is strongly recommended. Avoid applying power exceeding normal rated power; exceeding the power rating under steady-state loading condition may negatively affect product performance and reliability.
7. De-rate Power Dissipation depending on ambient temperature. When used in sealed area, confirm that it is the use in the range that does not exceed the maximum junction temperature.
8. Confirm that operation temperature is within the specified range described in the product specification.
9. ROHM shall not be in any way responsible or liable for failure induced under deviant condition from what is defined in this document.

Precaution for Mounting / Circuit board design

1. When a highly active halogenous (chlorine, bromine, etc.) flux is used, the residue of flux may negatively affect product performance and reliability.
2. In principle, the reflow soldering method must be used on a surface-mount products, the flow soldering method must be used on a through hole mount products. If the flow soldering method is preferred on a surface-mount products, please consult with the ROHM representative in advance.

For details, please refer to ROHM Mounting specification

Precautions Regarding Application Examples and External Circuits

1. If change is made to the constant of an external circuit, please allow a sufficient margin considering variations of the characteristics of the Products and external components, including transient characteristics, as well as static characteristics.
2. You agree that application notes, reference designs, and associated data and information contained in this document are presented only as guidance for Products use. Therefore, in case you use such information, you are solely responsible for it and you must exercise your own independent verification and judgment in the use of such information contained in this document. ROHM shall not be in any way responsible or liable for any damages, expenses or losses incurred by you or third parties arising from the use of such information.

Precaution for Electrostatic

This Product is electrostatic sensitive product, which may be damaged due to electrostatic discharge. Please take proper caution in your manufacturing process and storage so that voltage exceeding the Products maximum rating will not be applied to Products. Please take special care under dry condition (e.g. Grounding of human body / equipment / solder iron, isolation from charged objects, setting of Ionizer, friction prevention and temperature / humidity control).

Precaution for Storage / Transportation

1. Product performance and soldered connections may deteriorate if the Products are stored in the places where:
 - [a] the Products are exposed to sea winds or corrosive gases, including Cl₂, H₂S, NH₃, SO₂, and NO₂
 - [b] the temperature or humidity exceeds those recommended by ROHM
 - [c] the Products are exposed to direct sunshine or condensation
 - [d] the Products are exposed to high Electrostatic
2. Even under ROHM recommended storage condition, solderability of products out of recommended storage time period may be degraded. It is strongly recommended to confirm solderability before using Products of which storage time is exceeding the recommended storage time period.
3. Store / transport cartons in the correct direction, which is indicated on a carton with a symbol. Otherwise bent leads may occur due to excessive stress applied when dropping of a carton.
4. Use Products within the specified time after opening a humidity barrier bag. Baking is required before using Products of which storage time is exceeding the recommended storage time period.

Precaution for Product Label

A two-dimensional barcode printed on ROHM Products label is for ROHM's internal use only.

Precaution for Disposition

When disposing Products please dispose them properly using an authorized industry waste company.

Precaution for Foreign Exchange and Foreign Trade act

Since concerned goods might be fallen under listed items of export control prescribed by Foreign exchange and Foreign trade act, please consult with ROHM in case of export.

Precaution Regarding Intellectual Property Rights

1. All information and data including but not limited to application example contained in this document is for reference only. ROHM does not warrant that foregoing information or data will not infringe any intellectual property rights or any other rights of any third party regarding such information or data.
2. ROHM shall not have any obligations where the claims, actions or demands arising from the combination of the Products with other articles such as components, circuits, systems or external equipment (including software).
3. No license, expressly or implied, is granted hereby under any intellectual property rights or other rights of ROHM or any third parties with respect to the Products or the information contained in this document. Provided, however, that ROHM will not assert its intellectual property rights or other rights against you or your customers to the extent necessary to manufacture or sell products containing the Products, subject to the terms and conditions herein.

Other Precaution

1. This document may not be reprinted or reproduced, in whole or in part, without prior written consent of ROHM.
2. The Products may not be disassembled, converted, modified, reproduced or otherwise changed without prior written consent of ROHM.
3. In no event shall you use in any way whatsoever the Products and the related technical information contained in the Products or this document for any military purposes, including but not limited to, the development of mass-destruction weapons.
4. The proper names of companies or products described in this document are trademarks or registered trademarks of ROHM, its affiliated companies or third parties.

General Precaution

1. Before you use our Products, you are requested to carefully read this document and fully understand its contents. ROHM shall not be in any way responsible or liable for failure, malfunction or accident arising from the use of any ROHM's Products against warning, caution or note contained in this document.
2. All information contained in this document is current as of the issuing date and subject to change without any prior notice. Before purchasing or using ROHM's Products, please confirm the latest information with a ROHM sales representative.
3. The information contained in this document is provided on an "as is" basis and ROHM does not warrant that all information contained in this document is accurate and/or error-free. ROHM shall not be in any way responsible or liable for any damages, expenses or losses incurred by you or third parties resulting from inaccuracy or errors of or concerning such information.

X-ON Electronics

Largest Supplier of Electrical and Electronic Components

Click to view similar products for [Power Switch ICs - Power Distribution category](#):

Click to view products by [ROHM manufacturer](#):

Other Similar products are found below :

[TCK111G,LF\(S\)](#) [FPF1018](#) [DS1222](#) [TCK2065G,LF](#) [SZNCP3712ASNT3G](#) [MIC2033-05BYMT-T5](#) [MIC2033-12AYMT-T5](#) [MIC2033-05BYM6-T5](#) [SLG5NT1437VTR](#) [SZNCP3712ASNT1G](#) [NCV330MUTBG](#) [DML1008LDS-7](#) [KTS1670EDA-TR](#) [KTS1640QGDV-TR](#) [KTS1641QGDV-TR](#) [NCV459MNWTBG](#) [FPF2260ATMX](#) [U6513A](#) [MIC2012YM-TR](#) [NCP45780IMN24RTWG](#) [MAX14919ATP+](#) [MC33882PEP](#) [TPS2104DBVR](#) [MIC2098-1YMT-TR](#) [MIC94062YMT TR](#) [MP6231DN-LF](#) [MIC2075-2YM](#) [MIC94068YML-TR](#) [SIP32461DB-T2-GE1](#) [NCP335FCT2G](#) [TCK105G,LF\(S\)](#) [AP2191DWG-7](#) [AP2151DSG-13](#) [MIC94094YC6-TR](#) [MIC94064YC6-TR](#) [MIC2505-1YM](#) [MIC94305YMT-TR](#) [MIC94085YFT-TR](#) [MIC94081YFT-TR](#) [MIC94042YFL-TR](#) [MIC94041YFL-TR](#) [MIC2005-1.2YM6-TR](#) [TPS2032QDRQ1](#) [SIP32510DT-T1-GE3](#) [NCP333FCT2G](#) [BTS3050TFATMA1](#) [NCP331SNT1G](#) [TPS2092DR](#) [TPS2063DR](#) [TPS2042P](#)