

Controller ICs for High Side NMOSFET

BD2270HFV

General Description

BD2270HFV is a gate driver for high side N-Channel MOSFET that comes with a discharge circuit for the output capacitive load. An internal charge pump enables the IC to drive the gate of an external high side NMOSFET without using any external parts. The power up sequence is controlled by a comparator with hysteresis function. The space saving HVSO5 package is used.

Key Specifications

■ Input Voltage Range:	2.7V to 5.5V
■ GATE Rise Time ($C_{GATE} = 500\text{pF}$):	130 μs (Typ)
■ GATE Output Voltage ($V_{CC} = 5\text{V}$):	13.5V (Typ)
■ Operating Current:	50 μA (Typ)
■ Standby Current:	5 μA (Typ)
■ Operating Temperature Range:	-25°C to +85°C

Package

W(Typ) D(Typ) H (Max)

Features

- Built-in Charge Pump Circuit Drives the Gate of the External N-Channel Power MOSFET
- Built-in Discharge Circuit for Output Charge
- Soft Start Circuit
- Built-in Comparator with Hysteresis Function at Control Block Input
- Possible to drive N-channel power MOSFET

Applications

PCs
PC Peripheral Devices
Digital Consumer Electronics

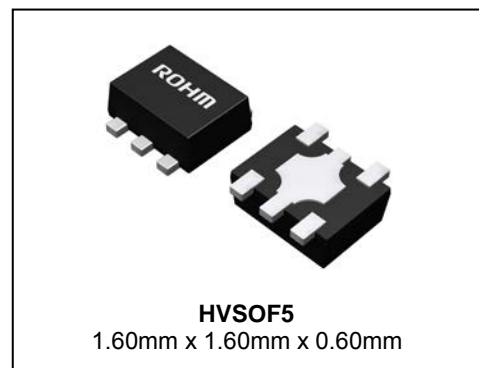

Typical Application Circuit

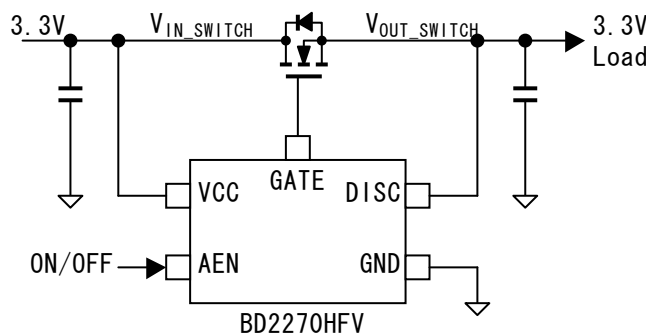

Lineup

GATE Output Voltage ($V_{CC} = 5\text{V}$)			Package		Orderable Part Number
Min	Typ	Max			
10V	13.5V	15V	HVSO5	Reel of 3000	BD2270HFV-TR BD2270HFV-GTR

Block Diagram

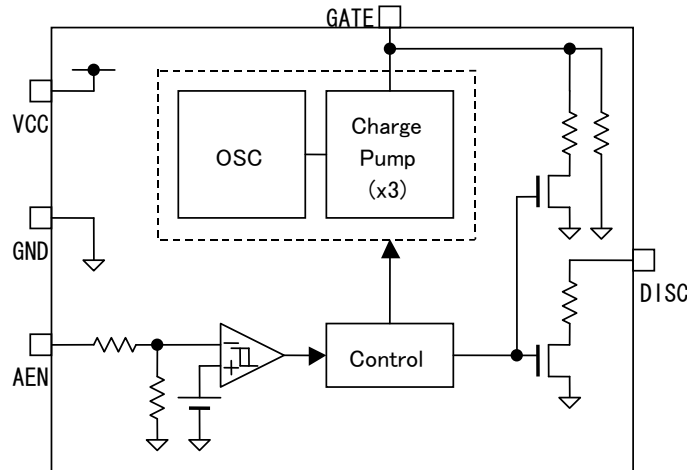

Pin Configuration

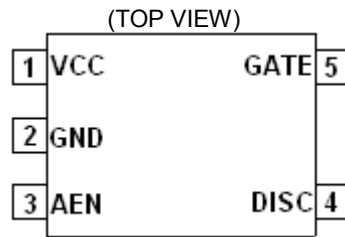

Pin Description

Pin No.	Pin Name	I / O	Function
1	VCC	-	Power input terminal
2	GND	-	Ground terminal
3	AEN	I	Control input terminal Turn on the external N-Channel MOSFET with a high level input. High level input > 2.0V, low level input < 0.8V
4	DISC	O	Switch output discharge terminal
5	GATE	O	Gate drive output terminal Connect to the gate of the external N-Channel MOSFET

Absolute Maximum Ratings

Parameter	Symbol	Rating	Unit
Supply Voltage	V _{CC}	-0.3 to +6.0	V
AEN Voltage	V _{AEN}	-0.3 to +6.0	V
DISC Voltage	V _{DISC}	-0.3 to +6.0	V
GATE Voltage	V _{GATE}	-0.3 to +15.0	V
Storage Temperature Range	T _{stg}	-55 to +150	°C
Power Dissipation	P _d	0.66 ^(Note 1)	W

(Note 1) Derate by 5.35mW/°C when operating above Ta=25°C (Mounted on a 70mm x 70mm x 1.6mm board).

Caution: Operating the IC over the absolute maximum ratings may damage the IC. The damage can either be a short circuit between pins or an open circuit between pins and the internal circuitry. Therefore, it is important to consider circuit protection measures, such as adding a fuse, in case the IC is operated over the absolute maximum ratings.

Recommended Operating Conditions

Parameter	Symbol	Rating			Unit
		Min	Typ	Max	
Operating Voltage Range	V _{CC}	2.7	-	5.5	V
Operating Temperature Range	Topr	-25	-	+85	°C

Electrical Characteristics (V_{CC}= 3.0V, Ta= 25°C unless otherwise specified)

Parameter	Symbol	Limit			Unit	Conditions
		Min	Typ	Max		
Operating Current	I _{CC}	-	50	75	µA	V _{AEN} = 2.5V
Standby Current	I _{STB}	-	5	10	µA	V _{AEN} = 0V
AEN Input Voltage	V _{AENH}	1.55	2	2.45	V	High Level Input
	V _{AENL}	1.35	1.9	2.35	V	Low Level Input
AEN Input Current	I _{AEN}	-	3	5	µA	V _{AEN} = 3V
GATE Output Voltage	V _{GATE}	10	13.5	15	V	V _{CC} = 5V
		6.6	9.5	9.9	V	V _{CC} = 3.3V
		6	8.5	9	V	V _{CC} = 3V
GATE Rise Time	t _{ON}	-	130	750	µs	C _{GATE} = 500pF V _{CC} = 3V V _{GATE} > 4V
GATE Fall Time	t _{OFF}	-	18	60	µs	C _{GATE} = 500pF V _{CC} = 3V V _{GATE} < 0.5V
DISC Discharge Resistance	R _{DISC}	-	200	300	Ω	V _{AEN} = 0V

Measurement Circuit

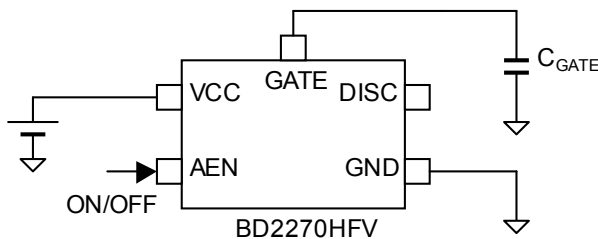

Timing Diagram

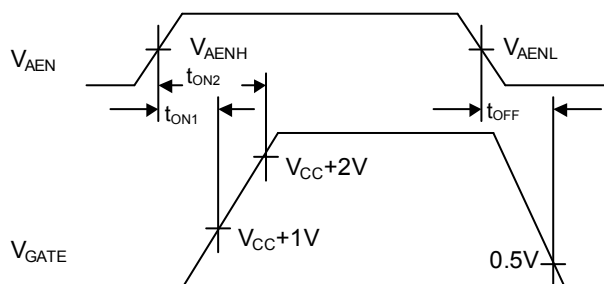

Typical Performance Curves

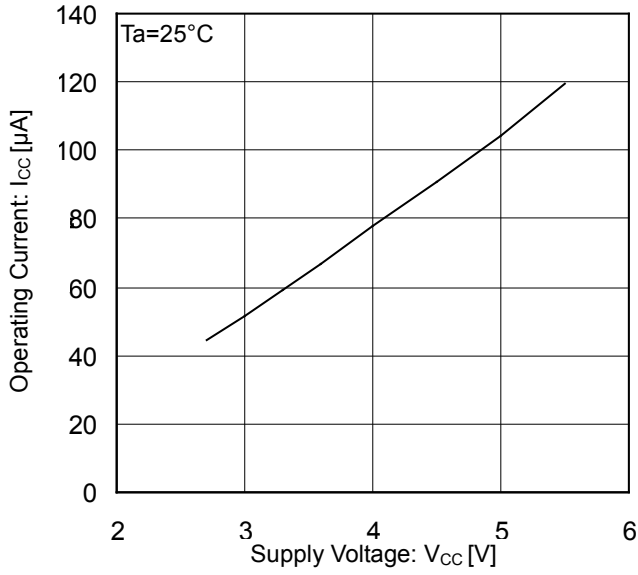

Figure 1. Operating Current vs Supply Voltage (AEN Enable)

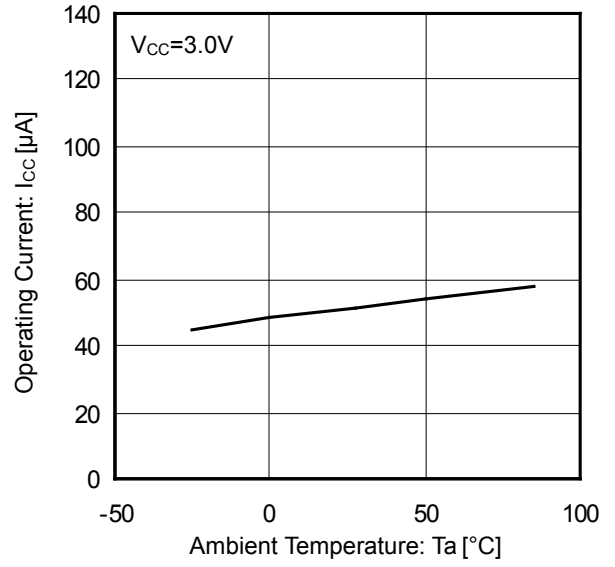

Figure 2. Operating Current vs Ambient Temperature (AEN Enable)

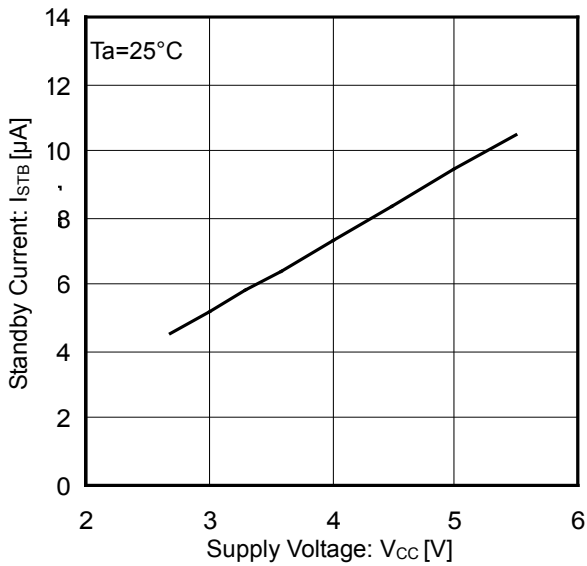

Figure 3. Standby Current vs Supply Voltage (AEN Disable)

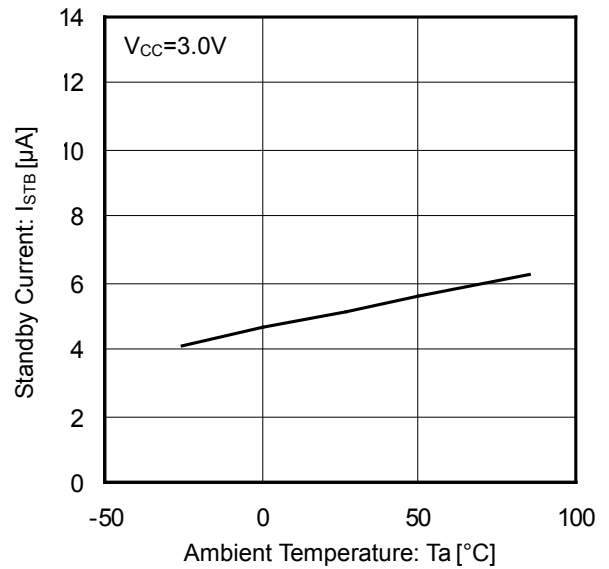

Figure 4. Standby Current vs Ambient Temperature (AEN Disable)

Typical Performance Curves - continued

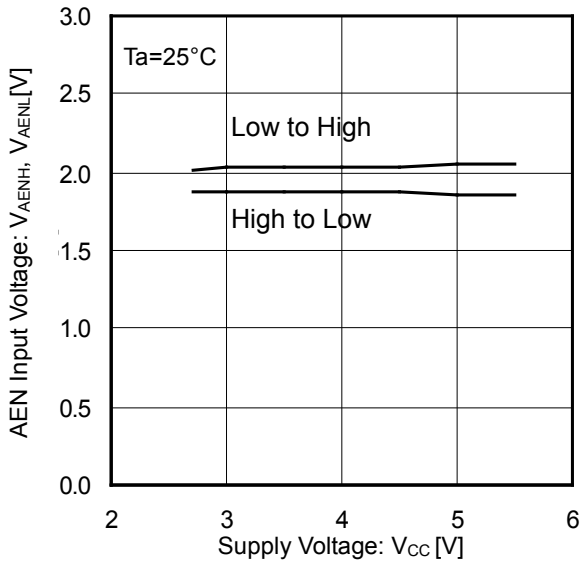

Figure 5. AEN Input Voltage vs Supply Voltage

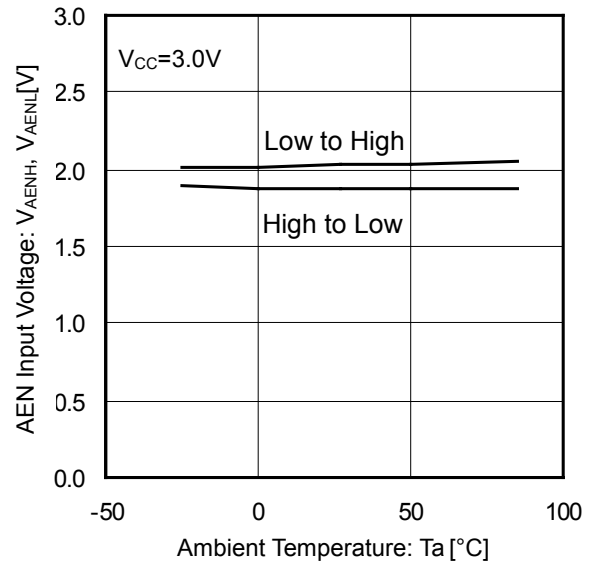

Figure 6. AEN Input Voltage vs Ambient Temperature

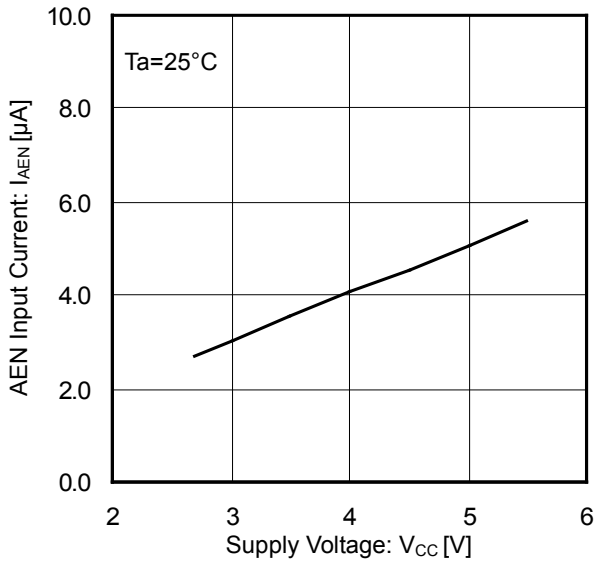

Figure 7. AEN Input Current vs Supply Voltage

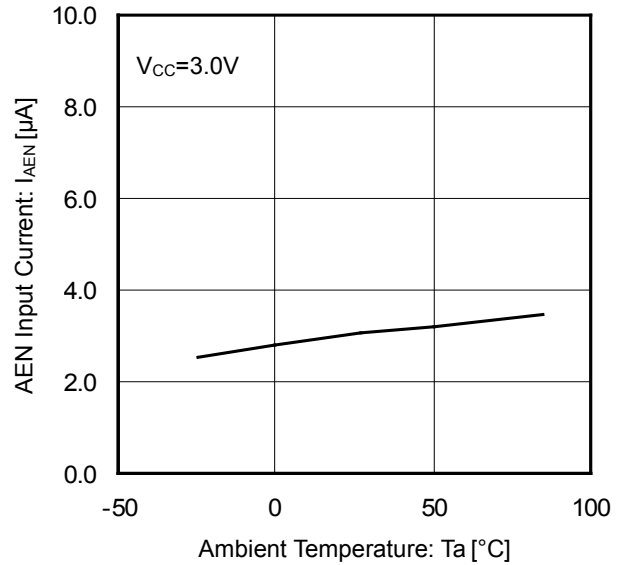

Figure 8. AEN Input Current vs Ambient Temperature

Typical Performance Curves - continued

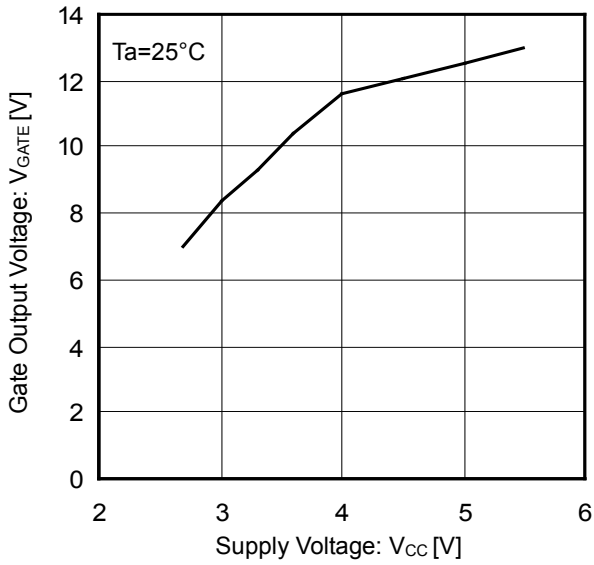

Figure 9. GATE Output Voltage vs Supply Voltage

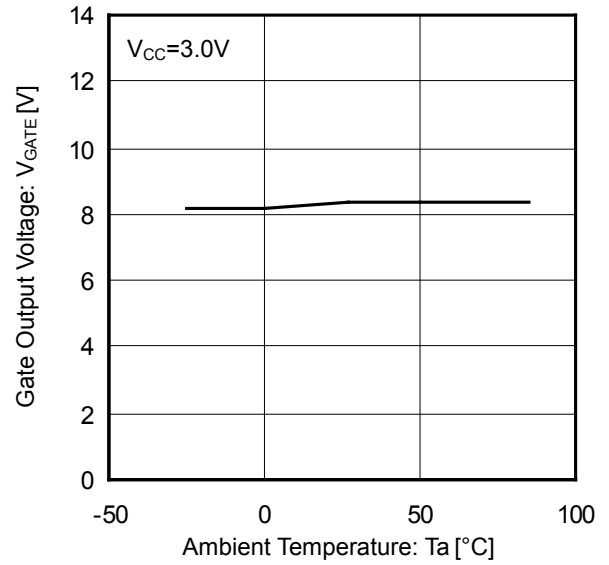

Figure 10. GATE Output Voltage vs Ambient Temperature

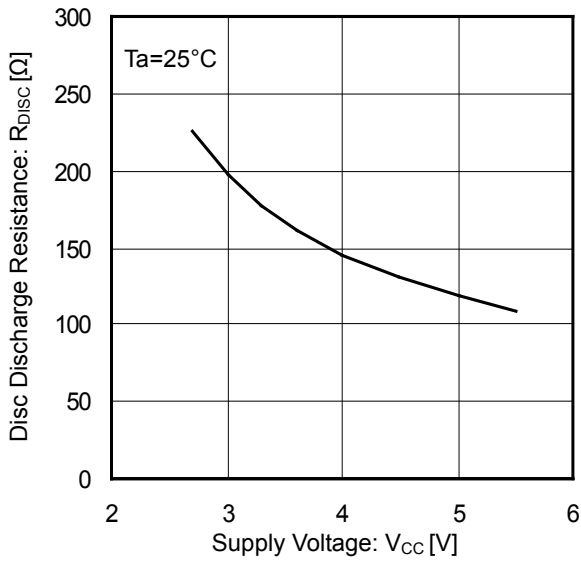

Figure 11. DISC Discharge Resistance vs Supply Voltage

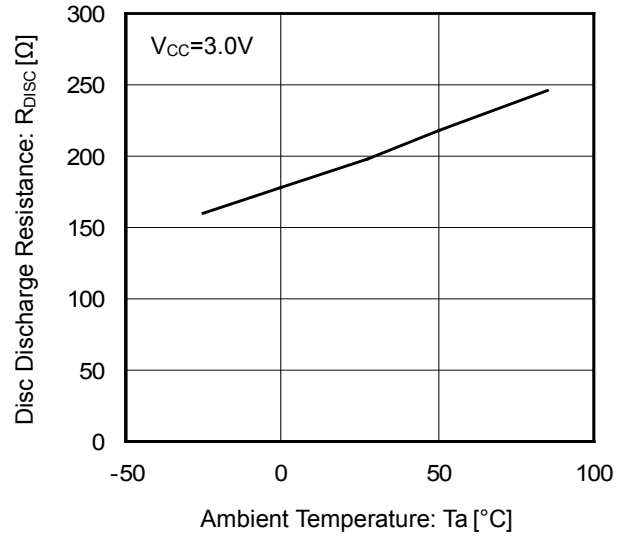

Figure 12. DISC Discharge Resistance vs Ambient Temperature

Typical Performance Curves - continued

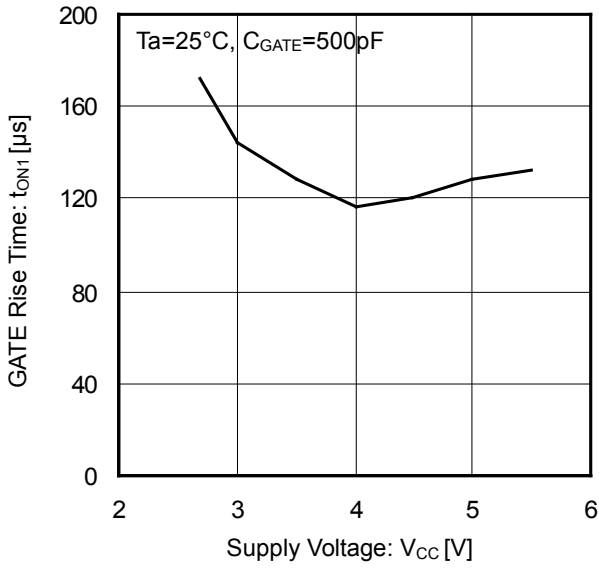

Figure 13. GATE Rise Time 1 vs Supply Voltage

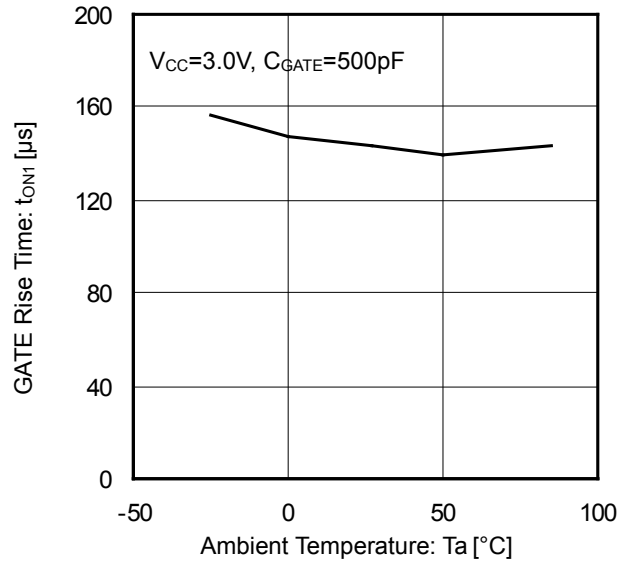

Figure 14. GATE Rise Time 1 vs Ambient Temperature

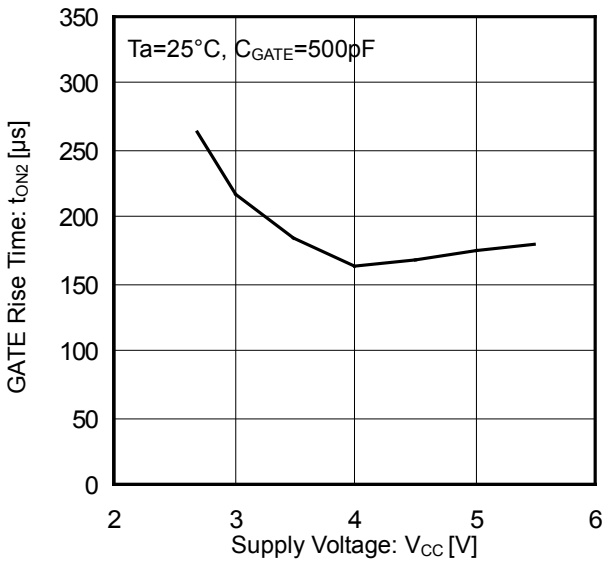

Figure 15. GATE Rise Time 2 vs Supply Voltage

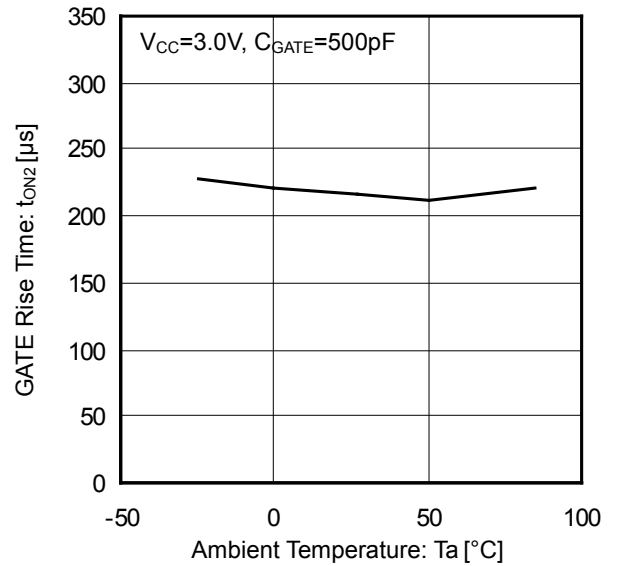

Figure 16. GATE Rise Time 2 vs Ambient Temperature

Typical Performance Curves - continued

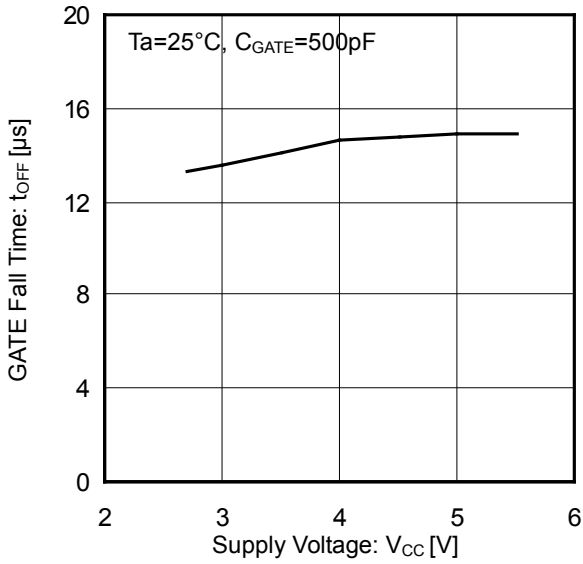

Figure 17. GATE Fall Time vs Supply Voltage

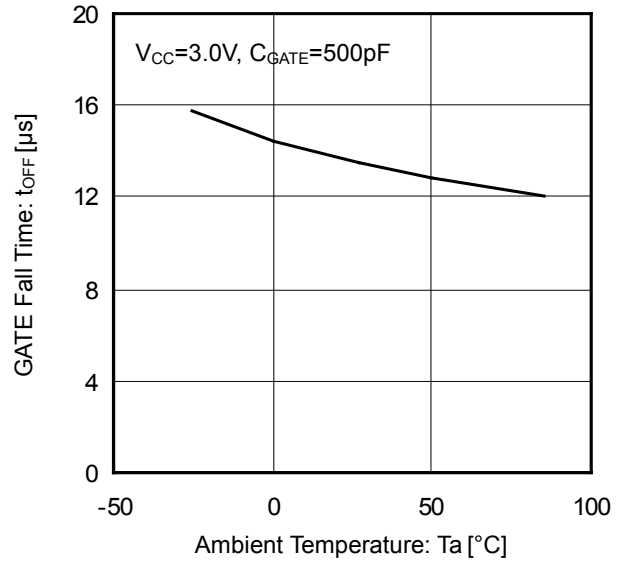

Figure 18. GATE Fall Time vs Ambient Temperature

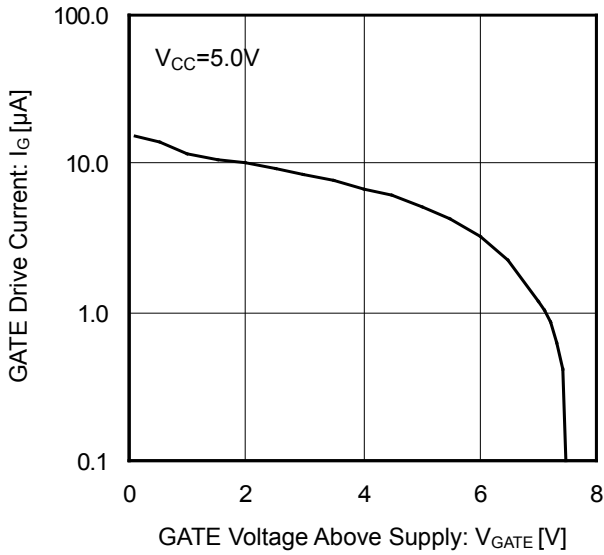

Figure 19. GATE Drive Current vs GATE Voltage Above Supply ($V_{CC} = 5V$)

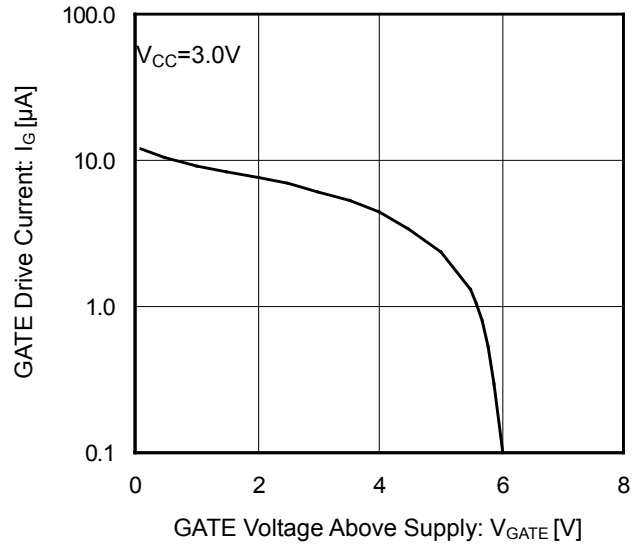

Figure 20. GATE Drive Current vs GATE Voltage Above Supply ($V_{CC} = 3V$)

Typical Wave Forms

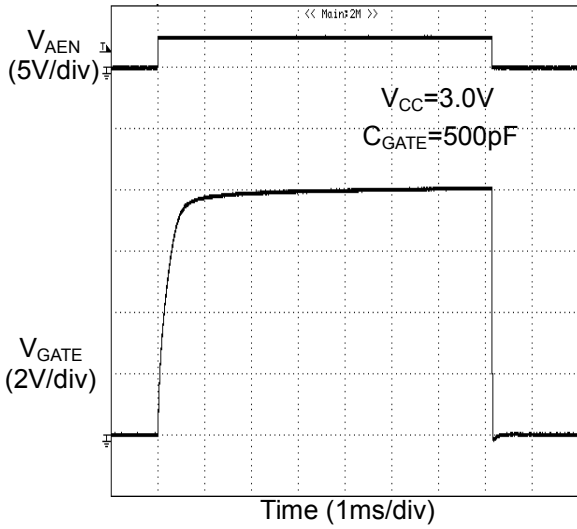

Figure 21. GATE Rise / Fall Characteristics

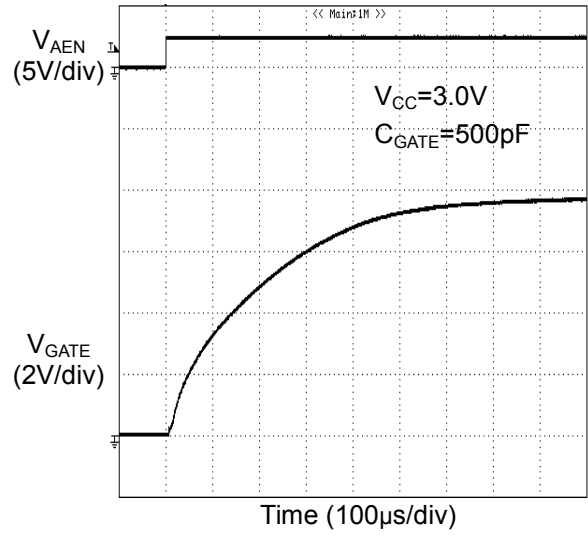

Figure 22. GATE Rise Characteristics

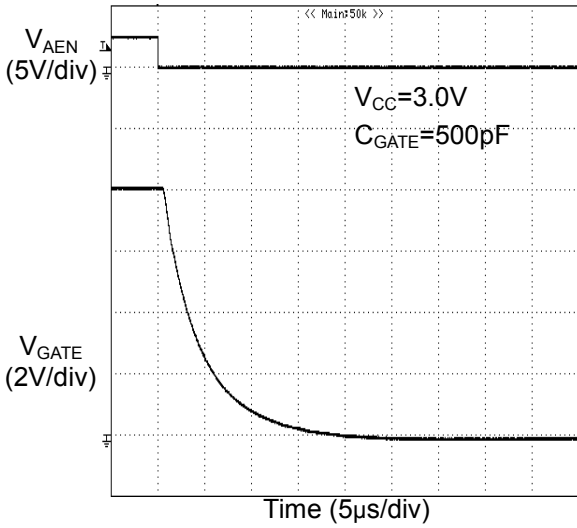

Figure 23. GATE Fall Characteristics

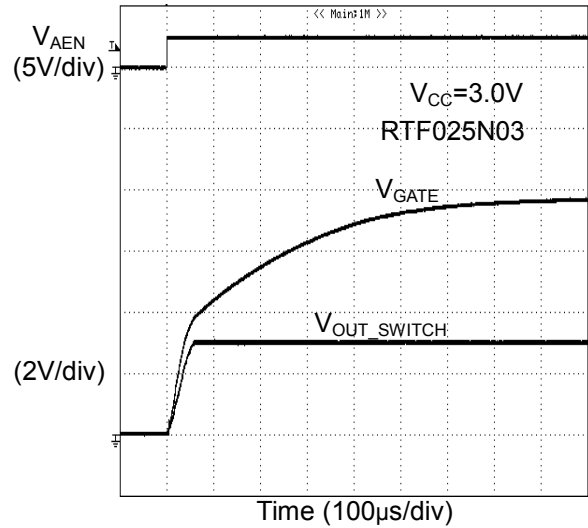

Figure 24. GATE Switch Rise Characteristics

Typical Wave Forms - continued

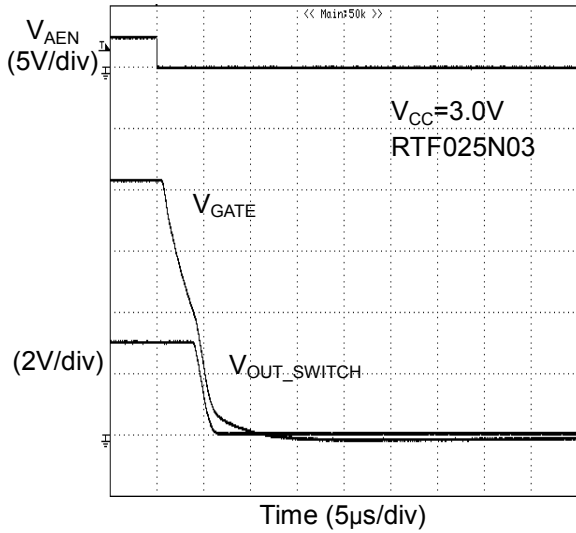

Figure 25. GATE Switch Fall Characteristics

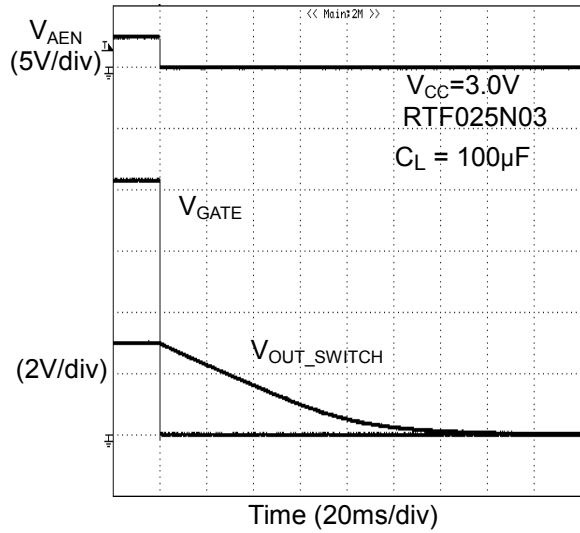

Figure 26. GATE Switch Fall Characteristics

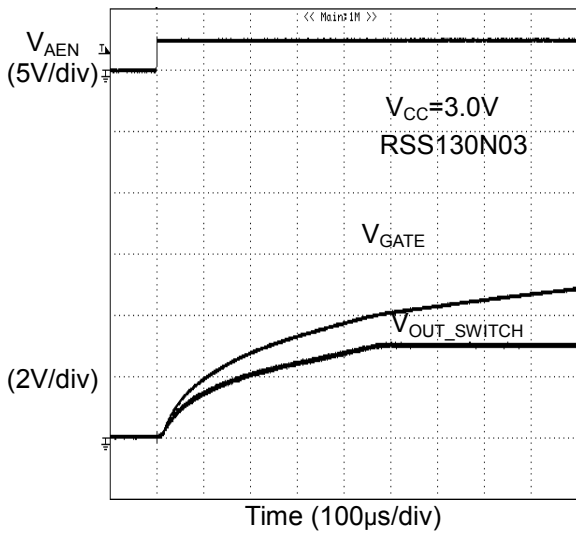

Figure 27. GATE Switch Rise Characteristics

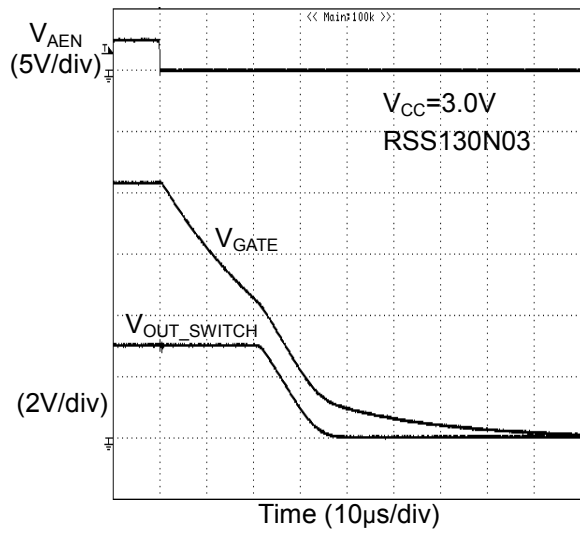

Figure 28. GATE Switch Fall Characteristics

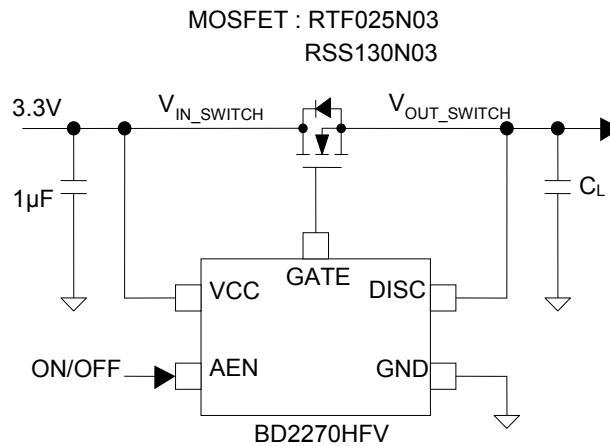

Figure 29. Switch Rise / Fall Characteristics Measurement Circuit Diagram

Application Circuit

1. Configuration of 3.3V Load Switch

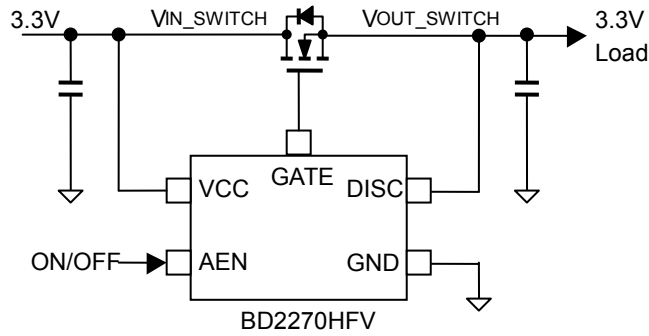

Figure 30. Configuration of 3.3V Load Switch

2. Configuration of 5V Load Switch

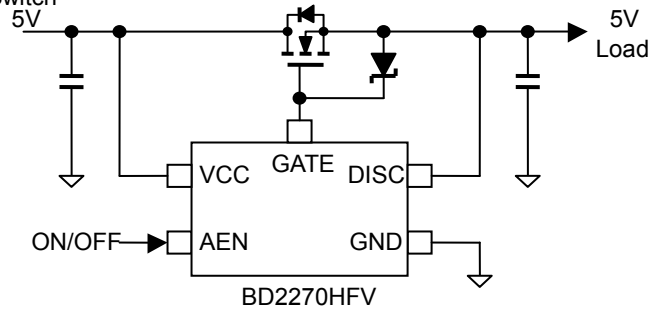

Figure 31. Configuration of 5V Load Switch

A 5V load switch can be configured like the 3.3V load switch. However, if the external N-Channel MOSFET has low VGSS, clamp it with a Zener diode or a similar component.

3. Configuration of Low-Voltage Load Switch

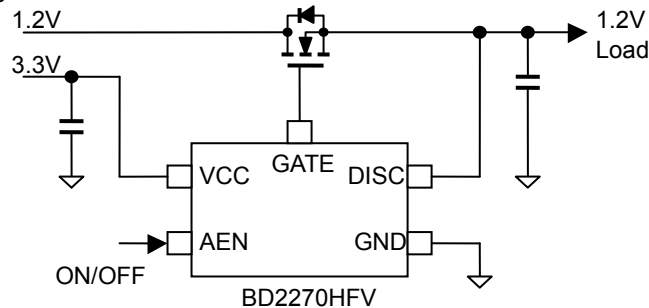

Figure 32. Configuration of Low-Voltage Load Switch

Providing BD2270HFV a separate drive power supply enables configuration of a low-voltage load switch.

4. Soft Start Configuration

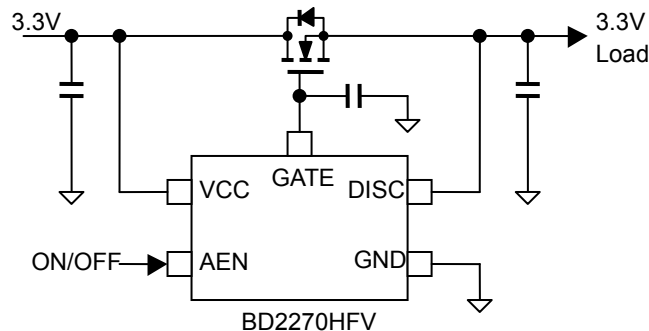

Figure 33. Soft Start Configuration

Connecting an external capacitor to the GATE terminal of BD2270HFV makes it possible to lengthen the rise time of the N-Channel MOSFET, thus achieving reduction of the inrush current to the large-capacity load capacitor.

Application Information

The system connection diagram shown here does not guarantee the operation of the application circuit.

When the recommended external circuit components are changed, be sure to consider adequate margins by taking into account external parts and/or IC's dispersion including not only static characteristics, but also transient characteristics.

1. Functional Description

The BD2270HFV is a gate driver IC for N-Channel MOSFETs used as high side load switches. This IC incorporates the following functions.

(1) GATE Drive

The gate drive voltage of the external N-Channel MOSFET is generated by an internal charge pump in the BD2270HFV. The charge pump generates a voltage three times as high as the power supply voltage at the GATE terminal. In addition, since this IC has an internal capacitor for the charge pump, it needs no external parts.

The charge pump operates when the AEN is set to High. When the AEN is set to Low, the GATE terminal voltage is fixed to the GND level.

(2) Output Discharge Circuit

The output discharge circuit is enabled when the AEN is set to Low. When the discharge circuit is activated, the 200Ω (Typ) MOSFET switch located between the DISC terminal and the GND terminal turns ON. Connecting the DISC terminal and the source side (load side) of the N-Channel MOSFET makes it possible to immediately discharge capacitive load.

(3) Soft Start Function

When the AEN terminal input voltage reaches the High level, the internal charge pump charges the gate of the N-Channel MOSFET. The Turn ON time of the N-Channel MOSFET is determined by the GATE capacity. In addition, connecting a capacitor to the GATE terminal makes it possible to lengthen the rise of Turn ON time of the N-Channel MOSFET, thus achieving reduction of the inrush current to a large capacitive load.

(4) Analog Control Input Terminal

The AEN input of the BD2270HFV is connected to a hysteresis comparator. Consequently, even analog signals can control the switching of the external N-Channel MOSFET.

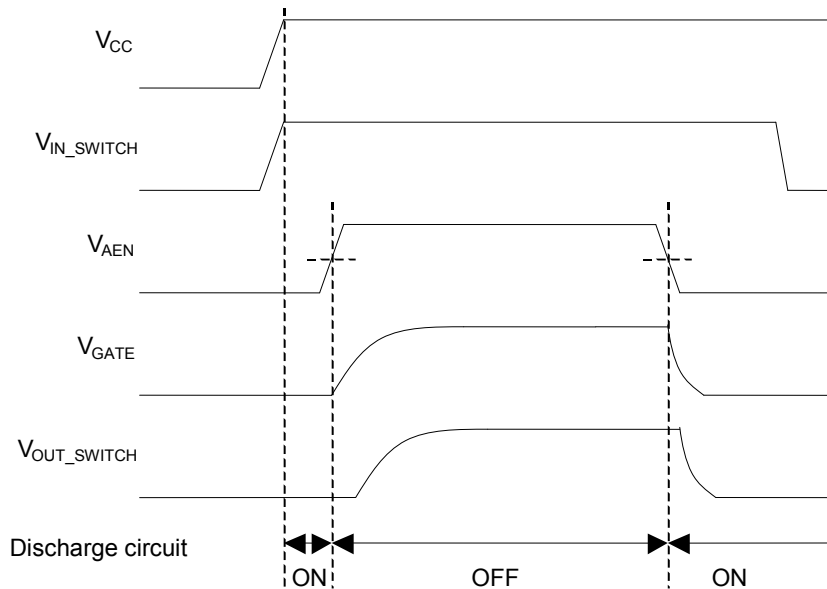
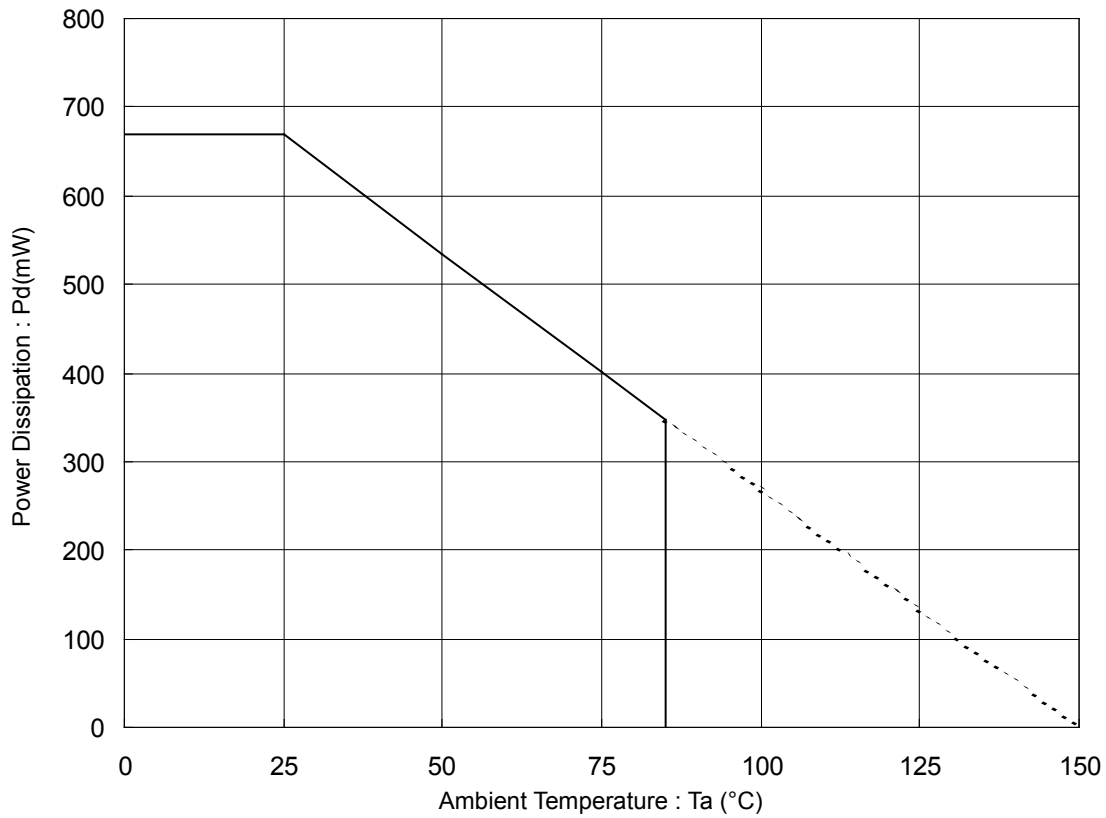

Figure 34. Operation Timing

To turn on the power supply (V_{CC} , V_{IN_SWITCH}), set the AEN to Low.

Power Dissipation

(HVSOF5)



(Mounted on a 70 mm x 70 mm x 1.6 mm glass epoxy board)

Figure 35. Power Dissipation Curve (Pd-Ta Curve)

I/O Equivalence Circuit

Pin Name	Pin No.	Equivalence Circuit
AEN	3	
DISC	4	
GATE	5	

Operational Notes

1. Reverse Connection of Power Supply

Connecting the power supply in reverse polarity can damage the IC. Take precautions against reverse polarity when connecting the power supply, such as mounting an external diode between the power supply and the IC's power supply pins.

2. Power Supply Lines

Design the PCB layout pattern to provide low impedance supply lines. Separate the ground and supply lines of the digital and analog blocks to prevent noise in the ground and supply lines of the digital block from affecting the analog block. Furthermore, connect a capacitor to ground at all power supply pins. Consider the effect of temperature and aging on the capacitance value when using electrolytic capacitors.

3. Ground Voltage

Ensure that no pins are at a voltage below that of the ground pin at any time, even during transient condition.

4. Ground Wiring Pattern

When using both small-signal and large-current ground traces, the two ground traces should be routed separately but connected to a single ground at the reference point of the application board to avoid fluctuations in the small-signal ground caused by large currents. Also ensure that the ground traces of external components do not cause variations on the ground voltage. The ground lines must be as short and thick as possible to reduce line impedance.

5. Thermal Consideration

Should by any chance the power dissipation rating be exceeded the rise in temperature of the chip may result in deterioration of the properties of the chip. The absolute maximum rating of the Pd stated in this specification is when the IC is mounted on a 70mm x 70mm x 1.6mm glass epoxy board. In case of exceeding this absolute maximum rating, increase the board size and copper area to prevent exceeding the Pd rating.

6. Recommended Operating Conditions

These conditions represent a range within which the expected characteristics of the IC can be approximately obtained. The electrical characteristics are guaranteed under the conditions of each parameter.

7. Inrush Current

When power is first supplied to the IC, it is possible that the internal logic may be unstable and inrush current may flow instantaneously due to the internal powering sequence and delays, especially if the IC has more than one power supply. Therefore, give special consideration to power coupling capacitance, power wiring, width of ground wiring, and routing of connections.

8. Operation Under Strong Electromagnetic Field

Operating the IC in the presence of a strong electromagnetic field may cause the IC to malfunction.

9. Testing on Application Boards

When testing the IC on an application board, connecting a capacitor directly to a low-impedance output pin may subject the IC to stress. Always discharge capacitors completely after each process or step. The IC's power supply should always be turned off completely before connecting or removing it from the test setup during the inspection process. To prevent damage from static discharge, ground the IC during assembly and use similar precautions during transport and storage.

10. Inter-pin Short and Mounting Errors

Ensure that the direction and position are correct when mounting the IC on the PCB. Incorrect mounting may result in damaging the IC. Avoid nearby pins being shorted to each other especially to ground, power supply and output pin. Inter-pin shorts could be due to many reasons such as metal particles, water droplets (in very humid environment) and unintentional solder bridge deposited in between pins during assembly to name a few.

Operational Notes - continued

11. Unused Input Pins

Input pins of an IC are often connected to the gate of a MOS transistor. The gate has extremely high impedance and extremely low capacitance. If left unconnected, the electric field from the outside can easily charge it. The small charge acquired in this way is enough to produce a significant effect on the conduction through the transistor and cause unexpected operation of the IC. So unless otherwise specified, unused input pins should be connected to the power supply or ground line.

12. Regarding the Input Pin of the IC

This monolithic IC contains P+ isolation and P substrate layers between adjacent elements in order to keep them isolated. P-N junctions are formed at the intersection of the P layers with the N layers of other elements, creating a parasitic diode or transistor. For example (refer to figure below):

When $GND > Pin A$ and $GND > Pin B$, the P-N junction operates as a parasitic diode.

When $GND > Pin B$, the P-N junction operates as a parasitic transistor.

Parasitic diodes inevitably occur in the structure of the IC. The operation of parasitic diodes can result in mutual interference among circuits, operational faults, or physical damage. Therefore, conditions that cause these diodes to operate, such as applying a voltage lower than the GND voltage to an input pin (and thus to the P substrate) should be avoided.

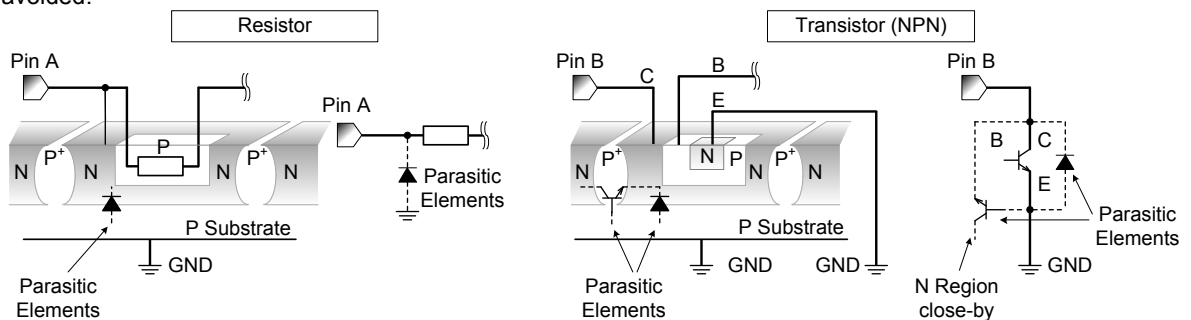

Figure 36. Example of monolithic IC structure

13. Ceramic Capacitor

When using a ceramic capacitor, determine the dielectric constant considering the change of capacitance with temperature and the decrease in nominal capacitance due to DC bias and others.

14. Thermal design

Perform thermal design in which there are adequate margins by taking into account the power dissipation (P_d) in actual states of use.

Ordering Information

B D 2 2 7 0 H F V - G T R

Part Number

Package
HFV: HVSOF5

Packaging and forming specification
G: Halogen Free
TR: Embossed tape and reel

Marking Diagram

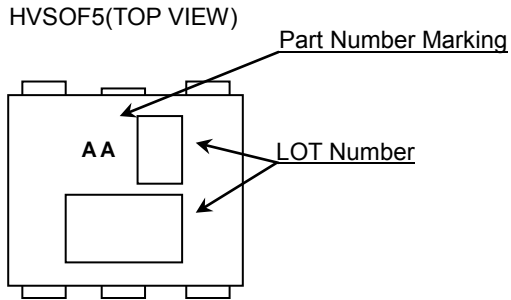

Physical Dimension Tape and Reel Information

Package Name	HVSOF5
--------------	--------

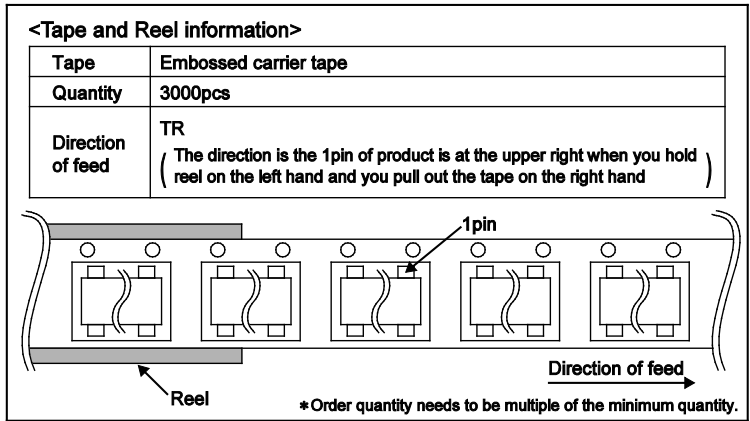
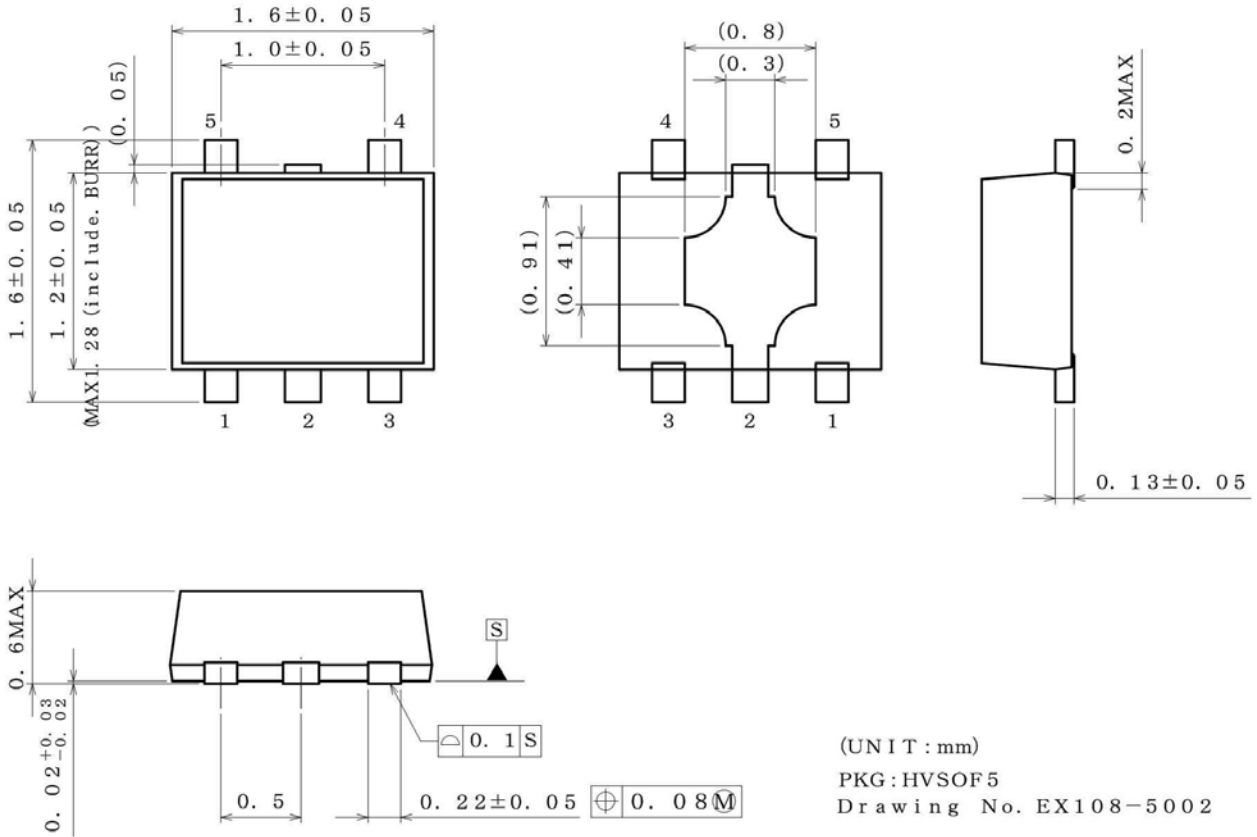

Revision History

Date	Revision	Changes
11.Mar.2013	001	New Release
25.Jun.2013	002	Modified figure 34.
21.Aug.2014	003	Applied the ROHM Standard Style and improved understandability.

Notice

Precaution on using ROHM Products

- Our Products are designed and manufactured for application in ordinary electronic equipments (such as AV equipment, OA equipment, telecommunication equipment, home electronic appliances, amusement equipment, etc.). If you intend to use our Products in devices requiring extremely high reliability (such as medical equipment ^(Note 1), transport equipment, traffic equipment, aircraft/spacecraft, nuclear power controllers, fuel controllers, car equipment including car accessories, safety devices, etc.) and whose malfunction or failure may cause loss of human life, bodily injury or serious damage to property ("Specific Applications"), please consult with the ROHM sales representative in advance. Unless otherwise agreed in writing by ROHM in advance, ROHM shall not be in any way responsible or liable for any damages, expenses or losses incurred by you or third parties arising from the use of any ROHM's Products for Specific Applications.

(Note1) Medical Equipment Classification of the Specific Applications

JAPAN	USA	EU	CHINA
CLASS III	CLASS III	CLASS II b	CLASS III
CLASS IV		CLASS III	

- ROHM designs and manufactures its Products subject to strict quality control system. However, semiconductor products can fail or malfunction at a certain rate. Please be sure to implement, at your own responsibilities, adequate safety measures including but not limited to fail-safe design against the physical injury, damage to any property, which a failure or malfunction of our Products may cause. The following are examples of safety measures:
 - Installation of protection circuits or other protective devices to improve system safety
 - Installation of redundant circuits to reduce the impact of single or multiple circuit failure
- Our Products are designed and manufactured for use under standard conditions and not under any special or extraordinary environments or conditions, as exemplified below. Accordingly, ROHM shall not be in any way responsible or liable for any damages, expenses or losses arising from the use of any ROHM's Products under any special or extraordinary environments or conditions. If you intend to use our Products under any special or extraordinary environments or conditions (as exemplified below), your independent verification and confirmation of product performance, reliability, etc. prior to use, must be necessary:
 - Use of our Products in any types of liquid, including water, oils, chemicals, and organic solvents
 - Use of our Products outdoors or in places where the Products are exposed to direct sunlight or dust
 - Use of our Products in places where the Products are exposed to sea wind or corrosive gases, including Cl₂, H₂S, NH₃, SO₂, and NO₂
 - Use of our Products in places where the Products are exposed to static electricity or electromagnetic waves
 - Use of our Products in proximity to heat-producing components, plastic cords, or other flammable items
 - Sealing or coating our Products with resin or other coating materials
 - Use of our Products without cleaning residue of flux (even if you use no-clean type fluxes, cleaning residue of flux is recommended); or Washing our Products by using water or water-soluble cleaning agents for cleaning residue after soldering
 - Use of the Products in places subject to dew condensation
- The Products are not subject to radiation-proof design.
- Please verify and confirm characteristics of the final or mounted products in using the Products.
- In particular, if a transient load (a large amount of load applied in a short period of time, such as pulse. is applied, confirmation of performance characteristics after on-board mounting is strongly recommended. Avoid applying power exceeding normal rated power; exceeding the power rating under steady-state loading condition may negatively affect product performance and reliability.
- De-rate Power Dissipation (Pd) depending on Ambient temperature (Ta). When used in sealed area, confirm the actual ambient temperature.
- Confirm that operation temperature is within the specified range described in the product specification.
- ROHM shall not be in any way responsible or liable for failure induced under deviant condition from what is defined in this document.

Precaution for Mounting / Circuit board design

- When a highly active halogenous (chlorine, bromine, etc.) flux is used, the residue of flux may negatively affect product performance and reliability.
- In principle, the reflow soldering method must be used; if flow soldering method is preferred, please consult with the ROHM representative in advance.

For details, please refer to ROHM Mounting specification

Precautions Regarding Application Examples and External Circuits

1. If change is made to the constant of an external circuit, please allow a sufficient margin considering variations of the characteristics of the Products and external components, including transient characteristics, as well as static characteristics.
2. You agree that application notes, reference designs, and associated data and information contained in this document are presented only as guidance for Products use. Therefore, in case you use such information, you are solely responsible for it and you must exercise your own independent verification and judgment in the use of such information contained in this document. ROHM shall not be in any way responsible or liable for any damages, expenses or losses incurred by you or third parties arising from the use of such information.

Precaution for Electrostatic

This Product is electrostatic sensitive product, which may be damaged due to electrostatic discharge. Please take proper caution in your manufacturing process and storage so that voltage exceeding the Products maximum rating will not be applied to Products. Please take special care under dry condition (e.g. Grounding of human body / equipment / solder iron, isolation from charged objects, setting of ionizer, friction prevention and temperature / humidity control).

Precaution for Storage / Transportation

1. Product performance and soldered connections may deteriorate if the Products are stored in the places where:
 - [a] the Products are exposed to sea winds or corrosive gases, including Cl₂, H₂S, NH₃, SO₂, and NO₂
 - [b] the temperature or humidity exceeds those recommended by ROHM
 - [c] the Products are exposed to direct sunshine or condensation
 - [d] the Products are exposed to high Electrostatic
2. Even under ROHM recommended storage condition, solderability of products out of recommended storage time period may be degraded. It is strongly recommended to confirm solderability before using Products of which storage time is exceeding the recommended storage time period.
3. Store / transport cartons in the correct direction, which is indicated on a carton with a symbol. Otherwise bent leads may occur due to excessive stress applied when dropping of a carton.
4. Use Products within the specified time after opening a humidity barrier bag. Baking is required before using Products of which storage time is exceeding the recommended storage time period.

Precaution for Product Label

QR code printed on ROHM Products label is for ROHM's internal use only.

Precaution for Disposition

When disposing Products please dispose them properly using an authorized industry waste company.

Precaution for Foreign Exchange and Foreign Trade act

Since our Products might fall under controlled goods prescribed by the applicable foreign exchange and foreign trade act, please consult with ROHM representative in case of export.

Precaution Regarding Intellectual Property Rights

1. All information and data including but not limited to application example contained in this document is for reference only. ROHM does not warrant that foregoing information or data will not infringe any intellectual property rights or any other rights of any third party regarding such information or data. ROHM shall not be in any way responsible or liable for infringement of any intellectual property rights or other damages arising from use of such information or data.:
2. No license, expressly or implied, is granted hereby under any intellectual property rights or other rights of ROHM or any third parties with respect to the information contained in this document.

Other Precaution

1. This document may not be reprinted or reproduced, in whole or in part, without prior written consent of ROHM.
2. The Products may not be disassembled, converted, modified, reproduced or otherwise changed without prior written consent of ROHM.
3. In no event shall you use in any way whatsoever the Products and the related technical information contained in the Products or this document for any military purposes, including but not limited to, the development of mass-destruction weapons.
4. The proper names of companies or products described in this document are trademarks or registered trademarks of ROHM, its affiliated companies or third parties.

General Precaution

1. Before you use our Products, you are requested to carefully read this document and fully understand its contents. ROHM shall not be in any way responsible or liable for failure, malfunction or accident arising from the use of any ROHM's Products against warning, caution or note contained in this document.
2. All information contained in this document is current as of the issuing date and subject to change without any prior notice. Before purchasing or using ROHM's Products, please confirm the latest information with a ROHM sales representative.
3. The information contained in this document is provided on an "as is" basis and ROHM does not warrant that all information contained in this document is accurate and/or error-free. ROHM shall not be in any way responsible or liable for any damages, expenses or losses incurred by you or third parties resulting from inaccuracy or errors of or concerning such information.

X-ON Electronics

Largest Supplier of Electrical and Electronic Components

Click to view similar products for [Gate Drivers](#) category:

Click to view products by [ROHM](#) manufacturer:

Other Similar products are found below :

[00053P0231](#) [56956](#) [57.404.7355.5](#) [LT4936](#) [57.904.0755.0](#) [5882900001](#) [00600P0005](#) [00-9050-LRPP](#) [00-9090-RDPP](#) [5951900000](#) [01-1003W-10/32-15](#) [0131700000](#) [00-2240](#) [LTP70N06](#) [LVP640](#) [5J0-1000LG-SIL](#) [LY1D-2-5S-AC120](#) [LY2-US-AC240](#) [LY3-UA-DC24](#) [00576P0020](#) [00600P0010](#) [LZN4-UA-DC12](#) [LZNQ2M-US-DC5](#) [LZNQ2-US-DC12](#) [LZP40N10](#) [00-8196-RDPP](#) [00-8274-RDPP](#) [00-8275-RDNP](#) [00-8722-RDPP](#) [00-8728-WHPP](#) [00-8869-RDPP](#) [00-9051-RDPP](#) [00-9091-LRPP](#) [00-9291-RDPP](#) [0207100000](#) [0207400000](#) [01312](#) [0134220000](#) [60713816](#) [M15730061](#) [61161-90](#) [61278-0020](#) [6131-204-23149P](#) [6131-205-17149P](#) [6131-209-15149P](#) [6131-218-17149P](#) [6131-220-21149P](#) [6131-260-2358P](#) [6131-265-11149P](#) [CS1HCPU63](#)