

CONFIDENTIAL

構造 (Structure):	シリコンモノリシック集積回路 (Silicon Monolithic Integrated Circuit)	
製品名 (Product):	カーオーディオ用サウンド・プロセッサ (Sound Processor for car audio)	
形名 (Type):	BD3702FV	
外形寸法図 (Outside Dimension):	Fig-1	(Page. 5/35)
ブロック図 (Block Diagram):	Fig-2	(Page. 6/35)
測定回路図 (Measurement Circuit Diagram):	Fig-3	(Page. 10, 11/35)
タイミングチャート (Timing Chart):	Fig-4(I ² C BUS)	(Page. 15/35)
応用回路例 (Application Circuit Diagram):	Fig-5	(Page. 32/35)

この文書の扱いについて

この文書の日本語版が正式な仕様書です。この文書の翻訳版は、正式な仕様書を読むための参考としてください。
なお、相違が生じた場合は、正式な仕様書を優先してください。

Status of this document

The Japanese version of this document is the formal specification. A customer may use this translation only for a reference to help reading the formal version. If there are any differences in translation version of this document, formal version takes priority.

※耐放射線設計はしていません。 Design against radiation-proof isn't made.

使用上の注意

応用回路例は推奨すべきものと確信しておりますが、ご使用にあたっては更に特性のご確認を十分に願います。

外付回路定数を変更してご使用になる時は、静特性のみならず過渡特性も含め外付部品及び当社ICのバラツキ等を考慮して十分なマージンを見て決定してください。

また、特許権に関しましては当社では十分な確認は出来ておりませんので御了承ください。

本製品は、一般的な電子機器への使用を意図しています。

極めて高度な信頼性が要求され、その製品の故障や誤動作が直接人命に関わるような機器・装置へのご使用を検討される際は、事前に弊社営業窓口までご相談願います。

本仕様に掲載しております応用回路等は製品の特性及び性能を引き出す上で正確かつ信頼できるものと確信しております。

ただしその使用に起因する回路上及び工業所有権に関する諸問題につきましては当社は一切その責任を負いません。

Application example

The application circuit is recommended for use. Make sure to confirm the adequacy of the characteristics.

When using the circuit with changes to the external circuit constants, make sure to leave an adequate margin for external components including static and transitional characteristics as well as dispersion of the IC.

Note that ROHM cannot provide adequate confirmation of patents.

The product described in this specification is designed to be used with ordinary electronic equipment or devices (such as audio-visual equipment, office-automation equipment, communications devices, electrical appliances, and electronic toys).

Should you intend to use this product with equipment or devices which require an extremely high level of reliability and the malfunction of which would directly endanger human life (such as medical instruments, transportation equipment, aerospace machinery, nuclear-reactor controllers, fuel controllers and other safety devices), please be sure to consult with our sales representative in advance.

ROHM assumes no responsibility for use of any circuits described herein, conveys no license under any patent or other right, and makes no representations that the circuits are free from patent infringement.

DESIGN	CHECK	APPROVAL	DATE: 2008/4/25	SPECIFICATION No. TARGET SPECIFICATION
			REV. 0.1	ROHM CO.,LTD.

機能 (Function):

Function	Specifications																				
Input selector	<ul style="list-style-type: none"> ・ステレオ入力 (Stereo input) ・Single-End/Diff/Full-Diff 数を下表の通り設定可能 (Possible to set the number of single-end/diff/full-diff as follows) <table border="1" style="margin-left: auto; margin-right: auto;"> <thead> <tr> <th></th> <th>Single-End</th> <th>Differential</th> <th>Full-Differential</th> </tr> </thead> <tbody> <tr> <td>Mode 1</td> <td>3</td> <td>1</td> <td>1</td> </tr> <tr> <td>Mode 2</td> <td>4</td> <td>0</td> <td>1</td> </tr> <tr> <td>Mode 3</td> <td>5</td> <td>1</td> <td>0</td> </tr> <tr> <td>Mode 4</td> <td>6</td> <td>0</td> <td>0</td> </tr> </tbody> </table> <p style="text-align: center;">Table.1 Combination of input selector</p>		Single-End	Differential	Full-Differential	Mode 1	3	1	1	Mode 2	4	0	1	Mode 3	5	1	0	Mode 4	6	0	0
	Single-End	Differential	Full-Differential																		
Mode 1	3	1	1																		
Mode 2	4	0	1																		
Mode 3	5	1	0																		
Mode 4	6	0	0																		
Input gain	<ul style="list-style-type: none"> ・0~20dB (1dB step) ・切替ショック音防止技術“アドバンスト・スイッチ”対応 (Possible to use “Advanced switch” for prevention of switching noise.) 																				
Mute	<ul style="list-style-type: none"> ・切替ショック音防止技術“アドバンスト・スイッチ”対応 (Possible to use “Advanced switch” for prevention of switching noise.) 																				
Volume	<ul style="list-style-type: none"> ・+15dB~-79dB (1dB step), -∞ ・切替ショック音防止技術“アドバンスト・スイッチ”対応 (Possible to use “Advanced switch” for prevention of switching noise.) 																				
Bass	<ul style="list-style-type: none"> ・-20~+20dB (1dB step) ・Q=0.5, 1, 1.5, 2 ・fo=60, 80, 100, 120Hz ・ゲイン切替え時においてアドバンスト・スイッチ対応 (Possible to use advanced switch at changing gain) 																				
Middle	<ul style="list-style-type: none"> ・-20~+20dB (1dB step) ・Q=0.75, 1, 1.25, 1.5 ・fo=500, 1k, 1.5k, 2.5kHz ・ゲイン切替え時においてアドバンスト・スイッチ対応 (Possible to use advanced switch at changing gain) 																				
Treble	<ul style="list-style-type: none"> ・-20~+20dB (1dB step) ・Q=0.75, 1.25 ・fo=7.5k, 10k, 12.5k, 15kHz ・ゲイン切替え時においてアドバンスト・スイッチ対応 (Possible to use advanced switch at changing gain) 																				
Fader	<ul style="list-style-type: none"> ・+15dB~-79dB (1dB step), -∞dB ・切替ショック音防止技術“アドバンスト・スイッチ”対応 (Possible to use “Advanced switch” for prevention of switching noise.) 																				
Loudness	<ul style="list-style-type: none"> ・0dB~20dB (1dB step) ・fo=250/400/800Hz ・切替ショック音防止技術“アドバンスト・スイッチ”対応 (Possible to use “Advanced switch” for prevention of switching noise.) 																				
LPF	<ul style="list-style-type: none"> ・fc=55/85/120Hz, pass ・位相切替 (Phase shift) (0° /180°) 																				
Level meter	<ul style="list-style-type: none"> ・I2C BUS 制御 (I2C BUS control) ・DC 出力 (DC Output) 																				
Mixing	<ul style="list-style-type: none"> ・モノラル入力 (Monaural input) ・+7dB~-79dB (1dB step), -∞ ・切替ショック音防止技術“アドバンスト・スイッチ”対応 (Possible to use “Advanced switch” for prevention of switching noise.) 																				

特徴 (Feature):

1. シングルエンド入力／差動入力数を各種設定できる入力セクタ回路内蔵
(Built-in differential input selector that can make various combination of single-ended / differential input.)
2. アドバンスド・スイッチ回路により入力ゲインコントロール、ミュート、メインボリューム、フェダーボリューム、バス、ミドル、トレブル、ラウドネス、ミキシングのゲイン・減衰量の切換ノイズを軽減(全ステップ対応)
(Reduce switching noise of input gain control, mute, main volume, fader volume, bass, middle, treble, loudness, mixing by using advanced switch circuit [Possible to control all steps])
3. 3バンド・イコライザ用フィルタ、サブウーハ用 LPF、ラウドネス用フィルタを内蔵することにより外付け部品を大幅に削減し、Q、Gv、fo、fc を I²C BUS 制御により自由自在に制御することが可能
(Decrease the number of external components by built-in 3-band equalizer filter, LPF for subwoofer, loudness filter. And, possible to control Q, Gv, fo of 3-band equalizer and fc of LPF, fo, Gv of loudness by I²C BUS control freely)
4. サブウーハ出力用端子を装備し、I²C BUS コントロールによりフロント/リアのステレオ信号出力が選択可能
(It is equipped with output terminals of Subwoofer. Moreover, the stereo signal of the front and rear also can be output by the I²C BUS control.)
5. バス、ミドル、トレブルはゲイン調整幅±20dB、1dB ステップ
(It is possible for the bass, middle, treble to the gain adjustment quantity of ±20dB and 1 dB step gain adjustment.)
6. Bi-CMOS プロセスを使用し、低消費電流で省エネルギー設計に最適となっており、セット内部のレギュレータの小規模化や発熱に対してより品質的に有利
(Bi-CMOS process is suitable for the design of low current and low energy. And it provides more quality for small scale regulator and heat in a set.)
7. 外部ステレオ音声入口に最適なグラウンド・アイソレーション・アンプ入力を内蔵
(Built-in ground isolation amplifier inputs, ideal for external stereo input.)
8. 携帯オーディオ入力用ボリュームとして使用可能な切換ノイズ対策入力ゲインコントロールを内蔵
(Built-in input gain controller reduce switching noise for volume of a portable audio input.)
9. ミキシング入力、ミキシング ATT 内蔵
(Built-in mixing input and mixing attenuation.)
10. パッケージに SSOP-B28 を使用。音声入力端子、音声出力端子をそれぞれまとめて配置し、信号の流れを一方向に揃えていることが基板パターンのレイアウトを容易にし、基板面積の削減に貢献
(Package is SSOP-B28. Putting input-terminals together and output-terminals together can make PCB layout easier and can makes area of PCB smaller.)
11. I²C BUS は、3.3V / 5V に対応
(It is possible to control by 3.3V / 5V for I²C BUS.)

用途(The use):

カーオーディオに最適。その他、ミニコンポ、マイクロコンポ、TVなどの各種オーディオ機器に使用可能。
It is the optimal for the car audio. Besides, it is possible to use for the audio equipment of mini Compo, micro Compo, TV etc with all kinds.

絶対最大定格 (Absolute Maximum Ratings) (Ta=25°C)

項目 (Item)	記号 (Symbol)	定格 (Rating)	単位 (Unit)
電源電圧 (Power supply Voltage)	VCC	10.0	V
入力電圧 (Input voltage)	Vin	VCC+0.3~GND-0.3	V
許容損失 (Power Dissipation)	Pd	1063 ※1	mW
保存温度範囲 (Storage Temperature)	Tastg	-55~+150	°C

※1 Ta=25°C以上は 8.5mW/°Cで軽減(This value decreases 8.5mW/°C for Ta=25°C or more.).
 ローム標準基板装着時(ROHM standard board shall be mounted.)。熱抵抗(Thermal resistance) $\theta_{ja} = 117.6(^{\circ}\text{C}/\text{W})$ 。
 ローム標準基板 サイズ(Size): 70 × 70 × 1.6(mm)
 (ROHM Standard board) 材 質: FR4 ガラス-エポキシ基板(銅箔面積 3%以下)
 material: A FR4 glass epoxy board(3% or less of copper foil area)

動作範囲 (Operating Range)

項目 (Item)	記号 (Symbol)	MIN	TYP	MAX	単位
電源電圧 (Power supply Voltage)	VCC	7.0	-	9.5	V
温度 (Temperature)	Topr	-40	-	+85	V

CONFIDENTIAL

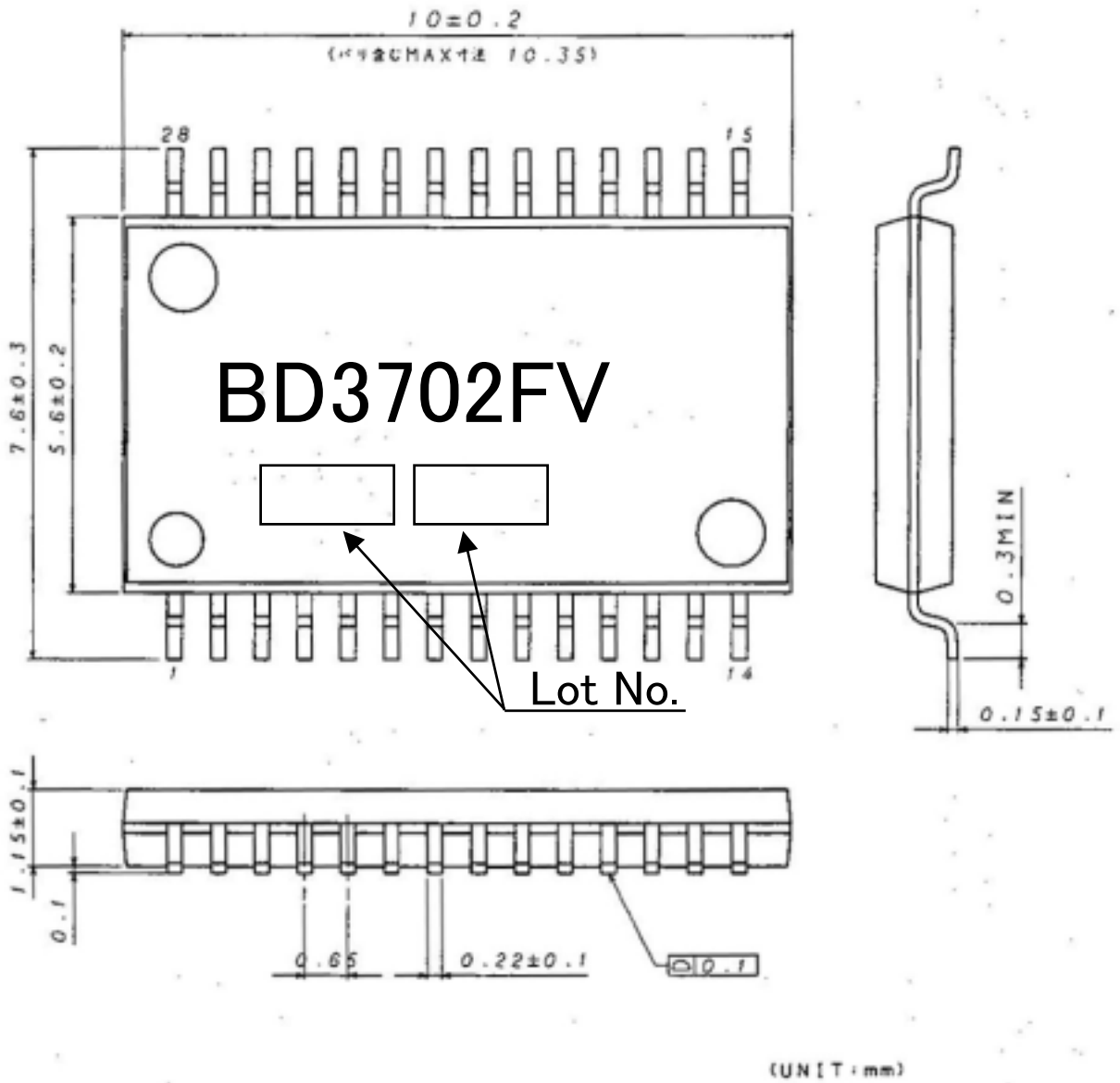

Fig-1 外形寸法図 (Outside dimension)

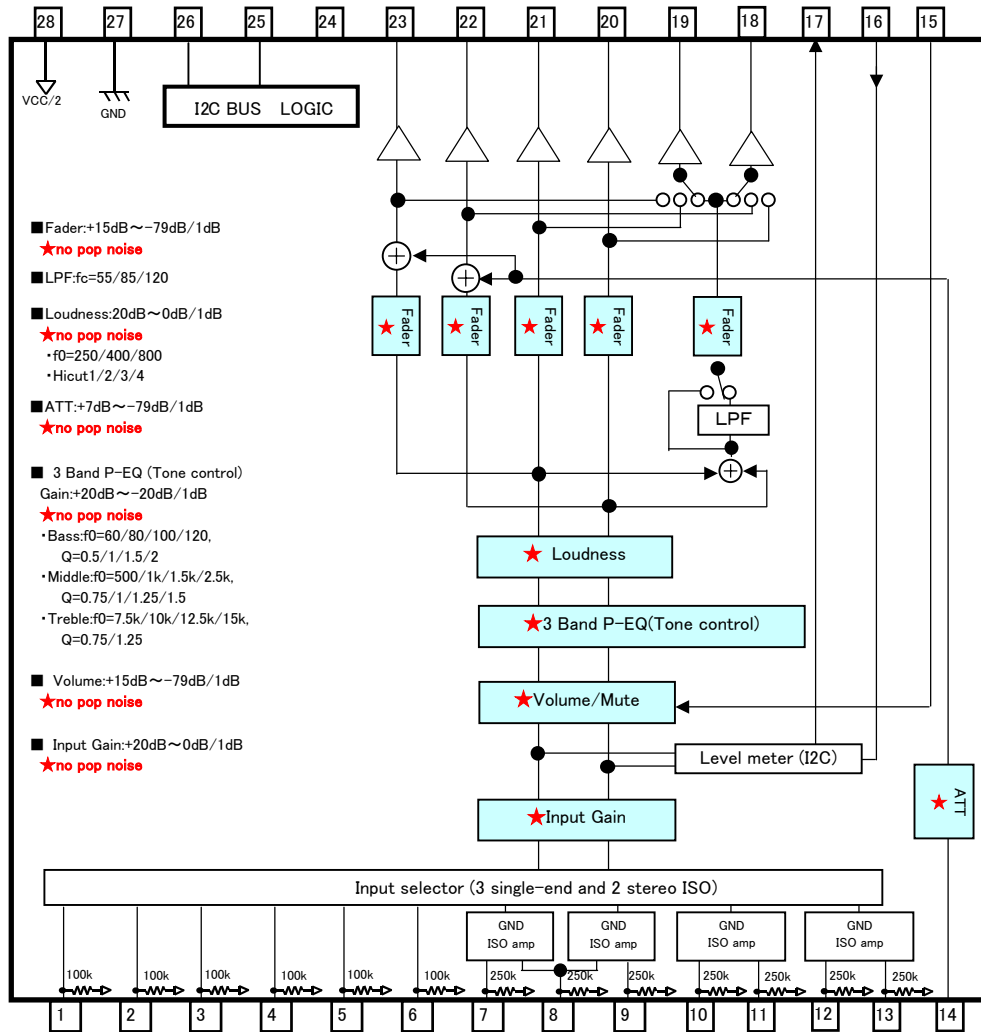

Fig-2 ブロック図 (Block Diagram)

端子説明 (Descriptions of terminal)

端子番号 Terminal No.	端子名 Terminal Name	端子説明 Description	端子番号 Terminal No.	端子名 Terminal Name	端子説明 Description
1	A1	A input terminal of 1ch	15	MUTE	External compulsory mute terminal
2	A2	A input terminal of 2ch	16	LRST	Level meter reset terminal
3	B1	B input terminal of 1ch	17	LOUT	Output terminal for Level meter
4	B2	B input terminal of 2ch	18	OUTS2	Subwoofer output terminal of 2ch
5	C1	C input terminal of 1ch	19	OUTS1	Subwoofer output terminal of 1ch
6	C2	C input terminal of 2ch	20	OUTR2	Rear output terminal of 2ch
7	DP1	D positive input terminal of 1ch	21	OUTR1	Rear output terminal of 1ch
8	DN	D negative input terminal	22	OUTF2	Front output terminal of 2ch
9	DP2	D positive input terminal of 2ch	23	OUTF1	Front output terminal of 1ch
10	EP1	E positive input terminal of 1ch	24	VCC	Power supply terminal
11	EN1	E negative input terminal of 1ch	25	SCL	I ² C Communication clock terminal
12	EN2	E negative input terminal of 2ch	26	SDA	I ² C Communication data terminal
13	EP2	E positive input terminal of 2ch	27	GND	GND terminal
14	MIN	Mixing input terminal	28	FIL	VCC/2 terminal

電気的特性 (Electrical Characteristic)

(Unless specified particularly, Ta=25°C, VCC=8.5V, f=1kHz, Vin=1Vrms, Rg=600Ω, RL=10kΩ, A1 input, Input gain 0dB, Mute off, Volume 0dB, Tone control 0dB, Loudness 0dB, LPF OFF, Mixing OFF, Fader 0dB)

BLOCK	項目 Item	記号 Symbol	規格値 Limit			単位 Unit	条件 Condition
			最小 Min.	標準 Typ.	最大 Max.		
GENERAL	無信号時回路電流 Current upon no signal	I _Q	—	48	60	mA	No signal
	電圧利得 Voltage gain	G _V	-1.5	0	1.5	dB	G _V =20log(VOUT/VIN)
	チャンネルバランス Channel balance	CB	-1.5	0	1.5	dB	CB = GV1-GV2
	全高調波歪率 1(FRONT,REAR) Total harmonic distortion 1	THD+N1	—	0.001	0.05	%	VOUT=1Vrms BW=400-30KHz
	全高調波歪率 2(SUBWOOFER) Total harmonic distortion 2	THD+N2	—	0.002	0.05	%	VOUT=1Vrms BW=400-30KHz
	出力雑音電圧 1(FRONT,REAR) * Output noise voltage 1	V _{NO1}	—	3.8	15	μVrms	Rg = 0Ω BW = IHF-A
	出力雑音電圧 2(SUBWOOFER) * Output noise voltage 2	V _{NO2}	—	4.8	15	μVrms	Rg = 0Ω BW = IHF-A
	残留雑音電圧 * Residual output noise voltage	V _{NOR}	—	1.8	10	μVrms	Fader = -∞dB Rg = 0Ω BW = IHF-A
	チャンネル間クロストーク * Cross-talk between channels	CTC	—	-100	-90	dB	Rg = 0Ω CTC=20log(VOUT/VIN) BW = IHF-A
	リップルリジェクション Ripple rejection	RR	—	-70	-40	dB	f=1kHz VRR=100mVrms RR=20log(VCC IN/VOUT)
INPUT SELECTOR	入力インピーダンス(A, B, C) Input impedance(A, B, C)	R _{IN,S}	70	100	130	kΩ	
	入力インピーダンス(D, E) Input impedance (D, E)	R _{IN,D}	175	250	325	kΩ	
	最大入力電圧 Maximum input voltage	V _{IM}	2.1	2.3	—	Vrms	VIM at THD+N(VOUT)=1% BW=400-30KHz
	セレクタ間クロストーク * Cross-talk between selectors	CTS	—	-100	-90	dB	Rg = 0Ω CTS=20log(VOUT/VIN) BW = IHF-A
	同相除去比(D, E) * Common mode rejection ratio (D, E)	CMRR	50	65	—	dB	XP1 and XN input XP2 and XN input CMRR=20log(VIN/VOUT) BW = IHF-A,[※X・・・D,E]
INPUT GAIN	最小入力ゲイン Minimum input gain	G _{IN MIN}	-2	0	+2	dB	Input gain 0dB VIN=100mVrms G _{in} =20log(VOUT/VIN)
	最大入力ゲイン Maximum input gain	G _{IN MAX}	18	20	22	dB	Input gain 20dB VIN=100mVrms G _{in} =20log(VOUT/VIN)
	ゲイン設定誤差 Gain set error	G _{IN ERR}	-2	0	+2	dB	GAIN=+1~+20dB

BLOCK	項目 Item	記号 Symbol	規格値 Limit			単位 Unit	条件 Condition
			最小 Min.	標準 Typ.	最大 Max.		
MUTE	ミュート減衰量 * Mute attenuation	G_{MUTE}	—	-105	-85	dB	Mute ON $G_{mute}=20\log(V_{OUT}/V_{IN})$ BW = IHF-A
VOLUME	最大ゲイン Maximum gain	$G_{V MAX}$	13	15	17	dB	Volume = 15dB $V_{IN}=100mV_{rms}$ $G_v=20\log(V_{OUT}/V_{IN})$
	最大減衰量 * Maximum attenuation	$G_{V MIN}$	—	-100	-85	dB	Volume = $-\infty$ dB $G_v=20\log(V_{OUT}/V_{IN})$ BW = IHF-A
	減衰量設定誤差 1 Attenuation set error 1	$G_{V ERR1}$	-2	0	2	dB	GAIN & ATT=+15dB~-15dB
	減衰量設定誤差 2 Attenuation set error 2	$G_{V ERR2}$	-3	0	3	dB	ATT=-16dB~-47dB
	減衰量設定誤差 3 Attenuation set error 3	$G_{V ERR3}$	-4	0	4	dB	ATT=-48dB~-79dB
BASS	最大ブーストゲイン Maximum boost gain	$G_{B BST}$	18	20	22	dB	Gain=+20dB f=100Hz $V_{IN}=100mV_{rms}$ $G_B=20\log(V_{OUT}/V_{IN})$
	最大カットゲイン Maximum cut gain	$G_{B CUT}$	-22	-20	-18	dB	Gain=-20dB f=100Hz $V_{IN}=2V_{rms}$ $G_B=20\log(V_{OUT}/V_{IN})$
	ゲイン設定誤差 Gain set error	$G_{B ERR}$	-2	0	2	dB	Gain=-20~+20dB f=100Hz
MIDDLE	最大ブーストゲイン Maximum boost gain	$G_{M BST}$	18	20	22	dB	Gain=+20dB f=1kHz $V_{IN}=100mV_{rms}$ $G_M=20\log(V_{OUT}/V_{IN})$
	最大カットゲイン Maximum cut gain	$G_{M CUT}$	-22	-20	-18	dB	Gain=-20dB f=1kHz $V_{IN}=2V_{rms}$ $G_M=20\log(V_{OUT}/V_{IN})$
	ゲイン設定誤差 Gain set error	$G_{M ERR}$	-2	0	2	dB	Gain=-20~+20dB f=1kHz
TREBLE	最大ブーストゲイン Maximum boost gain	$G_{T BST}$	17	20	23	dB	Gain=+20dB f=10kHz $V_{IN}=100mV_{rms}$
	最大カットゲイン Maximum cut gain	$G_{T CUT}$	-23	-20	-17	dB	Gain=-20dB f=10kHz $V_{IN}=2V_{rms}$
	ゲイン設定誤差 Gain set error	$G_{T ERR}$	-2	0	2	dB	Gain=-20~+20dB f=10kHz f=10kHz
MIXING	入力インピーダンス Input impedance	$R_{IN,M}$	19	27	35	k Ω	
	最大入力電圧 Maximum input voltage	$V_{IM,M}$	2.0	2.2	—	V _{rms}	VIM at THD+N(V _{OUT})=1% BW=400-30KHz
	最大減衰量 Maximum attenuation	$G_{MX MIN}$	—	-100	-85	dB	MIX=OFF $G_{MX}=20\log(V_{OUT}/V_{IN})$ BW=INF-A
	最大ゲイン Maximum gain	$G_{MX MAX}$	5	7	9	dB	ATT=+6dB $G_{MX}=20\log(V_{OUT}/V_{IN})$

BLOCK	項目 Item	記号 Symbol	規格値 Limit			単位 Unit	条件 Condition
			最小 Min.	標準 Typ.	最大 Max.		
FADER / SUBWOOFER	最大ブーストゲイン Maximum boost gain	$G_{F\text{ BST}}$	13	15	17	dB	Fader=15dB $V_{IN}=100\text{mVrms}$ $G_F=20\log(V_{OUT}/V_{IN})$
	最大減衰量 * Maximum attenuation	$G_{F\text{ MIN}}$	—	-100	-90	dB	Fader = $-\infty$ dB $G_F=20\log(V_{OUT}/V_{IN})$ BW = IHF-A
	ゲイン設定誤差 Gain set error	$G_{F\text{ ERR}}$	-2	0	2	dB	Gain=+1~-+15dB
	減衰量設定誤差 1 Attenuation set error 1	$G_{F\text{ ERR1}}$	-2	0	2	dB	ATT=-1~-15dB
	減衰量設定誤差 2 Attenuation set error 2	$G_{F\text{ ERR2}}$	-3	0	3	dB	ATT=-16~-47dB
	減衰量設定誤差 3 Attenuation set error 3	$G_{F\text{ ERR3}}$	-4	0	4	dB	ATT=-48~-79dB
	出力インピーダンス Output impedance	R_{OUT}	—	—	50	Ω	$V_{IN}=100\text{mVrms}$
最大出力電圧 Maximum output voltage	V_{OM}	2	2.2	—	Vrms	THD+N=1% BW=400-30KHz	
LOUDNESS	最大ゲイン Maximum gain	$G_{L\text{ MAX}}$	17	20	23	dB	Gain 20dB $V_{IN}=100\text{mVrms}$ $G_L=20\log(V_{OUT}/V_{IN})$
	ゲイン設定誤差 Gain set error	$G_{L\text{ ERR}}$	-2	0	2	dB	Gain=+1~-+20dB
Level meter	最大出力電圧 Maximum output voltage	$V_{L\text{ MAX}}$	2.8	3.1	3.5	V	
	出力オフセット電圧 Output offset voltage	$V_{L\text{ OFF}}$	—	0	100	mV	

※ 印の測定は松下通工製 VP-9690A (平均値検波、実効値表示) のフィルターを使用しています。

VP-9690A (Average value detection, effective value display) filter by Matsushita Communication is used for * measurement.

入出力信号端子間の位相関係は同位相です。Phase between input / output is same.

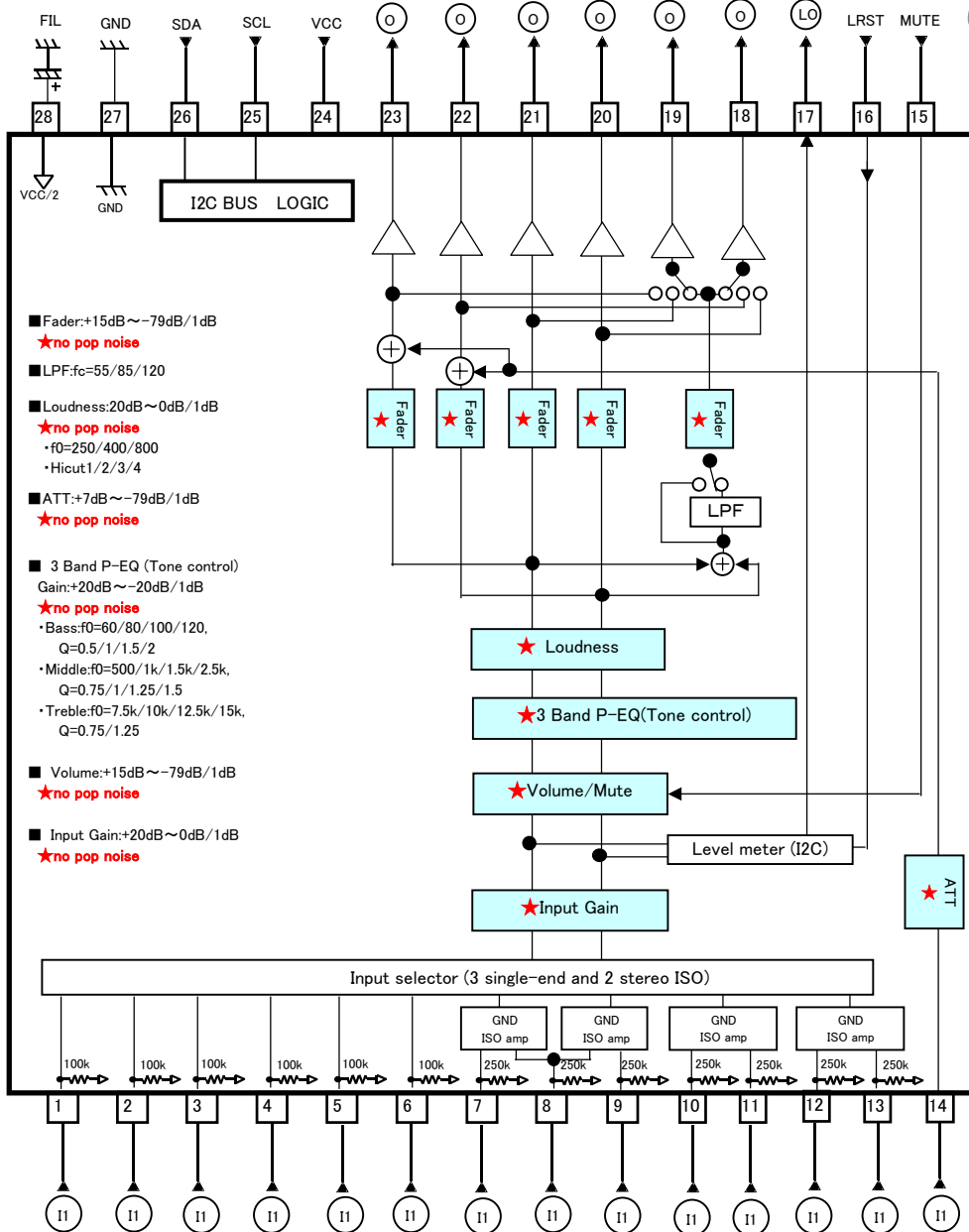

Fig-3 測定回路図 (Measurement Circuit Diagram)

UNIT
RESISTANCE : Ω
CAPACITANCE : F

測定回路の外付け部品について External Parts of Measuring circuit		
・抵抗	resistor	: ± 1%
・コンデンサ	capacitor	: ± 1%

- 配線上の注意 Notes on wiring**
- ① 電源のデカップリングコンデンサは、GND に対して、出来るだけ最短距離で接続してください。
Please connect the decoupling capacitor of a power supply in the shortest distance as much as possible to GND.
 - ② GND ラインは一点接続して下さい。
Lines of GND shall be one-point connected.
 - ③ Digital の配線パターンはアナログ部の配線パターンから離して、クロストークのないようにして下さい。
Wiring pattern of Digital shall be away from that of analog unit and cross-talk shall not be acceptable.
 - ④ I²C BUS 部の SCL, SDA ラインはなるべく平行に引かないで下さい。隣接する時はシールドするようにして下さい。
Lines of SCL and SDA of I²C BUS shall not be parallel if possible. The lines shall be shielded, if they are adjacent to each other.
 - ⑤ アナログ入力信号ラインはなるべく平行に引かないで下さい。隣接する時はシールドするようにして下さい。
Lines of analog input shall not be parallel if possible. The lines shall be shielded, if they are adjacent to each other.

Item	Test circuit	Condition	Connection terminal	
			Pin No.	Pin Name
Power Supply		$R_g=0\ \Omega$ $V_{RR}=100\text{mV}_{\text{rms}}$ $f_{RR}=100\text{Hz}$	24	VCC
INPUT1		$R=100\text{k}\ \Omega$ (1~6pin) $R=250\text{k}\ \Omega$ (7~13pin) $R=27\text{k}\ \Omega$ (14pin) $C=2.2\ \mu\text{F}$ (1~7,9,10,13, 14pin) $C=10\ \mu\text{F}$ (8,11,12pin) $R_g=600\ \Omega$	1 2 3 4 5 6 7 8 9	A1 A2 B1 EP1 B2 EN1 C1 EN2 C2 EP2 DP1 MIN DN DP2
OUTPUT		$R_{O1}=10\text{k}\ \Omega$ $R_{O2}=10\text{k}\ \Omega$ $C=4.7\ \mu\text{F}$	18 19 20 21 22 23	OUTS2 OUTS1 OUTR2 OUTR1 OUTF2 OUTF1
DC OUTPUT		$R=10\text{M}\ \Omega$	16	LOUT
MUTE		MUTE ON $V_{\text{MUTE}}=1.1\text{V}$ MUTE OFF $V_{\text{MUTE}}=2.2\text{V}$	15	MUTE
I ² C BUS		$f_{\text{clk}}=400\text{kHz}$ $V_{\text{IH}}=2.2\text{V}$ $V_{\text{IL}}=1.1\text{V}$ $R_{\text{OD}}=R_{\text{OC}}=680\ \Omega$ $V_{\text{DD}}=2.2\text{V}$	25 26	SCL SDA

※A measurement device and a power supply are ideal condition.

※It makes SW a default 0 condition.

測定スイッチ操作表 (SW control table for measurement)

(Unless specified particularly, the signal is inputted from A1 and measured at OUTF1. Measurement circuit diagram is Fig. 3.)

BLOCK	項目 Item	信号入力点 Signal input point	測定点 Measurement point	I ² C BUS データ (I ² C BUS Data)																				SW table								
				セレクトアドレス (Select Address)																				SW1	SW2	SW3						
				01(hex)	02(hex)	03(hex)	05(hex)	06(hex)	20(hex)	28(hex)	29(hex)	2A(hex)	2B(hex)	2C(hex)	30(hex)	41(hex)	44(hex)	47(hex)	51(hex)	54(hex)	57(hex)	75(hex)	90(hex)				F0(hex)	F1(hex)	FE(hex)			
GENERAL	無信号時回路電流 Current upon no signal	-	-	-	-	-	-	-	-	-	-	-	-	-	-	-	-	-	-	-	-	-	-	-	-	0	0	0				
	電圧利得 Voltage gain	A1	OUTF1	E4	00	01	00	00	80	80	80	80	80	80	80	FF	00	00	00	80	80	80	00	30	-	-	-	0	0	0		
	チャンネルバランス Channel balance	A1 A2	OUTF1 OUTF2	E4	00	01	00	00	80	80	80	80	80	80	80	FF	00	00	00	80	80	80	00	30	-	-	-	0	0	0		
	全高調波歪率 Total harmonic distortion	A1	OUTF1	E4	00	01	00	00	80	80	80	80	80	80	80	FF	00	00	00	80	80	80	00	30	-	-	-	0	0	0		
	出力雑音電圧 Output noise voltage	-	OUTF1	E4	00	01	00	00	80	80	80	80	80	80	80	FF	00	00	00	80	80	80	00	30	-	-	-	0	2	0		
	残留雑音電圧 Residual output noise voltage	-	OUTF1	E4	00	01	00	00	FF	FF	FF	FF	FF	FF	FF	FF	00	00	00	80	80	80	00	30	-	-	-	0	2	0		
	チャンネル間クロストーク Cross-talk between channels	A1	OUTF2	E4	00	01	00	00	80	80	80	80	80	80	80	80	FF	00	00	00	80	80	80	00	30	-	-	-	0	0 (A1) 2 (A1 以外)	0	
リップルリジェクション Ripple rejection	VCC	OUTF1	E4	00	01	00	00	80	80	80	80	80	80	80	80	FF	00	00	00	80	80	80	00	30	-	-	-	1	2	0		
INPUT SELECTOR	入力インピーダンス(A,B,C) Input impedance(A,B,C)	A1 ~ C2	OUTF1 OUTF2	E4	00	01	00 02	00	80	80	80	80	80	80	80	80	FF	00	00	00	80	80	80	00	30	-	-	-	0	1	0	
	入力インピーダンス(D,E) Input impedance(D,E)	DP1 ~ EP2	OUTF1 OUTF2	E4	00	01	06 08	00	80	80	80	80	80	80	80	80	FF	00	00	00	80	80	80	00	30	-	-	-	0	1	0	
	最大入力電圧 Maximum input voltage	A1	OUTF1	E4	00	01	00	00	80	80	80	80	80	80	80	80	FF	00	00	00	80	80	80	00	30	-	-	-	0	0	0	
	セレクト間クロストーク Cross-talk between selector	A1	OUTF1	E4	00	01	01 04 06 08 0A	00	80	80	80	80	80	80	80	80	80	FF	00	00	00	80	80	80	00	30	-	-	-	0	0 (A1) 2 (A1 以外)	0
	同相除去比(D,E) Common mode rejection ratio(D,E)	DP1	OUTF1	E4	00	01	06 08	00	80	80	80	80	80	80	80	80	80	FF	00	00	00	80	80	80	00	30	-	-	-	0	0	0
INPUT GAIN	最小入力ゲイン Minimum input gain	A1	OUTF1	E4	00	01	00	00	80	80	80	80	80	80	80	80	FF	00	00	00	80	80	80	00	30	-	-	-	0	0	0	
	最大入力ゲイン Maximum input gain	A1	OUTF1	E4	00	01	00	14	80	80	80	80	80	80	80	80	80	FF	00	00	00	80	80	80	00	30	-	-	-	0	0	0
	ゲイン設定誤差 Gain set error	A1	OUTF1	E4	00	01	00	01 14	80	80	80	80	80	80	80	80	80	80	FF	00	00	00	80	80	80	00	30	-	-	-	0	0
MIXING	入力インピーダンス Input impedance	MIN	OUTF1	E4	00	01	00	00	80	80	80	80	80	80	80	80	80	80	80	80	80	80	00	30	-	-	-	0	0	0		
	最大入力電圧 Maximum input voltage	MIN	OUTF1	E4	00	01	00	00	80	80	80	80	80	80	80	80	80	80	80	80	80	80	00	30	-	-	-	0	0	0		
	最大減衰量 Maximum attenuation	MIN	OUTF1	E4	00	01	00	01 14	80	80	80	80	80	80	80	80	80	80	80	80	80	80	80	00	30	-	-	-	0	0	0	
	最大ゲイン Maximum gain	MIN	OUTF1	E4	00	01	00	01 14	80	80	80	80	80	80	80	80	79	00	00	00	80	80	80	00	30	-	-	-	0	0	0	

BLOCK	項目 Item	信号入力点 Signal input point	測定点 Measurement point	I ² C BUS データ (I ² C BUS Data)																SW table									
				セレクトアドレス (Select Address)																									
				01(hex)	02(hex)	03(hex)	05(hex)	06(hex)	20(hex)	28(hex)	29(hex)	2A(hex)	2B(hex)	2C(hex)	30(hex)	41(hex)	44(hex)	47(hex)	51(hex)	54(hex)	57(hex)	75(hex)	90(hex)	F0(hex)	F1(hex)	FE(hex)	SW1	SW2	SW3
FADER / SUBWOOFER	最大ブーストゲイン Maximum boost gain	A1	OUTF1	E4	00	01	00	00	80	71	71	71	71	71	FF	00	00	00	80	80	80	00	30	-	-	-	0	0	0
	最大減衰量 Maximum attenuation	A1	OUTF1	E4	00	01	00	00	80	FF	FF	FF	FF	FF	FF	00	00	00	80	80	80	00	30	-	-	-	0	0	0
	ゲイン設定誤差 Gain set error	A1	OUTF1	E4	00	01	00	00	80	71	71	71	71	71	FF	00	00	00	80	80	80	00	30	-	-	-	0	0	0
	減衰量設定誤差 1 Attenuation set error 1	A1	OUTF1	E4	00	01	00	00	80	81	81	81	81	81	FF	00	00	00	80	80	80	00	30	-	-	-	0	0	0
	減衰量設定誤差 2 Attenuation set error 2	A1	OUTF1	E4	00	01	00	00	80	90	90	90	90	90	FF	00	00	00	80	80	80	00	30	-	-	-	0	0	0
	減衰量設定誤差 3 Attenuation set error 3	A1	OUTF1	E4	00	01	00	00	80	B0	B0	B0	B0	B0	FF	00	00	00	80	80	80	00	30	-	-	-	0	0	0
	出力インピーダンス Output impedance	OUTF1	OUTF1	E4	00	01	00	00	80	80	80	80	80	80	FF	00	00	00	80	80	80	00	30	-	-	-	0	2	1
最大出力電圧 Maximum output voltage	A1	OUTF1	E4	00	01	00	00	80	80	80	80	80	80	FF	00	00	00	80	80	80	00	30	-	-	-	0	0	0	
LOUDNESS	最大ゲイン Maximum gain	A1	OUTF1	E4	00	01	00	00	80	80	80	80	80	80	FF	00	00	00	80	80	80	14	30	-	-	-	0	0	0
	ゲイン設定誤差 Gain set error	A1	OUTF1	E4	00	01	00	00	80	80	80	80	80	80	FF	00	00	00	80	80	80	01 14	30	-	-	-	0	0	0
Level meter	最大ゲイン Maximum gain	A1 A2	LOUT	E4	00	01	00	00	80	80	80	80	80	80	FF	00	00	00	80	80	80	00	30	-	-	-	0	0	0
	ゲイン設定誤差 Gain set error	-	LOUT	E4	00	01	00	00	80	80	80	80	80	80	FF	00	00	00	80	80	80	00	30	-	-	-	0	0	0

I²C BUS 制御信号仕様(CONTROL SIGNAL SPECIFICATION)

(1)バス・ラインおよび I/O ステージの電氣的仕様およびタイミング

(Electrical specifications and timing for bus lines and I/O stages)

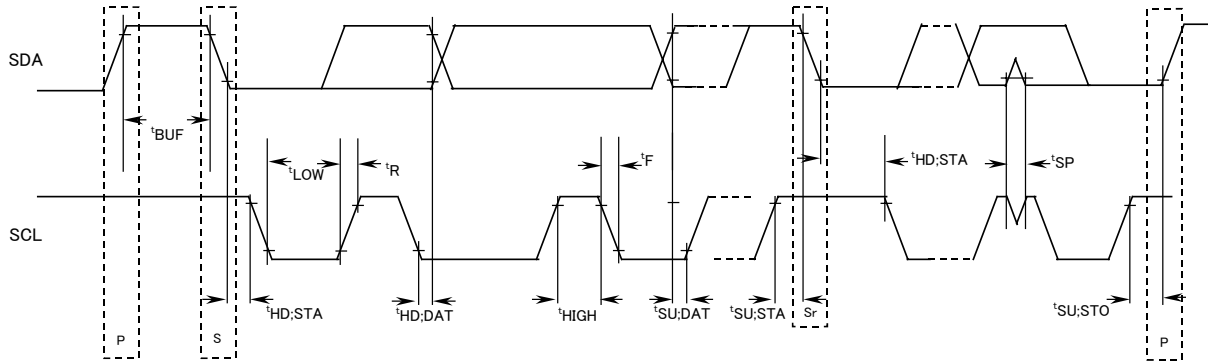

Fig.-4 I²C バス上のタイミング定義(Definition of timing on the I²C-bus)

表 1 I²C バスの SDA および SCL バス・ラインの特性

Table 1 Characteristics of the SDA and SCL bus lines for I²C-bus devices

パラメータ (Parameter)	記号 (Symbol)	高速モード I ² C バス (Fast-mode I ² C-bus)		単位 (Unit)
		Min.	Max.	
1 SCL クロック周波数 SCL clock frequency	fSCL	0	400	kHz
2 「停止」条件と「開始」条件の間のバス・フリー・タイム Bus free time between a STOP and START condition	tBUF	1.3	—	μS
3 ホールド・タイム(再送)「開始」条件。この期間の後、最初の クロック・パルスが生成されます。 Hold time (repeated) START condition. After this period, the first clock pulse is generated	tHD;STA	0.6	—	μS
4 SCL クロックの LOW 状態ホールド・タイム LOW period of the SCL clock	tLOW	1.3	—	μS
5 SCL クロックの HIGH 状態ホールド・タイム HIGH period of the SCL clock	tHIGH	0.6	—	μS
6 再送「開始」条件のセットアップ時間 Set-up time for a repeated START condition	tSU;STA	0.6	—	μS
7 データ・ホールド・タイム Data hold time:	tHD;DAT	0*	—	μS
8 データ・セットアップ時間 Data set-up time	tSU; DAT	100	—	ns
9 SDA および SCL 信号の立ち上がり時間 Rise time of both SDA and SCL signals	tR	20+Cb	300	ns
10 SDA および SCL 信号の立ち下がり時間 Fall time of both SDA and SCL signals	tF	20+Cb	300	ns
11 「停止」条件のセットアップ時間 Set-up time for STOP condition	tSU;STO	0.6	—	μS
12 各バス・ラインの容量性負荷 Capacitive load for each bus line	Cb	—	400	pF

上記の数値はすべて V_{IH min.} および V_{IL max.} レベルに対応した値です。(表 2 参照) All values referred to V_{IH min.} and V_{IL max.} Levels (see Table 2).

* 送信装置は SCL の立ち下がり端の未定義領域を越えるために、(SCL 信号の V_{IH min.} での) SDA 信号用に最低 300ns のホールド時間を内部的に提供する必要があります。

A device must internally provide a hold time of at least 300 ns for the SDA signal (referred to the V_{IH min.} of the SCL signal) in order to bridge the undefined region of the falling edge of SCL.

表 2 I²C バスの SDA および SCL I/O ステージの特性

Table 2 Characteristics of the SDA and SCL I/O stages for I²C-bus devices

パラメータ (Parameter)	記号 (Symbol)	高速モード (Fast-mode devices)		単位 (Unit)
		Min.	Max.	
13 LOW レベル入力電圧: LOW level input voltage: 入力レベルが一定の場合 fixed input levels	V _{IL}	-0.5	1	V
14 HIGH レベル入力電圧: HIGH level input voltage: 入力レベルが一定の場合 fixed input levels	V _{IH}	2.3	-	V
15 シュミット(Schmitt)トリガ入力のヒステリシス Hysteresis of Schmitt trigger inputs: 入力レベルが一定の場合 fixed input levels	V _{hys}	n/a	n/a	V
16 入力フィルタによって抑制されるスパイクのパルス幅 Pulse width of spikes which must be suppressed by the input filter.	t _{SP}	0	50	ns
17 LOW レベル出力電圧(オープン・ドレインまたはオープン・コレクタ): LOW level output voltage (open drain or open collector): シンク電流 3mA 時 at 3mA sink current	V _{OL1}	0	0.4	V
18 バスのキャパシタンスが 10pF~400pF の場合の V _{IHmin.} から V _{ILmax.} への出力立ち上がり時間: Output fall time from V _{IHmin.} to V _{ILmax.} with a bus capacitance from 10 pF to 400pF: V _{OL1} でのシンク電流 3mA 時 with up to 3mA sink current at V _{OL1}	t _{OF}	20+0.1C _b *1)	250 *2)	ns
19 入力電圧 0.4V~0.9V _{DDmax.} 時の各 I/O ピンの入力電流 Input current each I/O pin with an input voltage between 0.4V and 0.9 V _{DDmax.}	I _i	-10	10	μA
20 各 I/O ピンのキャパシタンス Capacitance for each I/O pin.	C _i	—	10	pF

n/a = 該当せず n/a = not applicable

1) 最大 V_{IH}=V_{DDmax}+0.5V, V_{DDMAX}=5.5V

maximum V_{IH}=V_{DDmax}+0.5V, V_{DDMAX}=5.5V

2) C_b=1 つのバス・ラインのキャパシタンス(単位 pF)。C_b = capacitance of one bus line in pF.

3) 表 1 で示されている SDA および SCL バス・ラインの最大 t_F(300ns)は出力段での最大 t_{OF}(250ns)より大きくなります。これによって、図 4 に示すように、最大規定 t_F を越えることなく SDA/SCL ピンと SDA/SCL バス・ラインの間に直列保護抵抗(R_s)を接続することが可能となります。

Note that the maximum t_F for the SDA and SCL bus lines quoted in Table 1 (300ns) is longer than the specified maximum t_{OF} for the output stages (250ns). This allows series protection resistors (R_s) to be connected between the SDA/SCL pins and the SDA/SCL bus lines as shown in Fig. 4 without exceeding the maximum specified t_F.

(2) I²C BUS フォーマット(I²C BUS FORMAT)

MSB	LSB	MSB	LSB	MSB	LSB		
S	Slave Address	A	Select Address	A	Data	A	P
1bit	8bit	1bit	8bit	1bit	8bit	1bit	1bit

- S = Start conditions (Recognition of start bit)
- Slave Address = Recognition of slave address. 7 bits in upper order are voluntary. The least significant bit is "L" due to writing.
- A = ACKNOWLEDGE bit (Recognition of acknowledgement)
- Select Address = Select every of volume, bass and treble.
- Data = Data on every volume and tone.
- P = Stop condition (Recognition of stop bit)

(3) I²C BUS インターフェース・プロトコル(I²C BUS Interface Protocol)

1) 基本形(Basic form)

S	Slave Address	A	Select Address	A	Data	A	P
MSB	LSB	MSB	LSB	MSB	LSB		

2) オートインクリメント(セレクトアドレスが、データ数だけインクリメント(+1)します。)

(Automatic increment (Select Address increases (+1) according to the number of data.)

S	Slave Address	A	Select Address	A	Data1	A	Data2	A	...	DataN	A	P
MSB	LSB	MSB	LSB	MSB	LSB	MSB	LSB	MSB	LSB	MSB	LSB	

- (例) ①データ 1 は、セレクトアドレスで指定したアドレスのデータとして設定します。
 ②データ 2 は、セレクトアドレス+1 で指定したアドレスのデータとして設定します。
 ③データ N は、セレクトアドレス+N-1 で指定したアドレスのデータとして設定します。

(Example) ① Data1 shall be set as data of address specified by Select Address.

② Data2 shall be set as data of address specified by Select Address +1.

③ DataN shall be set as data of address specified by Select Address +N-1.

3) 送信できない構成(この場合は、セレクトアドレス 1 のみ設定されます。)

(Configuration unavailable for transmission (In this case, only Select Address1 is set.)

S	Slave Address	A	Select Address1	A	Data	A	Select Address 2	A	Data	A	P
MSB	LSB	MSB	LSB	MSB	LSB	MSB	LSB	MSB	LSB	MSB	LSB

(注意) データの次にセレクトアドレス 2 としてデータを送信した場合、セレクトアドレス 2 として認識せず、データとして認識します。
 (Note) If any data is transmitted as Select Address 2 next to data, it is recognized as data, not as Select Address 2.

(4) スレーブアドレス (Slave address)

MSB							LSB	
A6	A5	A4	A3	A2	A1	A0	R/W	
1	0	0	0	0	0	0	0	80H

(5) セレクトアドレスとデータ(Select Address & Data)

Items	Select Address (hex)	Data							
		MSB		Data				LSB	
		D7	D6	D5	D4	D3	D2	D1	D0
Initial setup 1	01	Advanced switch ON/OFF	1	Advanced switch time of Input Gain/Volume Tone/Fader/Loudness/Mixing		0	1	Advanced switch time of Mute	
Initial setup 2	02	0	Level Meter RESET	Subwoofer Output Select		0	0	Subwoofer LPF fc	
Initial setup 3	03	0	0	0	Loudness fo		0	0	1
Input Selector	05	0	0	0	Input selector				
Input gain	06	Mute ON/OFF	0	0	Input Gain				
Volume gain	20	Volume Gain / Attenuation							
Fader 1ch Front	28	Fader Gain / Attenuation							
Fader 2ch Front	29	Fader Gain / Attenuation							
Fader 1ch Rear	2A	Fader Gain / Attenuation							
Fader 2ch Rear	2B	Fader Gain / Attenuation							
Fader Subwoofer	2C	Fader Gain / Attenuation							
Mixing	30	Mixing Gain / Attenuation							
Bass setup	41	0	0	Bass fo		0	0	Bass Q	
Middle setup	44	0	0	Middle fo		0	0	Middle Q	
Treble setup	47	0	0	Treble fo		0	0	0	Treble Q
Bass gain	51	Bass Boost/Cut	0	0	Bass Gain				
Middle gain	54	Middle Boost/Cut	0	0	Middle Gain				
Treble gain	57	Treble Boost/Cut	0	0	Treble Gain				
Loudness Gain	75	0	Loudness Hicut		Loudness Gain				
Initial setup 4	90	0	0	1	1	0	0	0	0
Test Mode	F0	0	0	0	0	0	0	0	0
	F1	0	0	0	0	0	0	0	0
System Reset	FE	1	0	0	0	0	0	0	1

 アドバンスド・スイッチ (Advanced switch)

注意(Note)

1. 網掛け部の機能切換え時において、アドバンスト・スイッチ動作を行います。
In function changing of the hatching part, it works Advanced switch..
2. 連続データ転送時は、オートインクリメント機能によりセレクトアドレスが下記のように巡回します。
Upon continuous data transfer, the Select Address is circulated by the automatic increment function, as shown below.

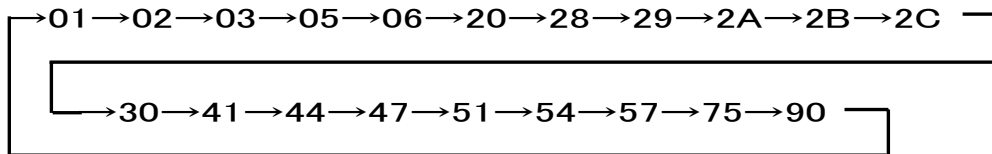

3. アドバンスト・スイッチなしの入力セクタ、サブウーハ出力選択などの機能は切換えノイズ対策をしておりません。従いまして、これらの設定変更時はセット側にて音声ミュートをかけるなどの対策をおこなってください。
For the function of input selector and subwoofer output select etc, it is not corresponded for advanced switch. Therefore, please apply mute on the side of a set when changes these setting.
4. 入力セクタ切換え時に本 IC のミュート機能をご使用になられる際には、アドバンスト・ミュート切換え時間を考慮してミュート ON/OFF を行って下さい。
When using mute function of this IC at the time of changing input selector, please switch mute ON/OFF for waiting advanced-mute time.

Select address 01 (hex)

Mode	MSB Advanced switch time of Mute							LSB	
	D7	D6	D5	D4	D3	D2	D1	D0	
0.6msec	Advanced Switch ON/OFF	1	Advanced switch time of Input gain/Volume Tone/Fader/Loudness		0	1	0	0	
1.0msec							0	1	
1.4msec							1	0	
3.2msec							1	1	

Mode	MSB 03 Advanced switch time of Input gain/Volume/Tone/Fader/Loudness							LSB	
	D7	D6	D5	D4	D3	D2	D1	D0	
4.7 msec	Advanced Switch ON/OFF	1	0	0	0	1	Advanced switch Time of Mute		
7.1 msec			0	1					
11.2 msec			1	0					
14.4 msec			1	1					

Mode	MSB Advanced switch ON/OFF							LSB	
	D7	D6	D5	D4	D3	D2	D1	D0	
OFF	0	1	Advanced switch time of Input gain/Volume Tone/Fader/Loudness		0	1	Advanced switch Time of Mute		
ON	1								

Select address 02(hex)

fc	MSB Subwoofer LPF fc							LSB	
	D7	D6	D5	D4	D3	D2	D1	D0	
OFF	0	Level Meter RESET	Subwoofer Output Select		0	0	0	0	
55Hz							0	1	
85Hz							1	0	
120Hz							1	1	

fc	MSB Subwoofer Output Select							LSB	
	D7	D6	D5	D4	D3	D2	D1	D0	
LPF	0	Level Meter RESET	0	0	0	0	Subwoofer LPF fc		
Front			0	1					
Rear			1	0					
禁止 (Prohibition)			1	1					

fc	MSB Level Meter RESET							LSB	
	D7	D6	D5	D4	D3	D2	D1	D0	
HOLD	0	0	Subwoofer output select		0	0	Subwoofer LPF fc		
RESET		1							

:Initial condition

Select address 03(hex)

Mode	Loudness fo							
	MSB							LSB
	D7	D6	D5	D4	D3	D2	D1	D0
250Hz	0	0	0	0	0	0	0	1
400Hz				0	1			
800Hz				1	0			
禁止 (Prohibition)				1	1			

Select address 05(hex)

Mode			Input Selector							
	OUT F1	OUT F2	MSB							LSB
			D7	D6	D5	D4	D3	D2	D1	D0
A	A1	A2	Full-diff bias type select	0	0	0	0	0	0	0
B	B1	B2					0	0	0	1
C	C1	C2					0	0	1	0
D single	DP1	DP2					0	0	1	1
E1 single	EP1	EN1					1	0	1	0
E2 single	EN2	EP2					1	0	1	1
D diff	DP1	DP2					0	1	1	0
E full diff	EP1	EP2					1	0	0	0
Input SHORT							1	0	0	1
禁止 (Prohibition)							Other setting			

Input SHORT: 各入力部の入力インピーダンスを 100kΩ (TYP) から 6kΩ (TYP) まで下げる。(カップリングコンデンサ急速充電用)

The input impedance of each input terminal is lowered from 100kΩ (TYP) to 6 kΩ (TYP).(For quick charge of coupling capacitor)

 :Initial condition

Select address 05(hex)

Mode	Full-diff Bias Type Select							LSB
	D7	D6	D5	D4	D3	D2	D1	D0
Negative Input	0	0	0	0	Input Selector			
Bias	1							

Negative input type

グラウンドアイソレーションアンプの形式でご使用される場合に選択して下さい。
(For Ground-isolation type.)

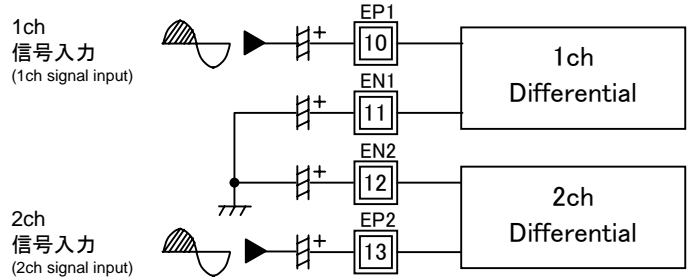

Bias type

差動アンプの形式でご使用される場合に選択して下さい。
(For differential amplifier type.)

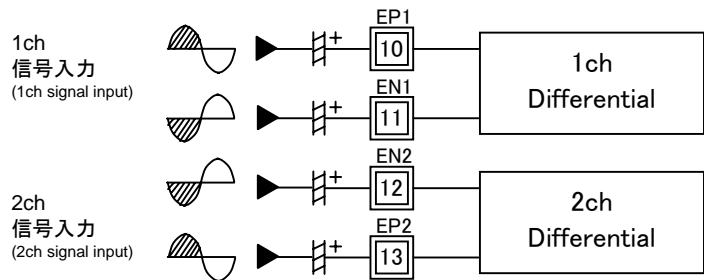

Select address 06 (hex)

Mode	Input Gain							LSB
	D7	D6	D5	D4	D3	D2	D1	D0
0dB	Mute ON/OFF	0	0	0	0	0	0	0
1dB				0	0	0	0	1
2dB				0	0	0	1	0
3dB				0	0	0	1	1
4dB				0	0	1	0	0
5dB				0	0	1	0	1
6dB				0	0	1	1	0
7dB				0	0	1	1	1
8dB				0	1	0	0	0
9dB				0	1	0	0	1
10dB				0	1	0	1	0
11dB				0	1	0	1	1
12dB				0	1	1	0	0
13dB				0	1	1	0	1
14dB				0	1	1	1	0
15dB				0	1	1	1	1
16dB				1	0	0	0	0
17dB				1	0	0	0	1
18dB				1	0	0	1	0
19dB				1	0	0	1	1
20dB	1	0	1	0	0			
禁止 (Prohibition)				1	1	0	1	1
				:	:	:	:	:
				1	1	1	1	1

Initial condition

CONFIDENTIAL

Select address 06 (hex)

Mode	Mute ON/OFF							LSB	
	D7	D6	D5	D4	D3	D2	D1	D0	
OFF	0	0	0	Input Gain					
ON	1								

Select address 20, 28, 29, 2A, 2B, 2C (hex)

Gain & ATT	Vol, Fader Gain / Attenuation							
	D7	D6	D5	D4	D3	D2	D1	D0
禁止 ※ (Prohibition)	0	0	0	0	0	0	0	0
	0	0	0	0	0	0	0	1
	:	:	:	:	:	:	:	:
	0	1	1	1	0	0	0	0
15dB	0	1	1	1	0	0	0	1
14dB	0	1	1	1	0	0	1	0
13dB	0	1	1	1	0	0	1	1
⋮	⋮	⋮	⋮	⋮	⋮	⋮	⋮	⋮
⋮	⋮	⋮	⋮	⋮	⋮	⋮	⋮	⋮
10dB	0	1	1	1	0	1	1	0
9dB	0	1	1	1	0	1	1	1
8dB	0	1	1	1	1	0	0	0
7dB	0	1	1	1	1	0	0	1
6dB	0	1	1	1	1	0	1	0
5dB	0	1	1	1	1	0	1	1
4dB	0	1	1	1	1	1	0	0
3dB	0	1	1	1	1	1	0	1
2dB	0	1	1	1	1	1	1	0
1dB	0	1	1	1	1	1	1	1
0dB	1	0	0	0	0	0	0	0
-1dB	1	0	0	0	0	0	0	1
-2dB	1	0	0	0	0	0	1	0
-3dB	1	0	0	0	0	0	1	1
⋮	⋮	⋮	⋮	⋮	⋮	⋮	⋮	⋮
-78dB	1	1	0	0	1	1	1	0
-79dB	1	1	0	0	1	1	1	1
禁止 ※ (Prohibition)	1	1	0	1	0	0	0	0
	:	:	:	:	:	:	:	:
	1	1	1	1	1	1	1	0
-∞dB	1	1	1	1	1	1	1	1

 :Initial condition

Select address 30(hex)

Gain & ATT	MSB Mixing Gain / Attenuation LSB							
	D7	D6	D5	D4	D3	D2	D1	D0
禁止 ※ (Prohibition)	0	0	0	0	0	0	0	0
	0	0	0	0	0	0	0	1
	:	:	:	:	:	:	:	:
	0	1	1	1	1	0	0	0
7dB	0	1	1	1	1	0	0	1
6dB	0	1	1	1	1	0	1	0
5dB	0	1	1	1	1	0	1	1
4dB	0	1	1	1	1	1	0	0
3dB	0	1	1	1	1	1	0	1
2dB	0	1	1	1	1	1	1	0
1dB	0	1	1	1	1	1	1	1
0dB	1	0	0	0	0	0	0	0
-1dB	1	0	0	0	0	0	0	1
-2dB	1	0	0	0	0	0	1	0
-3dB	1	0	0	0	0	0	1	1
⋮	⋮	⋮	⋮	⋮	⋮	⋮	⋮	⋮
-78dB	1	1	0	0	1	1	1	0
-79dB	1	1	0	0	1	1	1	1
禁止 ※ (Prohibition)	1	1	0	1	0	0	0	0
	:	:	:	:	:	:	:	:
	1	1	1	1	1	1	1	0
MIX OFF	1	1	1	1	1	1	1	1

 :Initial condition

Select address 41(hex)

Q factor	MSB		Bass Q factor				LSB	
	D7	D6	D5	D4	D3	D2	D1	D0
0.5	0	0	Bass fo		0	0	0	0
1.0							0	1
1.5							1	0
2.0							1	1

fo	MSB		Bass fo				LSB	
	D7	D6	D5	D4	D3	D2	D1	D0
60Hz	0	0	0	0	0	0	Bass Q factor	
80Hz			0	1				
100Hz			1	0				
120Hz			1	1				

Select address 44(hex)

Q factor	MSB		Middle Q factor				LSB	
	D7	D6	D5	D4	D3	D2	D1	D0
0.75	0	0	Middle fo		0	0	0	0
1.0							0	1
1.25							1	0
1.5							1	1

fo	MSB		Middle fo				LSB	
	D7	D6	D5	D4	D3	D2	D1	D0
500Hz	0	0	0	0	0	0	Middle Q factor	
1kHz			0	1				
1.5kHz			1	0				
2.5kHz			1	1				

Select address 47 (hex)

Q factor	MSB		Treble Q factor				LSB	
	D7	D6	D5	D4	D3	D2	D1	D0
0.75	0	0	Treble fo		0	0	0	0
1.25								1

fo	MSB		Treble fo				LSB	
	D7	D6	D5	D4	D3	D2	D1	D0
7.5k	0	0	0	0	0	0	0	Treble Q factor
10k			0	1				
12.5k			1	0				
15k			1	1				

 :Initial condition

Select address 51, 54, 57 (hex)

Gain	MSB Bass/Middle/Treble Gain LSB							
	D7	D6	D5	D4	D3	D2	D1	D0
0dB				0	0	0	0	0
1dB				0	0	0	0	1
2dB				0	0	0	1	0
3dB				0	0	0	1	1
4dB				0	0	1	0	0
5dB				0	0	1	0	1
6dB				0	0	1	1	0
7dB				0	0	1	1	1
8dB				0	1	0	0	0
9dB				0	1	0	0	1
10dB	Bass/ Middle/ Treble Boost /cut	0	0	0	1	0	1	0
11dB				0	1	0	1	1
12dB				0	1	1	0	0
13dB				0	1	1	0	1
14dB				0	1	1	1	0
15dB				0	1	1	1	1
16dB				1	0	0	0	0
17dB				1	0	0	0	1
18dB				1	0	0	1	0
19dB				1	0	0	1	1
20dB				1	0	1	0	0
禁止 ※ (Prohibition)				1	0	1	0	1
				:	:	:	:	:
				1	1	1	1	0
				1	1	1	1	1

Mode	MSB Bass/Middle/Treble Boost/Cut LSB							
	D7	D6	D5	D4	D3	D2	D1	D0
Boost	0	0	0	Bass/Middle/Treble Gain				
Cut	1							

:Initial condition

Select address 75 (hex)

Mode	Loudness Hicut							
	MSB	Loudness Hicut						LSB
	D7	D6	D5	D4	D3	D2	D1	D0
Hicut1	0	0	0	Loudness Gain				
Hicut2		0	1					
Hicut3		1	0					
Hicut4		1	1					

Gain	Loudness Gain							
	MSB	Loudness Gain						LSB
	D7	D6	D5	D4	D3	D2	D1	D0
0dB	0	Loudness Hicut		0	0	0	0	0
1dB				0	0	0	0	1
2dB				0	0	0	1	0
3dB				0	0	0	1	1
4dB				0	0	1	0	0
5dB				0	0	1	0	1
6dB				0	0	1	1	0
7dB				0	0	1	1	1
8dB				0	1	0	0	0
9dB				0	1	0	0	1
10dB				0	1	0	1	0
11dB				0	1	0	1	1
12dB				0	1	1	0	0
13dB				0	1	1	0	1
14dB				0	1	1	1	0
15dB				0	1	1	1	1
16dB				1	0	0	0	0
17dB				1	0	0	0	1
18dB				1	0	0	1	0
19dB				1	0	0	1	1
20dB	1	0	1	0	0			
禁止 ※ (Prohibition)				1	0	1	0	1
				:	:	:	:	:
				1	1	1	1	1

 :Initial condition

(6) 電源オン時の初期状態について(About power on reset)

電源 ON 時において IC 内部で初期化を行う回路を内蔵しております。しかし、セット設計におかれましては万が一の場合を考えて、電源 ON 時に必ず初期データとして全てのアドレスにデータを送信し、またこの初期データを送信するまでの間はミュートをかけることを推奨いたします。

At on of supply voltage circuit made initialization inside IC is built-in. Please send data to all address as initial data at supply voltage on. And please supply mute at set side until this initial data is sent.

Item	Symbol	Limit			Unit	Condition
		Min.	Typ.	Max.		
VCC 立上げ時間 Rise time of VCC	Trise	20	—	—	usec	VCC 0→3V の立上げ時の時間 VCC rise time from 0V to 3V
パワーオンリセット 解除時の VCC 電圧 VCC voltage of release power on reset	Vpor	—	4.1	—	V	

(7) 外部強制ミュート端子について(About external compulsory mute terminal)

MUTE 端子の設定により、入力ゲイン部後にて、外部より強制的にミュートをかけることが可能です。

Mute is possible forcibly than the outside after input again department, by the setting of the MUTE terminal .

Mute Voltage Condition	Mode
GND~1.0V	MUTE ON
2.3V~VCC	MUTE OFF

Mute 電圧は定義された条件内に設定して下さい。

Establish the voltage of MUTE in the condition to have been defined.

* ボリウム／フェダーボリウム減衰量(詳細版)
(Volume / Fader volume attenuation of the details)

(dB)	D7	D6	D5	D4	D3	D2	D1	D0	(dB)	D7	D6	D5	D4	D3	D2	D1	D0
+15	0	1	1	1	0	0	0	1	-33	1	0	1	0	0	0	0	1
+14	0	1	1	1	0	0	1	0	-34	1	0	1	0	0	0	1	0
+13	0	1	1	1	0	0	1	1	-35	1	0	1	0	0	0	1	1
+12	0	1	1	1	0	1	0	0	-36	1	0	1	0	0	1	0	0
+11	0	1	1	1	0	1	0	1	-37	1	0	1	0	0	1	0	1
+10	0	1	1	1	0	1	1	0	-38	1	0	1	0	0	1	1	0
+9	0	1	1	1	0	1	1	1	-39	1	0	1	0	0	1	1	1
+8	0	1	1	1	1	0	0	0	-40	1	0	1	0	1	0	0	0
+7	0	1	1	1	1	0	0	1	-41	1	0	1	0	1	0	0	1
+6	0	1	1	1	1	0	1	0	-42	1	0	1	0	1	0	1	0
+5	0	1	1	1	1	0	1	1	-43	1	0	1	0	1	0	1	1
+4	0	1	1	1	1	1	0	0	-44	1	0	1	0	1	1	0	0
+3	0	1	1	1	1	1	0	1	-45	1	0	1	0	1	1	0	1
+2	0	1	1	1	1	1	1	0	-46	1	0	1	0	1	1	1	0
+1	0	1	1	1	1	1	1	1	-47	1	0	1	0	1	1	1	1
0	1	0	0	0	0	0	0	0	-48	1	0	1	1	0	0	0	0
-1	1	0	0	0	0	0	0	1	-49	1	0	1	1	0	0	0	1
-2	1	0	0	0	0	0	1	0	-50	1	0	1	1	0	0	1	0
-3	1	0	0	0	0	0	1	1	-51	1	0	1	1	0	0	1	1
-4	1	0	0	0	0	1	0	0	-52	1	0	1	1	0	1	0	0
-5	1	0	0	0	0	1	0	1	-53	1	0	1	1	0	1	0	1
-6	1	0	0	0	0	1	1	0	-54	1	0	1	1	0	1	1	0
-7	1	0	0	0	0	1	1	1	-55	1	0	1	1	0	1	1	1
-8	1	0	0	0	1	0	0	0	-56	1	0	1	1	1	0	0	0
-9	1	0	0	0	1	0	0	1	-57	1	0	1	1	1	0	0	1
-10	1	0	0	0	1	0	1	0	-58	1	0	1	1	1	0	1	0
-11	1	0	0	0	1	0	1	1	-59	1	0	1	1	1	0	1	1
-12	1	0	0	0	1	1	0	0	-60	1	0	1	1	1	1	0	0
-13	1	0	0	0	1	1	0	1	-61	1	0	1	1	1	1	0	1
-14	1	0	0	0	1	1	1	0	-62	1	0	1	1	1	1	1	0
-15	1	0	0	0	1	1	1	1	-63	1	0	1	1	1	1	1	1
-16	1	0	0	1	0	0	0	0	-64	1	1	0	0	0	0	0	0
-17	1	0	0	1	0	0	0	1	-65	1	1	0	0	0	0	0	1
-18	1	0	0	1	0	0	1	0	-66	1	1	0	0	0	0	1	0
-19	1	0	0	1	0	0	1	1	-67	1	1	0	0	0	0	1	1
-20	1	0	0	1	0	1	0	0	-68	1	1	0	0	0	1	0	0
-21	1	0	0	1	0	1	0	1	-69	1	1	0	0	0	1	0	1
-22	1	0	0	1	0	1	1	0	-70	1	1	0	0	0	1	1	0
-23	1	0	0	1	0	1	1	1	-71	1	1	0	0	0	1	1	1
-24	1	0	0	1	1	0	0	0	-72	1	1	0	0	1	0	0	0
-25	1	0	0	1	1	0	0	1	-73	1	1	0	0	1	0	0	1
-26	1	0	0	1	1	0	1	0	-74	1	1	0	0	1	0	1	0
-27	1	0	0	1	1	0	1	1	-75	1	1	0	0	1	0	1	1
-28	1	0	0	1	1	1	0	0	-76	1	1	0	0	1	1	0	0
-29	1	0	0	1	1	1	0	1	-77	1	1	0	0	1	1	0	1
-30	1	0	0	1	1	1	1	0	-78	1	1	0	0	1	1	1	0
-31	1	0	0	1	1	1	1	1	-79	1	1	0	0	1	1	1	1
-32	1	0	1	0	0	0	0	0	-∞	1	1	1	1	1	1	1	1

 :Initial condition

レベルメータについて (About Level meter)

(1) 制御データ(I²C BUS 制御信号) (Control Data (I²C BUS control signal))

- ①レベルメータ出力をリセットする時 → Select address 02(hex) D6 = "1" を送信して下さい。
When reset output of level meter... → Send D6 = " 1 " of select address 02(hex).
- ②レベルメータ出力リセットを解除する時(ホールド動作) → Select address 02(hex) D6 = "0" を送信して下さい。
When cancel of output reset of level meter (HOLD)... → Send D6 = " 0 " of select address 02(hex).

(2) 時間規定 (Time Regulations)

HOLD データ送信後、ピークホールド動作を開始します。検出する周波数帯域により、HOLD データ送信後の WAIT 時間を設定して下さい。WAIT 時間は検出する周波数帯域の1周期以上に設定して下さい。

例) 検出する周波数帯域を 40Hz 以上とした場合、『40Hz = 25ms = WAIT 時間』

なお、RESET データを送信したら必ず次に HOLD データも送信し、リセット解除 (HOLD 動作スタート) を行って下さい。

Peak hold operation will start after HOLD data is transmitted. Set the WAIT time after HOLD data transmission according to the frequency bandwidth detected.

WAIT time must be set to a minimum of one cycle over the detected frequency bandwidth.

Ex) Detected frequency bandwidth is above 40Hz, 『40Hz = 25ms = WAIT time』

After sending "reset data", send also "hold data" for canceling reset.

送信例 (Transmission Example)

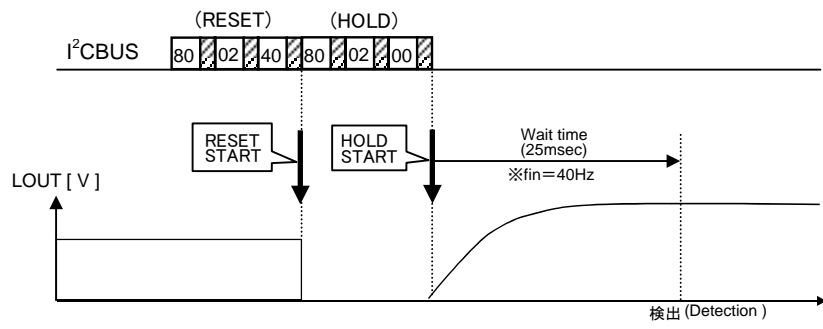

(3) レベルメータの入出力特性(参考図) (Input-output characteristic of level meter, reference)

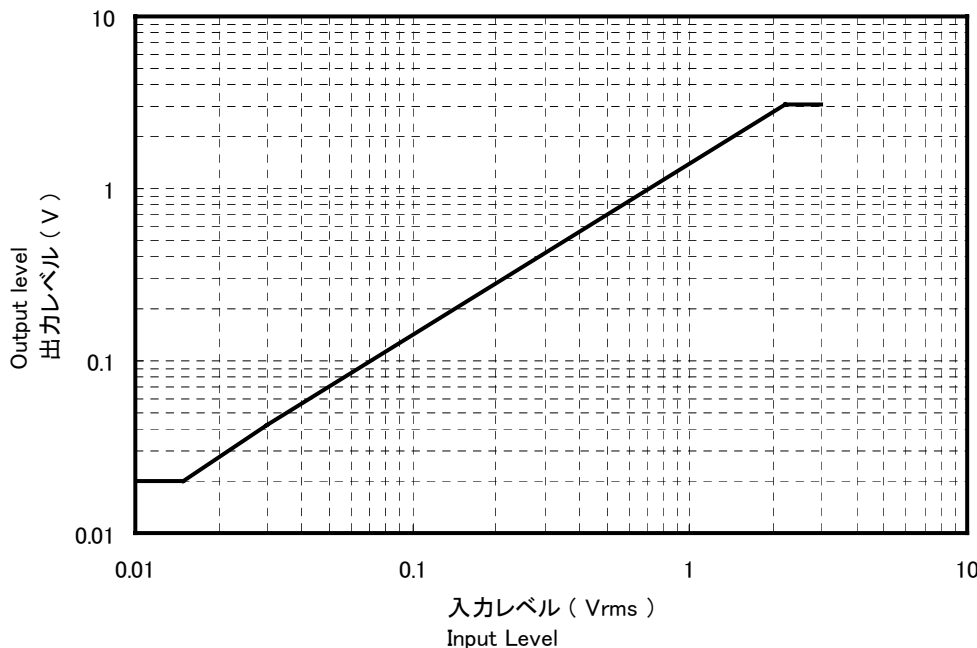

端子等価回路および説明 (Terminal Equivalent Circuit and Description)

端子番号 Terminal No.	端子名 Terminal Name	端子電圧 Terminal Voltage	等価回路 Equivalent Circuit	端子説明 Terminal Description
1 2 3 4 5 6	A1 A2 B1 B2 C1 C2	4.25		<p>音声入力端子。入力インピーダンスは 100kΩ (typ) です。</p> <p>A terminal for signal input. The input impedance is 100kΩ (typ).</p>
7 8 9 10 11 12 13	DP1 DN DP2 EP1 EN1 EN2 EP2	4.25		<p>シングル/差動切換可能な入力端子。入力インピーダンスは 250kΩ (typ) です。</p> <p>Input terminal available to Single/Differential mode. The input impedance is 250kΩ (typ).</p>
15	MUTE	-		<p>外部強制ミュート端子。端子電圧が LOW 時は on、Hi 時は off に設定されます。</p> <p>A terminal for external compulsory mute. If terminal voltage is High level, the mute is off. And if the terminal voltage is Low level, the mute is on.</p>
18 19 20 21 22 23	OUTS2 OUTS1 OUTR2 OUTR1 OUTF2 OUTF1	4.25		<p>フェダーとサブウーハの出力端子</p> <p>A terminal for fader and Subwoofer output.</p>

* 端子説明、入出力等価回路図中の数値は参考値であり、その保証をするものではありません。
The figure in the pin explanation and input/output equivalent circuit is reference value, it doesn't guarantee the value.

端子番号 Terminal No.	端子名 Terminal Name	端子電圧 Terminal Voltage	等価回路 Equivalent Circuit	端子説明 Terminal Description
24	VCC	8.5		電源端子 Power supply terminal.
17	LOUT	0~3.3		レベルメーター出力端子。 出力インピーダンスは 10kΩ (typ) です。 A terminal for level meter output. Output impedance is 10kΩ (typ).
25	SCL	—		I ² C BUS 通信のクロック入力端子 A terminal for clock input of I ² C BUS communication.
26	SDA	—		I ² C BUS 通信のデータ入力端子 A terminal for data input of I ² C BUS communication.
27	GND	0		グラウンド端子 Ground terminal.
28	FIL	4.25		VCC/2 端子 アナログ信号系の基準バイアス電圧です。外付けコンデンサ用の簡易プリチャージ、ディスチャージ回路内蔵。 1/2 VCC terminal. Voltage for reference bias of analog signal system. The simple precharge circuit and simple discharge circuit for an external capacitor are built in.

端子番号 Terminal No.	端子名 Terminal Name	端子電圧 Terminal Voltage	等価回路 Equivalent Circuit	端子説明 Terminal Description
16	LRST	-		<p>レベルメーターリセット端子。端子電圧が LOW 時は RESET OFF、Hi 時は RESET ON に設定されます。</p> <p>A terminal for Level meter reset. If terminal voltage is High level, the reset is on. And if the terminal voltage is Low level, the reset is off.</p>
14	MIN	4.25		<p>信号入力端子。入力インピーダンスは 27kΩ (typ) です。</p> <p>A terminal for signal input. The input impedance is 27kΩ (typ).</p>

* 端子説明、入出力等価回路図中の数値は参考値であり、その保証をするものではありません。
The figure in the pin explanation and input/output equivalent circuit is reference value, it doesn't guarantee the value.

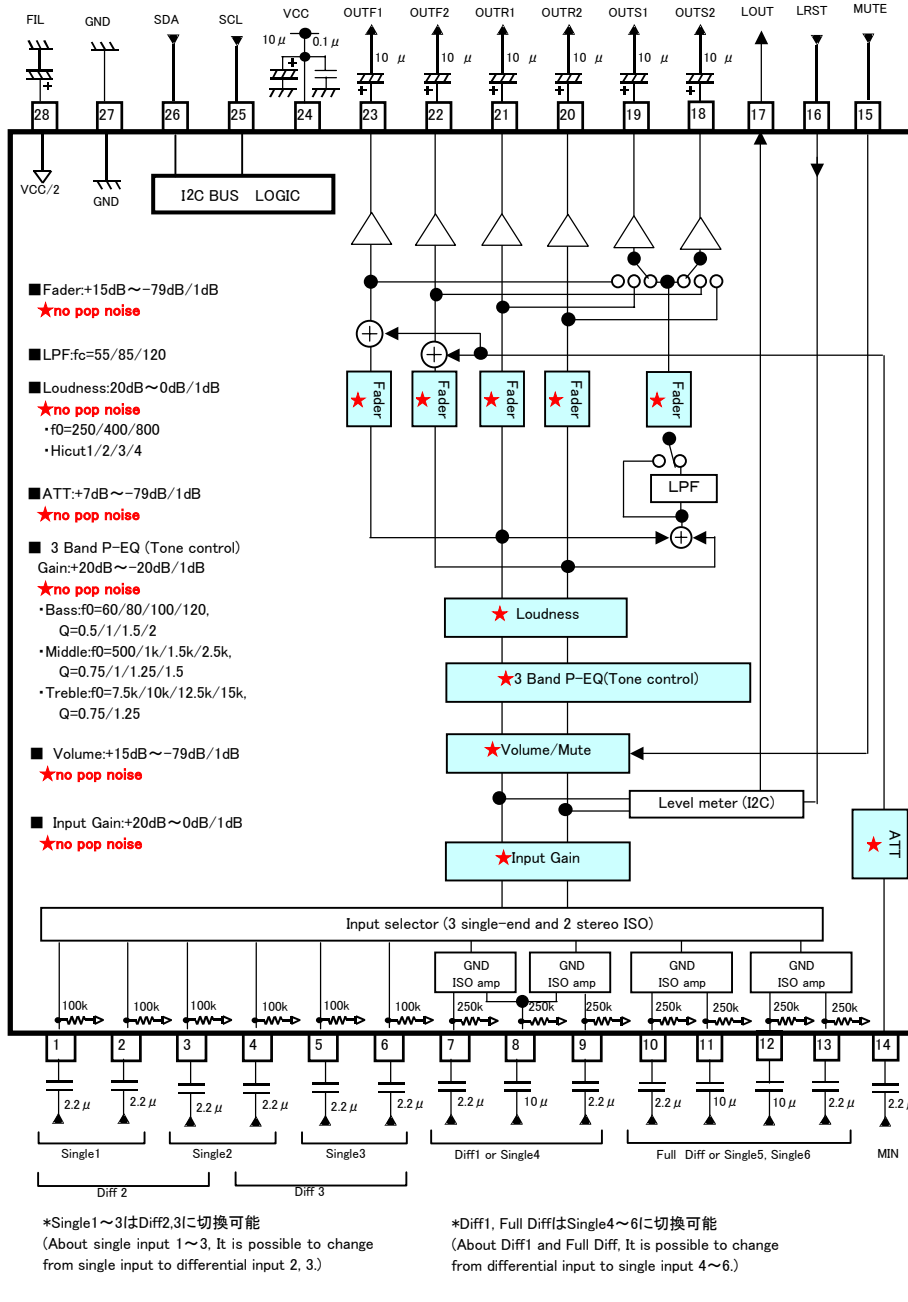

Fig.5 応用回路例(Application Circuit Diagram)

- 配線上の注意 Notes on wiring**
- ① 電源のデカップリングコンデンサは、GND に対して、出来るだけ最短距離で接続してください。
Please connect the decoupling capacitor of a power supply in the shortest distance as much as possible to GND.
 - ② GND ラインは一点接続して下さい。
Lines of GND shall be one-point connected.
 - ③ Digital の配線パターンはアナログ部の配線パターンから離して、クロストークのないようにして下さい。
Wiring pattern of Digital shall be away from that of analog unit and cross-talk shall not be acceptable.
 - ④ I²C BUS 部の SCL, SDA ラインはなるべく平行に引かないで下さい。隣接する時はシールドするようにして下さい。
Lines of SCL and SDA of I²C BUS shall not be parallel if possible. The lines shall be shielded, if they are adjacent to each other.
 - ⑤ アナログ入力信号ラインはなるべく平行に引かないで下さい。隣接する時はシールドするようにして下さい。
Lines of analog input shall not be parallel if possible. The lines shall be shielded, if they are adjacent to each other.

使用上の注意

CONFIDENTIAL

* 絶対最大定格電圧

絶対最大定格電圧を越えて VCC に電圧を印加した場合は回路電流が急増し、デバイスの特性劣化や破壊に至る場合があります。特にセットのサージ試験などで VCC 端子(24pin)にサージ印加が予想される場合、動作電圧+サージパルス成分を含めても絶対最大定格電圧を大きく超えて(14V 程度)電圧が印加されることがないようにご注意ください。

When it impressed the voltage on VCC more than the absolute maximum rating voltage, circuit currents increase rapidly, and there is absolutely a case to reach characteristic deterioration and destruction of a device. In particular in a surge examination of a set, when it is expected the impressing surge at VCC terminal(24pin), please do not impress the large and over the absolute maximum rating voltage (including a operating voltage + surge ingredient (around 14V)).

2.信号入力について(About a signal input part)

* 入力カップリングコンデンサの定数設定について
(About constant set up of input coupling capacitor)

信号入力端子において、入力カップリングコンデンサ C[F]の定数設定は、IC 内部の入力インピーダンス R_{IN}[Ω]を十分に考慮して決定してください。RC の1次 HPF 特性を構成することになります。

In the signal input terminal, the constant setting of input coupling capacitor C(F) be sufficient input impedance R_{IN}(Ω) inside IC and please decide. The first HPF characteristic of RC is composed.

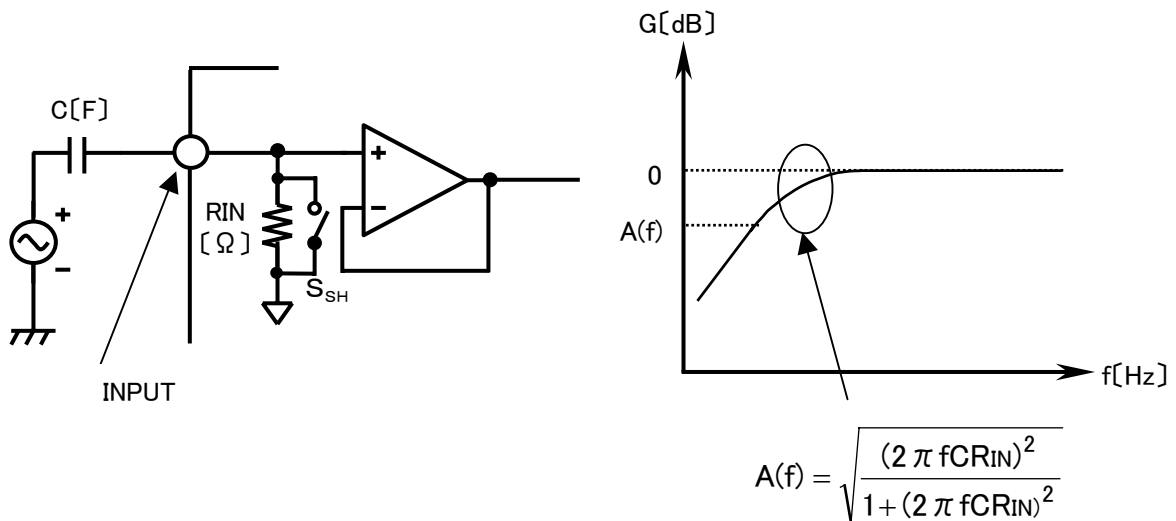

2) 入力セクタの SHORT について(About the input selector SHORT)

SHORT モードは入力セクタ部の全ての端子の入力インピーダンス R_{IN} をスイッチ S_{SH}=ON にして抵抗を小さくする命令です。SHORT 命令を選択しない時は、スイッチ S_{SH} は OFF です。

この命令により、外付けのカップリングコンデンサ C のチャージをはやめることが可能です。

SHORT モードは、S_{SH} のスイッチを ON にしてローインピーダンスにしますので、無信号時にご使用下さい。

SHORT mode is the command which makes switch S_{SH}=ON an input selector part and input impedance R_{IN} of all terminals, and makes resistance small. Switch S_{SH} is OFF when not choosing a SHORT command.

A constant time becomes small at the time of this command twisting to the resistance inside the capacitor connected outside and LSI. The charge time of a capacitor becomes short.

Since SHORT mode turns ON the switch of S_{SH} and makes it low impedance, please use it at the time of a non-signal.

* 出力負荷特性について (About output load characteristics)
出力の負荷特性は、下図の通りです(参考図)。負荷は 10[kΩ](TYP.)以上でご使用下さい。
The usage of load for output are below (reference). Please use the load more than 10[kΩ](TYP).

対象となる出力端子

端子 No.	端子名	端子 No.	端子名	端子 No.	端子名
23	OUTF1	21	OUTR1	19	OUTS1
22	OUTF2	20	OUTR2	18	OUTS2

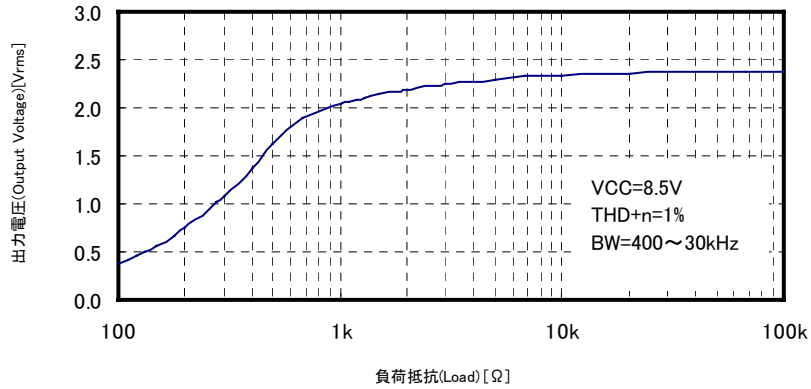

出力負荷特性 Vcc=8.5V 時(参考図) (Output load characteristic at Vcc=8.5V. (Reference))

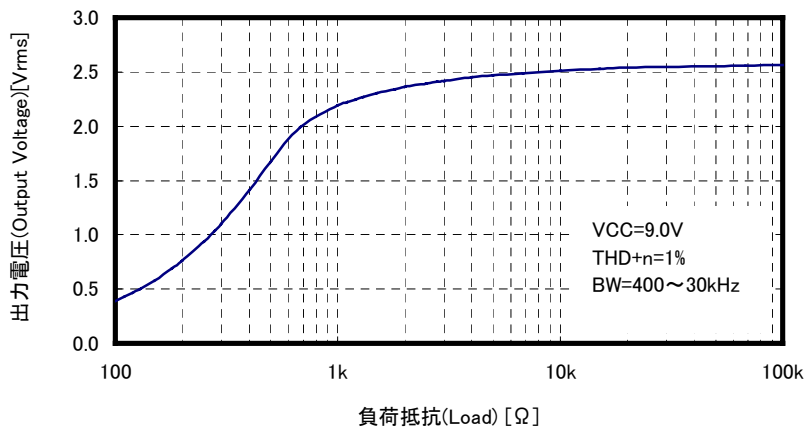

出力負荷特性 Vcc=9.0V(参考図) (Output load characteristic at Vcc=9.0V. (Reference))

* 電源 OFF 時の MUTE 端子(15pin)について
(About Mute terminal(15pin) when power supply is off)

電源が OFF 状態で MUTE 端子(15pin)に電圧を印加しないで下さい。
万が一、電圧印加してしまった場合に備えて 2.2kΩ 程度の電流制限抵抗を(MUTE 端子に直列に)挿入する事を推奨いたします(応用回路例を参照下さい)。

Any voltage shall not be supplied to Mute terminal (15pin) when power-supply is off.
Please insert a resistor (about 2.2kΩ) to Mute terminal in series, if voltage is supplied to mute terminal in case. (Please refer Application Circuit Diagram.)

X-ON Electronics

Largest Supplier of Electrical and Electronic Components

Click to view similar products for [Audio DSPs](#) category:

Click to view products by [ROHM](#) manufacturer:

Other Similar products are found below :

[E-TDA7377A](#) [TDA7716N](#) [BR281W31A101V1G](#) [LC823425-12G1-LR-H](#) [TDA7419N](#) [R3910-CFAB-E1B](#) [HMC474MP86ETR](#)
[AMIS30660CANH6G](#) [B300W35A102XYG](#) [MAX9892ERT+T](#) [MAX9892ELTT](#) [SB3229-E1](#) [NJW1157BFC2](#) [ZL38060LDG1](#) [SB3231-E1](#)
[HMC1022-SX](#) [SA3229-E1-T](#) [LC75056PE-H](#) [TDA7729](#) [NJW1195AV](#) [WM5102ECS/R](#) [CI1103](#) [WM5102ECS/R](#) [100-CG1820](#) [CS48L10-](#)
[CNZ](#) [CS48L10-CNZR](#) [CS47024C-CQZ](#) [CS48L10-CWZR](#) [CS48L11-CNZ](#) [HMC618LP3ETR](#) [HMC604LP3ETR](#) [HMC5622LS7TR](#)
[HMC288MS8ETR](#) [HMC240A](#) [STA323W13TR](#) [BU9408KS2](#) [DSPB56725AF](#) [TAS3204PAGR](#) [ADAU1467WBCPZ300](#)
[ADAU1463WBCPZ300](#) [BD37514FS-E2](#) [ADAU1463WBCPZ150](#) [ADAU1466WBCPZ300](#) [NJM2294V-TE1](#) [LC823450TA-2H](#) [NJM2537V-](#)
[TE1](#) [TWL1103TPBSQ1](#) [LC823450XDTBG](#) [HMC-AUH312-SX](#) [ADAV4622BSTZ](#)