

Sound Processors for Home Theater Systems

6ch / 9ch Stereo Input Selectors

BD3843FS, BD3841FS

No.10081EAT07

●Description

BD3843FS is a function switch IC with two 6ch (9ch for BD3841FS) inputs. It can independently control outputs of 2 systems: 2ch REC output (3ch for BD3841FS) and 1ch line output. Therefore, it can be used for 2nd room entertainment and 2nd source recording. BD3843FS has excellent cross-talk characteristics between channels and selectors. Low distortion, and low noise are realized by a basic pattern layout.

●Features

- 1) 2 room entertainment / 2 source recording.
- 2) 6ch volume LSI BD3813KS/BD3815KS can be controlled simultaneously by the serial control bus.
- 3) 7ch volume LSI BD3816K1, BD3817KS with BD3843FS can be controlled simultaneously by the serial control bus.
- 4) 14ch input is available by combining 2chips (BD3843FS and BD3841FS).
- 5) Excellent cross-talk characteristics between channels by basic pattern layout.
- 6) Built-in buffer amplifier.
- 7) 2-line serial control bus (for both 3.3V and 5V).
- 8) Operated by single and dual power sources.

●Applications

AV receivers, home theater systems, mini-audio systems, and TVs.

●Product lineup

Parameter	BD3843FS	BD3841FS
Input selector	6	9
REC output	2	3
Package	SSOP-A24	SSOP-A32

●Absolute maximum ratings (Ta=25°C)

Parameter	Symbol	Ratings	Unit
Power Supply Voltage	VCC	7.5 *1	V
	VEE	-7.5	
Input signal voltage	VIN	VCC+0.3~VEE-0.3	V
Power Dissipation	Pd	800 (BD3843FS) 950 (BD3841FS)	*2 mW
Operating temperature	Topr	-20~+75	°C
Storage temperature	Tastg	-55~+125	°C

*1 Even in the specified range of Power Supply Voltage, applying voltage only to the VCC side may cause an excessive current may cause permanent damage to the IC.

When starting up power supplies, VEE and VCC should be powered on simultaneously, or VEE first followed by VCC.

*2 Reduced by 8 mW/°C over 25°C (BD3843FS), when installed on the standard board (size: 70 x 70 x 1.6mm).
Reduced by 7.7 mW/°C over 25°C (BD3841FS), when installed on the standard board (size: 70 x 70 x 1.6mm).

● Operating range

Must function normally at $T_a = 25^\circ\text{C}$,

Part No.	Parameter	Symbol	Ratings			Unit
			Min.	Typ.	Max.	
BD3843FS	Action power source voltage (both power sources)	VCC	4	7	7.3	V
		VEE	-7.3	-7	-4	
	Action power source voltage (single power source)	VCC- VEE	8	14	14.6	
BD3841FS	Action power source voltage (both power sources)	VCC	5	7	7.3	V
		VEE	-7.3	-7	-5	
	Action power source voltage (single power source)	VCC- VEE	10	14	14.6	

● Electrical characteristics

$T_a=25^\circ\text{C}$, $V_{CC}=7\text{V}$, $V_{EE}=7\text{V}$, $f=1\text{kHz}$, $V_{in}=1\text{V}_{rms}$, $R_L=10\text{k}\Omega$, $R_g=600\Omega$, unless otherwise noted.

	Parameter		Symbol	Limits			Unit	Conditions
				Min.	Typ.	Max.		
	Circuit current	VCC	IQ	—	3	10	mA	No signal
		VEE		-10	-3	—		
Output	Output voltage gain 1ch		Gv1	-2	0	2	dB	
	Output voltage gain 2ch		Gv2	-2	0	2	dB	
	Total harmonic distortion ratio 1ch		THD1	—	0.004	0.05	%	BW=400~30kHz
	Total harmonic distortion ratio 2ch		THD2	—	0.004	0.05	%	BW=400~30kHz
	Maximum output voltage 1ch		Vomax1	3.4	4.2	—	Vrms	THD=1%
	Maximum output voltage 2ch		Vomax2	3.4	4.2	—	Vrms	THD=1%
	Output noise voltage 1ch		Vno1	—	1	5	μV_{rms}	$R_g=0\Omega$, BW=IHF-A
	Output noise voltage 2ch		Vno2	—	1	5	μV_{rms}	$R_g=0\Omega$, BW=IHF-A
	Cross-talk between channels 1ch→2ch		CTC12	—	-95	-80	dB	$R_g=0\Omega$, BW=IHF-A
	Cross-talk between channels 2ch→1ch		CTC21	—	-95	-80	dB	$R_g=0\Omega$, BW=IHF-A
	Cross-talk between selectors 1ch		CTS1	—	-95	-80	dB	$R_g=0\Omega$, BW=IHF-A
Cross-talk between selectors 2ch		CTS2	—	-95	-80	dB	$R_g=0\Omega$, BW=IHF-A	
REC output	R voltage gain 1ch		GVR1	-2	0	2	dB	$R_L=47\text{k}\Omega$,
	R voltage gain 2ch		GVR2	-2	0	2	dB	$R_L=47\text{k}\Omega$,
	R Total harmonic distortion ratio 1ch		THDR1	—	0.01	0.09	%	$R_L=47\text{k}\Omega$, BW=400~30kHz
	R Total harmonic distortion ratio 2ch		THDR2	—	0.01	0.09	%	$R_L=47\text{k}\Omega$, BW=400~30kHz
	R output noise voltage 1ch		VnoR1	—	1	5	μV_{rms}	$R_g=0\Omega$, BW=IHF-A
	R output noise voltage 2ch		VnoR2	—	1	5	μV_{rms}	$R_g=0\Omega$, BW=IHF-A
	R output impedance 1ch		RoutR1	—	50	100	Ω	
	R output impedance 2ch		RoutR2	—	50	100	Ω	

* Note: This IC is not designed to be radiation-resistant.

●Timing chart

1. Signal timing standards

- Data is read at the rise of clock.
- Latch is read at the fall of clock.
- End latch signal at LOW.
- * To avoid malfunctions, clock and data signals must terminate with the LOW state.

1byte=17bit

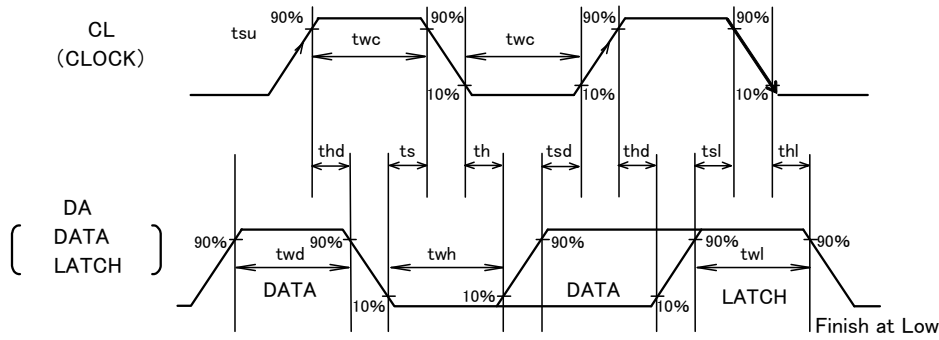

Fig.1

Parameter	Symbol	Limit			Unit
		Min.	Typ.	Max.	
Minimum clock width	twc	2.0	—	—	μs
Minimum data width	twd	2.0	—	—	μs
Minimum latch width	twl	2.0	—	—	μs
LOW hold width	twh	2.0	—	—	μs
Data setup time (DATA→CLK)	tsd	1.0	—	—	μs
Data hold time (CLK→DATA)	thd	1.0	—	—	μs
Latch setup time (CLK→LATCH)	tsl	1.0	—	—	μs
Latch hold time (DATA→LATCH)	thl	1.0	—	—	μs
Latch low setup time	ts	1.0	—	—	μs
Latch low hold time	th	1.0	—	—	μs

2. Voltage standards of control signal

Parameter	Conditions	Limits			Unit
		Min.	Typ.	Max.(≤Vcc)	
“H” input voltage	Vcc=5~7.3V VEE=-5~-7.3V	2.2	—	5.5	V
“L” input voltage		0	—	1.0	V

3. Control data format list

(1) BD3843FS control data format

← Data input direction

	MSB																LSB
	D16	D15	D14	D13	D12	D11	D10	D9	D8	D7	D6	D5	D4	D3	D2	D1	D0
Data	INPUT FUNCTION 1				INPUT FUNCTION 2				RECA 0:OFF 1:ON	RECB 0:OFF 1:ON	*	0	0	0	Select Address		

(2) BD3841FS control data format

← Data input direction

	MSB																LSB
	D16	D15	D14	D13	D12	D11	D10	D9	D8	D7	D6	D5	D4	D3	D2	D1	D0
Data	INPUT FUNCTION 1				INPUT FUNCTION 2				RECA 0:OFF 1:ON	RECB 0:OFF 1:ON	RECC 0:OFF 1:ON	*	*	*	1	0	1

*:Don't care.

(Ex.)

← Data input direction

MSB	LSB
Data	L

"L" represents latch.

●Block diagram, application circuit

1)BD3843FS)
(both power sources)

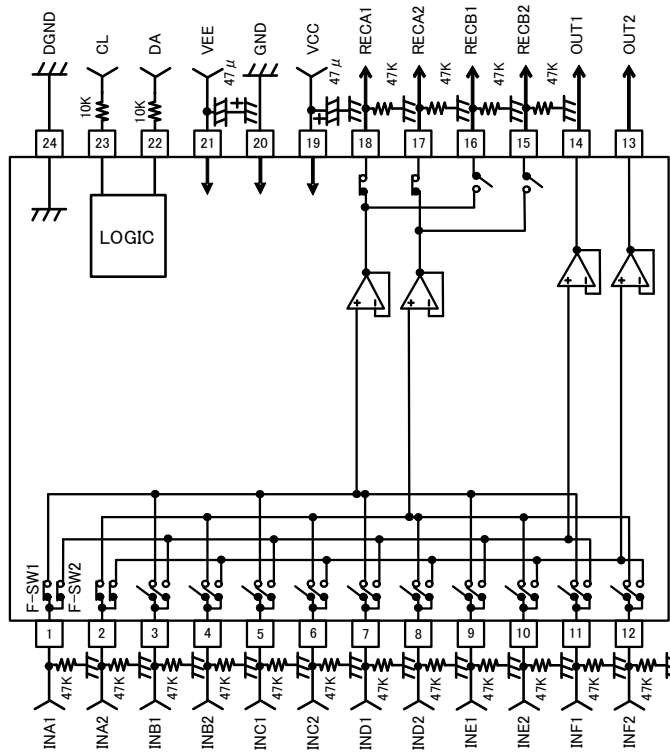

Fig.2

2)BD3841FS
(both power sources)

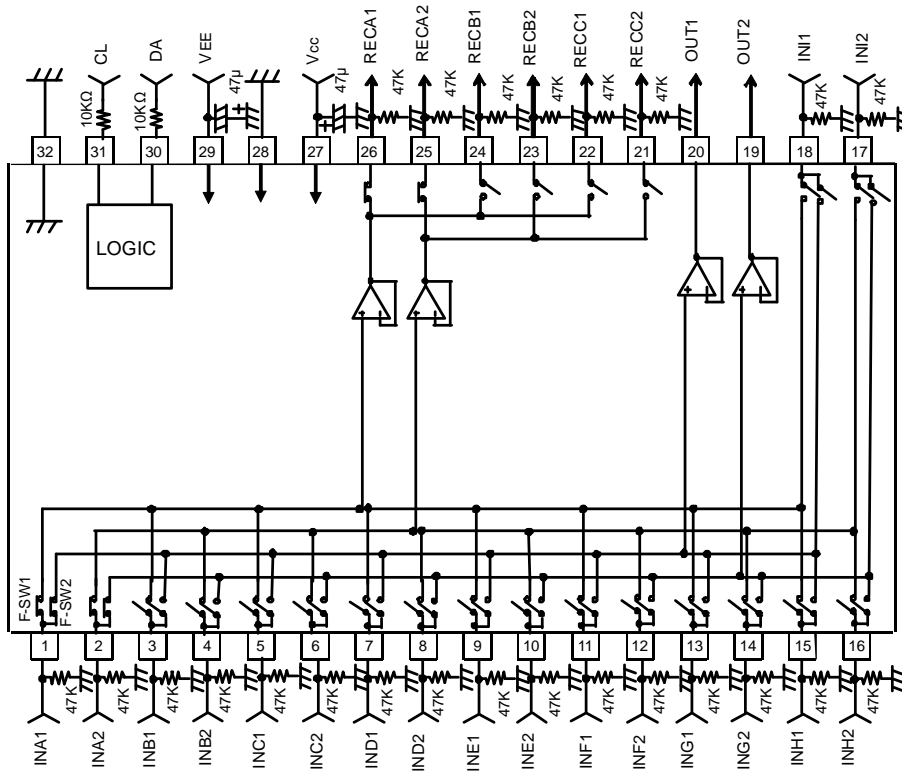

Fig.3

UNIT
RESISTANCE : Ω
CAPACITOR : F
* F-SW1 : INPUT FUNCTION1
F-SW2 : INPUT FUNCTION2

3) BD3843FS
(single power source)

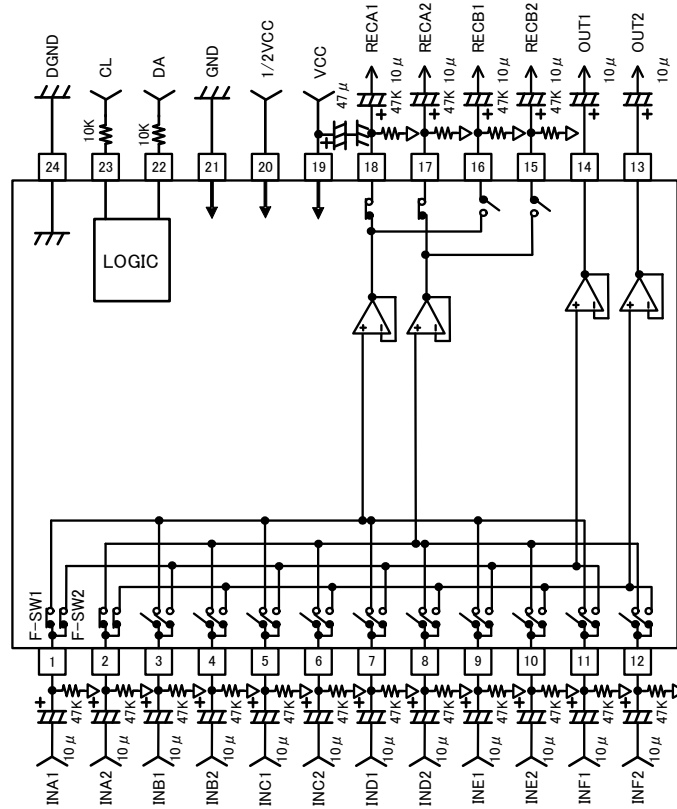

Fig.4

4) BD3841FS
(single power source)

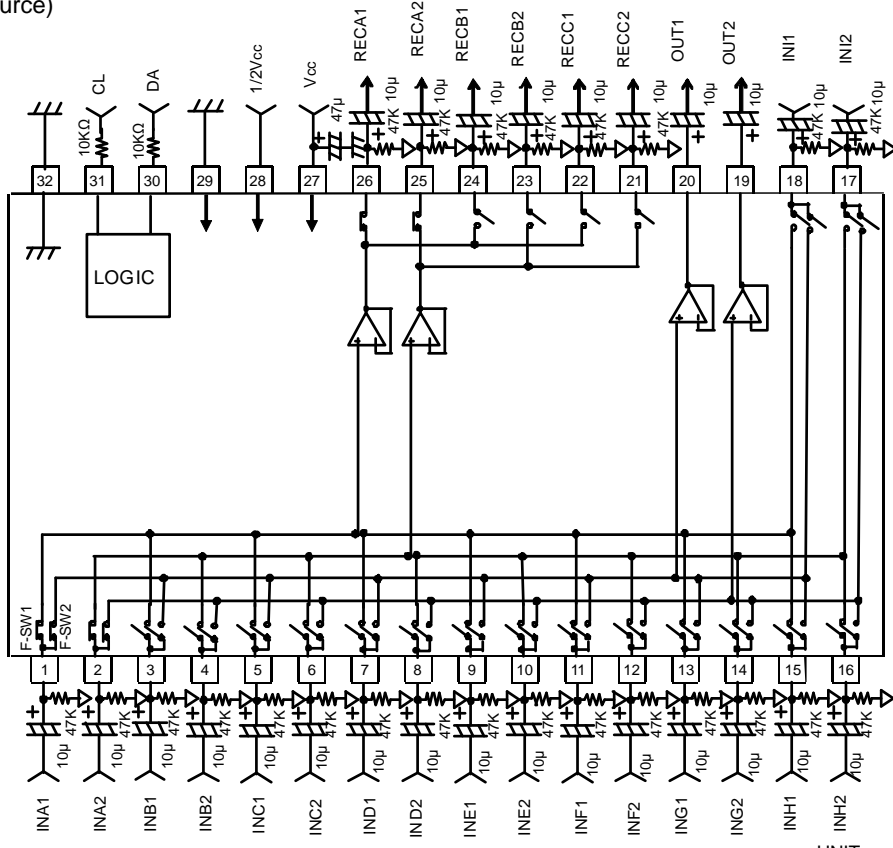

Fig.5

* F-SW1 : INPUT FUNCTION1
F-SW2 : INPUT FUNCTION2

UNIT
RESISTANCE : Ω
CAPACITOR : F
RESISTANCE : Ω

● Reference data

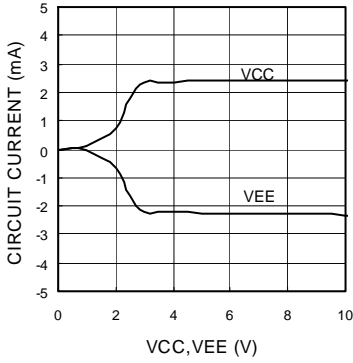

Fig.6 Circuit Current - Supply Voltage

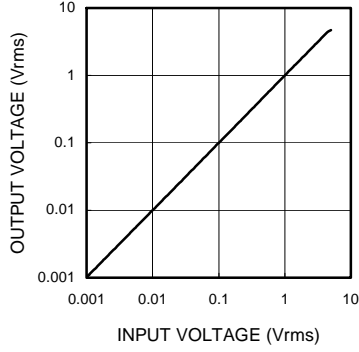

Fig.7 Output Voltage - Input Voltage

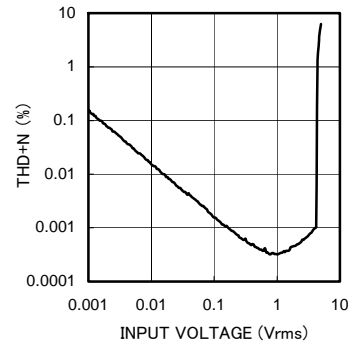

Fig.8 Total Harmonic Distortion - Input Voltage

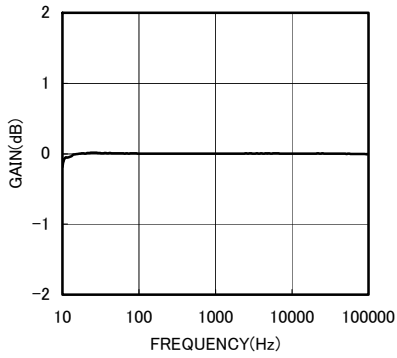

Fig.9 Voltage Gain - Frequency

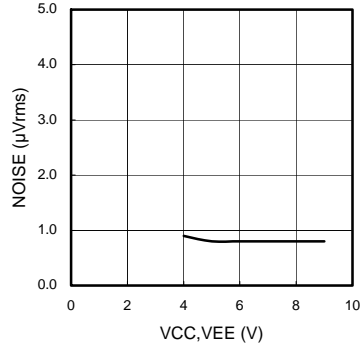

Fig.10 Output Noise Voltage - Supply Voltage

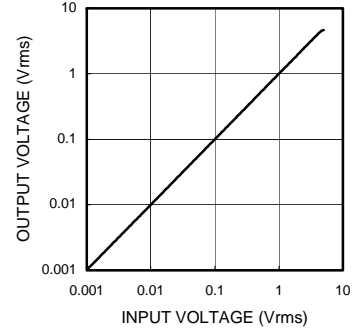

Fig.11 REC Output Voltage - Input Voltage

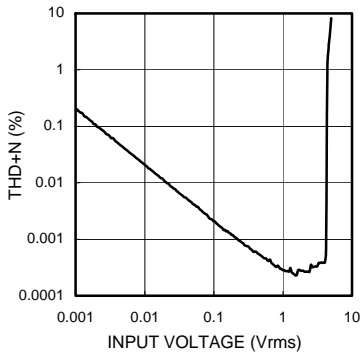

Fig.12 REC Total Harmonic Distortion - Input Voltage

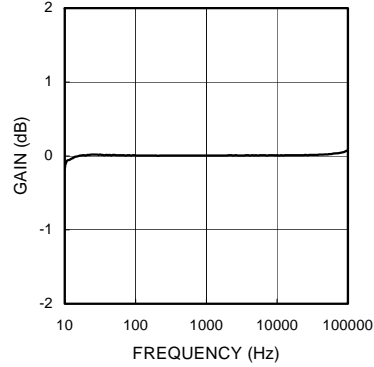

Fig.13 REC Voltage Gain - Frequency

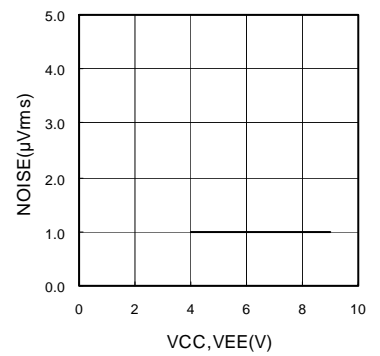

Fig.14 REC Output Noise - Supply Voltage

● Notes for use

1. Numbers and data in entries are representative design values and are not guaranteed values of the items.
2. Although ROHM is confident that the example application circuit reflects the best possible recommendations, be sure to verify circuit characteristics for your particular application. Modification of constants for other externally connected circuits may cause variations in both static and transient characteristics for external components as well as this Rohm IC. Allow for sufficient margins when determining circuit constants.
3. Absolute maximum ratings
Use of the IC in excess of absolute maximum ratings, such as the applied voltage or operating temperature range (T_{opr}), may result in IC damage. Assumptions should not be made regarding the state of the IC (short mode or open mode) when such damage is suffered. A physical safety measure, such as a fuse, should be implemented when using the IC at times where the absolute maximum ratings may be exceeded.
4. VEE potential
Make the VEE pin voltage such that it is the lowest voltage even when operating below it. Actually confirm that the voltage of each pin does not become a lower voltage than the VEE pin, including transient phenomena.
5. Thermal design
Perform thermal design, in which there are adequate margins, by taking into account the power dissipation (P_d) in actual states of use.
6. Short circuit between terminals and erroneous mounting
Pay attention to the assembly direction of the ICs. Wrong mounting direction or shorts between terminals, GND, or other components on the circuits, can damage the IC.
7. Operation in strong electromagnetic field
Using the ICs in a strong electromagnetic field can cause operation malfunction.
8. Operating Voltage Range and Operating Temperature Range
Circuit function actions are guaranteed within the action voltage range and the action temperature range. However, the specific values of the electrical characteristics are guaranteed under the specified conditions of the electrical characteristics. Therefore, carry out set considerations in sufficient consideration of IC characteristic fluctuations..
9. Power ON/OFF
 - (a) At power ON/OFF, a shock sound will be generated. Therefore, use MUTE on the set.
 - (b) When turning on power supplies, VEE and VCC should be powered on simultaneously, or VEE first followed by VCC. If the VCC side is started up first, an excessive current may flow from VCC to VEE.
10. Serial control
For the CL and DA terminals, the patterned and other wirings should be routed as not to cause interference with the analog-signal-related lines.
11. Function switching
For all functions, other than Master Volume, Treble, and Bass Gain Settings, use MUTE on the set.

● Ordering part number

B	D
---	---

Part No.

3	8	4	3
---	---	---	---

Part No.
3843
3841

F	S
---	---

Package
FS: SSOP-A24
SSOP-A32

E	2
---	---

Packaging and forming specification
None: Tray

SSOP-A24

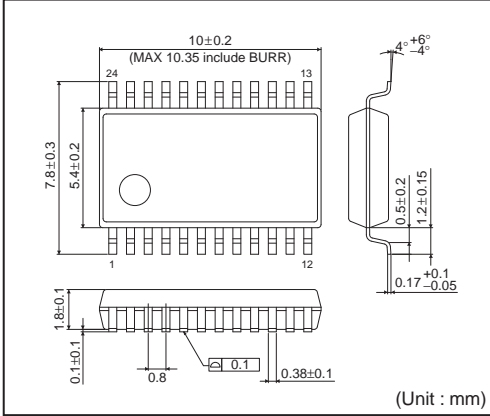

<Tape and Reel information>

Tape	Embossed carrier tape
Quantity	2000pcs
Direction of feed	E2 (The direction is the 1pin of product is at the upper left when you hold reel on the left hand and you pull out the tape on the right hand)

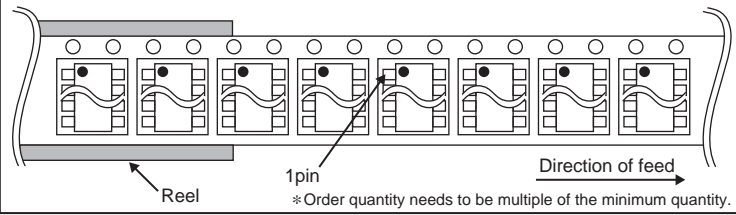

SSOP-A32

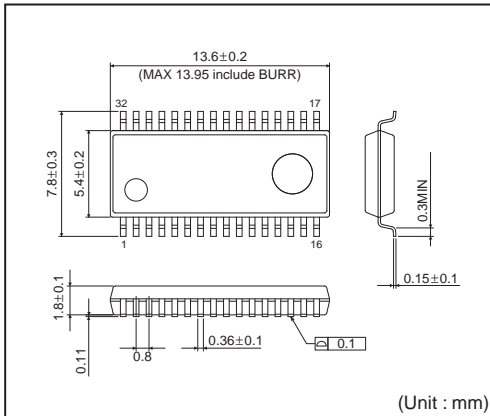

<Tape and Reel information>

Tape	Embossed carrier tape
Quantity	2000pcs
Direction of feed	E2 (The direction is the 1pin of product is at the upper left when you hold reel on the left hand and you pull out the tape on the right hand)

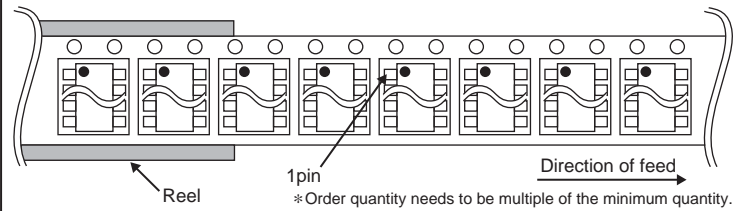

Notice

Precaution on using ROHM Products

- Our Products are designed and manufactured for application in ordinary electronic equipments (such as AV equipment, OA equipment, telecommunication equipment, home electronic appliances, amusement equipment, etc.). If you intend to use our Products in devices requiring extremely high reliability (such as medical equipment ^(Note 1), transport equipment, traffic equipment, aircraft/spacecraft, nuclear power controllers, fuel controllers, car equipment including car accessories, safety devices, etc.) and whose malfunction or failure may cause loss of human life, bodily injury or serious damage to property ("Specific Applications"), please consult with the ROHM sales representative in advance. Unless otherwise agreed in writing by ROHM in advance, ROHM shall not be in any way responsible or liable for any damages, expenses or losses incurred by you or third parties arising from the use of any ROHM's Products for Specific Applications.

(Note1) Medical Equipment Classification of the Specific Applications

JAPAN	USA	EU	CHINA
CLASS III	CLASS III	CLASS II b	CLASS III
CLASS IV		CLASS III	

- ROHM designs and manufactures its Products subject to strict quality control system. However, semiconductor products can fail or malfunction at a certain rate. Please be sure to implement, at your own responsibilities, adequate safety measures including but not limited to fail-safe design against the physical injury, damage to any property, which a failure or malfunction of our Products may cause. The following are examples of safety measures:
 - Installation of protection circuits or other protective devices to improve system safety
 - Installation of redundant circuits to reduce the impact of single or multiple circuit failure
- Our Products are designed and manufactured for use under standard conditions and not under any special or extraordinary environments or conditions, as exemplified below. Accordingly, ROHM shall not be in any way responsible or liable for any damages, expenses or losses arising from the use of any ROHM's Products under any special or extraordinary environments or conditions. If you intend to use our Products under any special or extraordinary environments or conditions (as exemplified below), your independent verification and confirmation of product performance, reliability, etc. prior to use, must be necessary:
 - Use of our Products in any types of liquid, including water, oils, chemicals, and organic solvents
 - Use of our Products outdoors or in places where the Products are exposed to direct sunlight or dust
 - Use of our Products in places where the Products are exposed to sea wind or corrosive gases, including Cl₂, H₂S, NH₃, SO₂, and NO₂
 - Use of our Products in places where the Products are exposed to static electricity or electromagnetic waves
 - Use of our Products in proximity to heat-producing components, plastic cords, or other flammable items
 - Sealing or coating our Products with resin or other coating materials
 - Use of our Products without cleaning residue of flux (even if you use no-clean type fluxes, cleaning residue of flux is recommended); or Washing our Products by using water or water-soluble cleaning agents for cleaning residue after soldering
 - Use of the Products in places subject to dew condensation
- The Products are not subject to radiation-proof design.
- Please verify and confirm characteristics of the final or mounted products in using the Products.
- In particular, if a transient load (a large amount of load applied in a short period of time, such as pulse. is applied, confirmation of performance characteristics after on-board mounting is strongly recommended. Avoid applying power exceeding normal rated power; exceeding the power rating under steady-state loading condition may negatively affect product performance and reliability.
- De-rate Power Dissipation (Pd) depending on Ambient temperature (Ta). When used in sealed area, confirm the actual ambient temperature.
- Confirm that operation temperature is within the specified range described in the product specification.
- ROHM shall not be in any way responsible or liable for failure induced under deviant condition from what is defined in this document.

Precaution for Mounting / Circuit board design

- When a highly active halogenous (chlorine, bromine, etc.) flux is used, the residue of flux may negatively affect product performance and reliability.
- In principle, the reflow soldering method must be used; if flow soldering method is preferred, please consult with the ROHM representative in advance.

For details, please refer to ROHM Mounting specification

Precautions Regarding Application Examples and External Circuits

1. If change is made to the constant of an external circuit, please allow a sufficient margin considering variations of the characteristics of the Products and external components, including transient characteristics, as well as static characteristics.
2. You agree that application notes, reference designs, and associated data and information contained in this document are presented only as guidance for Products use. Therefore, in case you use such information, you are solely responsible for it and you must exercise your own independent verification and judgment in the use of such information contained in this document. ROHM shall not be in any way responsible or liable for any damages, expenses or losses incurred by you or third parties arising from the use of such information.

Precaution for Electrostatic

This Product is electrostatic sensitive product, which may be damaged due to electrostatic discharge. Please take proper caution in your manufacturing process and storage so that voltage exceeding the Products maximum rating will not be applied to Products. Please take special care under dry condition (e.g. Grounding of human body / equipment / solder iron, isolation from charged objects, setting of ionizer, friction prevention and temperature / humidity control).

Precaution for Storage / Transportation

1. Product performance and soldered connections may deteriorate if the Products are stored in the places where:
 - [a] the Products are exposed to sea winds or corrosive gases, including Cl₂, H₂S, NH₃, SO₂, and NO₂
 - [b] the temperature or humidity exceeds those recommended by ROHM
 - [c] the Products are exposed to direct sunshine or condensation
 - [d] the Products are exposed to high Electrostatic
2. Even under ROHM recommended storage condition, solderability of products out of recommended storage time period may be degraded. It is strongly recommended to confirm solderability before using Products of which storage time is exceeding the recommended storage time period.
3. Store / transport cartons in the correct direction, which is indicated on a carton with a symbol. Otherwise bent leads may occur due to excessive stress applied when dropping of a carton.
4. Use Products within the specified time after opening a humidity barrier bag. Baking is required before using Products of which storage time is exceeding the recommended storage time period.

Precaution for Product Label

QR code printed on ROHM Products label is for ROHM's internal use only.

Precaution for Disposition

When disposing Products please dispose them properly using an authorized industry waste company.

Precaution for Foreign Exchange and Foreign Trade act

Since our Products might fall under controlled goods prescribed by the applicable foreign exchange and foreign trade act, please consult with ROHM representative in case of export.

Precaution Regarding Intellectual Property Rights

1. All information and data including but not limited to application example contained in this document is for reference only. ROHM does not warrant that foregoing information or data will not infringe any intellectual property rights or any other rights of any third party regarding such information or data. ROHM shall not be in any way responsible or liable for infringement of any intellectual property rights or other damages arising from use of such information or data.:
2. No license, expressly or implied, is granted hereby under any intellectual property rights or other rights of ROHM or any third parties with respect to the information contained in this document.

Other Precaution

1. This document may not be reprinted or reproduced, in whole or in part, without prior written consent of ROHM.
2. The Products may not be disassembled, converted, modified, reproduced or otherwise changed without prior written consent of ROHM.
3. In no event shall you use in any way whatsoever the Products and the related technical information contained in the Products or this document for any military purposes, including but not limited to, the development of mass-destruction weapons.
4. The proper names of companies or products described in this document are trademarks or registered trademarks of ROHM, its affiliated companies or third parties.

General Precaution

1. Before you use our Products, you are requested to carefully read this document and fully understand its contents. ROHM shall not be in any way responsible or liable for failure, malfunction or accident arising from the use of any ROHM's Products against warning, caution or note contained in this document.
2. All information contained in this document is current as of the issuing date and subject to change without any prior notice. Before purchasing or using ROHM's Products, please confirm the latest information with a ROHM sales representative.
3. The information contained in this document is provided on an "as is" basis and ROHM does not warrant that all information contained in this document is accurate and/or error-free. ROHM shall not be in any way responsible or liable for any damages, expenses or losses incurred by you or third parties resulting from inaccuracy or errors of or concerning such information.

X-ON Electronics

Largest Supplier of Electrical and Electronic Components

Click to view similar products for [Audio Amplifiers](#) category:

Click to view products by [ROHM](#) manufacturer:

Other Similar products are found below :

[LV47002P-E](#) [MP7747DQ-LF-P](#) [AZ386MTR-E1](#) [NCP2811AFCT1G](#) [NCP2890AFCT2G](#) [NJM8068RB1-TE1](#) [NJV1194V-TE1](#) [LA4282-E](#)
[LA4814JA-AE](#) [LC706200CM](#) [SSM2377ACBZ-R7](#) [FDA2100LV](#) [TDA2541](#) [TDA7385H](#) [TDA7391LV](#) [TDA7575BPDTR](#) [TDA7718NTR](#)
[IS31AP2121-LQLS1](#) [IS31AP4915A-QFLS2-TR](#) [LA74309FA-BH](#) [421067X](#) [480263C](#) [NCP2820FCT2G](#) [STPA001](#) [TDA1515AQ](#) [TDA1520B](#)
[TDA1591T](#) [TDA2051H](#) [TDA4850](#) [TDA7391PDUTR](#) [TDA7563BH](#) [TDA7718B](#) [LA4425F-E](#) [LA4742-E](#) [TDA7391PDU](#)
[TDA7491MV13TR](#) [TDA749213TR](#) [TDA7563AH](#) [TDA7850H](#) [STK433-070GN-E](#) [E-TDA7391PDTR](#) [SSM2529ACBZ-R7](#) [SSM2518CBZ-](#)
[R7](#) [MAX9890BEBL+T](#) [MAX98303EWE+T](#) [MAX98358EWL+](#) [MAX98304DEWL+T](#) [MAX97220DETE+T](#) [TS4962MEIJT](#) [TS4990EIJT](#)