

Driver for Digital Still Camera

1-2ch Lens Drivers for SLRs (Single-lens Reflex)



BD65499MUV

●General Description

The BD65499MUV motor driver provides built-in boost converter and 1ch H-bridge FULL ON driver. Integrated boost converter for high voltage and large current H-bridge, especially designed for mobile system piezoelectric element with a compact surface mount package.

●Features

- Low ON resistance DMOS output
- DC/DC boost converter
- Output switching speed changeability (DC/DC converter: 4 step, H-bridge: 2 step)
- Charge pump less as using Pch DMOS for high-side output (H-bridge)
- Control input terminal available with 1.8V
- With built-in Under Voltage Locked Out protection, Thermal Shut Down, and Over Current Protection circuit

●Applications

- Small mobile system
- Home appliance
- Amusement system, etc

●Key Specifications

- Power supply voltage (V_{CC}): 2.7 to 3.6V
- Motor power supply voltage (V_P): 4.0 to 27.0V
- Circuit current: 2.8mA(Typ.)
- Stand-by current: 1μA (Max.)
- Control input voltage: 0 to V_{CC} V
- Control input frequency: 300kHz(Max.)
- Serial clock input frequency: 5MHz(Max.)
- Turn On time: 150ns(Typ.)
- Turn Off time: 50ns(Typ.)
- H-bridge output current (DC): 500mA
- Motor voltage supply output current (DC): 300mA
- DC/DC converter switching frequency: 750kHz(Typ.)
- Output ON resistance
 - DC/DC converter Nch. DMOS: 0.20Ω(Typ.)
 - H-bridge (total): 0.60Ω(Typ.)
- Operating temperature range: -30 to 85°C

●Package

VQFN028V5050

W(Typ.) x D(Typ.) x H(Max.)
5.00mm x 5.00mm x 1.00mm

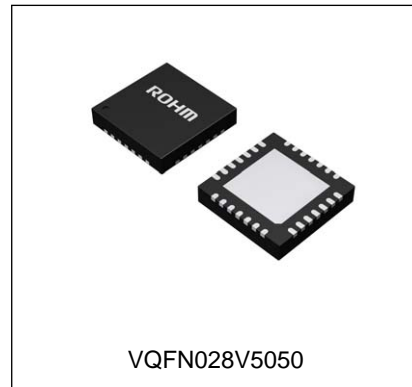

●Ordering Information

B D 6 5 4 9 9 M U V	-	E 2
Part Number	Package MUV: VQFN028V5050	Packaging and forming specification E2: Embossed tape and reel

●Block Diagram / Application Example

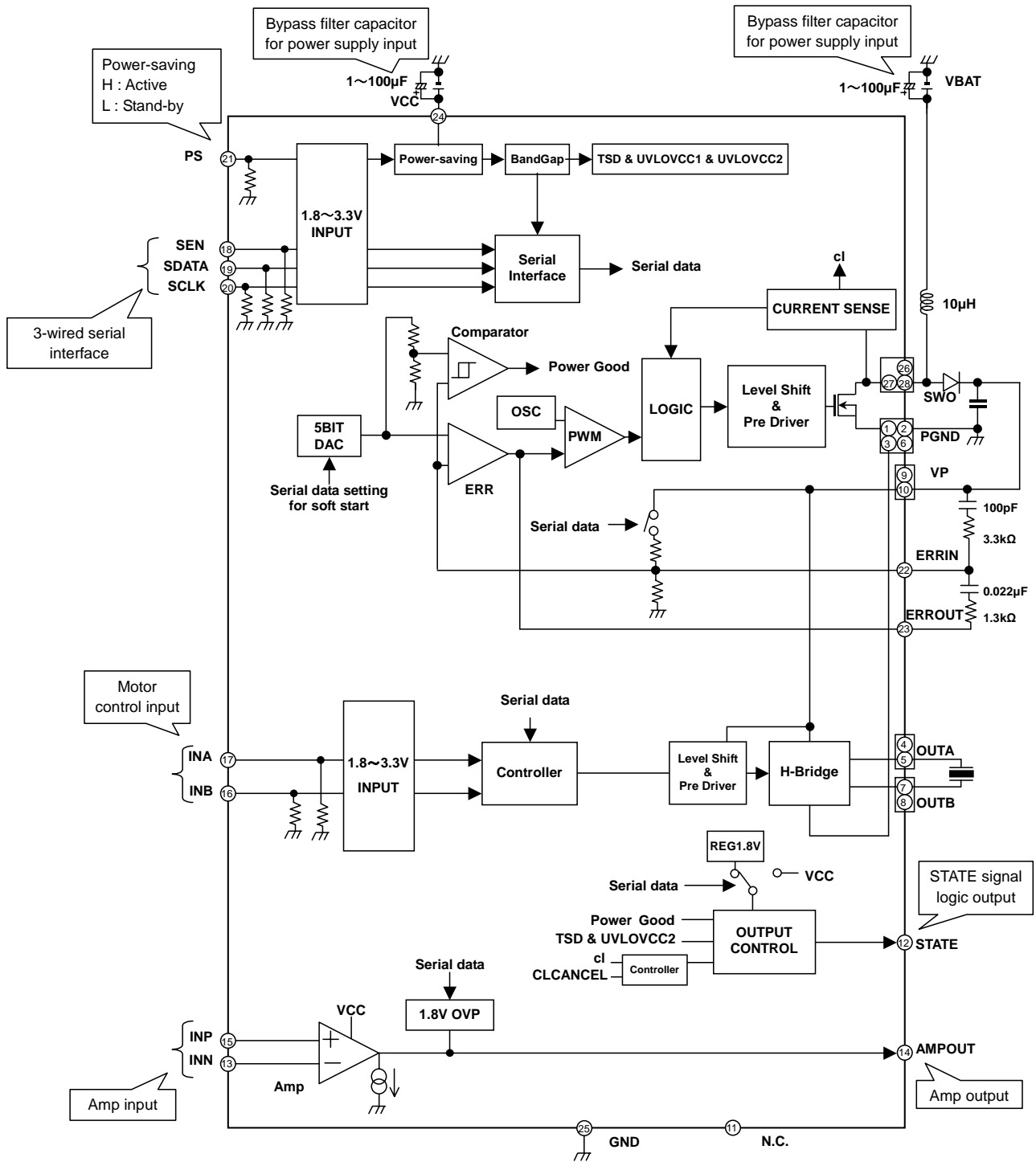

Figure 1. Block diagram

● Pin Configuration

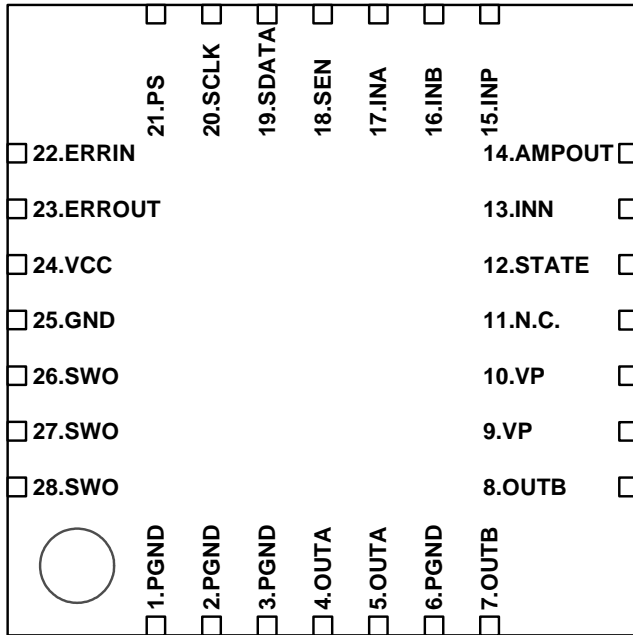

Figure 2. Pin Configuration (Top View)

● Pin Description

Pin No.	Terminal	Function	PS=Lo condition
25	GND	Ground terminal	-
1,2,3,6	PGND	Power ground terminal	-
24	VCC	Small signal power supply terminal	-
11	N.C.	N.C.	-
9,10	VP	VP power supply terminal	-
26,27,28	SWO	Nch power FET output terminal	HiZ
4,5	OUTA	H-bridge output terminal ch.A	HiZ
7,8	OUTB	H-bridge output terminal ch.B	HiZ
17	INA	Control input terminal A	Lo
16	INB	Control input terminal B	Lo
12	STATE	STATE output terminal	Lo
15	INP	Amp plus input terminal	HiZ
13	INN	Amp minus input terminal	HiZ
14	AMPOUT	Buffer Amp output terminal	HiZ
22	ERRIN	Error Amp input terminal	Lo
23	ERROUT	Error Amp output terminal	Lo
21	PS	Power-saving terminal	Lo
18	SEN	3-wired serial enable input terminal	Lo
19	SDATA	3-wired serial data input terminal	Lo
20	SCLK	3-wired serial clock input terminal	Lo

* Short-circuit on an implementation pattern about the following each of the same terminal name. Power ground (PGND), VP power supply terminal (VP), Nch power FET output terminal (SWO), H-bridge output terminal ch.A (OUTA), H-bridge output terminal ch.B (OUTB).

● Absolute Maximum Ratings

Parameter	Symbol	Limit	Unit
Power supply voltage	V_{CC}	-0.3 to +4.5	V
VP Power supply voltage	V_P	-0.3 to +30.0	V
SWO supply voltage	V_{SWO}	-0.3 to +30.0	V
Control input voltage	V_{IN}	-0.3 to $V_{CC} + 0.3$	V
Amp input and output voltage	V_{AMP}	-0.3 to $V_{CC} + 0.3$	V
Power dissipation 1	$Pd1$	880 ^{*1}	mW
Power dissipation 2	$Pd2$	3260 ^{*2}	mW
Power dissipation 3	$Pd3$	4560 ^{*3}	mW
Junction temperature	T_{jmax}	150	°C
Storage temperature range	T_{stg}	-55 to +150	°C
VP power supply load current (DC)	I_{VPDC}	-300 to +300 ^{*4}	mA
VP power supply load current (peak ^{*5})	I_{VPP}	-500 to +500 ^{*4}	mA
H-bridge output current (DC)	I_{OUT}	-500 to +500 ^{*4}	mA
H-bridge output current (peak 1 ^{*6})	I_{OUTP1}	-1000 to +1000 ^{*4}	mA
H-bridge output current (peak 2 ^{*7})	I_{OUTP2}	-2000 to +2000 ^{*4}	mA

^{*1} Reduced by 7.0mW / °C , when mounted on a one layer glass epoxy board (74.2mm × 74.2mm × 1.6mm front and back radiation of heat copper foil 20.2mm² , Ta=25°C)

^{*2} Reduced by 26.0mW / °C , when mounted on a four layers glass epoxy board (74.2mm × 74.2mm × 1.6mm front and back radiation of heat copper foil 20.2mm² , 2nd and 3rd radiation of heat copper foil 5505mm² , Ta=25°C).

^{*3} Reduced by 36.4mW / °C , when mounted on a four layers glass epoxy board (74.2mm × 74.2mm × 1.6mm , All layers radiation of heat copper foil 5505mm² , Ta=25°C).

^{*4} Pd, ASO, and never exceed $T_{jmax}=150^{\circ}C$.

^{*5} A peak electric current value after having smoothed by 20μF bypass condenser which is connected between VP and GND.

And which is drifted when the H-bridge works as Forward / Reverse.

^{*6} On time ≤ 10μs and Duty ≤ 30%.

^{*7} On time ≤ 5μs and Duty ≤ 15%.

● Recommended Operating Ratings

Parameter	Symbol	Limit	Unit
Power supply voltage	V_{CC}	2.7 to 3.6	V
VP power supply voltage	V_P	4.0 to 27.0	V
SWO supply voltage	V_{SWO}	4.0 to 27.0	V
Control input voltage	V_{IN}	0 to V_{CC}	V
Amplifier input-output voltage	V_{AMP}	0 to V_{CC}	V
INA, INB input frequency	F_{IN}	0 to 300	kHz
SCLK frequency	S_{CL}	0 to 5	MHz
Operating temperature range	T_{opr}	-30 to 85	°C

* VP supply voltage contains soft start mode ($V_P = 4V$ to 14V). VP voltage setting range is 14 to 25V.

●Electrical Characteristics (Unless otherwise specified Ta=25°C, V_{CC}=3.3V, V_{BAT}=8V, V_P=20V)

Parameter	Symbol	Limit			Unit	Conditions
		Min.	Typ.	Max.		
All circuits						
Circuit current during stand-by operation	I _{CCST}	-	0	1	μA	Stand-by mode PS=0V
Circuit current	I _{CC}	1.5	2.8	5.0	mA	Active mode PS =Hi,ERRIN= V _{CC} , INP= V _{CC} /2,INN=AMPOUT
Control input (IN= PS, INA, INB, SEN, SCLK, SDATA)						
High-level input voltage	V _{INH}	1.45	-	V _{CC}	V	
Low-level input voltage	V _{INL}	0	-	0.5	V	
High-level input current	I _{INH}	15	30	60	μA	V _{IN} =3V
Low-level input current	I _{INL}	-1	0	1	μA	V _{IN} =0V
Logic output (OUT=STATE)						
Hi output 0	H _{O0}	1.6	1.8	2.0	V	LSET=1'b0 no load mode
Hi output 1	H _{O1}	V _{CC} -0.3	V _{CC} -0.15	-	V	LSET=1'b1 0.5mA source condition
Lo output	L _O	-	0.15	0.3	V	0.5mA sink condition
Under voltage Locked out (UVLO circuit)						
UVLO voltage 1(VCC)	V _{UVLO1VCC}	1.8	-	2.2	V	Serial data reset
UVLO voltage 2(VCC)	V _{UVLO2VCC}	2.25	-	2.65	V	SWO output, H bridge output, AMPOUT : OFF
UVLO voltage difference 12(VCC)	V _{UVLO12VCC}	0.1	0.4	0.75	V	The difference voltage between each UVLO start voltage of Serial data set and out put OFF
FULL ON driver block						
Output ON resistance	R _{ON}	-	0.60	0.85	Ω	High-side and Low-side ON resistance total
Turn On time 0	T _{on0}	-	300	700	ns	TR=1'h0
Turn On time 1	T _{on1}	-	150	500	ns	TR=1'h1
Turn Off time	T _{off0}	-	50	400	ns	TR=1'hx
Amp						
Common mode input voltage range	V _{LOPI}	0.1	-	V _{CC} -0.1	V	INP voltage input ,INN=AMPOUT (no load)
Input bias current	I _{BI}	-3	0	3	μA	
Output source current	I _{OH}	2.5	-	-	mA	INP= V _{CC} /2,INN=AMPOUT
Output sink current	I _{OL}	0.2	0.3	-	mA	INP= V _{CC} /2,INN=AMPOUT
Slew Rate	S _R	0.7	1.5	-	V/μs	INP=1 to 2V (or 2 to 1V) input, INN=AMPOUT, reaction velocity
GB width product	G _B	1.0	3.0	-	MHz	
Over voltage protection	O _{VP}	1.6	1.8	2.0	V	In case of AMPOVP=1'd1
STEP UP DC/DC converter						
Output Nch. ON resistance	D _{CRON}	-	0.20	0.50	Ω	
Oscillation frequency	D _{COSEC}	600	750	900	kHz	
Soft start	SS _{ST}	4.26	5.33	6.40	ms	SSSET=3'd5
Reference voltage 14	S _{V14}	13.58	14.0	14.42	V	VPSET=5'd14
Reference voltage 20	S _{V20}	19.5	20.0	20.5	V	VPSET=5'd20
Reference voltage 25	S _{V25}	24.5	25.0	25.5	V	VPSET=5'd25
Power Good	P _G	83	90	97	%	(VP voltage after soft start completion)[V] x PG[%]
Power Good hysteresis	P _{GHYS}	63	70	77	%	(VP voltage after soft start completion)[V] x PGHYS[%]
Current limit	D _{CLIM}	2.0	3.6	-	A	SWO current

● Typical Performance Curves

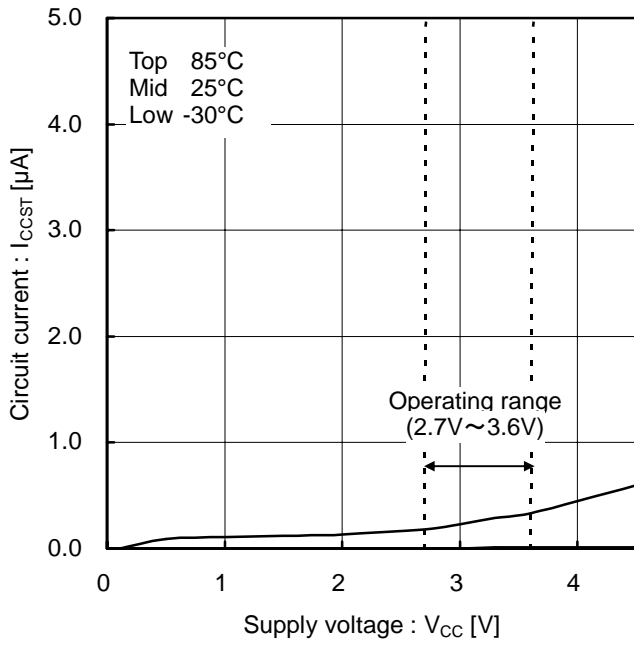

Figure 3. Stand-by mode circuit current

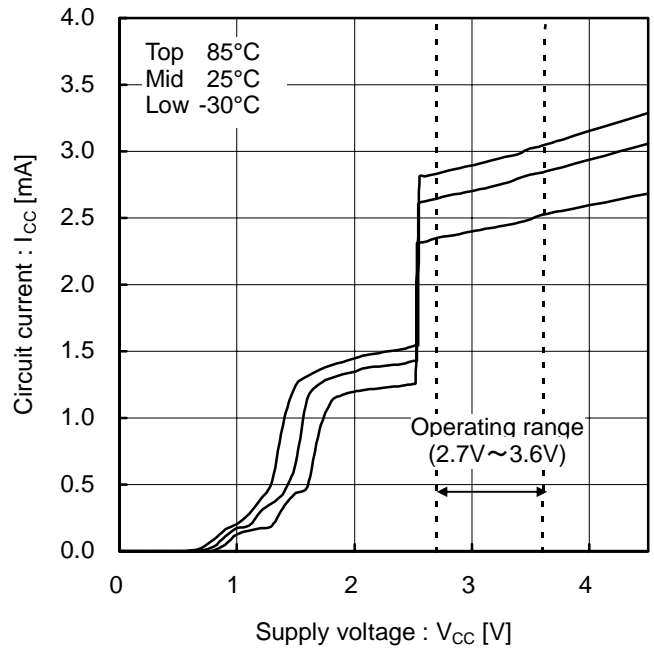

Figure 4. Circuit current

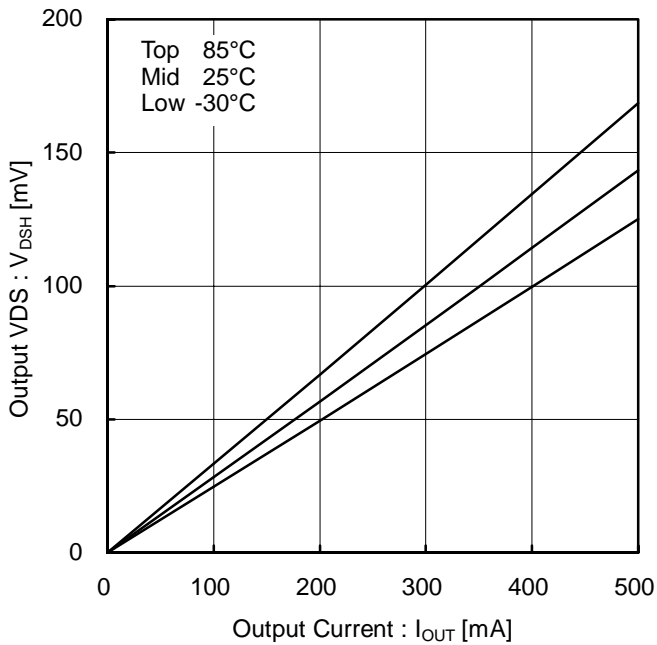

Figure 5. H-bridge output High-side ON resistance
($V_P=20V$, $V_{CC}=3.3V$)

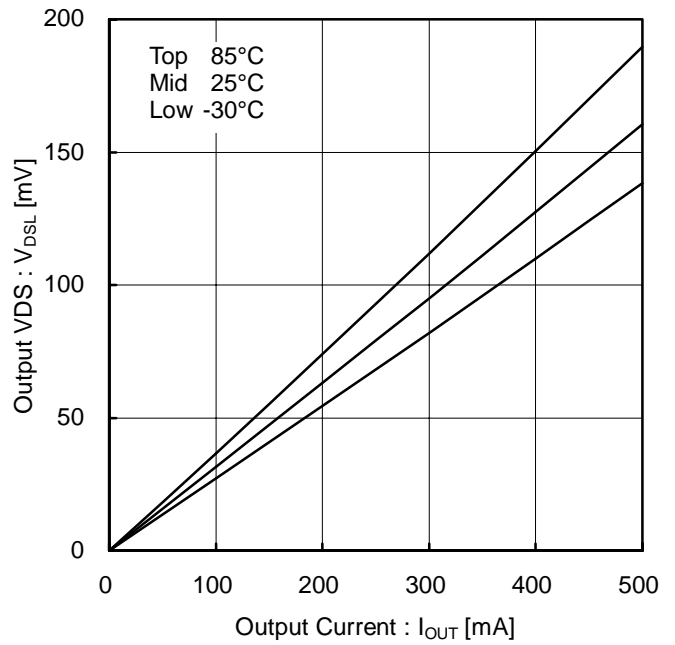

Figure 6. H-bridge output Low-side ON resistance
($V_P=20V$, $V_{CC}=3.3V$)

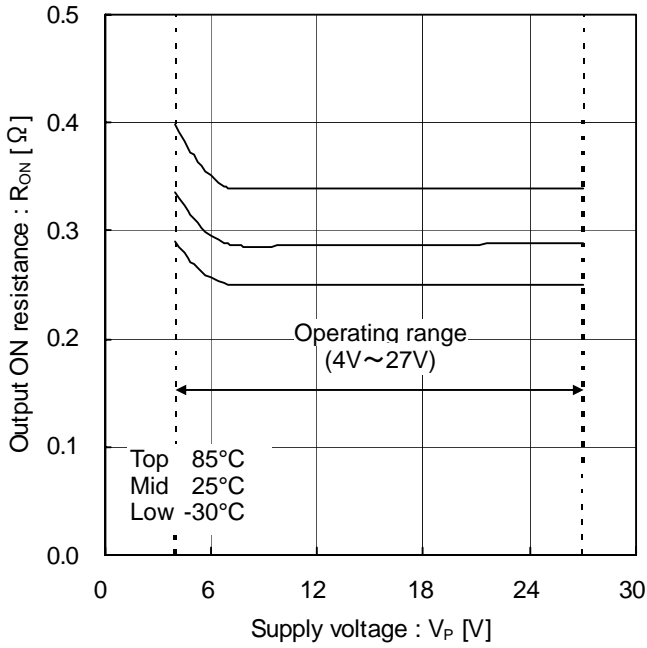

Figure 7. H-bridge output High-side ON resistance (V_P dependency, $V_{CC}=3.3V$)

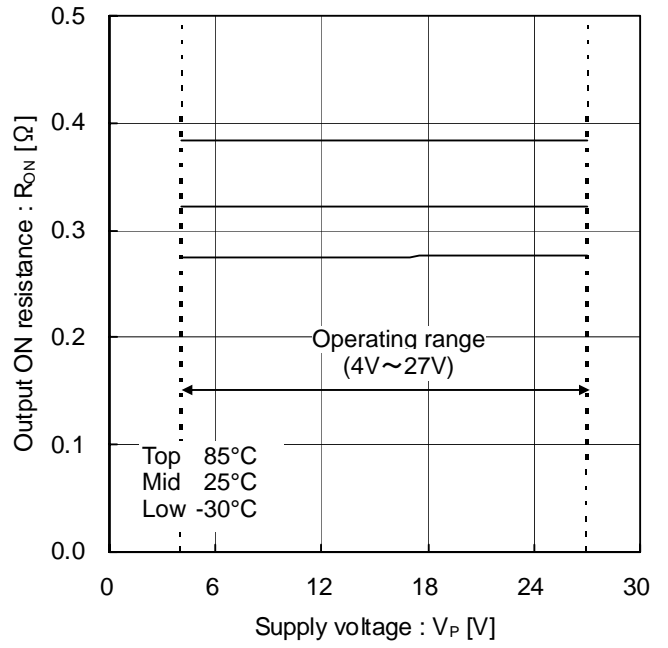

Figure 8. H-bridge output Low-side ON resistance (V_P dependency, $V_{CC}=3.3V$)

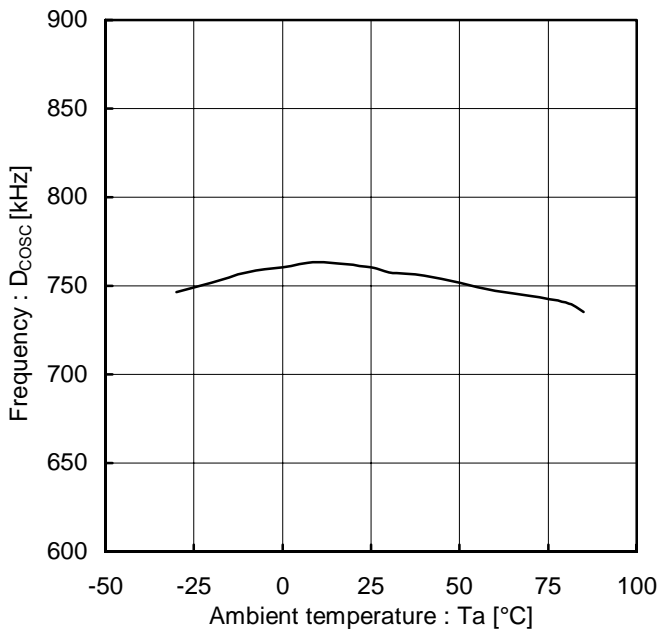

Figure 9. DC/DC switching frequency (Temperature dependency)

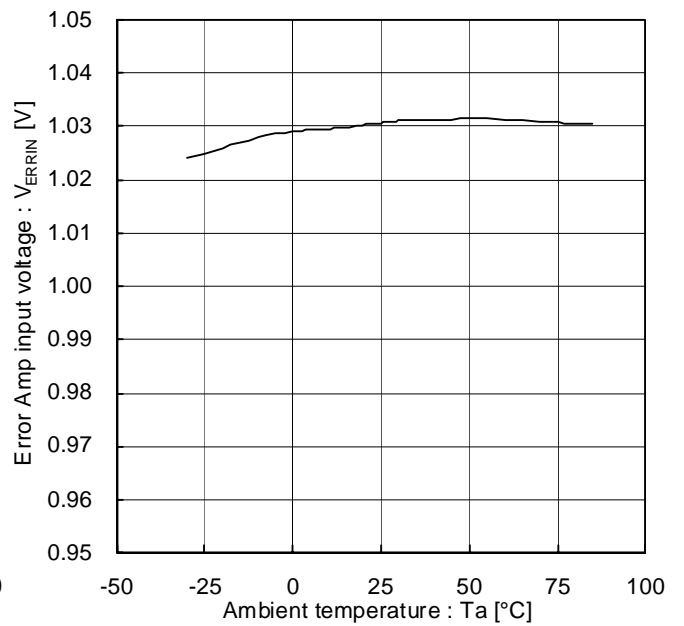

Figure 10. Error amplifier threshold voltage (Temperature dependency)

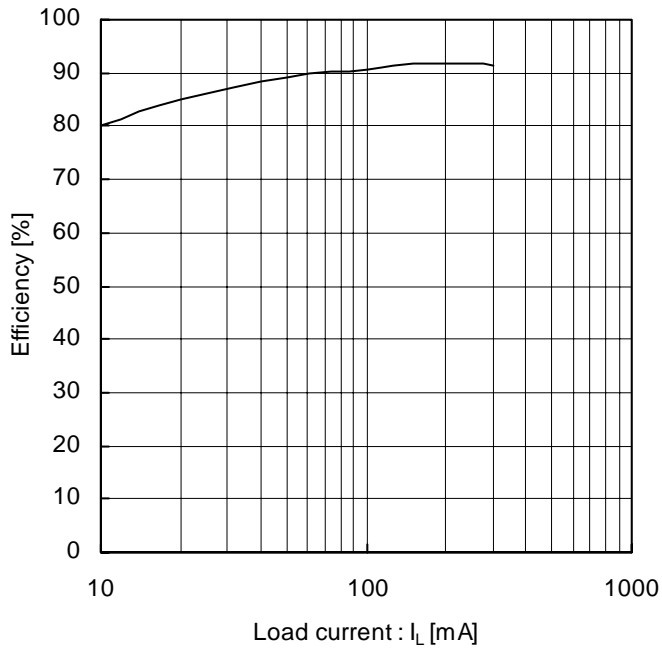

Figure 11. DC/DC power conversion efficiency
($V_{BAT}=6V$, $V_P=20V$)

●Function Description

(1) Reset

Mode	PS terminal	CLCANCEL	cl	STATE terminal (STATESEL=3'd0)	SWO output	H-bridge output
Stand-by mode	L	0 (reset)	1	L	HiZ	HiZ
Circuit start up and the voltage boost start	H (after ic=1)	0	1	L	Normal	Normal
Condition that the voltage boost complete	H	0	1	H	Normal	Normal
In case that it takes UVLOVCC1 (Serial data set)	H	0 (reset)	1	L	HiZ	HiZ
In the case that it takes UVLOVCC2 or TSD	H	0	1	L	HiZ	HiZ
SWO current limit	H	0	0	L	Latched in HiZ	Latched in HiZ
STATE terminal output CI invalid	H	1	1 (set)	H	Normal or *8	Normal

* Regarding the return of UVLOVCC2 and TSD, The VP voltage setting DAC output soft starts from 0V.

* When it takes current limit three times consecutively in CLCANCEL=1'b0, It stop the SWO output and H bridge output. As for the return of the current limit, it is reset the PS terminal. (refer to Figure 12).

*8 When the SWO output is ON, it does sense of an SWO output current. And when its value is more than current I Current limit, it makes SWO output HiZ. The movement in CLCANCEL=1'b1 is Figure 13.

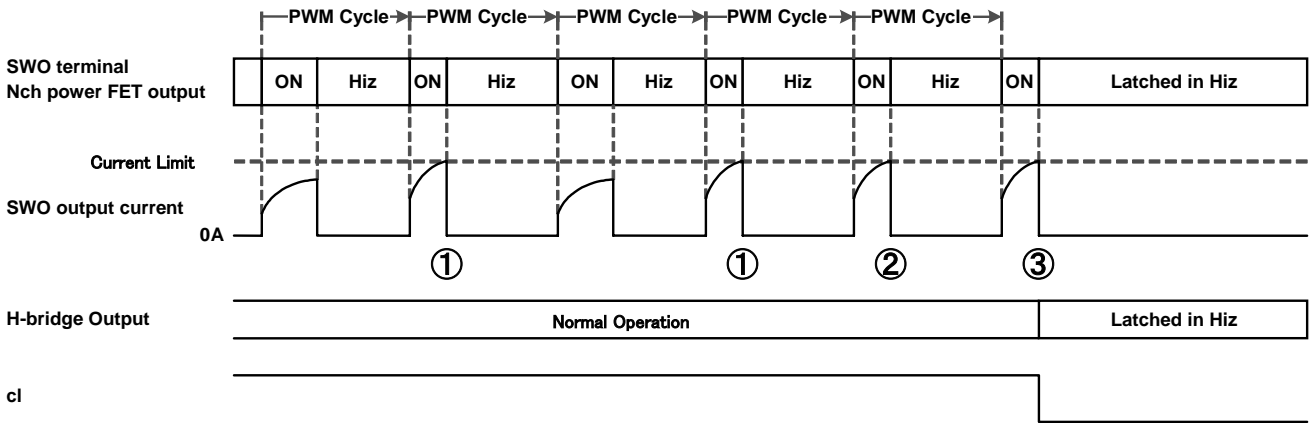

Figure 12. SWO output current limit timing chart
CLCANCEL=1'd0 cl Effective

Latched SWO and H-bridge in HiZ when the current limit detect three times consecutively

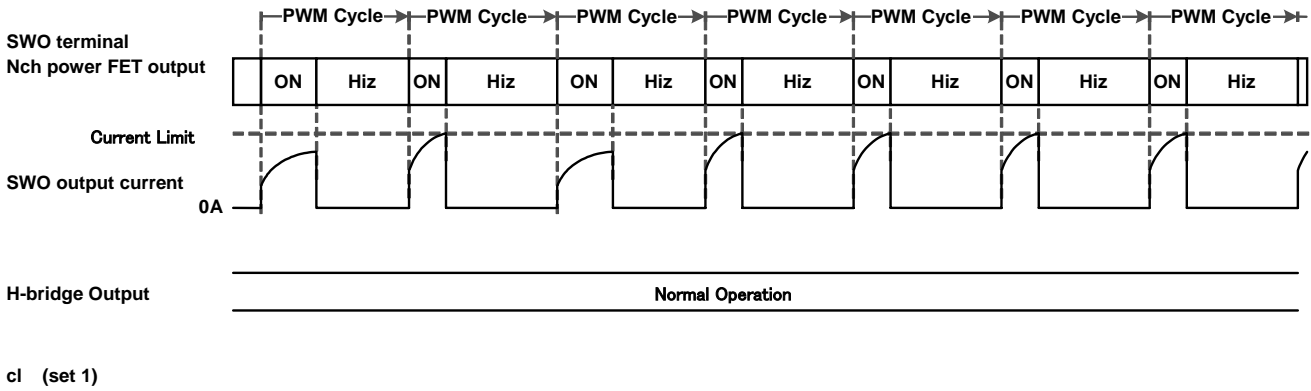

Figure 13. SWO output current limit timing chart
CLCANCEL=1'd1 cl invalidity

(2) Logic output setting, STATE terminal output voltage

LSET	STATE terminal output
0	0 / 1.8V output
1	0 / V _{CC} output

(3) Selection of the internal output signal of STATE terminal

STATESEL =3'd	Signal name	Function
0	ic & Power Good & uvlovcc2 & tsd & (cl CLCANCEL)	ic, Power Good, UVLOVCC2, TSD, (cl CLCANCEL) .If any one of those signals is "0"(stand-by or abnormal condition) outputs Lo.
1	S_POWERGOOD & S_UVLOVCC2 & S_TSD & S_(cl CLCANCEL)	S_POWERGOOD, S_UVLOVCC2, S_TSD, S_(cl CLCANCEL) If any one of those signals is "0"(stand-by or abnormal condition) outputs Lo.
2	ic	Normal circuit condition signal (In stand-by mode, it outputs Lo signal)
3	S_POWERGOOD	Power Good signal for the latch (Original signal is Power Good)
4	S_UVLOVCC2	VCCUVLO2 signal for the latch (Original signal is uvlovcc2) (In UVLO active mode, it outputs Lo signal)
5	-	-
6	S_TSD	Thermal shut down signal for the latch (Original signal is TSD) (In Thermal shutdown condition, it outputs Lo signal)
7	S_(cl CLCANCEL)	Current limit signal for the latch (Original signal is (cl CLCANCEL)

* "&" means AND logic. "|" means OR logic.

(4) STATE terminal output voltage setting

Mode	PS terminal	STATESET	S_POWERGOOD & S_UVLOVCC2 & S_TSD & S_(cl CLCANCEL)	S_POWERGOOD	S_UVLOVCC2	S_TSD	S_(cl CLCANCEL)
			STATESEL=3'd1	STATESEL=3'd3	STATESEL=3'd4	STATESEL=3'd6	STATESEL=3'd7
Stand-by mode	L	0	L (reset)	L (reset)	L (reset)	L (reset)	L (reset)
V _{CC} < V _{UVLO1VCC} condition	H	0	L (reset)	L (reset)	L (reset)	L (reset)	L (reset)
Circuit start up and the voltage boost start	H (after ic=1)	0	L	L	H	H	H
Condition that the voltage boost complete	H	0	L→H	L→H	H	H	H
In the condition of Boost voltage < (setting 70%)	H	0	H→L (latch)	H→L (latch)	H (fix)	H (fix)	H (fix)
In the case of V _{UVLO1VCC} < V _{CC} < V _{UVLO2VCC}	H	0	H→L (latch)	H (fix)	H→L (latch)	H (fix)	H (fix)
In the case of TSD	H	0	H→L (latch)	H (fix)	H (fix)	H→L (latch)	H (fix)
In the case of CLCANCEL=1'b0 and Current limit condition	H	0	H→L (latch)	H (fix)	H (fix)	H (fix)	H→L (latch)
In the condition of STATESET=1'b1	H	1	H (set)	H (set)	H (set)	H (set)	H (set)

* At the time of the falling edge of STATE terminal, it does latch the first changing signal from 1 to 0 in S_POWERGOOD, S_UVLOVCC2, S_TSD, S_(cl | CLCANCEL) and other signals are hold as 1.

* At the time of a change VPSET[3:0], it ignore the falling edge of the STATE terminal.

(5) Operation timing chart

Item	Symbol	Max.	Unit
$V_{CC} > V_{UVLO1VCC}$ and the time after(PS=Lo to Hi) until 3 wire communication	T_{EN}	100	μs
Start up(PS=Lo to Hi) , $V_{CC} > V_{UVLO2VCC}$ and the time after the cancellation TSD until normal condition	T_{RETURN}	100	μs

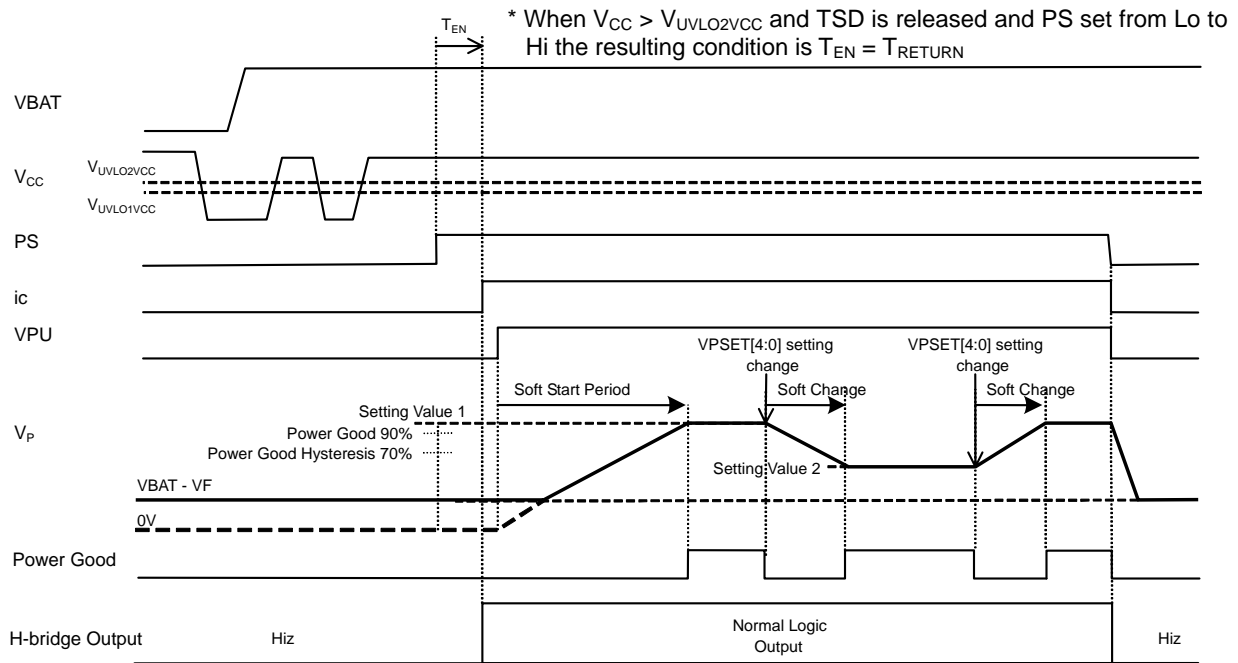

Figure 14. Start up and Stop sequence

*The period of soft start and soft change is Power Good=1'b0(fix).
 After soft start and soft change, 90% of setting value and Power Good=1'b1.
 With hysteresis, it is 70% and Power Good=1'b0.

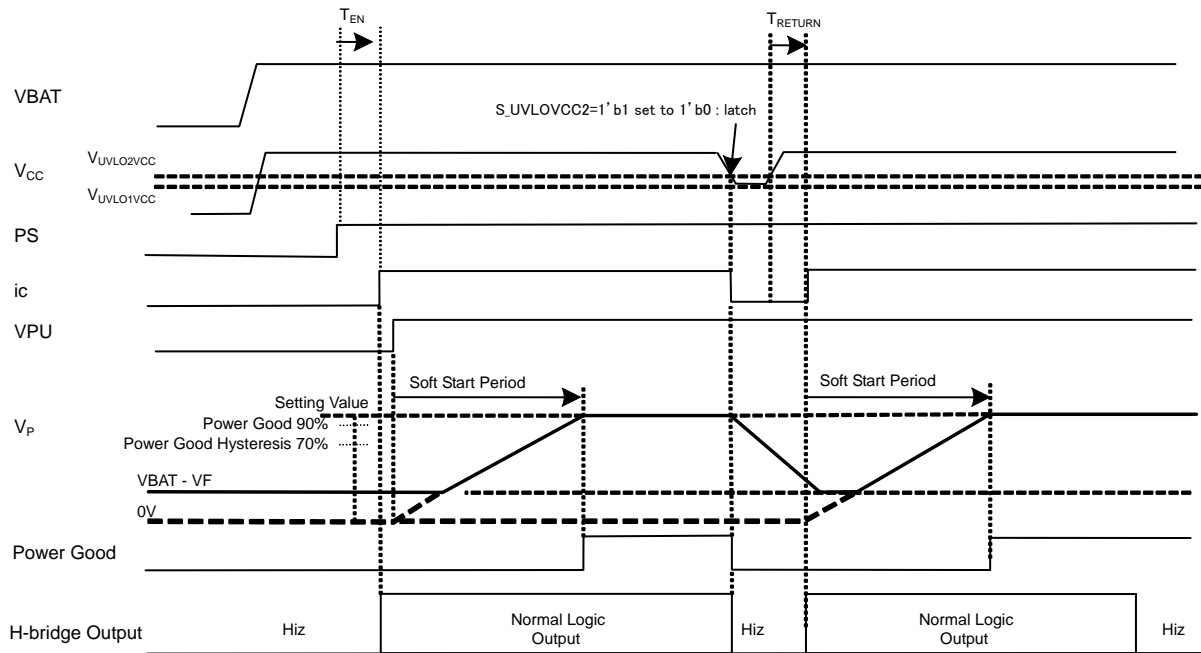

Figure 15. UVLOVCC2 (or TSD) operation and cancellation sequence

(6) AMPOUT terminal over voltage protection circuit

1. Monitoring AMPOUT voltage, And when it reach more than 1.8V, it make Class-A Amp output Pch. CMOS(M1) OFF and stop the energy supply from VCC.
2. Because the constant current I is active, it decrease the voltage in high value of AMPOUT toward GND direction.
3. It returns when the voltage of AMPOUT is less than 1.8V(typ.)

AMPOVP	AMPOUT1.8V over voltage protection
0	OFF (Default)
1	ON

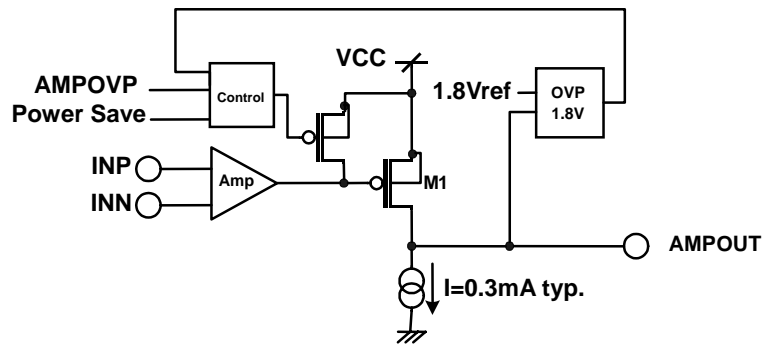

Figure 16. Over voltage protection circuit of AMP block

(7) In the case of amplifier unused

Use with connecting INN = AMPOUT terminal, and INP = GND.

●Boost Converter Block Explanation

(1)Output voltage setting

VPSET =5'd	VP voltage	VPSET =5'd	VP voltage	VPSET =5'd	VP voltage	VPSET =5'd	VP voltage
-	V	-	V	-	V	-	V
0	SWO HiZ	8	inhibited	16	16	24	24
1	inhibited	9		17	17	25	25
2		10		18	18	26	inhibited
3		11		19	19	27	
4		12		20	20	28	
5		13		21	21	29	
6		14		22	22	30	
7		15		23	23	31	

* With the application circuit as Figure 1, $V_p=V_{BAT}-V_F$ when $VPU=1'b0$.

(2)Soft start / soft change setting

SSSET =4'd	Soft start setting	SSSET =4'd	Soft start setting
-	ms/25V	-	ms/25V
0	5.33(default)	8	8.53
1	1.07	9	9.60
2	2.13	10	10.67
3	3.20	11	11.73
4	4.27	12	12.80
5	5.33	13	13.87
6	6.40	14	14.93
7	7.47	15	16.00

* Typical time between starting step up and finishing soft start at VPSET[4:0]=5'd25 (25V)setting.

Ex.) VPSET[4:0]=5'd14 (VP voltage is 14V setting), SSSET[3:0]=4'd5 (=5.33ms/25V)
 Soft start time = (VPSET setting voltage[V]) × (SSSET setting time[ms/25V]) / 25[V]
 = 14[V] × 5.33[ms/25V] / 25[V]
 = 2.98ms

(3) SWO switching speed control function

* As considering efficiency and switching noise to VCC voltage supply, default setting value of PON and NON[1:0] are determined.

PON =1'b	VCC side switching speed control	Comment
0	P2 operate	default
1	P3 operate	Use to reduce the noise at SWO turning ON

NON =2'b	PGND side switching speed control	Comment
00	N1 operate	default
01	N2 operate	Use to reduce the noise at SWO turning OFF
1x	N3 operate	Use to reduce the noise at SWO turning OFF

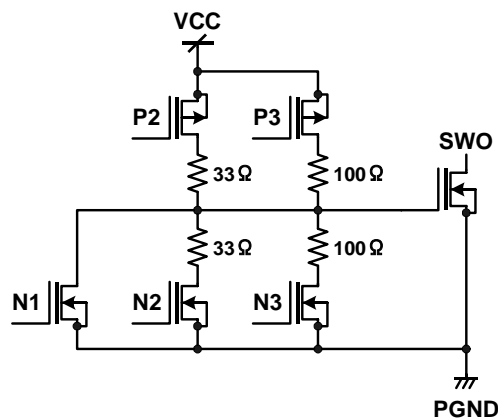

Figure 17. SWO circuit

(4) Power good filter function

Power good filter works when V_P drops lower than 70%(typ.) of V_P setting voltage, and the filter is reset when V_P voltage increase higher than 90%(typ.) of V_P setting voltage. When V_P drops lower than 70% and it takes longer than 5.3ms (typ.) to recover, Power Good signal turns from Hi to Lo.

* When PGFIL_₁'b0(default), power good filter is enabled, and when PGFIL_₁'b1, disabled.

Conditions $T_a=25^{\circ}\text{C}$, $V_{CC}=3.3\text{V}$

Items	Design value			Units
	Min.	Typ.	Max.	
Power good filter time	4.2	5.3	6.4	ms

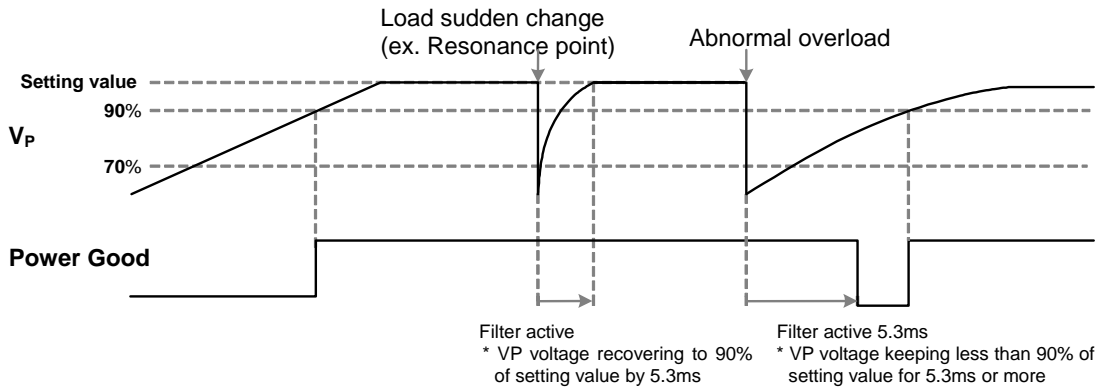

Figure 18. Power good filter timing chart
PGFIL_₁'b0(default) setting

(5) Over voltage protection

When V_P voltage increase +15%(typ.) more than V_P setting voltage(or indicated setting voltage in soft start / soft change time), OVP works and output of SWO turns to HiZ. OVP detect threshold voltage has hysteresis, and after OVP works when V_P terminal voltage becomes under +10%(typ.) more than V_P setting voltage, SWO switching restarts OVP function doesn't work when in stand-by state or $V_{PU}=1'b0$.

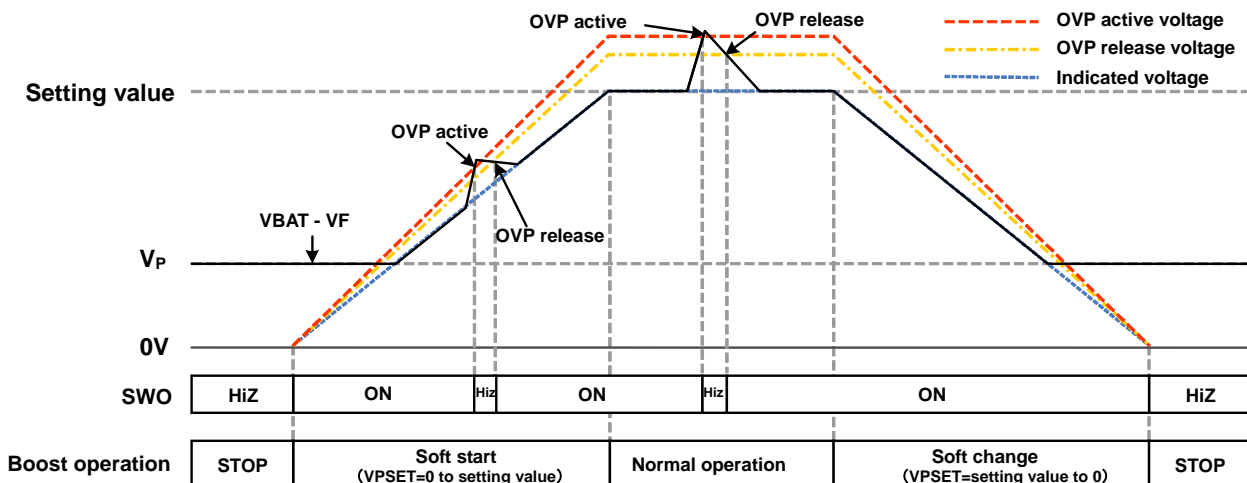

Figure 19. OVP function timing chart

●H-bridge Block

(1) H-bridge input and output truth table

Input method	INPUT				OUTPUT		
	PS* ⁹	MODE	INA	INB	OUTA	OUTB	Output mode
EN/IN	H	0 (default)	L	X	L	L	Short brake
			H	L	H	L	Forward
			H	H	L	H	Reverse
IN/IN		1	L	L	Z	Z	Open(default)
			H	L	H	L	Forward
			L	H	L	H	Reverse
			H	H	L	L	Short brake
-	L	X	X	X	Z	Z	Open

L; Low, H; High, X; Don't care, Z; Hi impedance

*⁹ PS terminal input logic High; IC active condition, Low; IC stand-by condition

(2) Output switching speed

Condition Ta=25°C, V_{CC}=3.3V, V_P=20V, Load 100Ω Unit: ns

TR	Turn On Time (T _{ON})	Turn Off Time (T _{OFF})	Rise Time (T _R)	Fall Time (T _F)	Dead Time (Dead Time)
1'h0	300	50	350	20	80
1'h1	150	50	50	20	70

* Dead Time in generated by internal timer.

* Rise Time and Fall Time are defined by the ability of pre-driver of H-bridge.

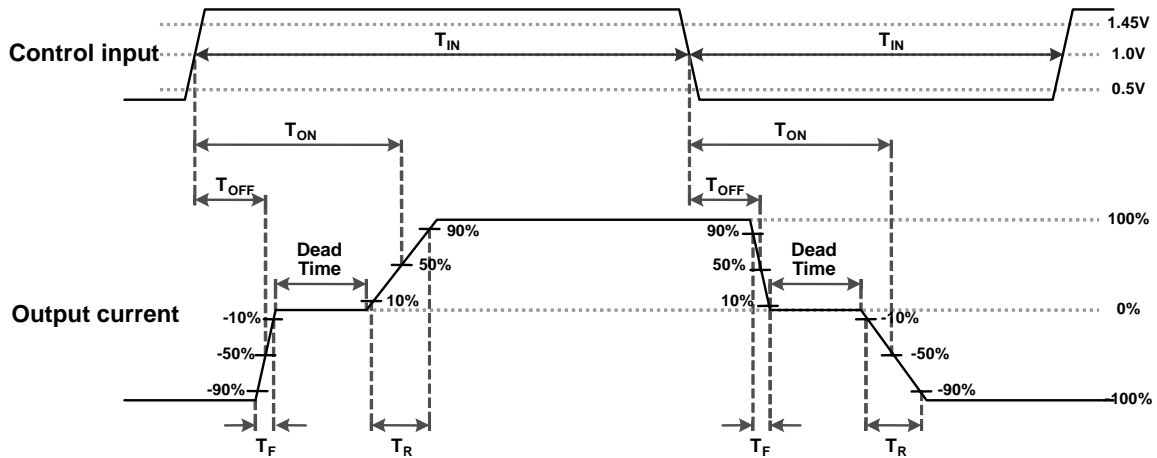

Figure 20. Definition of input-output AC characteristic

●3-wired Serial

(1) 3-wired serial communication spec

Mode	PS	SEN	SCLK	SDATA
Stand-by mode	Lo	Input disable	Input disable	Input disable
Invalid communication mode	Hi	Hi	Input disable	Input disable
Write mode	Hi	Lo	SDATA latch in a rising edge	Data latch

* Input SCLK=Lo when $V_{CC} > V_{UVLO1VCC}$ or the time between start up (PS=Lo to Hi) and 3-wired serial communication (T_{EN}).

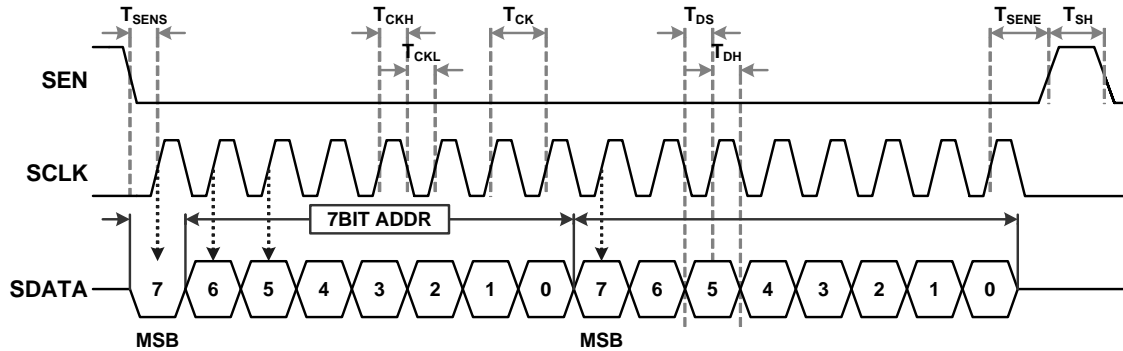

Figure 21. 3-wired serial communication

Item	Symbol	Min.	Unit
SCLK period	T_{CK}	200	ns
SCLK high pulse width	T_{CKH}	80	ns
SCLK low pulse width	T_{CKL}	80	ns
SEN START set up time	T_{SENS}	120	ns
SEN END set up time	T_{SENE}	120	ns
STROBE high time	T_{SH}	300	ns
DATA set up time (DATA of from SCLK falling to rising)	T_{DS}	80	ns
DATA hold time (DATA of from SCLK rising to falling)	T_{DH}	80	ns

(2) Register map

ADDR	W6	W5	W4	W3	W2	W1	W0	D7	D6	D5	D4	D3	D2	D1	D0
0	0	0	0	0	0	0	0	STATE SET	STATE SEL[2]	STATE SEL[1]	STATE SEL[0]	CLCANCEL	MODE	LSET	VPU
1	0	0	0	0	0	0	1	PON	NON[1]	NON[0]	VPSET [4]	VPSET [3]	VPSET [2]	VPSET [1]	VPSET [0]
2	0	0	0	0	0	1	0	AMP OVP	TEST	TR	TEST	SSSET [3]	SSSET [2]	SSSET [1]	SSSET [0]
3	0	0	0	0	0	1	1	TEST	TEST	TEST	TEST	TEST	TEST	TEST	TEST
4	0	0	0	0	1	0	0	TEST	TEST	TEST	TEST	TEST	TEST	TEST	TEST
5	0	0	0	0	1	0	1	TEST	TEST	PGFIL_	TEST	TEST	TEST	TEST	TEST

* All value of default value is 0. Stand-by condition (PS=Lo) or $V_{CC} < V_{UVLO1VCC}$ condition does reset the data as the default And all bits are set as 0.

* TEST Bits and other than address 0 to 2 should be set as 0(default) anytime.

(3) Serial register address use list

Address	Use
0	Boost start signal, Logic output signal setting, H-bridge output logic setting, STATE terminal output cl invalidity signal, STATE terminal output internal select signal setting, STATE terminal output set signal
1	Boost voltage setting, SWO switching speed setting
2	Soft start/Soft change setting, AMPOUT over voltage protection enable, Through rate control setting
3	TEST
4	TEST
5	Power good filter enable signal

(4) Serial register bit function list

Name	Function	Name	Function
VPU	Boost function start signal	LSET	Logic output voltage setting
MODE	H-bridge output logic setting	CLCANCEL	STATE terminal output c l invalid signal
STATESEL[2:0]	STATE terminal internal output signal select	STATESET	STATE terminal output setting signal
VPSET[4:0]	Boost circuit voltage setting	PON、NON[1:0]	SWO switching speed setting
SSSET[3:0]	Soft start / soft change setting	TR	Through rate control setting
AMPOVP	AMPOUT over voltage protection enable	PGFIL_	Power good filter enable signal
TEST	TEST data	-	-

● Power Dissipation

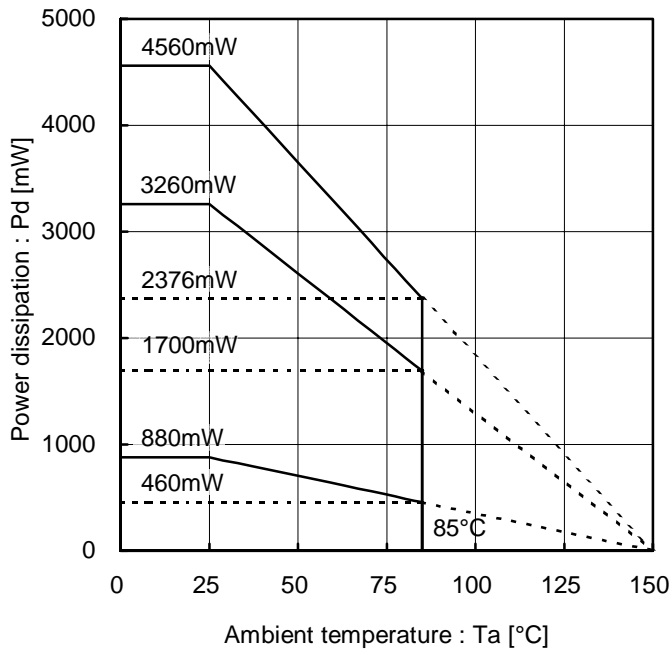

Figure 22. Package heat reduction characteristic

● I/O Equivalence Circuits

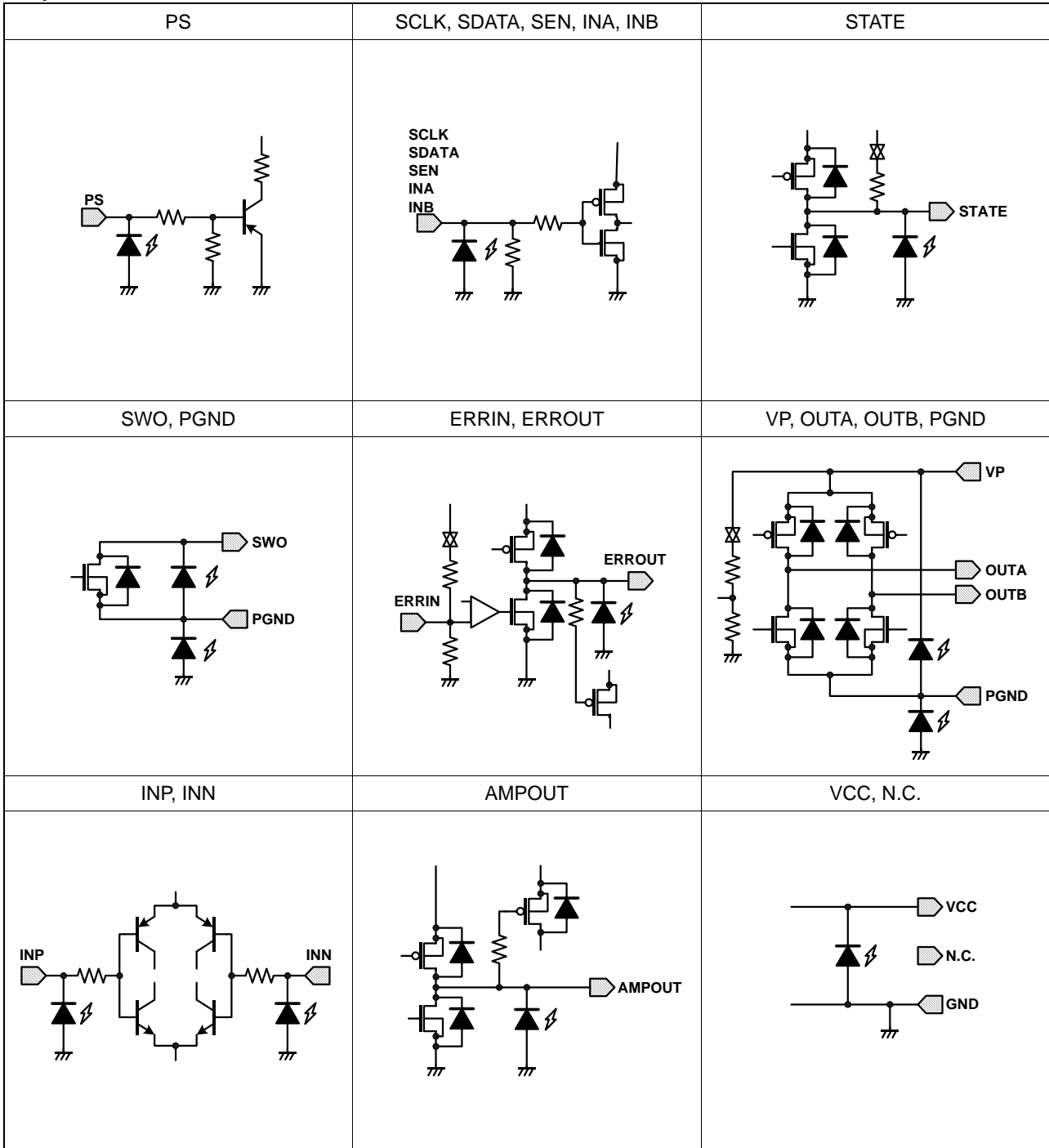

Figure 23. I/O equivalence circuit

●Operational Notes

- 1) Absolute maximum ratings
Use of the IC in excess of absolute maximum ratings such as the applied voltage or operating temperature range may result in IC damage. Assumptions should not be made regarding the state of the IC (short mode or open mode) when such damage is suffered. The implementation of a physical safety measure such as a fuse should be considered when use of the IC in a special mode where the absolute maximum ratings may be exceeded is anticipated.
- 2) Power supply pins and lines
None of the VP line for the H-bridges is internally connected to the VCC power supply line, which is only for the control logic or analog circuit. Therefore, the VP and VCC lines can be driven at different voltages. Although these lines can be connected to a common power supply, do not open the power supply pin but connect it to the power supply externally. Regenerated current may flow as a result of the motor's back electromotive force. Insert capacitors between the power supply and ground pins to serve as a route for regenerated current. Determine the capacitance in full consideration of all the characteristics of the electrolytic capacitor, because the electrolytic capacitor may lose some capacitance at low temperatures. If the connected power supply does not have sufficient current absorption capacity, regenerative current will cause the voltage on the power supply line to rise, which combined with the product and its peripheral circuitry may exceed the absolute maximum ratings. It is recommended to implement a physical safety measure such as the insertion of a voltage clamp diode between the power supply and ground pins.
For this IC with several power supplies and a part consists of the CMOS block, it is possible that rush current may flow instantaneously due to the internal powering sequence and delays, and to the unstable internal logic, respectively. Therefore, give special consideration to power coupling capacitance, width of power and ground wirings, and routing of wiring.
- 3) Ground pins and lines
Ensure a minimum GND pin potential in all operating conditions. Make sure that no pins are at a voltage below the GND at any time, regardless of whether it is a transient signal or not.
When using both small signal GND and large current PGND patterns, it is recommended to isolate the two ground patterns, placing a single ground point at the application's reference point so that the pattern wiring resistance and voltage variations caused by large currents do not cause variations in the small signal ground voltage. Be careful not to change the GND wiring pattern of any external components, either.
The power supply and ground lines must be as short and thick as possible to reduce line impedance.
- 4) Thermal design
Use a thermal design that allows for a sufficient margin in light of the power dissipation (Pd) in actual operating conditions.
- 5) Actions in strong magnetic field
Use caution when using the IC in the presence of a strong magnetic field as doing so may cause the IC to malfunction.
- 6) ASO
When using the IC, set the output transistor for the motor so that it does not exceed absolute maximum ratings or ASO.
- 7) Thermal shutdown circuit
This IC incorporates a TSD (thermal shutdown) circuit. If the temperature of the chip reaches the following temperature, the motor coil output will be opened. The TSD circuit is designed only to shut the IC off to prevent runaway thermal operation. It is not designed to protect the IC or guarantee its operation. Do not continue to use the IC after operating this circuit or use the IC in an environment where the operation of this circuit is assumed.

TSD ON temperature [°C] (Typ.)	Hysteresis temperature [°C] (Typ.)
175	20
- 8) After releasing Under Voltage Locked Out (UVLO) or Thermal Shut Down (TSD)
When UVLO, TSD is released, it returns normal operation after 100µs (max).
- 9) VBAT external power supply
This IC is not equipped with terminal of VBAT, and operate even the VBAT external power supply is lower than 4V (minimum VP operation voltage). Give consideration that if VBAT external power supply is low and VP setting voltage is high or load is large, may cause an overcurrent flowing through SWO terminal, and may enable OCP, TSD, etc. In addition, if the VBAT external power supply has changed during the boost operation (ex. VBAT=HiZ), because of boosting VP to setting voltage without working soft start / soft change, may cause overcurrent flowing through SWO terminal. If VBAT external power supply is changing, stop boost operation by setting PS=0V or VPU=1'b0, then set the soft start function after VBAT power supply voltage is stable.
- 10) N.C. pin
Always keep N.C. pin open.

11) Application example

The application circuit is recommended for use. Make sure to confirm the adequacy of the characteristics. When using the circuit with changes to the external circuit constants, make sure to leave an adequate margin for external components including static and transitional characteristics as well as dispersion of the IC.

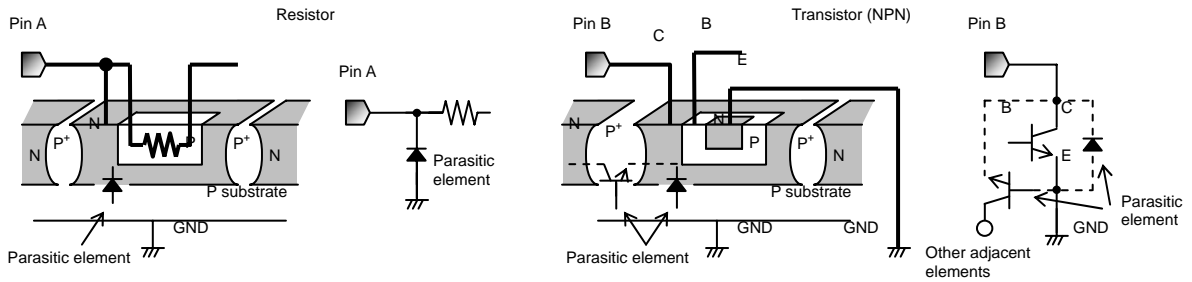

Figure 24. Example of Simple IC Architecture

Status of this document

The Japanese version of this document is formal specification. A customer may use this translation version only for a reference to help reading the formal version.

If there are any differences in translation version of this document formal version takes priority

●Physical Dimension, Tape and Reel Information

VQFN028V5050

(Unit : mm)

<Tape and Reel information>

Tape	Embossed carrier tape
Quantity	2500pcs
Direction of feed	E2 (The direction is the 1pin of product is at the upper left when you hold reel on the left hand and you pull out the tape on the right hand)

*Order quantity needs to be multiple of the minimum quantity.

●Marking Diagram

VQFN028V5050 (TOP VIEW)

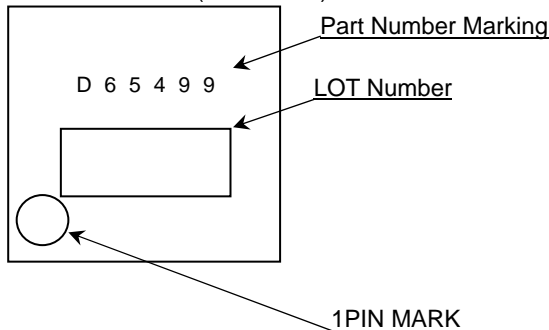

●Revision History

Date	Revision	Changes
3.Aug.2012	001	New Release

Notice

Precaution on using ROHM Products

- Our Products are designed and manufactured for application in ordinary electronic equipments (such as AV equipment, OA equipment, telecommunication equipment, home electronic appliances, amusement equipment, etc.). If you intend to use our Products in devices requiring extremely high reliability (such as medical equipment ^(Note 1), transport equipment, traffic equipment, aircraft/spacecraft, nuclear power controllers, fuel controllers, car equipment including car accessories, safety devices, etc.) and whose malfunction or failure may cause loss of human life, bodily injury or serious damage to property ("Specific Applications"), please consult with the ROHM sales representative in advance. Unless otherwise agreed in writing by ROHM in advance, ROHM shall not be in any way responsible or liable for any damages, expenses or losses incurred by you or third parties arising from the use of any ROHM's Products for Specific Applications.

(Note1) Medical Equipment Classification of the Specific Applications

JAPAN	USA	EU	CHINA
CLASS III	CLASS III	CLASS II b	CLASS III
CLASS IV		CLASS III	

- ROHM designs and manufactures its Products subject to strict quality control system. However, semiconductor products can fail or malfunction at a certain rate. Please be sure to implement, at your own responsibilities, adequate safety measures including but not limited to fail-safe design against the physical injury, damage to any property, which a failure or malfunction of our Products may cause. The following are examples of safety measures:
 - Installation of protection circuits or other protective devices to improve system safety
 - Installation of redundant circuits to reduce the impact of single or multiple circuit failure
- Our Products are designed and manufactured for use under standard conditions and not under any special or extraordinary environments or conditions, as exemplified below. Accordingly, ROHM shall not be in any way responsible or liable for any damages, expenses or losses arising from the use of any ROHM's Products under any special or extraordinary environments or conditions. If you intend to use our Products under any special or extraordinary environments or conditions (as exemplified below), your independent verification and confirmation of product performance, reliability, etc. prior to use, must be necessary:
 - Use of our Products in any types of liquid, including water, oils, chemicals, and organic solvents
 - Use of our Products outdoors or in places where the Products are exposed to direct sunlight or dust
 - Use of our Products in places where the Products are exposed to sea wind or corrosive gases, including Cl₂, H₂S, NH₃, SO₂, and NO₂
 - Use of our Products in places where the Products are exposed to static electricity or electromagnetic waves
 - Use of our Products in proximity to heat-producing components, plastic cords, or other flammable items
 - Sealing or coating our Products with resin or other coating materials
 - Use of our Products without cleaning residue of flux (even if you use no-clean type fluxes, cleaning residue of flux is recommended); or Washing our Products by using water or water-soluble cleaning agents for cleaning residue after soldering
 - Use of the Products in places subject to dew condensation
- The Products are not subject to radiation-proof design.
- Please verify and confirm characteristics of the final or mounted products in using the Products.
- In particular, if a transient load (a large amount of load applied in a short period of time, such as pulse. is applied, confirmation of performance characteristics after on-board mounting is strongly recommended. Avoid applying power exceeding normal rated power; exceeding the power rating under steady-state loading condition may negatively affect product performance and reliability.
- De-rate Power Dissipation (Pd) depending on Ambient temperature (Ta). When used in sealed area, confirm the actual ambient temperature.
- Confirm that operation temperature is within the specified range described in the product specification.
- ROHM shall not be in any way responsible or liable for failure induced under deviant condition from what is defined in this document.

Precaution for Mounting / Circuit board design

- When a highly active halogenous (chlorine, bromine, etc.) flux is used, the residue of flux may negatively affect product performance and reliability.
- In principle, the reflow soldering method must be used; if flow soldering method is preferred, please consult with the ROHM representative in advance.

For details, please refer to ROHM Mounting specification

Precautions Regarding Application Examples and External Circuits

1. If change is made to the constant of an external circuit, please allow a sufficient margin considering variations of the characteristics of the Products and external components, including transient characteristics, as well as static characteristics.
2. You agree that application notes, reference designs, and associated data and information contained in this document are presented only as guidance for Products use. Therefore, in case you use such information, you are solely responsible for it and you must exercise your own independent verification and judgment in the use of such information contained in this document. ROHM shall not be in any way responsible or liable for any damages, expenses or losses incurred by you or third parties arising from the use of such information.

Precaution for Electrostatic

This Product is electrostatic sensitive product, which may be damaged due to electrostatic discharge. Please take proper caution in your manufacturing process and storage so that voltage exceeding the Products maximum rating will not be applied to Products. Please take special care under dry condition (e.g. Grounding of human body / equipment / solder iron, isolation from charged objects, setting of Ionizer, friction prevention and temperature / humidity control).

Precaution for Storage / Transportation

1. Product performance and soldered connections may deteriorate if the Products are stored in the places where:
 - [a] the Products are exposed to sea winds or corrosive gases, including Cl₂, H₂S, NH₃, SO₂, and NO₂
 - [b] the temperature or humidity exceeds those recommended by ROHM
 - [c] the Products are exposed to direct sunshine or condensation
 - [d] the Products are exposed to high Electrostatic
2. Even under ROHM recommended storage condition, solderability of products out of recommended storage time period may be degraded. It is strongly recommended to confirm solderability before using Products of which storage time is exceeding the recommended storage time period.
3. Store / transport cartons in the correct direction, which is indicated on a carton with a symbol. Otherwise bent leads may occur due to excessive stress applied when dropping of a carton.
4. Use Products within the specified time after opening a humidity barrier bag. Baking is required before using Products of which storage time is exceeding the recommended storage time period.

Precaution for Product Label

QR code printed on ROHM Products label is for ROHM's internal use only.

Precaution for Disposition

When disposing Products please dispose them properly using an authorized industry waste company.

Precaution for Foreign Exchange and Foreign Trade act

Since our Products might fall under controlled goods prescribed by the applicable foreign exchange and foreign trade act, please consult with ROHM representative in case of export.

Precaution Regarding Intellectual Property Rights

1. All information and data including but not limited to application example contained in this document is for reference only. ROHM does not warrant that foregoing information or data will not infringe any intellectual property rights or any other rights of any third party regarding such information or data. ROHM shall not be in any way responsible or liable for infringement of any intellectual property rights or other damages arising from use of such information or data.:
2. No license, expressly or implied, is granted hereby under any intellectual property rights or other rights of ROHM or any third parties with respect to the information contained in this document.

Other Precaution

1. This document may not be reprinted or reproduced, in whole or in part, without prior written consent of ROHM.
2. The Products may not be disassembled, converted, modified, reproduced or otherwise changed without prior written consent of ROHM.
3. In no event shall you use in any way whatsoever the Products and the related technical information contained in the Products or this document for any military purposes, including but not limited to, the development of mass-destruction weapons.
4. The proper names of companies or products described in this document are trademarks or registered trademarks of ROHM, its affiliated companies or third parties.

General Precaution

1. Before you use our Products, you are requested to carefully read this document and fully understand its contents. ROHM shall not be in any way responsible or liable for failure, malfunction or accident arising from the use of any ROHM's Products against warning, caution or note contained in this document.
2. All information contained in this document is current as of the issuing date and subject to change without any prior notice. Before purchasing or using ROHM's Products, please confirm the latest information with a ROHM sales representative.
3. The information contained in this document is provided on an "as is" basis and ROHM does not warrant that all information contained in this document is accurate and/or error-free. ROHM shall not be in any way responsible or liable for any damages, expenses or losses incurred by you or third parties resulting from inaccuracy or errors of or concerning such information.

X-ON Electronics

Largest Supplier of Electrical and Electronic Components

Click to view similar products for [Motor/Motion/Ignition Controllers & Drivers](#) category:

Click to view products by [ROHM](#) manufacturer:

Other Similar products are found below :

[FSB50550TB2](#) [FSBF15CH60BTH](#) [MSVCPM2-63-12](#) [MSVGW45-14-2](#) [MSVGW54-14-3](#) [MSVGW54-14-5](#) [NTE7043](#) [LA6565VR-TLM-E](#)
[LB11650-E](#) [LB1837M-TLM-E](#) [LB1845DAZ-XE](#) [LC898300XA-MH](#) [SS30-TE-L-E](#) [26700](#) [LV8281VR-TLM-H](#) [BA5839FP-E2](#) [IRAM236-1067A](#) [LA6584JA-AH](#) [LB11847L-E](#) [NCV70501DW002R2G](#) [AH293-PL-B](#) [STK672-630CN-E](#) [TND315S-TL-2H](#) [FNA23060](#) [FSB50250AB](#)
[FNA41060](#) [MSVB54](#) [MSVBTC50E](#) [MSVCPM3-54-12](#) [MSVCPM3-63-12](#) [MSVCPM4-63-12](#) [MSVTA120](#) [FSB50550AB](#)
[NCV70501DW002G](#) [LC898301XA-MH](#) [LV8413GP-TE-L-E](#) [MSVGW45-14-3](#) [MSVGW45-14-4](#) [MSVGW45-14-5](#) [MSVGW54-14-4](#)
[STK984-091A-E](#) [MP6519GQ-Z](#) [LB11651-E](#) [IRSM515-025DA4](#) [LV8127T-TLM-H](#) [MC33812EKR2](#) [NCP81382MNTXG](#) [TDA21801](#)
[LB11851FA-BH](#) [NCV70627DQ001R2G](#)