

Power Management for Mobile Phones

Power Management IC for Battery Charger

BD6550G



●Description

The BD6550G is a compact constant-current and constant-voltage controller, incorporating built-in high-precision reference voltage and two OPamp circuits.

It is ideal for use in secondary-side controllers for battery chargers.

●Features

- 1) Constant-current and constant-voltage controller
- 2) Power supply voltage range: 2.5 V to 12 V
- 3) High-precision reference voltage: 1.21 V \pm 1%
- 4) Current detection voltage precision: \pm 2%
- 5) Package: SSOP6

●Applications

The BD6550G is designed for use in secondary-side controllers for battery chargers and similar devices.

●Absolute maximum ratings (Ta = 25°C)

Parameter	Symbol	Limit	Unit
Power supply voltage	VMAX	-0.3 to 14	V
ICT pin maximum voltage	VICTMAX	-0.3 to VCC	V
Power dissipation	Pd	675 *1	mW
Operating temperature range	Topr	0 to +85	°C
Storage temperature range	Tstg	-55 to +150	°C

*1: Reduced by 5.4 mW/°C over 25°C, when mounted on a PCB (70 mm \times 70 mm \times 1.6 mm, glass epoxy).

●Recommended operating ranges

Parameter	Symbol	Limit	Unit
Power supply voltage	VCC	2.5 to 12	V

● **Electrical Characteristics**

(Unless otherwise specified, $T_a = 25^\circ\text{C}$, $V_{cc} = +5\text{ V}$)

Parameter	Symbol	Limit			Unit	Conditions
		Min.	Typ.	Max.		
[Total current consumption]						
Total supply current - not including output sink current	ICC	-	0.9	2	mA	
[Voltage control loop]						
Transconductance gain (VCT). Sink current only	GMV	1	4.0	-	mA/mV	*1
Voltage control loop reference at 1.5 mA sinking current	VREF	1.198	1.21	1.222	V	$T_a = 25^\circ\text{C}$
		1.186	1.21	1.234		$0 < T_a < 85^\circ\text{C}$ *1
Input bias current (VCT)	Ibv	-	50	-	nA	*1
[Current control loop]						
Transconductance gain (ICT). Sink current only	GMI	1.5	4.0	-	mA/mV	*1
Current control loop reference at 2.5 mA sinking current	VSE	196	200	204	mV	$T_a = 25^\circ\text{C}$
		192	200	208		$0 < T_a < 85^\circ\text{C}$ *1
Current out of pin ICT at -200 mV	Ibi	-	25	-	μA	
[Output stage]						
Low output voltage at 10 mA sinking current	VOL	-	200	-	mV	$VSE = 0\text{ V}$, $ICT = -0.3\text{ V}$
Output short circuit current, output to V_{cc} , sink current only	IOS	-	20	50	mA	$OUT = V_{CC}$, $VSE = 0\text{ V}$, $ICT = -0.3\text{ V}$

⊙ This product is not designed for protection against radioactive rays.

*1: Design guarantee.

● **Test circuit**

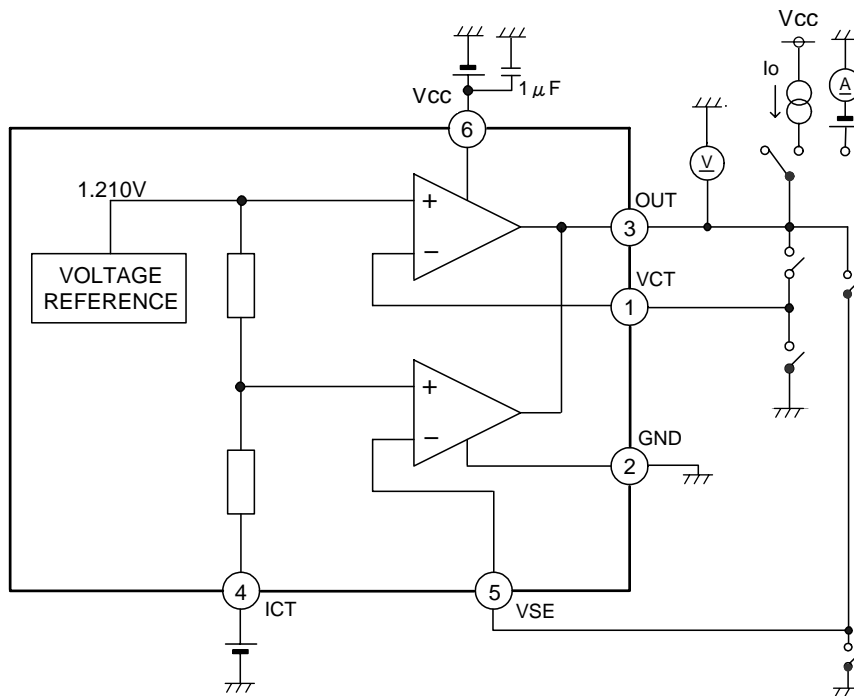

Fig. 1

●Reference data

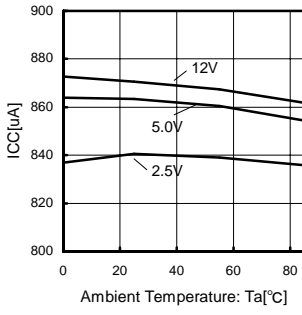

Fig. 2 Circuit Current vs. Temperature

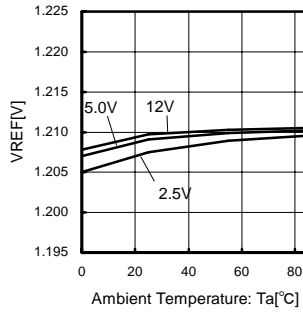

Fig. 3 Voltage Control Reference Voltage vs. Temperature

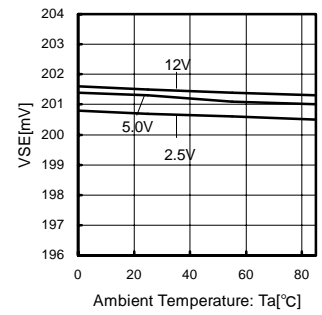

Fig. 4 Current Control Reference Voltage vs. Temperature

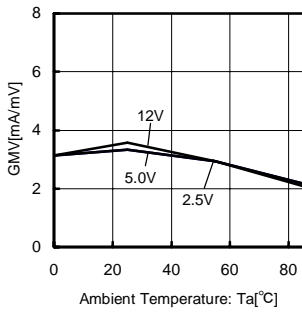

Fig. 5 Voltage Control Amplifier: GM vs. Temperature

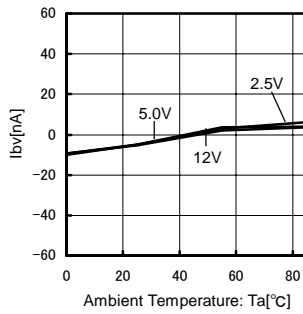

Fig. 6 Input Bias Current vs. Temperature

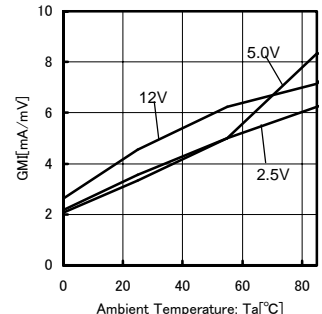

Fig. 7 Current Control Amplifier: GM vs. Temperature

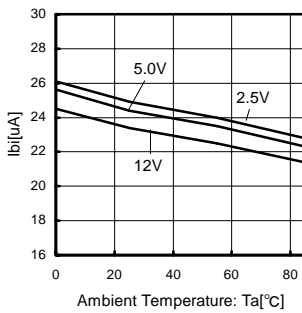

Fig. 8 ICT Pin Source Current vs. Temperature

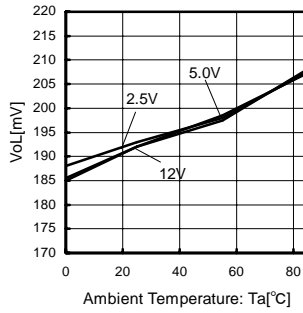

Fig. 9 10 mA Sink Output Voltage vs. Temperature

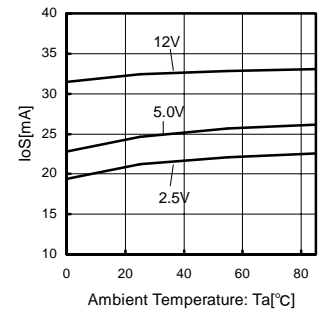

Fig. 10 Output Short Circuit Current vs. Temperature

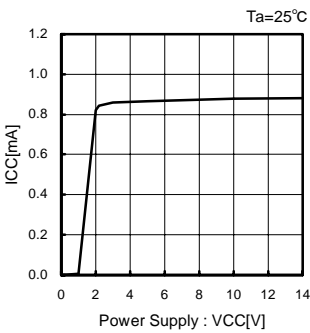

Fig. 11 Circuit Current vs. Power Supply voltage

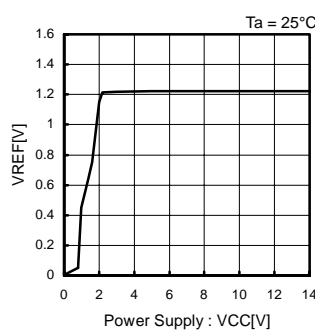

Fig. 12 Voltage Control Reference Voltage vs. Power Supply voltage

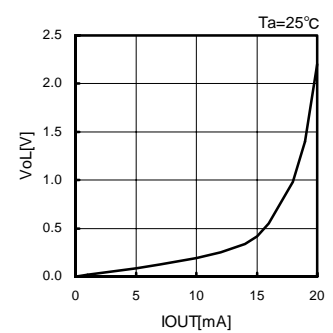

Fig. 13 Output Voltage vs. Sink Current

●Block diagram

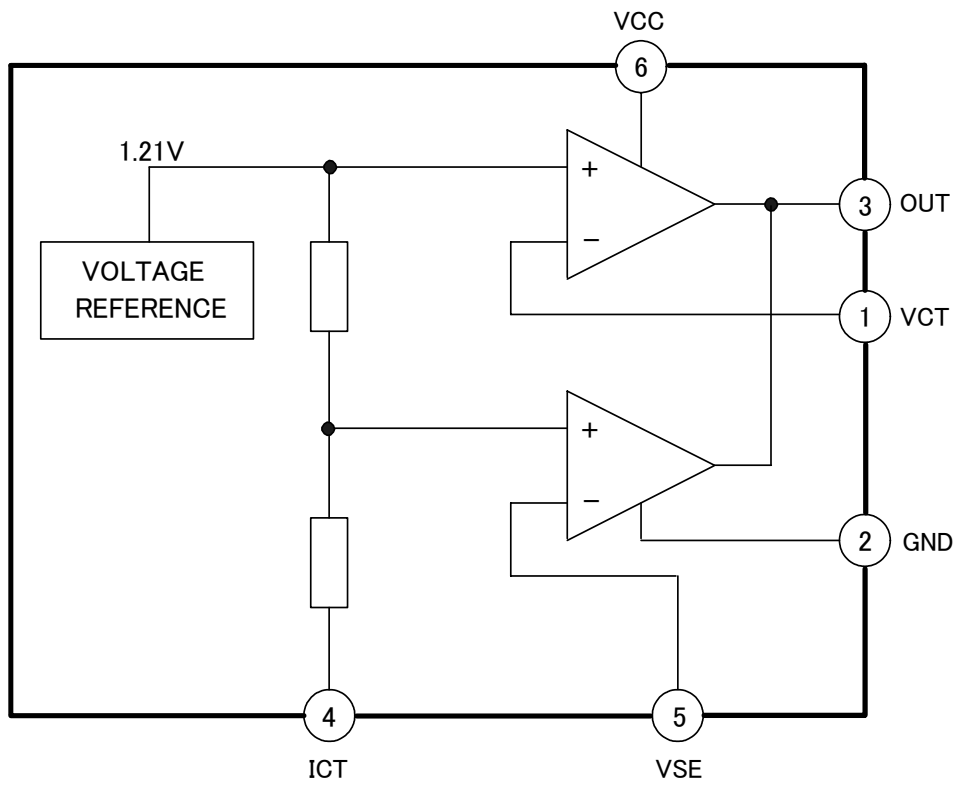

Fig.14

●Pin descriptions

No.	Pin name	Type	Function
1	VCT	Analog sense pin	Input pin of the voltage control loop
2	GND	Power supply pin	Ground line. 0 V reference for all voltages
3	OUT	Sink current output pin	Output pin. Sinking current only
4	ICT	Analog sense pin	Input pin of the current control loop (+)
5	VSE	Analog sense pin	Input pin of the current control loop (-)
6	VCC	Power supply pin	Positive power supply line

●I/O Equivalent circuits

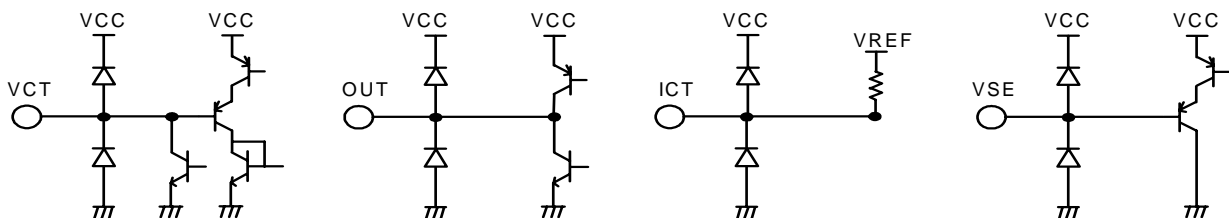

Fig. 15

● Application circuit example

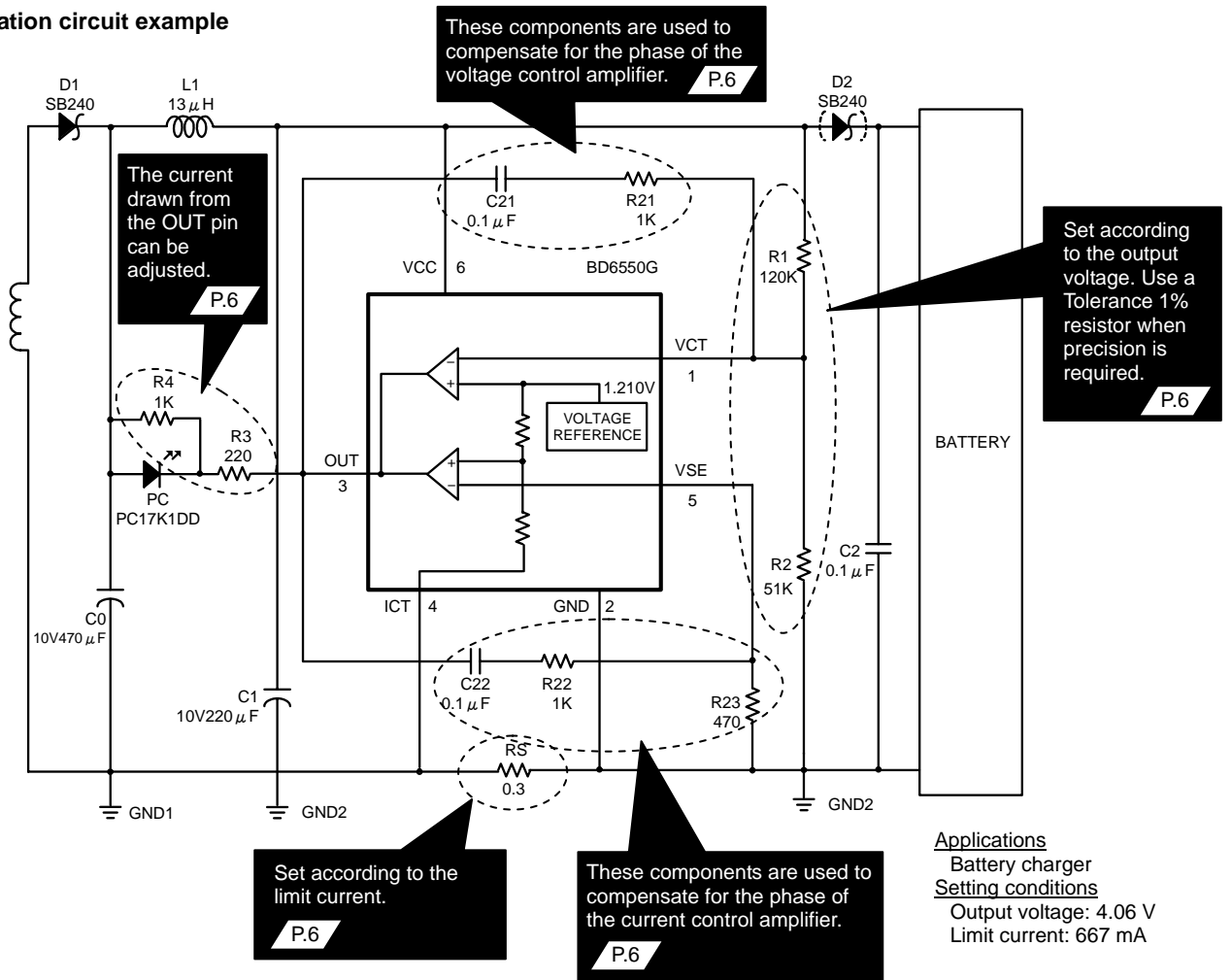

Fig. 16

$$V_{OUT} = V_{REF} \times (R1+R2) / R2 [V] \quad (\text{without diode D2})$$

$$\text{CURRENT LIMIT: } I_L = V_{SE} / R_S [A]$$

List of recommended components

Symbol	Part number	Constant
C0	UD Series (Nichicon)	220 μF to 1000 μF
C1	UD Series (Nichicon)	100 μF to 680 μF
C2	MCH182CNxxx (ROHM)	0.47 μF to 2.2 μF
C21	MCH182CN104 (ROHM)	0.1 μF
C22	MCH182CN104 (ROHM)	0.1 μF
L1	-	13 μH (I _{dc} : 2A)
R1	MCR03 (ROHM)	120 k (Tolerance F)
R2	MCR03 (ROHM)	51 k (Tolerance F)
R3	MCR03 (ROHM)	100 to 470
R4	MCR03 (ROHM)	1 k
R21	MCR03 (ROHM)	1 k
R22	MCR03 (ROHM)	1 k
R23	MCR03 (ROHM)	470
RS	MCR25 (ROHM)	0.3 (Tolerance F)
D1	SB240	-
D2	SB240	-
PC	PC17K1DD (KODENSHI)	-

○ Precautions:

Although ROHM is confident that the example application circuit reflects the best possible recommendations, be sure to verify circuit characteristics for your particular application.

Modification of constants for other externally connected circuits may cause variations in both static and transient characteristics for external components as well as this Rohm IC. Allow for sufficient margins when determining circuit constants.

●Operating principles and supplemental information

1. Current and voltage control

(1-1) Voltage control

Voltage feedback consists of an operational amplifier, resistors (R1, R2), and a photocoupler (PC), that is directly connected to output. Equation (A) illustrates the relationship between R1 and R2.

$$R2 = R1 \times VREF / (VOUT - VREF) \quad \text{Equation (A)}$$

In the above equation, VOUT represents the output voltage. While VOUT can be set freely with R1 and R2, it is limited to the VCC operating range for applications such as that illustrated in Figure 16, where the VCC pin and system output are common.

The R1 and R2 resistors must have high resistance values in order to prevent discharge from the load side of the circuit. In the application circuit illustrated in Fig. 16, it is desirable that the total resistance value for resistors R1 and R2 be at least 100 kΩ. However, because the VCT pin has a bias current of 50 nA (typ.), it is also recommended that R2 be less than 1.2 MΩ to avoid any error in the resistance ratio of R1 and R2.

Reference values are provided below.

$$R2 = 51 \text{ k}\Omega, Vout = 4.06 \text{ V}, Vref = 1.210 \text{ V}, R1 = 120 \text{ k}\Omega$$

It is necessary to replace VOUT with VOUT + VDROP in equation (A) when inserting the low-drop diode D2, between the load and the voltage control resistor. This is to prevent the load current from passing through the resistors.

(1-2) Current control

Current feedback consists of an operational amplifier, RS resistor, and a photocoupler.

Equations (B) and (C) provide the control equation.

$$RS \times IL = VSE \quad \text{Equation (B)}$$

$$RS = VSE / IL \quad \text{Equation (C)}$$

In these above equations, IL represents the limit current, and VSE represents the current control feedback detection voltage. Using reference values, yields a RS value of 200 mΩ when IL = 1A and VSE = -200 mV.

Be sure to consider the limit current that will become the maximum load when determining the RS value.

$$PI = VSE \times IL \quad \text{Equation (D)}$$

Using the example above, a PI of 200 mW results when IL = 1A and VSE = 200 mV.

As a result, use current detection 1/4 watt and 1/2 watt resistors for most adapters and battery charger applications.

2. Phase compensation

Phase compensation for the voltage control amplifier and current control amplifier is possible by directly connecting output pins and inverted input pins to external components. When selecting external components, refer to the open loop characteristics for both control amplifiers illustrated in Fig. 17 and Fig. 18. Be sure to consider variations in external components and this Rohm IC, including both static and transient characteristics, to allow for sufficient margins.

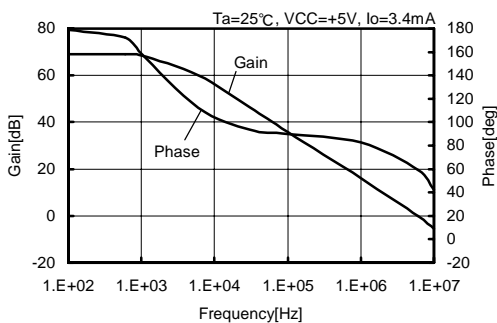

Fig. 17 Voltage Control Amplifier:
Frequency Characteristics of Gain, Phase

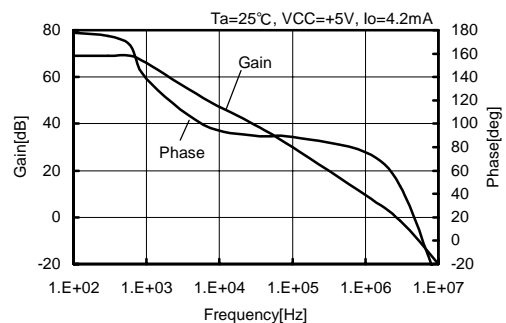

Fig. 18 Current Control Amplifier:
Frequency Characteristics of Gain, Phase

3. OUT pin

The current drawn from the OUT pin can be adjusted with the R3 and R4 resistors. The Vref value assumes a current draw of 1.5 mA, so it is recommended to use the resistors noted in this document.

● **Operation notes**

1. Absolute maximum ratings

An excess in the absolute maximum ratings, such as supply voltage, temperature range of operating conditions, etc., can break down the devices, thus making impossible to identify breaking mode, such as a short circuit or an open circuit. If any over rated values will expect to exceed the absolute maximum ratings, consider adding circuit protection devices, such as fuses.

2. GND voltage

The potential of GND pin must be minimum potential in all operating conditions. As an exception, the circuit design allows voltage up to -0.3V to be applied to the ICT pin.

3. Thermal design

Use a thermal design that allows for a sufficient margin in light of the power dissipation (Pd) in actual operating conditions.

4. Inter-pin shorts and mounting errors

Use caution when positioning the IC for mounting on printed circuit boards. The IC may be damaged if there is any connection error or if pins are shorted together.

5. Actions in strong electromagnetic field

Use caution when using the IC in the presence of a strong electromagnetic field as doing so may cause the IC to malfunction.

6. Power line impedance

Power supply and ground wiring pattern should be as shot and thick as possible to lower mutual impedance and minimize ripple. For ripple rejection, add an inductance and capacitance network.

7. Regarding input pin of the IC

This monolithic IC contains P+ isolation and P substrate layers between adjacent elements in order to keep them isolated. P-N junctions are formed at the intersection of these P layers with the N layers of other elements, creating a parasitic diode or transistor. For example, the relation between each potential is as follows:

When $GND > Pin A$ and $GND > Pin B$, the P-N junction operates as a parasitic diode.

When $GND > Pin B$, the P-N junction operates as a parasitic transistor.

Parasitic diodes can occur inevitable in the structure of the IC. The operation of parasitic diodes can result in mutual interference among circuits, operational faults, or physical damage. Accordingly, methods by which parasitic diodes operate, such as applying a voltage that is lower than the GND (P substrate) voltage to an input pin, should not be used.

Although the circuit design allows voltages up to -0.3 V to be applied to the ICT pin, voltages lower than this may cause the behavior described above. Use caution when designing the circuit.

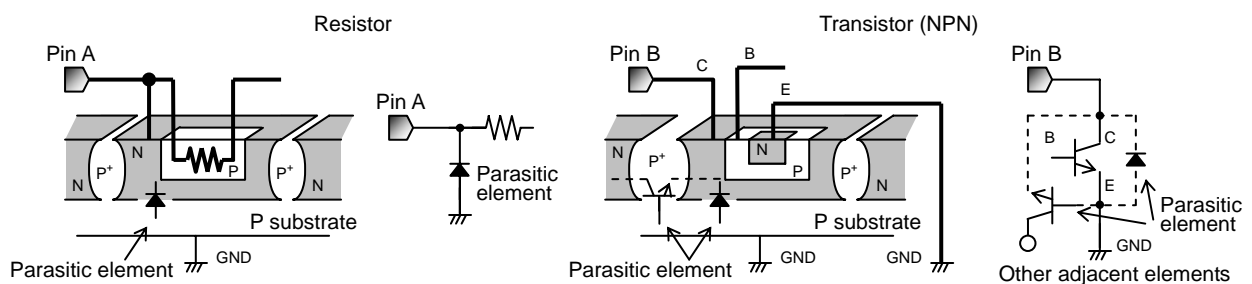
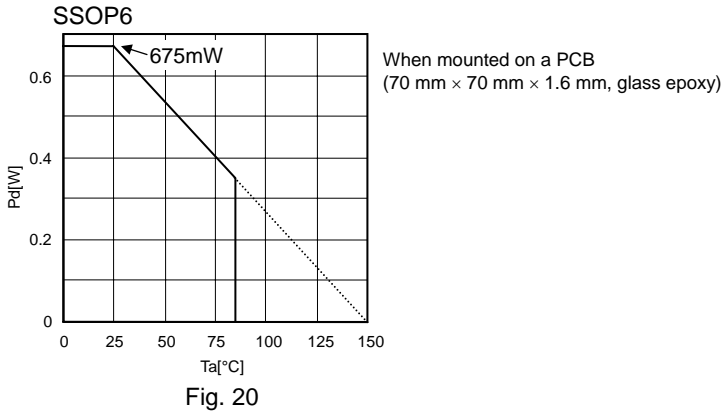
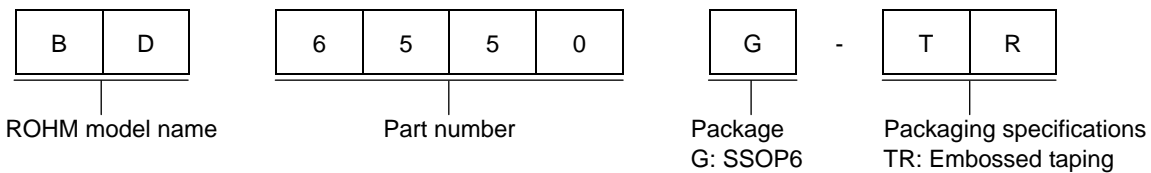

Fig. 19 Example of IC structure

● Power dissipation reduction



● Selecting a Model Name When Ordering



SSOP6

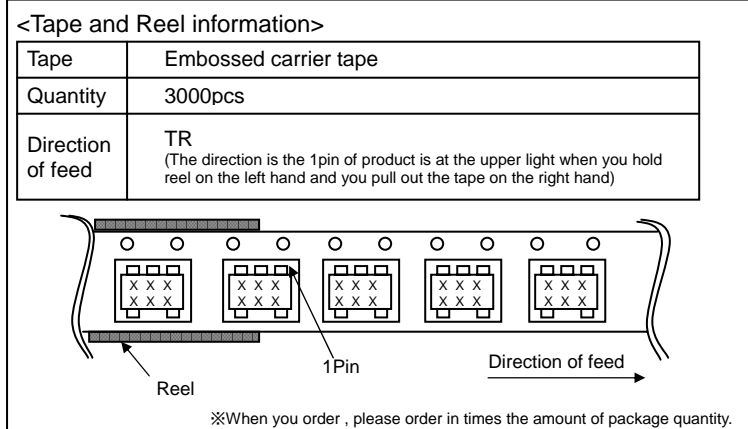
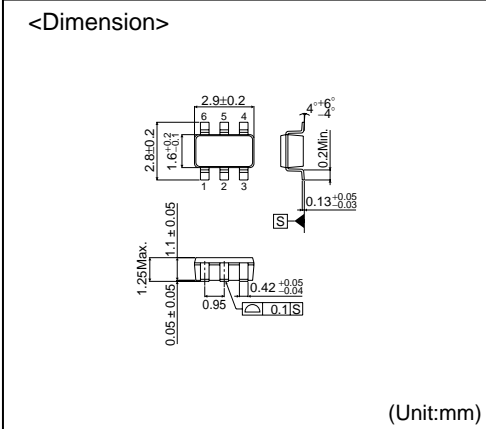

- The contents described herein are correct as of October, 2005
- The contents described herein are subject to change without notice. For updates of the latest information, please contact and confirm with ROHM CO.,LTD.
- Any part of this application note must not be duplicated or copied without our permission.
- Application circuit diagrams and circuit constants contained herein are shown as examples of standard use and operation. Please pay careful attention to the peripheral conditions when designing circuits and deciding upon circuit constants in the set.
- Any data, including, but not limited to application circuit diagrams and information, described herein are intended only as illustrations of such devices and not as the specifications for such devices. ROHM CO.,LTD. disclaims any warranty that any use of such devices shall be free from infringement of any third party's intellectual property rights or other proprietary rights, and further, assumes no liability of whatsoever nature in the event of any such infringement, or arising from or connected with or related to the use of such devices.
- Upon the sale of any such devices, other than for buyer's right to use such devices itself, resell or otherwise dispose of the same, implied right or license to practice or commercially exploit any intellectual property rights or other proprietary rights owned or controlled by ROHM CO., LTD. is granted to any such buyer.
- The products described herein utilize silicon as the main material.
- The products described herein are not designed to be X ray proof.

The products listed in this catalog are designed to be used with ordinary electronic equipment or devices (such as audio visual equipment, office-automation equipment, communications devices, electrical appliances and electronic toys). Should you intend to use these products with equipment or devices which require an extremely high level of reliability and the malfunction of which would directly endanger human life (such as medical instruments, transportation equipment, aerospace machinery, nuclear-reactor controllers, fuel controllers and other safety devices), please be sure to consult with our sales representative in advance.



ROHM CO., LTD.
21, Saiin Mizosaki-cho, Ukyo-ku, Kyoto
615-8585, Japan
TEL: (075)311-2121 FAX: (075)315-0172
URL: <http://www.rohm.com>

Published by
Application Engineering Group

Contact us for further information about the products.

- Atlanta U.S.A. / ROHM ELECTRONICS ATLANTA SALES OFFICE (DIVISION OF ROHM ELE. U.S.A.,LLC)
TEL: +1(770)754-5972 FAX: +1(770)754-0691
- Dallas U.S.A. / ROHM ELECTRONICS DALLAS SALES OFFICE (DIVISION OF ROHM ELE. U.S.A.,LLC)
TEL: +1(972)312-8818 FAX: +1(972)312-0330
- San Diego U.S.A. / ROHM ELECTRONICS SAN DIEGO SALES OFFICE (DIVISION OF ROHM ELE. U.S.A.,LLC)
TEL: +1(659)625-3630 FAX: +1(659)625-3670
- Germany / ROHM ELECTRONICS GMBH (GERMANY)
TEL: +49(2154)9210 FAX: +49(2154)921400
- United Kingdom / ROHM ELECTRONICS GMBH (UK)
TEL: +44(0)1908-306700 FAX: +44(0)1908-235788
- France / ROHM ELECTRONICS GMBH (FRANCE)
TEL: +33(0)1 56 97 30 60 FAX: +33(0)1 56 97 30 80
- Hong Kong China / ROHM ELECTRONICS (H.K.) CO., LTD.
TEL: +852(2)7406262 FAX: +852(2)375-8971
- Shanghai China / ROHM ELECTRONICS (SHANGHAI) CO., LTD.
TEL: +86(21)6279-2727 FAX: +86(21)6247-2066
- Dalian China / ROHM ELECTRONICS TRADING (DALIAN) CO., LTD.
TEL: +86(411)8230-8549 FAX: +86(411)8230-8537

- Beijing China / BEIJING REPRESENTATIVE OFFICE
TEL: +86(10)8525-2483 FAX: +86(10)8525-2489
- Taiwan / ROHM ELECTRONICS TAIWAN CO., LTD.
TEL: +886(2)2500-6936 FAX: +886(2)2503-2869
- Korea / ROHM ELECTRONICS KOREA CORPORATION
TEL: +82(2)8182-700 FAX: +82(2)8182-715
- Singapore / ROHM ELECTRONICS ASIA PTE. LTD. (RES/REI)
TEL: +65-6332-2322 FAX: +65-6332-5662
- Malaysia / ROHM ELECTRONICS (MALAYSIA) SDN. BHD.
TEL: +60(3)7958-8355 FAX: +60(3)7958-8377
- Philippines / ROHM ELECTRONICS (PHILIPPINES) SALES CORPORATION
TEL: +63(2)807-6872 FAX: +63(2)809-1422
- Thailand / ROHM ELECTRONICS (THAILAND) CO., LTD.
TEL: +66(2)254-4890 FAX: +66(2)256-6334

Notes

- No technical content pages of this document may be reproduced in any form or transmitted by any means without prior permission of ROHM CO.,LTD.
- The contents described herein are subject to change without notice. The specifications for the product described in this document are for reference only. Upon actual use, therefore, please request that specifications to be separately delivered.
- Application circuit diagrams and circuit constants contained herein are shown as examples of standard use and operation. Please pay careful attention to the peripheral conditions when designing circuits and deciding upon circuit constants in the set.
- Any data, including, but not limited to application circuit diagrams information, described herein are intended only as illustrations of such devices and not as the specifications for such devices. ROHM CO.,LTD. disclaims any warranty that any use of such devices shall be free from infringement of any third party's intellectual property rights or other proprietary rights, and further, assumes no liability of whatsoever nature in the event of any such infringement, or arising from or connected with or related to the use of such devices.
- Upon the sale of any such devices, other than for buyer's right to use such devices itself, resell or otherwise dispose of the same, no express or implied right or license to practice or commercially exploit any intellectual property rights or other proprietary rights owned or controlled by
- ROHM CO., LTD. is granted to any such buyer.
- Products listed in this document are no antiradiation design.

The products listed in this document are designed to be used with ordinary electronic equipment or devices (such as audio visual equipment, office-automation equipment, communications devices, electrical appliances and electronic toys).

Should you intend to use these products with equipment or devices which require an extremely high level of reliability and the malfunction of which would directly endanger human life (such as medical instruments, transportation equipment, aerospace machinery, nuclear-reactor controllers, fuel controllers and other safety devices), please be sure to consult with our sales representative in advance.

It is our top priority to supply products with the utmost quality and reliability. However, there is always a chance of failure due to unexpected factors. Therefore, please take into account the derating characteristics and allow for sufficient safety features, such as extra margin, anti-flammability, and fail-safe measures when designing in order to prevent possible accidents that may result in bodily harm or fire caused by component failure. ROHM cannot be held responsible for any damages arising from the use of the products under conditions out of the range of the specifications or due to non-compliance with the NOTES specified in this catalog.

Thank you for your accessing to ROHM product informations.

More detail product informations and catalogs are available, please contact your nearest sales office.

ROHM Customer Support System

THE AMERICAS / EUROPE / ASIA / JAPAN

www.rohm.com

Contact us : webmaster@rohm.co.jp

X-ON Electronics

Largest Supplier of Electrical and Electronic Components

Click to view similar products for [Battery Management](#) category:

Click to view products by [ROHM](#) manufacturer:

Other Similar products are found below :

[MP26121DQ-LF-P](#) [NCP1855FCCT1G](#) [FAN54063UCX](#) [LC05132C01NMTTTG](#) [SN2040DSQR](#) [ME4075AM5G](#) [AP5054HTCER](#) [XPD977B](#)
[XPD977B18](#) [4056H](#) [DW01](#) [DW06](#) [CM1002-UD](#) [CM1002-W](#) [CM1002-X](#) [CM1002-Y](#) [CM1006-B](#) [CM1006-Q](#) [CM1006-WB](#) [CM1006-LCD](#)
[CM1006-LBD](#) [CM1006-WF](#) [CM1006-LF](#) [CM1006-WG](#) [CM1006-WH](#) [CM1006-LG](#) [CM1003-S02BD](#) [CM1003-S09EA](#) [CM1003-S10ED](#)
[CM1003-S11ED](#) [CM1003-S12BC](#) [CM1003-S13CC](#) [CM1003-S24BC](#) [CM1003-S26BC](#) [CM1003-WAD](#) [CM1003-BBD](#) [CM1003-BFD](#)
[CM1003-BND](#) [CM1003-BLD](#) [CM1003-DAD](#) [CM1003-BMD](#) [CM1003-BPD](#) [CM1003-BKD](#) [CM1003-BAE](#) [CM1003-BHE](#) [CM1102B-FF](#)
[CM1102B-FD](#) [CM1102B-GD](#) [CM1112-DAE](#) [CM1112-DBE](#)