

# 1.5A LED Camera Flash Driver with I<sup>2</sup>C Compatible Interface

## BD7710GWL

### ●General Description

The BD7710GWL is 1.5A Flash LED Driver with Synchronous rectification step up DC/DC converter that can drive 3LED.

It is possible to set by I2C interface.

With synchronous rectification (no external schottky barrier diode required) and small package, they can save mount space.

### ●Features

- 1) Synchronous rectification step-up DC/DC converter.(no external S.B.D.)
- 2) 3 channel current driver (maximum total 1.6A)
- 3) It is possible to control register by I2C interface
- 4) Programmable lighting mode
- 5) Programmable LED current
- 6) Programmable Battery drop protection
- 7) Programmable Flash timer
- 8) Rich safety function
  - Over Current Protection (OCP)
  - Over Voltage Protection (OVP)
  - VOUT Short Protection
  - LED short/open Protection
  - UVLO
  - TSD
  - Battery drop Protection
  - LED Temperature Monitoring

### ●Key Specifications

■ VBAT Input voltage	2.7V to 5.5V
■ Operating temperature range	-40°C to +85°C
■ Quiescent Current	3.0μA(MAX)
■ LED Current	1.6A(MAX)
■ Switching frequency	2MHz(typical)

### ●Packages

UCSP50L2	1.90 mm × 2.10 mm × 0.55 mm(MAX)
----------	----------------------------------

### ●Applications

- Single/Dual/Triple White LED Flash Supply for Cell Phones and Smart-Phones
- DSC,DVC
- Video Lighting for Digital Video Applications
- Amusement accessory

### ●Typical Application Circuits

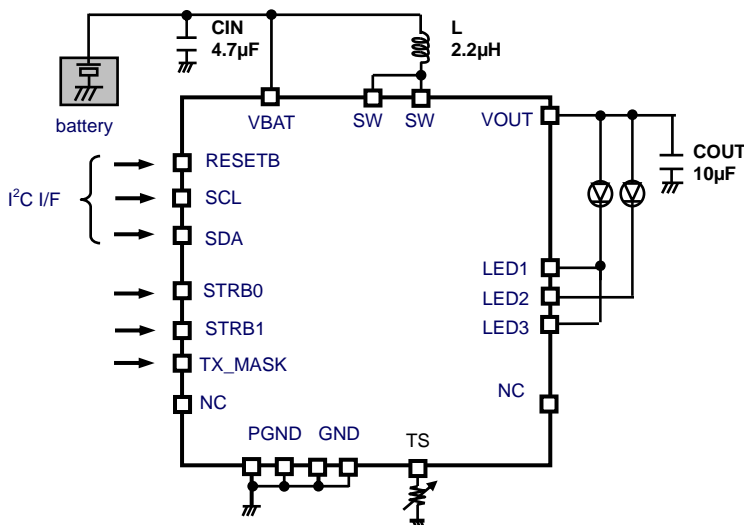

Figure 1. 1.5A application Block diagram

### ●Pin Configuration [Bottom View]

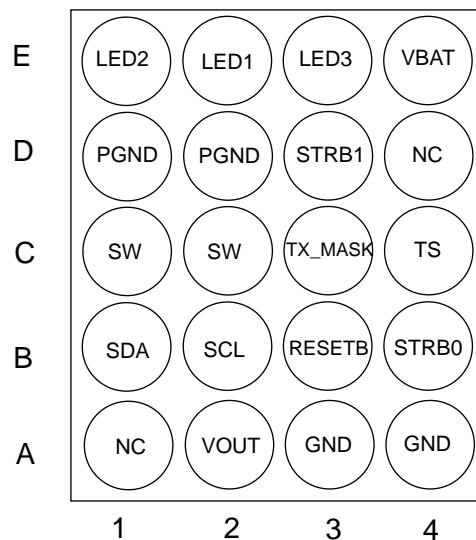

Figure 2. Pin Configuration

### ● Absolute Maximum Ratings (Ta=25 °C)

Parameter	Symbol	Limits	Unit
Maximum voltage	VMAX	7	V
Power Dissipation (note1)	Pd	820	mW
Operating Temperature Range	Topr	-40 to +85	°C
Storage Temperature Range	Tstg	-55 to +150	°C

Note1) Power dissipation deleting is 6.56 mW/°C, when it's used in over 25°C.  
(ROHM's standard board has been mounted.)

The power dissipation of the IC has to be less than the one of the package.

### ● Operating conditions (Ta= -40 to 85 °C)

Parameter	Symbol	Limits	Unit
VBAT input voltage	VBAT	2.7 to 5.5	V

### ● Electrical characteristics

(Unless otherwise noted, Ta = 25°C, VBAT=3.6V)

Parameter	Symbol	Min.	Typ.	Max.	Units	Condition
<b>[Supply Current]</b>						
Quiescent Current	Iq	-	0.5	3.0	μA	At OFF
Current Consumption (Device not switching)	Idd1	-	9.5	-	mA	
UVLO Voltage	VUVLO	1.8	2.1	2.4	V	VBAT falling edge
<b>[Switching Regulator]</b>						
SW NMOS on resistance	Ronn	-	180	-	mΩ	
SW PMOS on resistance	Ronp	-	180	-	mΩ	
Switching frequency	Fsw	1.6	2	2.4	MHz	
Duty cycle limit	Duty	-	80	-	%	
Output voltage range	Vo	-	-	5.5	V	
FB Voltage1	VFBT	-	200	300	mV	In Boost On, Torch mode
FB Voltage2	VFBF	-	400	-	mV	In Boost On, Flash mode
Over voltage Protection	VOVP	4.5	4.65	4.8	V	0000 ≤ OVP[3:0] ≤ 0100
		5.8	6.0	6.2	V	0101 ≤ OVP[3:0] ≤ 1111
VOUT Short Protection	Vshto	-	1.5	-	V	
Over Current Protection	OCP	-	2.0	-	A	*1 ILIM[4]=1
<b>[LED Temperature monitoring]</b>						
TS Current source	Isource	-	25	-	μA	
TS Resistance (Warning temperature)	Lwarn	-	42.0	-	kΩ	LEDWARN bit = 1
TS Resistance (Hot temperature)	Lhot	-	13.8	-	kΩ	LEDHOT bit = 1
<b>[Current Driver]</b>						
Torch LED Current accuracy	ITdiff	-10	0	+10	%	ILED=100mA
Flash LED Current accuracy	IFdiff	-7.5	0	+7.5	%	ILED= 400mA
<b>[SDA, SCL]</b>						
L level input voltage	VILI	-0.3	-	0.4	V	
H level input voltage	VIHI	1.4	-	VBAT +0.3	V	
L level output voltage	VOLI	0	-	0.3	V	SDA Pin, IOL=3 mA
<b>[RESETB]</b>						
L level input voltage	VILR	-0.3	-	0.3	V	
H level input voltage	VIHR	1.0	-	VBAT +0.3	V	
Pull-down resistance	R <sub>PD</sub>	-	400	-	kΩ	
<b>[STRB0 / STRB1 / TX_MASK]</b>						
L level input voltage	VILE	-0.3	-	0.3	V	
H level input voltage	VIHE	1.0	-	VBAT +0.3	V	
Pull-down resistance	R <sub>PD</sub>	-	400	-	kΩ	

\*1 This parameter is tested with dc measurement.

## ●Terminals

No.	Pin Name	In/ Out	Pin circuit diagram	ESD Diode		Description
				For Power	For GND	
A1	NC	-	-	-	-	Non connect pin
A2	VOUT	Out	D	-	GND	Output voltage.
A3	GND	-	G	VBAT	-	Ground
A4	GND	-	G	VBAT	-	Ground
B1	SDA	In/ Out	I	VBAT	GND	Serial interface address/data line.
B2	SCL	In	H	VBAT	GND	Serial interface clock line.
B3	RESETB	In	A	VBAT	GND	Master hardware reset input.
B4	STRB0	In	A	VBAT	GND	LED 1/2/3 enable logic input.
C1	SW	In	E	-	GND	Inductor connection.
C2	SW	In	E	-	GND	Inductor connection.
C3	TX_MASK	In	A	VBAT	GND	LED Current control input with RF PA synchronization.
C4	TS	In	B	VBAT	GND	NTC resistor connection.
D1	PGND	-	G	VBAT	-	Power ground.
D2	PGND	-	G	VBAT	-	Power ground.
D3	STRB1	In	A	VBAT	GND	LED 1/2/3 enable logic input.
D4	NC	-	-	-	-	Non connect pin
E1	LED2	In	C	-	GND	LED2 driver output.
E2	LED1	In	C	-	GND	LED1 driver output.
E3	LED3	In	C	-	GND	LED3 driver output.
E4	VBAT	In	F	-	GND	Battery connection.

Total 20 pin

●Pin Circuit diagram

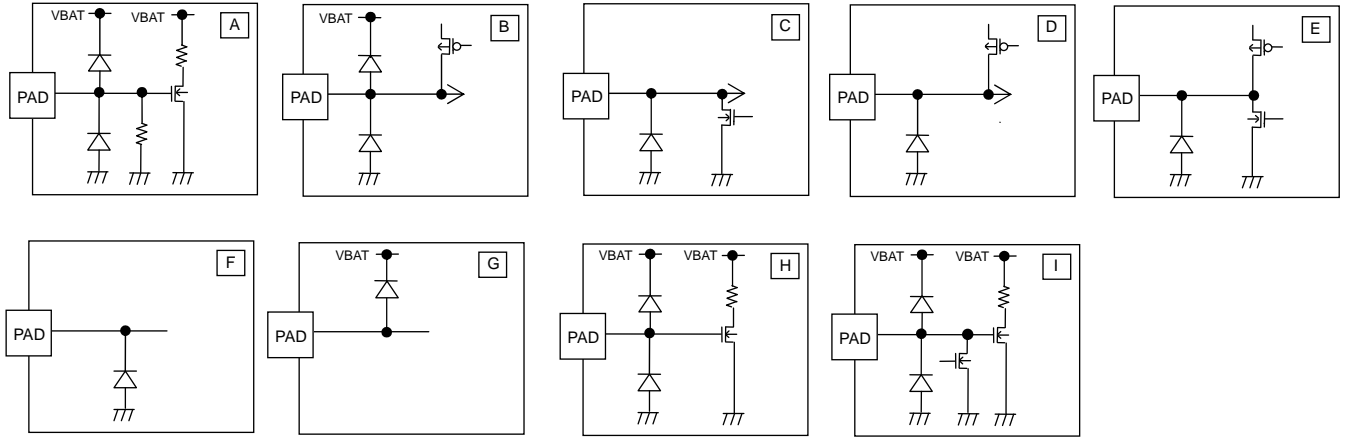

Figure 3. Pin circuit diagram

●Block Diagram

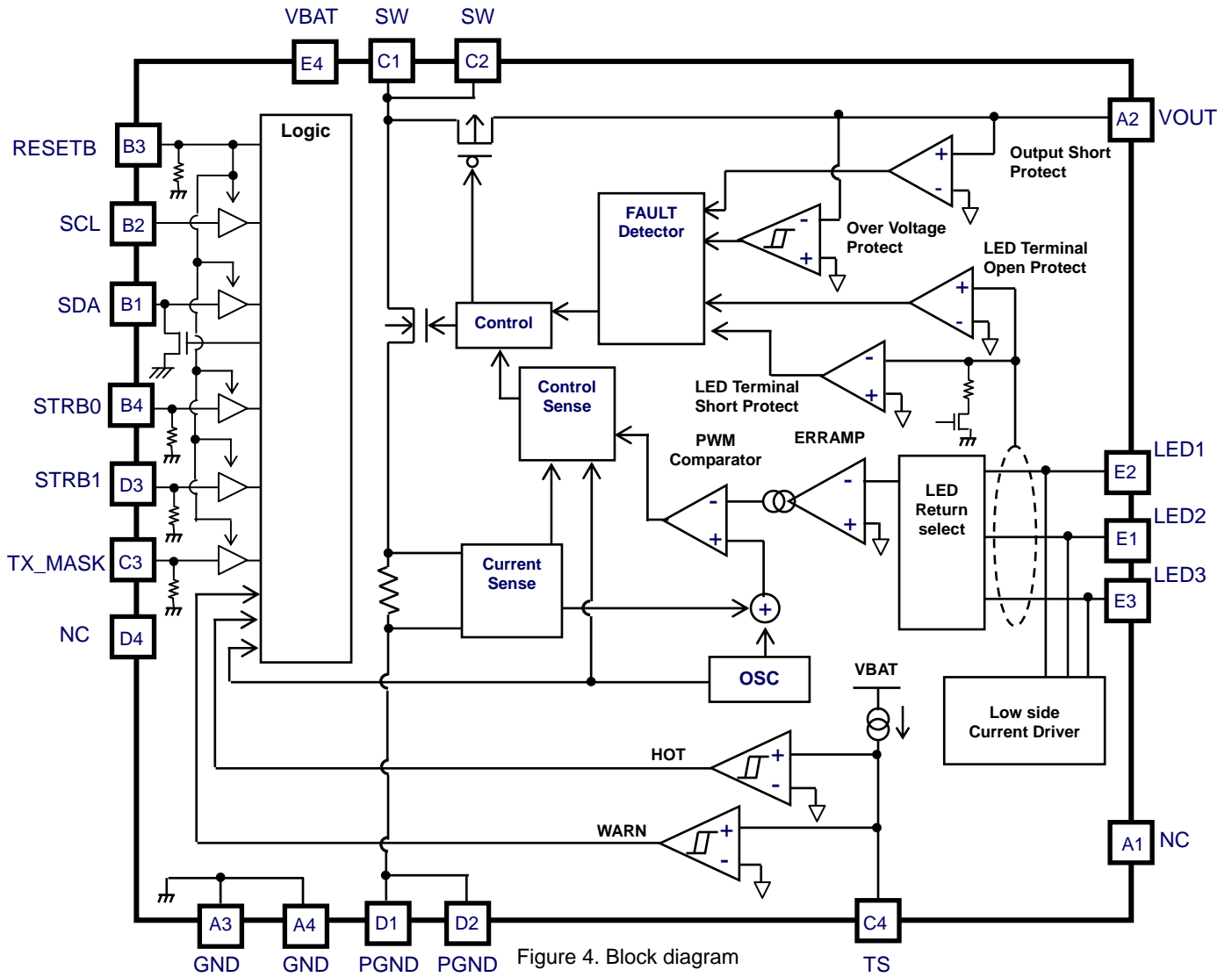

Figure 4. Block diagram

● Typical Characteristics (Reference Data)

Y-axis	X-axis	Figure-No
Quiescent Current	VBAT	Figure5-1
Current Consumption	VBAT	Figure5-2
I <sub>LED</sub> (100mA)	VBAT	Figure5-3
I <sub>LED</sub> (400mA)	VBAT	Figure5-4
Efficiency	VBAT	Figure5-5
UVLO	Temperature	Figure5-6
Frequency	VBAT	Figure5-7
Over Voltage Protection (OVP)	VBAT	Figure5-8
VO <sub>UT</sub> Short Protection	VBAT	Figure5-9
Over Current Protection (OCP)	VBAT	Figure5-10
TS Current source	Temperature	Figure5-11
TS Resistance (Warning temperature)	Temperature	Figure5-12
TS Resistance (Hot temperature)	Temperature	Figure5-13

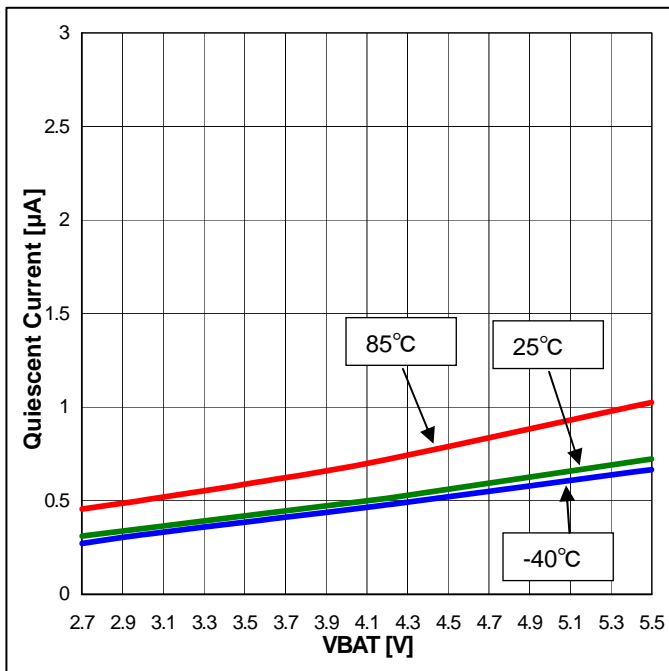

Figure 5-1. Quiescent Current – VBAT

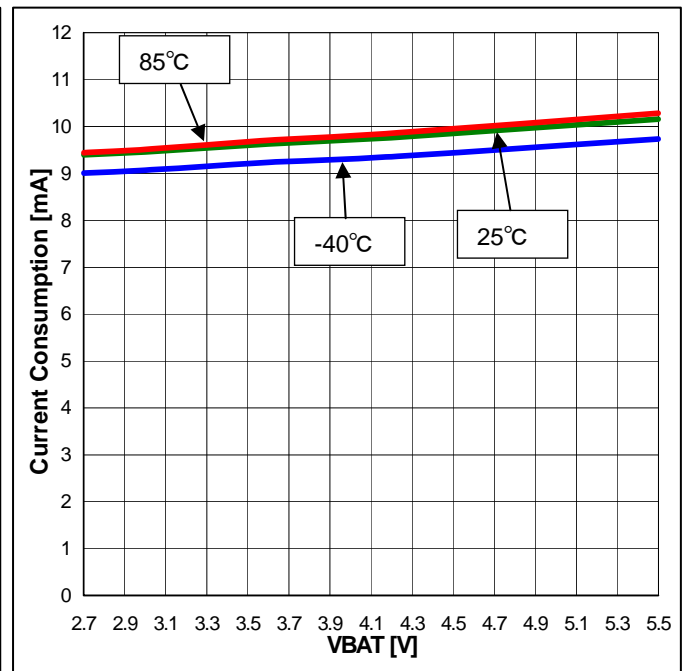

Figure 5-2. Current Consumption - VBAT

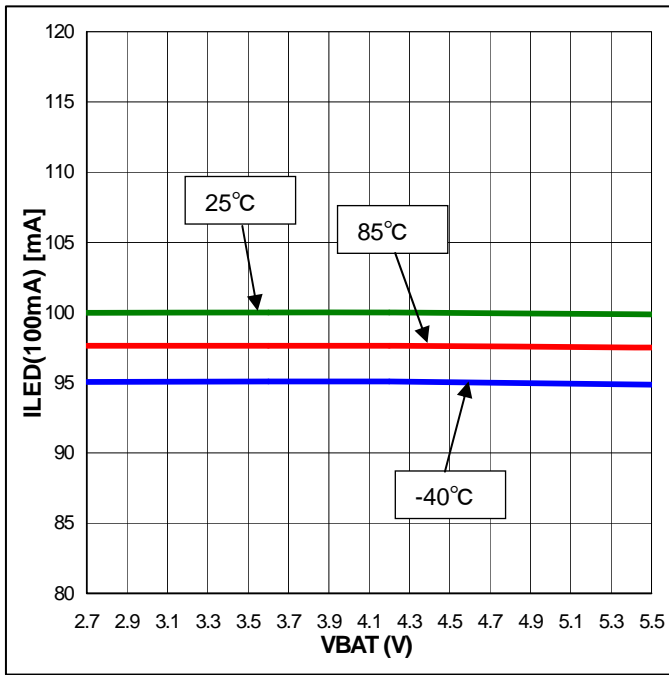

Figure 5-3. ILED(100mA) – VBAT

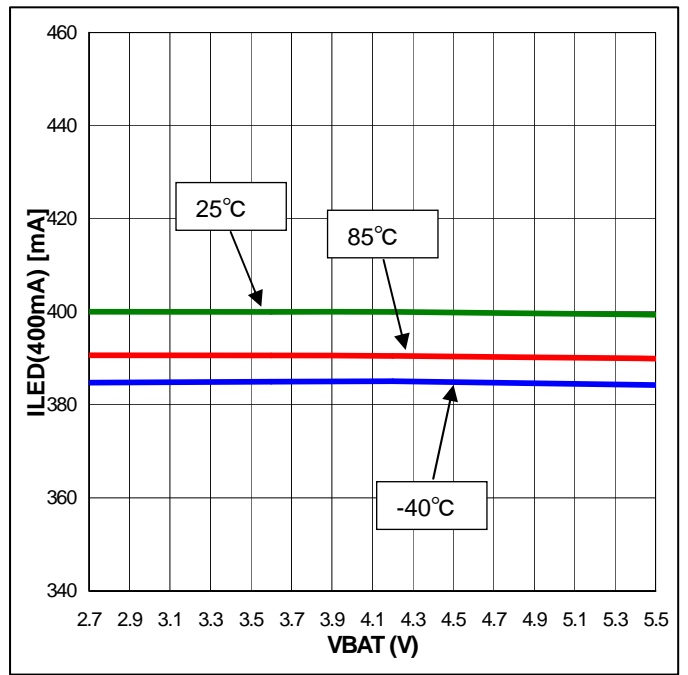

Figure 5-4. ILED(400mA) - VBAT

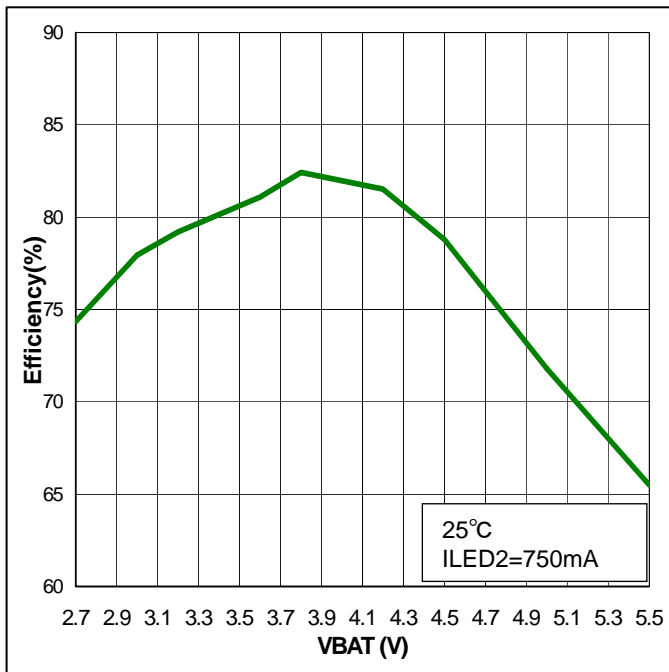

Figure 5-5. Efficiency - VBAT

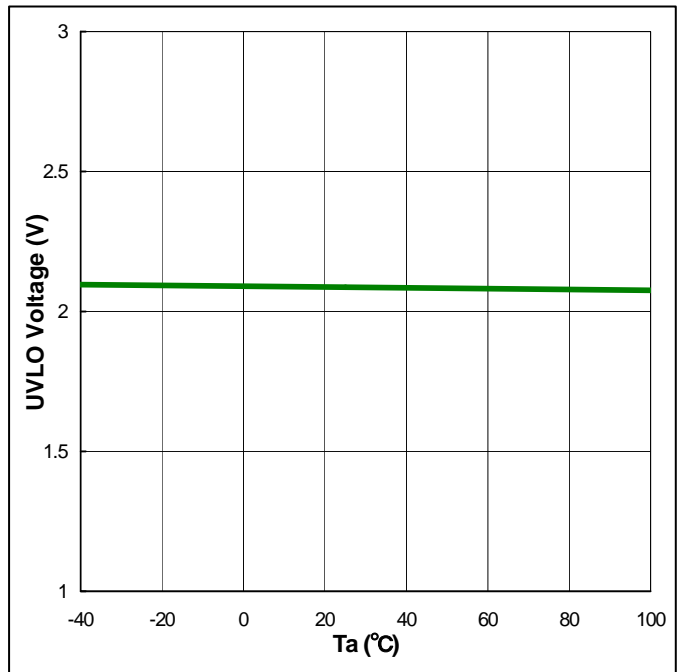

Figure 5-6. UVLO - Temperature

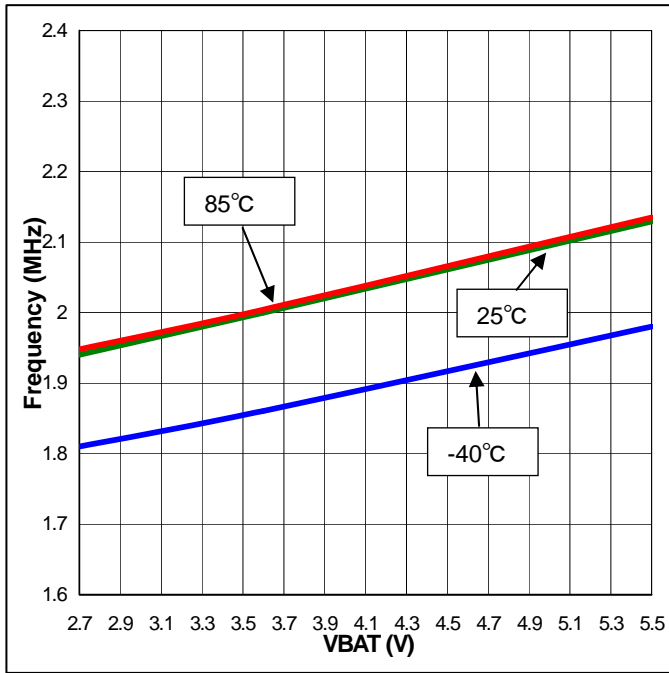

Figure 5-7. Frequency – VBAT

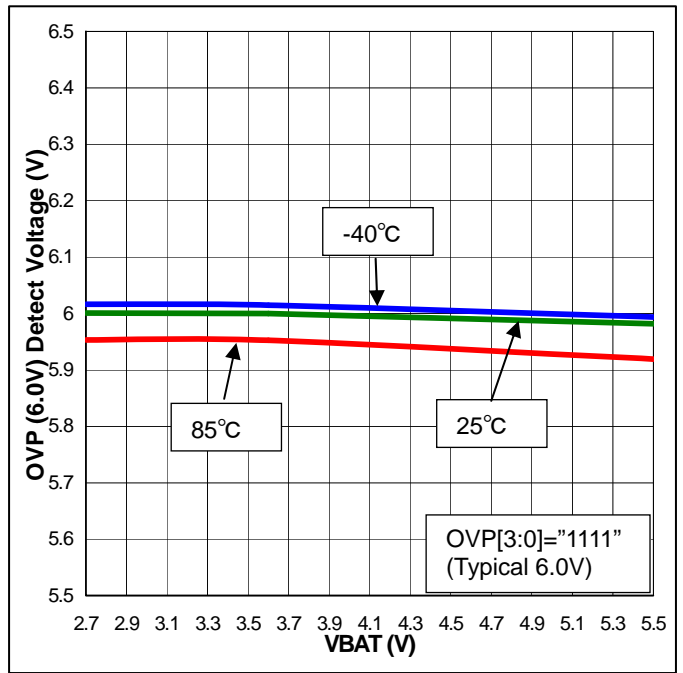

Figure 5-8. Over Voltage Protection (OVP) - VBAT

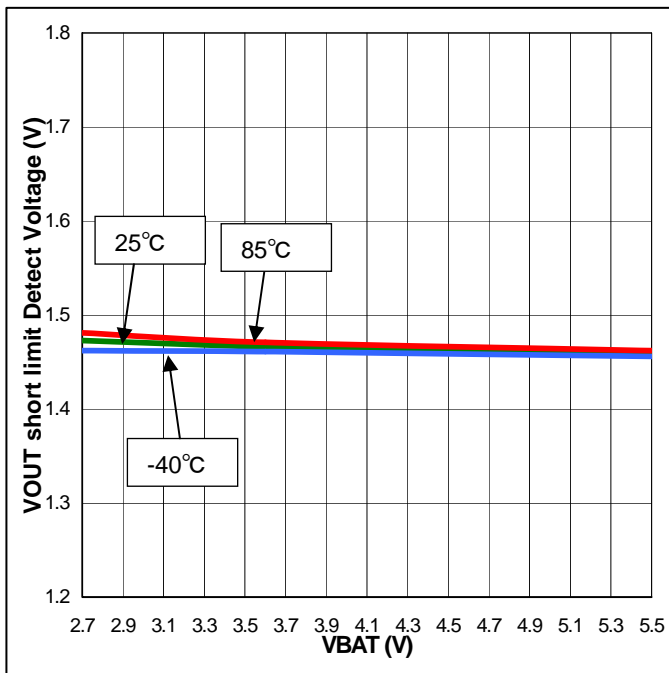

Figure 5-9. VOUT Short Protection – VBAT

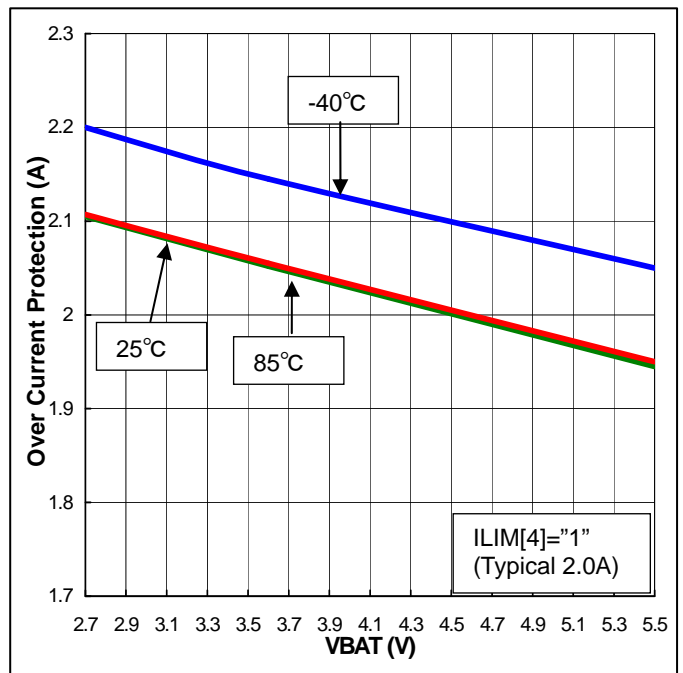

Figure 5-10. Over Current Protection (OCP) – VBAT

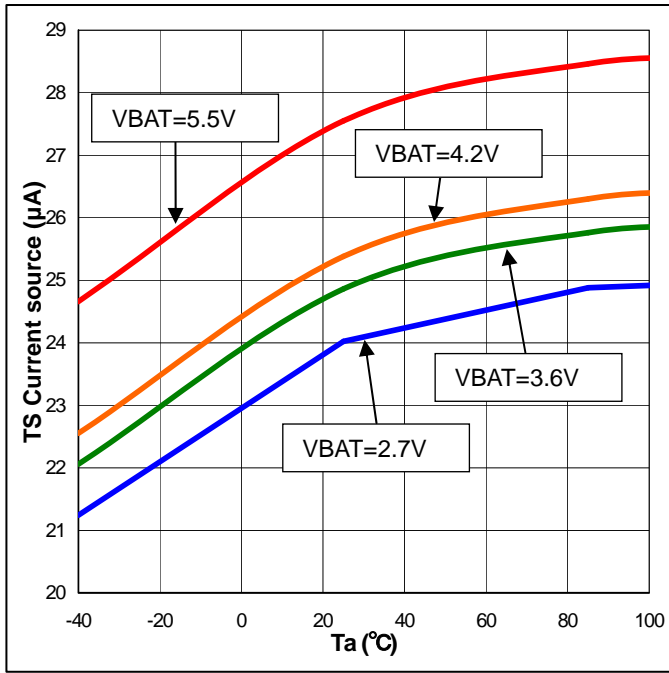

Figure 5-11. TS Current source – Temperature

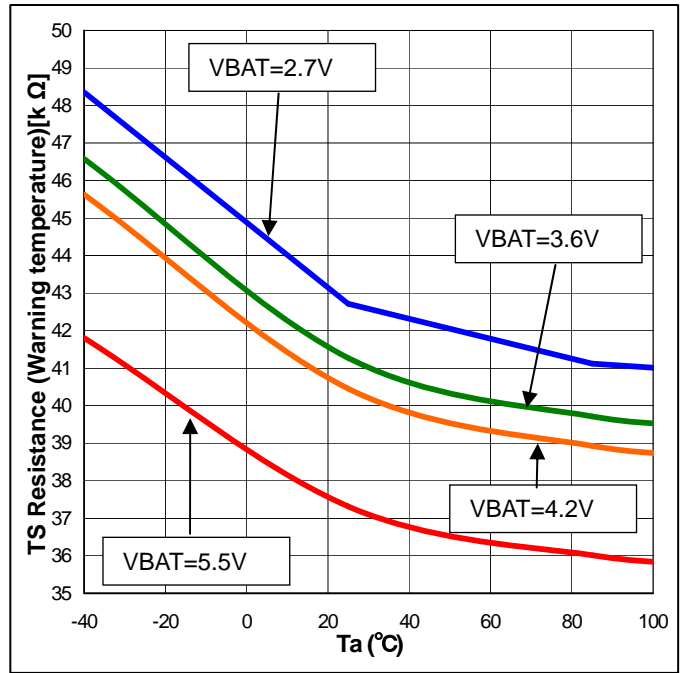

Figure 5-12. TS Resistance (Warning temperature) - Temperature

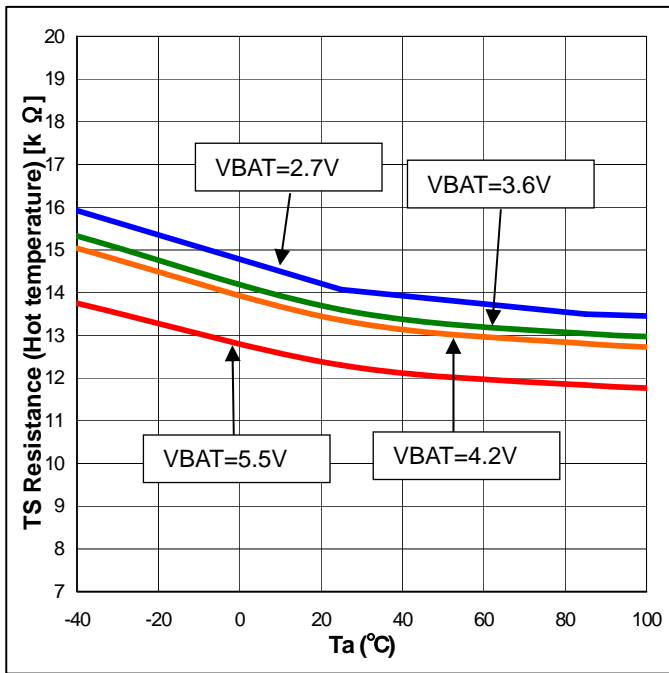

Figure 5-13. TS Resistance (Hot temperature) – Temperature



●Serial interface

It can interface with I<sup>2</sup>C BUS format compatible.

(1) Slave address

A7	A6	A5	A4	A3	A2	A1	R/W
0	1	1	0	0	1	1	0

(2) Bit Transfer

SCL transfers 1-bit data during H. During H of SCL, SDA cannot be changed at the time of bit transfer. If SDA changes while SCL is H, START conditions or STOP conditions will occur and it will be interpreted as a control signal.

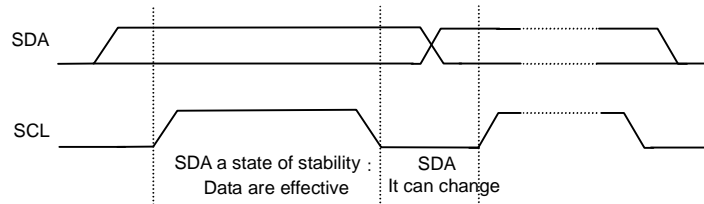

Figure 6. Bit transfer (I<sup>2</sup>C format)

(3) START and STOP condition

When SDA and SCL are H, data is not transferred on the I<sup>2</sup>C- bus. This condition indicates, if SDA changes from H to L while SCL has been H, it will become START (S) conditions, and an access start, if SDA changes from L to H while SCL has been H, it will become STOP (P) conditions and an access end.

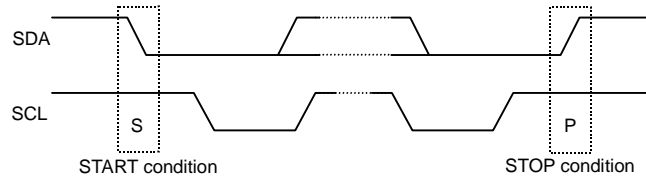

Figure 7. START/STOP condition (I<sup>2</sup>C format)

(4) Acknowledge

It transfers data 8 bits each after the occurrence of START condition. A transmitter opens SDA after transfer 8bits data, and a receiver returns the acknowledge signal by setting SDA to L.

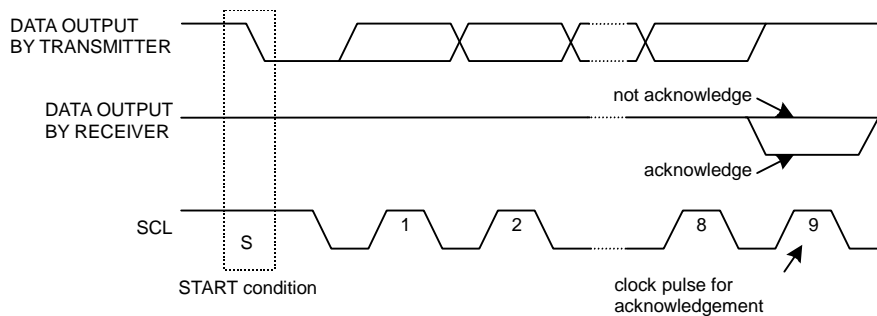

Figure 8. Acknowledge (I<sup>2</sup>C format)

(5) Writing protocol

A register address is transferred by the next 1 byte that transferred the slave address and the write-in command. The 3rd byte writes data in the internal register written in by the 2nd byte, and after 4th byte or, the increment of register address is carried out automatically. However, when a register address turns into the last address (07h), it is set to 00h by the next transmission. After the transmission end, the increment of the address is carried out.

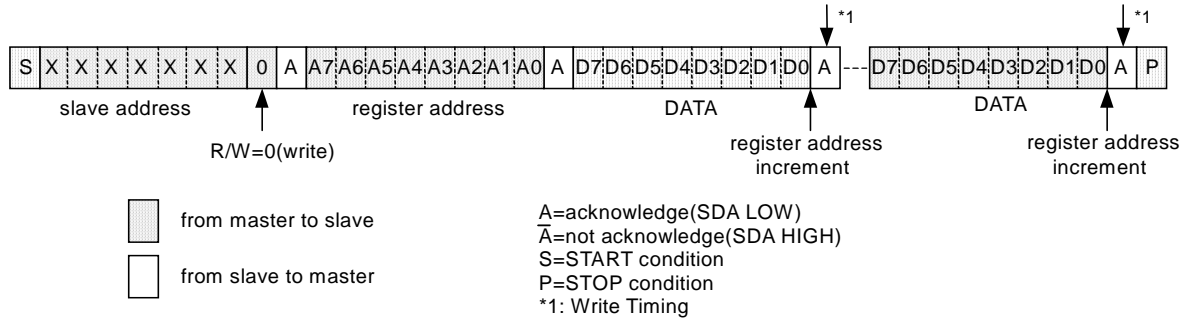

Figure 9. Writing protocol

(6) Reading protocol

It reads from the next byte after writing a slave address and R/W bit. The register to read considers as the following address accessed at the end, and the data of the address that carried out the increment is read after it. If an address turns into the last address, the next byte will read out 00h. After the transmission end, the increment of the address is carried out.

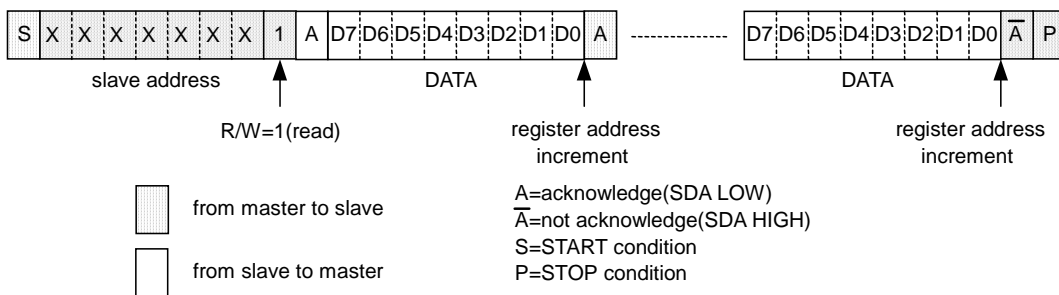

Figure 10. Reading protocol

(7) Multiple reading protocols

After specifying an internal address, it reads by repeated START condition and changing the data transfer direction. The data of the address that carried out the increment is read after it. If an address turns into the last address, the next byte will read out 00h. After the transmission end, the increment of the address is carried out.

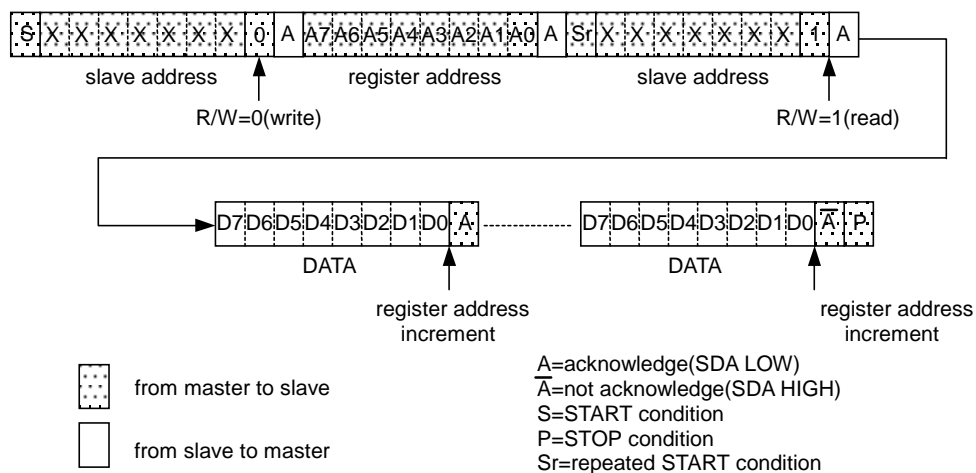

Figure 11. Multiple reading protocols

As for reading protocol and multiple reading protocols, please do A(not acknowledge) after doing the final reading operation. It stops with read when ending by A(acknowledge), and SDA stops in the state of Low when the reading data of that time is 0. However, this state returns usually when SCL is moved, data is read, and A(not acknowledge) is done.

(8) Timing diagram

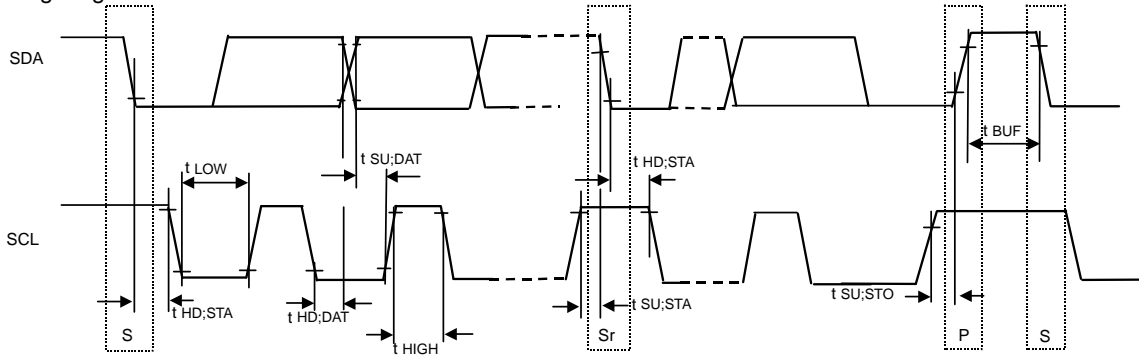

Figure 12. Timing diagram (I<sup>2</sup>C format)

(9) Electrical Characteristics (Unless otherwise specified, Ta=25 °C, VBAT=3.6V)

Parameter	Symbol	Standard-mode			Fast-mode			Unit
		Min.	Typ.	Max.	Min.	Typ.	Max.	
<b>I<sup>2</sup>C BUS format (F/S-mode)</b>								
SCL clock frequency	F <sub>SCL</sub>	0	-	100	0	-	400	kHz
LOW period of the SCL clock	t <sub>LOW</sub>	4.7	-	-	1.3	-	-	μs
HIGH period of the SCL clock	t <sub>HIGH</sub>	4.0	-	-	0.6	-	-	μs
Hold time (repeated) START condition After this period, the first clock is generated	t <sub>HD;STA</sub>	4.0	-	-	0.6	-	-	μs
Set-up time for a repeated START condition	t <sub>SU;STA</sub>	4.7	-	-	0.6	-	-	μs
Data hold time	t <sub>HD;DAT</sub>	0	-	3.45	0	-	0.9	μs
Data set-up time	t <sub>SU;DAT</sub>	250	-	-	100	-	-	ns
Set-up time for STOP condition	t <sub>SU;STO</sub>	4.0	-	-	0.6	-	-	μs
Bus free time between a STOP and START condition	t <sub>BUF</sub>	4.7	-	-	1.3	-	-	μs

Parameter	Symbol	C <sub>b</sub> =100pF(max)			C <sub>b</sub> =400pF			Unit
		Min.	Typ.	Max.	Min.	Typ.	Max.	
<b>I<sup>2</sup>C BUS format (Hs-mode)</b>								
SCL (SCLH) clock frequency	F <sub>SCL</sub>	0	-	3.4	0	-	1.7	MHz
LOW period of the SCL (SCLH) clock	T <sub>LOW</sub>	160	-	-	320	-	-	ns
HIGH period of the SCL (SCLH) clock	t <sub>HIGH</sub>	60	-	-	120	-	-	ns
Hold time (repeated) START condition After this period, the first clock is generated	t <sub>HD;STA</sub>	160	-	-	320	-	-	ns
Set-up time for a repeated START condition	t <sub>SU;STA</sub>	160	-	-	320	-	-	ns
Data hold time	t <sub>HD;DAT</sub>	0	-	70	0	-	150	ns
Data set-up time	t <sub>SU;DAT</sub>	10	-	-	10	-	-	ns
Set-up time for STOP condition	t <sub>SU;STO</sub>	160	-	-	320	-	-	ns
Capacitive load for each bus line [SDA (SDAH) and SCL (SCLH) lines]	C <sub>b</sub>	-	-	100	-	-	400	pF

(Note) For bus line loads C<sub>b</sub> between 100 pF and 400 pF the timing parameters must be linearly interpolated

## ●Register List

Address	R/W	Register data								Function
		D7	D6	D5	D4	D3	D2	D1	D0	
00h	R/W	SFTRST	-	TLED13(2)	TLED13(1)	TLED13(0)	TLED2(2)	TLED2(1)	TLED2(0)	Software Reset Torch LED current setting
01h	R/W	MODE(1)	MODE(0)	FLED2(5)	FLED2(4)	FLED2(3)	FLED2(2)	FLED2(1)	FLED2(0)	Mode control Flash LED current setting
02h	R/W	MODE(1)	MODE(0)	-	FLED13(4)	FLED13(3)	FLED13(2)	FLED13(1)	FLED13(0)	Mode control Flash LED current setting
03h	R/W	FTIM(2)	FTIM(1)	FTIM(0)	HPLF	SELFTIM TO	STT	SFT	TXMASK	Flash timer setting
04h	R/W	-	-	-	ILIM	-	-	-	-	Over Current Protection setting
05h	R/W	-	ENPSM	STSTRB1	-	-	ENLED3	ENLED2	ENLED1	LED Enable
06h	R/W	ENTS	LEDHOT	LEDWARN	-	OVP(3)	OVP(2)	OVP(1)	OVP(0)	Over Voltage Protection setting LED Temperature Monitoring setting
07h	R/W	ENBATDET	BATDET(2)	BATDET(1)	BATDET(0)	-	-	-	-	Battery drop Protection

Input "0" for "-".

A free address has the possibility to assign it to the register for the test.

Access to the register for the test and the undefined register is prohibited.

## ●Register Map

Address 00h < Software Reset / Torch LED current setting >

Address	R/W	Bit7	Bit6	Bit5	Bit4	Bit3	Bit2	Bit1	Bit0
00h	R/W	SFTRST	-	TLED13(2)	TLED13(1)	TLED13(0)	TLED2(2)	TLED2(1)	TLED2(0)
Initial Value	0Ah	0	-	0	0	1	0	1	0

Bit[2:0] : **TLED2(2:0)** LED2 Torch current setting

"000" : 0mA  
 "001" : 25mA  
 "010" : 50mA           \*initial value  
 "011" : 75mA  
 "100" : 100mA  
 "101" : 125mA  
 "110" : 150mA  
 "111" : 175mA

Bit[5:3] : **TLED13(2:0)** LED1,3 Torch current setting

"000" : 0mA  
 "001" : 25mA           \*initial value  
 "010" : 50mA  
 "011" : 75mA  
 "100" : 100mA  
 "101" : 125mA  
 "110" : 150mA  
 "111" : 175mA

Bit6 : (Not used)

Bit7 : **SFTRST** Software Reset

"0" : Reset cancel                   \*initial value  
 "1" : Reset(All register initializing)  
 Refer to "Reset" for detail.

## Address 01h &lt; Mode control / Flash LED current setting &gt;

Address	R/W	Bit7	Bit6	Bit5	Bit4	Bit3	Bit2	Bit1	Bit0
01h	R/W	MODE(1)	MODE(0)	FLED2(5)	FLED2(4)	FLED2(3)	FLED2(2)	FLED2(1)	FLED2(0)
Initial Value	10h	0	0	0	1	0	0	0	0

Bit[5:0] : **FLED2(5:0)** LED2 Flash current setting

“000000” : 0mA

“000001” : 25mA

“000010” : 50mA

“000011” : 75mA

“000100” : 100mA

“000101” : 125mA

“000110” : 150mA

“000111” : 175mA

“001000” : 200mA

“001001” : 225mA

“001010” : 250mA

“001011” : 275mA

“001100” : 300mA

“001101” : 325mA

“001110” : 350mA

“001111” : 375mA

“010000” : 400mA

\*initial value

“010001” : 425mA

“010010” : 450mA

“010011” : 475mA

“010100” : 500mA

“010101” : 525mA

“010110” : 550mA

“010111” : 575mA

“011000” : 600mA

“011001” : 625mA

“011010” : 650mA

“011011” : 675mA

“011100” : 700mA

“011101” : 725mA

“011110” : 750mA

“011111” : 775mA

“100000” : 800mA

•

•

•

“111111” : 800mA

Bit[7:6] : **MODE(1:0)** control

“00” : shutdown mode

\*initial value

“01” : Torch mode

“10” : Flash mode

“11” : shutdown mode

To avoid device shutdown by torch safety timeout, MODE(1:0) bits need to be refreshed within less than 13.0s.

Writing to Address01h Bit[7:6] automatically updates Address 02h Bit[7:6].

## Address 02h &lt; Mode control / Flash LED current setting &gt;

Address	R/W	Bit7	Bit6	Bit5	Bit4	Bit3	Bit2	Bit1	Bit0
02h	R/W	MODE(1)	MODE(0)	-	FLED13(4)	FLED13(3)	FLED13(2)	FLED13(1)	FLED13(0)
Initial Value	08h	0	0	-	0	1	0	0	0

Bit[4:0] : **FLED13(4:0)** LED1,3 Flash current setting

“0000” : 0mA

“00001” : 25mA

“00010” : 50mA

“00011” : 75mA

“00100” : 100mA

“00101” : 125mA

“00110” : 150mA

“00111” : 175mA

“01000” : 200mA

\*initial value

“01001” : 225mA

“01010” : 250mA

“01011” : 275mA

“01100” : 300mA

“01101” : 325mA

“01110” : 350mA

“01111” : 375mA

“10000” : 400mA

•

•

•

“11111” : 400mA

Bit5 : (Not used)

Bit[7:6] : **MODE(1:0)** control

“00” : shutdown mode

\*initial value

“01” : Torch mode

“10” : Flash mode

“11” : shutdown mode

To avoid device shutdown by torch safety timeout, MODE(1:0) bits need to be refreshed within less than 13.0s.

Writing to Address02h Bit[7:6] automatically updates Address 01h Bit[7:6].

Address 03h &lt; Flash timer setting / TX\_MASK setting&gt;

Address	R/W	Bit7	Bit6	Bit5	Bit4	Bit3	Bit2	Bit1	Bit0
03h	R/W	FTIM(2)	FTIM(1)	FTIM(0)	HPLF	SELFTIM TO	STT	SFT	TXMASK
Initial Value	C1h	1	1	0	0	0	0	0	1

Bit0 : **TXMASK** TX\_MASK pin function setting

"0" : TX\_MASK pin doesn't affect for output current

"1" : IF TX\_MASK pin =H Flash current is reduced to Torch current.

Bit1 : **SFT** Start/Flash Timer

"0" : No change in the LED current

"1" : LED current ramps to the Flash current level

Bit2 : **STT** Safety Timer Trigger

"0" : FLASH safety timer is level sensitive

"1" : FLASH safety timer is rising edge sensitive

Bit3 : **SELFTIM** Safety Timer Range Selection (write only)

"0" : safety timer range 0

"1" : safety timer range 1

**TO** Time out flag (**read only**)

"0" : No time-out event occurred

"1" : Time-out event occurred

Bit4 : **HPLF** LED failure flag (read only)

"0" : Normal

"1" : LED failed (open or shorted)

Bit[7:5] : **FTIM(2:0)** Flash timer setting

FTIM(2:0)	RANGE0	RANGE1
000	68.2ms	5.3ms
001	102.2ms	10.7ms
010	136.3ms	16.0ms
011	170.4ms	21.3ms
100	204.5ms	26.6ms
101	340.8ms	32.0ms
110	579.3ms	37.3ms
111	852.0ms	71.5ms

(RANGE0:SELFTIM="0" / RANGE1:SELFTIM="1")



## Address 04h &lt; Over Current Protection setting&gt;

Address	R/W	Bit7	Bit6	Bit5	Bit4	Bit3	Bit2	Bit1	Bit0
04h	R/W	-	-	-	ILIM	-	-	-	-
Initial Value	01h	-	-	-	1	-	-	-	-

Bit[3:0] : (Not used)

Bit[4] : **ILIM** Over Current Protection setting

“0” : 1.5A

“1” : 2.0A

Bit[7:5] : (Not used)

## Address 05h &lt; LED Enable &gt;

Address	R/W	Bit7	Bit6	Bit5	Bit4	Bit3	Bit2	Bit1	Bit0
05h	R/W	-	ENPSM	STSTRB1	-	-	ENLED3	ENLED2	ENLED1
Initial Value	62h	-	1	1	-	-	0	1	0

Bit0 : **ENLED1** LED1 enable  
 "0" : LED1 input is disabled  
 "1" : LED1 input is enabled

Bit1 : **ENLED2** LED2 enable  
 "0" : LED2 input is disabled  
 "1" : LED2 input is enabled

Bit2 : **ENLED3** LED3 enable  
 "0" : LED3 input is disabled  
 "1" : LED3 input is enabled

Bit[4:3] : (Not used)

Bit5 : **STSTRB1** STRB1 Input Status bit (**read only**)

Bit6 : **ENPSM** Enable Power-save mode  
 "0", "1" : Power-save mode is enabled

Bit7 : (Not used)

Address 06h < Over Voltage Protection setting, LED Temperature Monitoring setting>

Address	R/W	Bit7	Bit6	Bit5	Bit4	Bit3	Bit2	Bit1	Bit0
06h	R/W	ENTS	LEDHOT	LEDWARN	-	OVP(3)	OVP(2)	OVP(1)	OVP(0)
Initial Value	09h	0	0	0	-	1	0	0	1

Bit[3:0] : **OVP(3:0)** Over Voltage Protect setting

“0000” : 4.65V

“0001” : 4.65V

“0010” : 4.65V

“0011” : 4.65V

“0100” : 4.65V

“0101” : 6.0V

“0110” : 6.0V

“0111” : 6.0V

“1000” : 6.0V

“1001” : 6.0V \*initial value

“1010” : 6.0V

“1011” : 6.0V

“1100” : 6.0V

“1101” : 6.0V

“1110” : 6.0V

“1111” : 6.0V

Bit4 (not used)

Bit5 : **LEDWARN** LED Temperature Warning Flag **\*(read only)**

This flag is reset after readout.

0 : TS input voltage  $\geq 1.05V$

1 : TS input voltage  $< 1.05V$

When Detection of “LED temperature Warning” was continued for 20 $\mu$ s at Torch / Flash mode, LEDWARN becomes to '1'.

**[NOTE]**

Even if this readout nothing, the detect operation of LEDWARN must be performed

Bit6 : **LEDHOT** LED Excessive Temperature Flag

This bit can be reset by writing a logic level zero.

0 : TS input voltage  $\geq 0.345V$

1 : TS input voltage  $< 0.345V$

When Detection of “LED temperature Hot” was continued for 20 $\mu$ s at Torch / Flash mode, LEDHOT becomes to '1'.

And This IC goes automatically in shutdown mode to avoid damaging the LED. MODE[1:0] bits are reset.

This status(bit="1") is latched until the LEDHOT flag gets cleared by software.

Bit7 : **ENTS** LED Temperature Monitoring setting.

0: LED Temperature Monitoring disable

1: LED Temperature Monitoring enable

## Address 07h &lt; Battery drop Protection &gt;

Address	R/W	Bit7	Bit6	Bit5	Bit4	Bit3	Bit2	Bit1	Bit0
07h	R/W	ENBATDET	BATDET(2)	BATDET(1)	BATDET(0)	-	-	-	-
Initial Value	40h	0	1	0	0	-	-	-	-

Bit[3:0] : (Not used)

Bit[6:4] : **BATDET(2:0)** Battery drop Protection

“000” : 50mV

“001” : 75mV

“010” : 100mV

“011” : 125mV

“100” : 150mV \*initial value

“101” : 175mV

“110” : 200mV

“111” : 225mV

Bit7 : **ENBATDET** Enable for Battery drop Protection

“0” : Battery drop protection disable

“1” : Battery drop protection enable

## ●Functional Description

### 1. Reset

There are two kinds of reset, software reset and hardware reset

#### (1) Software reset

- All the registers are initialized by SFTRST="1".
- SFTRST is an automatically returned to "0". (Auto Return 0).

#### (2) Hardware reset

- It shifts to hardware reset by changing RESETB pin "H" → "L".
- The condition of all the registers under hardware reset pin is returned to the Initial Value, and it stops accepting all address.  
All LED driver turn off.
- It's possible to release from a state of hardware reset by changing RESETB pin "L" → "H".

#### (3) Reset sequence

- When software reset was done during hardware reset, software reset is canceled.(Because the Initial Value of software reset is "0")

### 2. Shutdown

Writing 00 to MODE[1:0] bits forces the device into shutdown.

In the Shutdown state:

- The regulator stops switching.
- The high-side PMOS disconnects the load from the input.
- The LEDx pins are high impedance thus eliminating any DC conduction path (Current driver OFF)

### 3. Power up/down sequence

Please take sufficient wait time for each Power/Control signal.

However, If VBAT<2.6V or On TSD, the command input is not effective because of the protection operation.

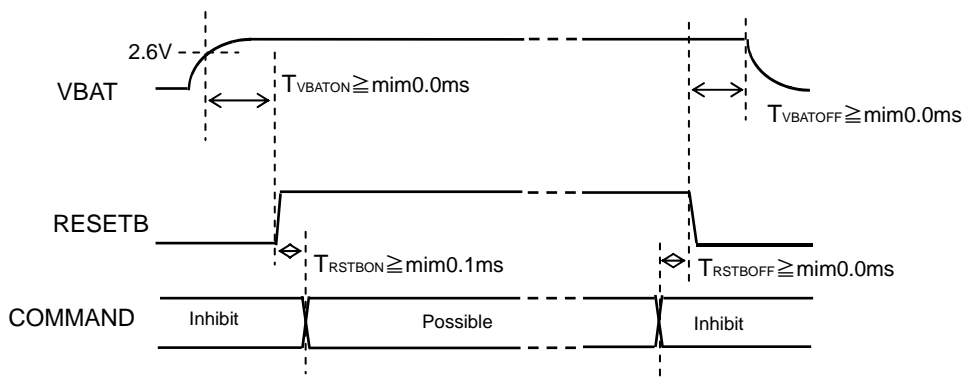

Figure 13. Power up/down sequence

#### 4. PWM current mode DC/DC converter

While this IC is boosting, the lowest voltage of LED1, 2, 3 is detected, PWM duty is decided to be 0.2V (Torch mode) or 0.4V (Flash mode) and output voltage is kept invariably. As for the inputs of the PWM comparator as the feature of the PWM current mode, one is overlapped with error components from the error amplifier, and the other is overlapped with a current sense signal that controls the inductor current into Slope waveform to prevent sub harmonic oscillation. This output controls internal Nch Tr via the RS latch. In the period where internal Nch Tr gate is ON, energy is accumulated in the external inductor, and in the period where internal Nch Tr gate is OFF, energy is transferred to the output capacitor via internal Pch Tr. This IC has many safety functions, and their detection signals stop switching operation at once.

#### 5. Pulse skip control

This IC regulates the output voltage using an improved pulse-skip. In “pulse-skip” mode the error amplifier disables “switching” of the power stages when it detects low output voltage and high input voltage. The oscillator halts and the controller skip switching cycles. The error amplifier reactivates the oscillator and starts switching of the power stages again when this IC detects low input voltage.

The “pulse-skip” regulation minimizes the operating current because this IC does not switch continuously and hence the losses of the switching are reduced. When the error amplifier disables “switching”, the load is also isolated from the input.

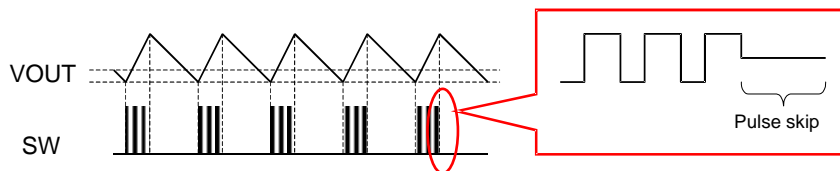

Figure 14. Pulse skip control

## 6.DC/DC Soft start function

Soft start function will prevent IC from appearing the In-rush current.  
The detail of soft start is as following.

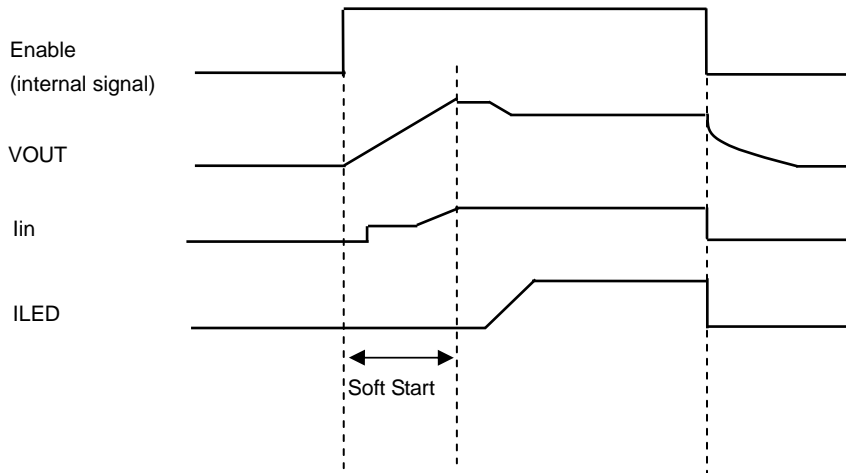

Figure 15. Soft Start with enable signal

## 7. Flash / Torch mode control

Register (I <sup>2</sup> C control)		External pin		State of device	
MODE(1)	MODE(0)	STRB0	STRB1	MODE	behavior
0	0	*	*	shutdown	Stand-by for Flash/Torch
1	1	*	*	shutdown	Stand-by for Flash/Torch
0	1	*	0	Torch	Torch with safety timer
		*	1		Torch without safety timer
1	0	0	0	Flash	Stand-by for Flash/Torch
		0	1		Flash
		1	0		Flash
		1	1		Torch without safety timer

Flash/Torch control can be done by I<sup>2</sup>C register and external pin.

MODE[1:0]: Mode select

“00” : shutdown mode

“01” : Torch mode

“10” : Flash mode

“11” : shutdown mode

For Torch mode, a watchdog timer is implemented; This must be refreshed within 13.0 seconds. This function can be disabled, as described below.

MODE[1:0] = 01 : The STRB0, STRB1 inputs are disabled. The device regulates the LED current in torch mode(TLED bits) regardless of the STRB0, STRB1 inputs and the START\_FLASH/TIMER (SFT) bit. To avoid device shutdown because of the torch safety timeout, MODE[1:0] must be refreshed within less than 13.0 seconds (STRB1=0). The torch watchdog timer can be disabled by pulling the STRB1 signal high.

MODE[1:0] = 10 : The STRB0, STRB1 inputs are enabled. The flash pulse can be triggered by these synchronization signals, or by a software command (START\_FLASH/TIMER (SFT) bit). The LEDs are enabled/disabled according to the STRB0, STRB1 input. The flash safety timer is activated, and the torch watchdog timer is disabled.

## 8. LED Current Ramp-Up / Down (Flash mode)

LED Current Ramp-Up	Istep = 25mA Trise = 12μs
LED Current Ramp-Down	Istep = 25mA Tfall = 0.5μs

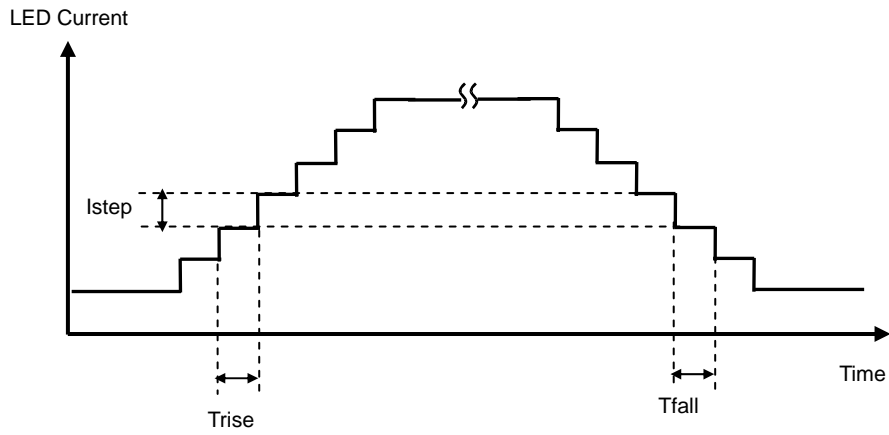

Figure 16. Flash LED current Ramp-Up/Down



9. Example of Flash / Torch mode control

<Torch control example>

Ex1. Torch with safety timer

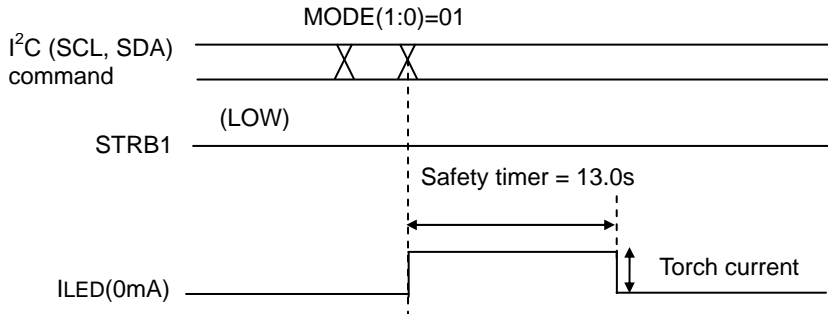

Figure 17. Torch with safety timer

Ex2. Torch without safety timer

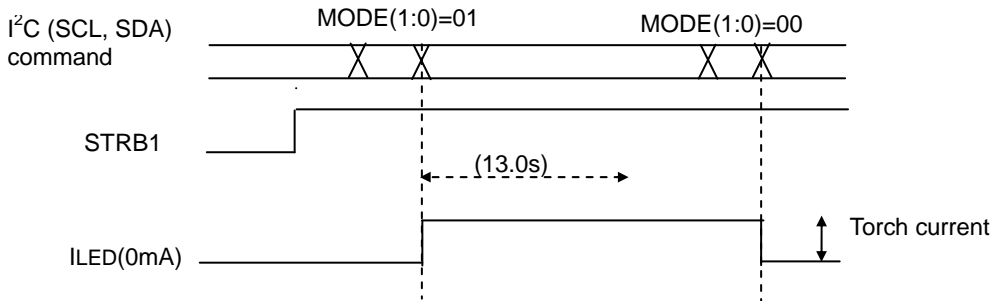

Figure 18. Torch without safety timer

<Flash control example>

(Unless otherwise specified STRB1=0)

Ex3. Flash synchronized with STRB0

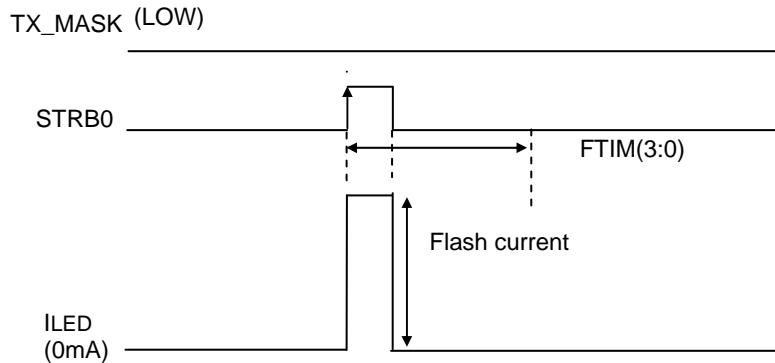

Figure 19. Flash synchronized with STRB0

Ex4. Flash with safety timer

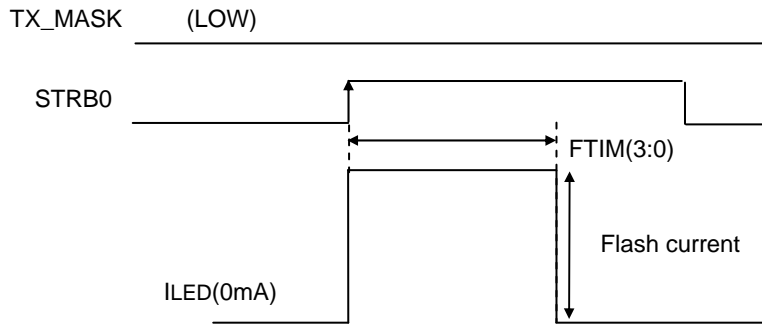

Figure 20. Flash with safety timer

Ex5. Flash inhibit during safety timer

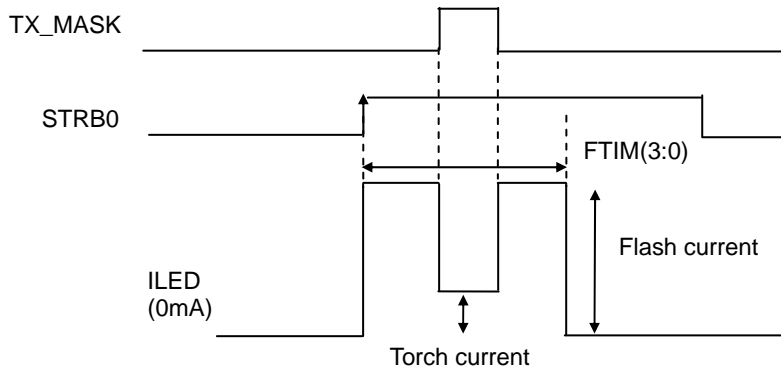

Figure 21. Flash inhibit during safety timer

Ex6. Flash mask by TX\_MASK

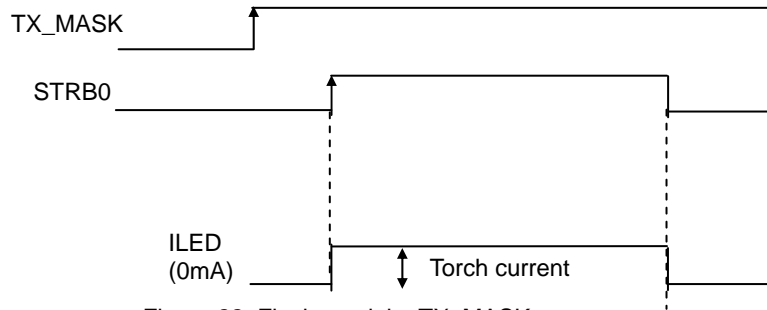

Figure 22. Flash mask by TX\_MASK

Ex7. Flash mask by STRB1

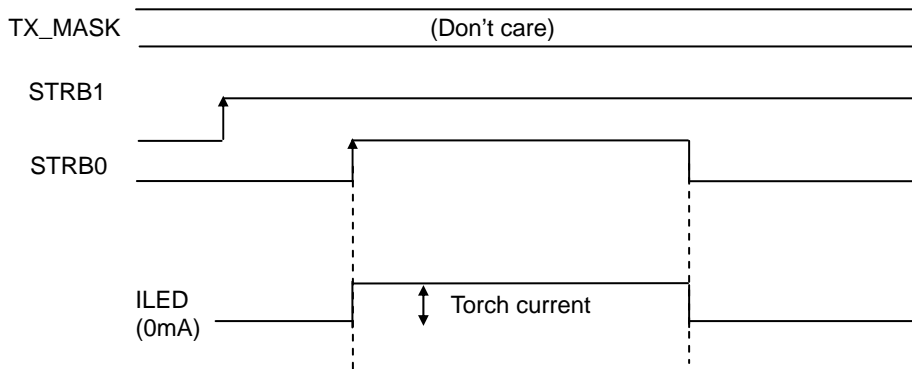

Figure 23. Flash mask by STRB1

**10. Over Voltage Protection / LED open Protection**

At such an error of output open as the output DC/DC and the LED is not connected to IC, the DC/DC will boost too much and the VOUT terminal exceed the absolute maximum ratings, and may destruct the IC. Therefore, when VOUT becomes sensing voltage or higher, the over voltage limit works, and turns off the output Tr, and the pressure up made stop. And LED1 turns off by LED open Protection. At this moment, the IC changes from activation into non-activation, and the output voltage goes down slowly. And, when the FeedBack of LED1 isn't returned, so that Vout will return normal voltage. When all the LED terminals become open, DC/DC and Current Driver turned off.

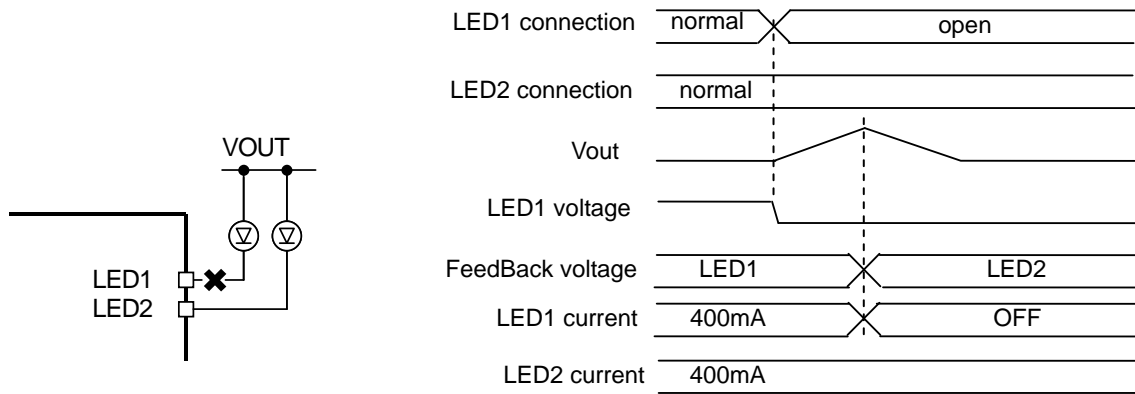

Figure 24. LED open Protection

**11. VOUT Short Protection**

In the case of VOUT is shorted to GND, the coil or internal Tr may be destructed. Therefore, at such an error as VOUT becoming 1.5V or below, and turns off the output Tr, and prevents the coil and the IC from being destructed. And the IC goes automatically into shutdown, and current does not flow to the coil (0mA).

**12. LED short Protection (LED1,2,3 – VOUT short)**

This IC has LED short protection. At start-up, each LED pin pull-down at 250kohm (typ.).At start-up, when it becomes to (Vout×0.8<VLED), it shut down the detected channels (LED Short Protection work).This IC monitors the voltage of each LED terminal after start-up.Then if the LEDs become short during operation, it turn off this IC. In the case of LED short, only the strings which short-circuited is turned off and LED current of other lines continue to turn on. This protection prevent from heat of IC. When all the LED terminals become short, DC/DC and Current Driver turned off.

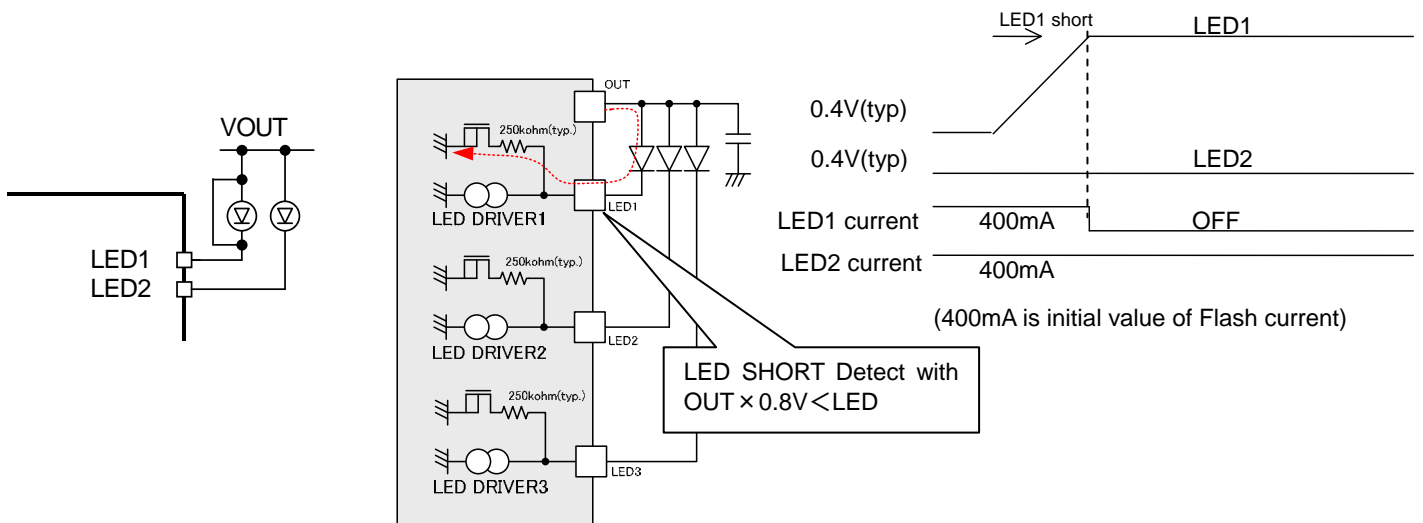

Figure 25. LED short Protection

**13. Thermal shutdown**

This IC has thermal shutdown function. The thermal shutdown works at 175°C or higher, and the IC goes automatically into shutdown.

**14. Over Current Protection**

This IC has Over Current Protection (OCP). When the SW current flows detect resistor that is connected between internal NMOS SW and PGND, Once the inductor current exceeds the current limit, the internal SW switch turns off immediately until the next switching cycle, effectively limiting the peak inductor current each cycle. Because OCP shortens the duty cycle, the output voltage drops if the over-current condition occurs.

**15. Under Voltage Lockout**

This IC has Under Voltage Lockout (UVLO). When VBAT voltage is less than 2.1V(typical), the IC turns off the output Tr, and prevents the coil and the IC from being destructed. And the IC goes automatically into shutdown.

**16. Sensing the LED Temperature**

This IC requires a NTC(Negative temperature coefficient) thermistor for sensing the LED temperature. Once the temperature monitoring feature is activated, a regulated bias current is driven out of the TS port to produce a voltage across the thermistor.

If the temperature of the NTC-thermistor rises due to the heat dissipated by the LED, the voltage on the TS input pin decreases. When this voltage goes below the “warning threshold”, the LEDWARN bit in Address06h is set.

This flag is cleared by reading the register.

If the voltage on the TS input decreases further and falls below “hot threshold”, the LEDHOT bit in Address 06h is set and the device goes automatically into shutdown mode to avoid damaging the LED.

This status is latched until the LEDHOT flag gets cleared by software.

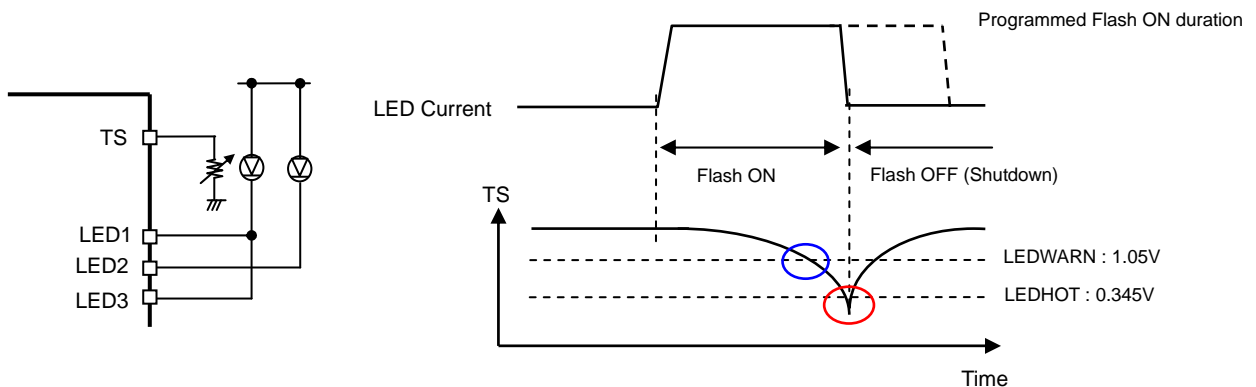

Figure 26. Sensing the LED Temperature

**17. Battery drop Protection**

The battery voltage may drop during a flash strobe. This IC has a function that detects battery voltage drop and stops LED current from ramping further. The limit of battery voltage drop can be set with register of address07h. If battery voltage drop exceeds set voltage, it stops LED current from ramping further and prevents battery voltage drop anymore.

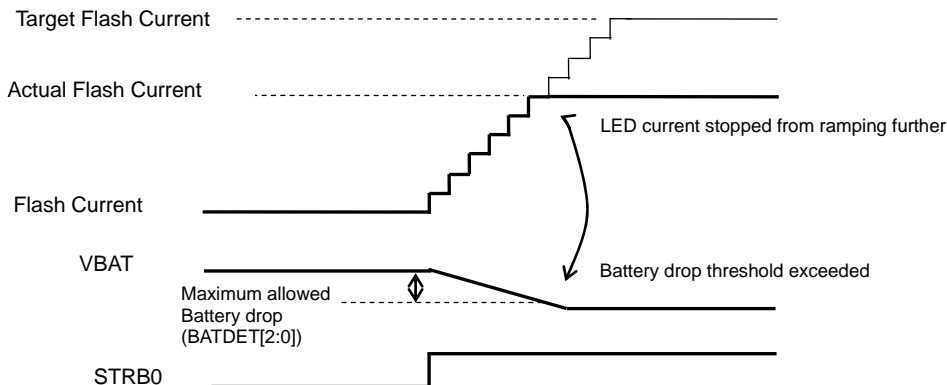

Figure 27. Battery drop Protection

● Recommended Layout Pattern

In order to make the most of the performance of this IC, its layout pattern is very important. Characteristics such as efficiency, ripple and the likes change greatly with layout patterns, which please note carefully. 4-layer board is recommended for better radiation of heat.

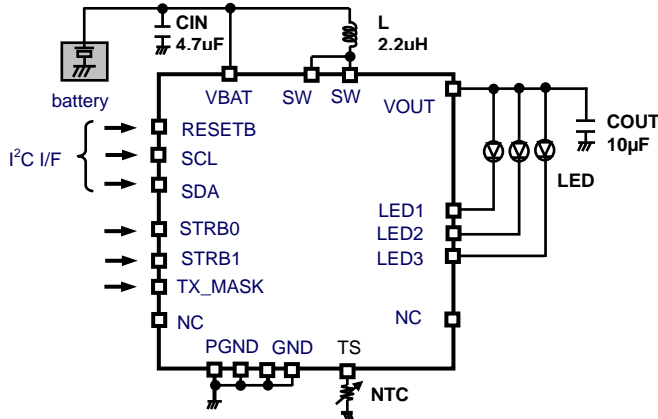

Figure 28. Circuit example

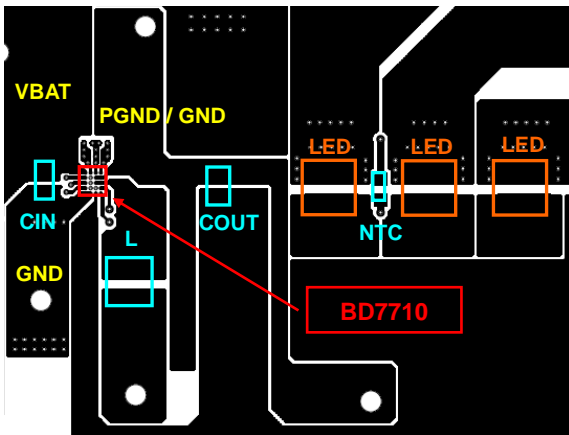

Figure 29. Frontal surface (TOP VIEW)

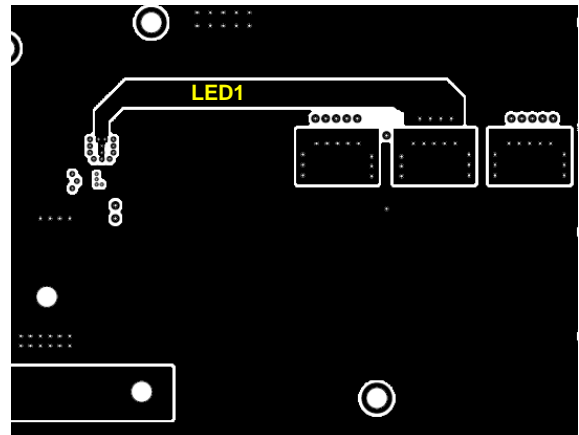

Figure 30. Middle surface1 (TOP VIEW)

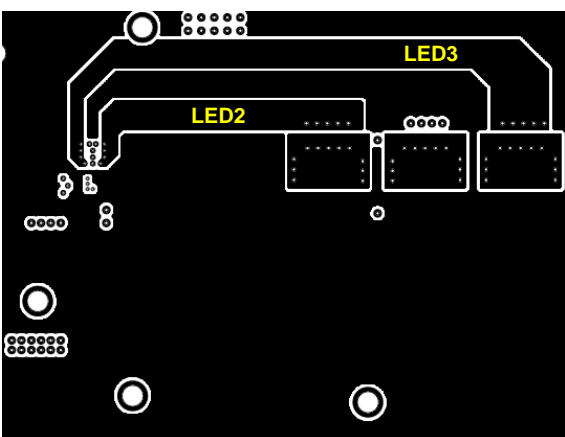

Figure 31. Middle surface2 (TOP VIEW)

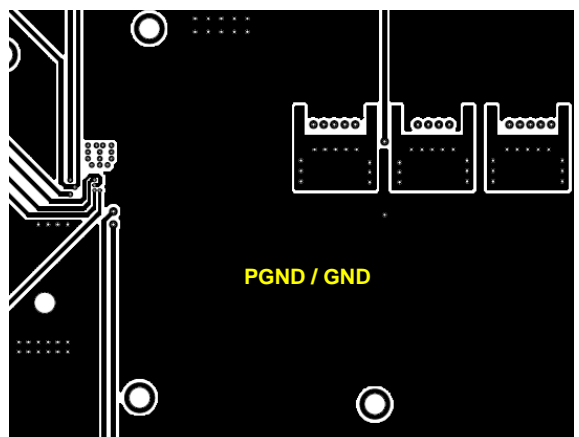

Figure 32. Rear surface (TOP VIEW)

## ● Selection of Components Externally Connected

## Coil(L)

Value	Vendor	Parts number	Size(mm)			DCR (ohm)
			L	W	H	
2.2 $\mu$ H	TDK	VLF302512MT-2R2M	3.0	2.5	1.2	0.055
2.2 $\mu$ H	TDK	VLF504012MT-2R2M	5.0	4.0	1.2	0.046

## Capacitor

Value	Vendor	Parts number	Size(mm)		
			L	W	H
CIN					
4.7 $\mu$ F	MURATA	GRM155R60J475ME47D	1.0	0.5	0.5
COUT					
10 $\mu$ F	MURATA	GRM188B30J106ME47D	1.6	0.8	0.8
22 $\mu$ F	MURATA	GRM188R60J226MEA0D	1.6	0.8	0.8

## NTC

Value	Vendor	Parts number	Size(mm)		
			L	W	H
220k $\Omega$	MURATA	NCP18WM224J03RB	1.6	0.8	0.8

## ● Power dissipation (On the ROHM's standard board)

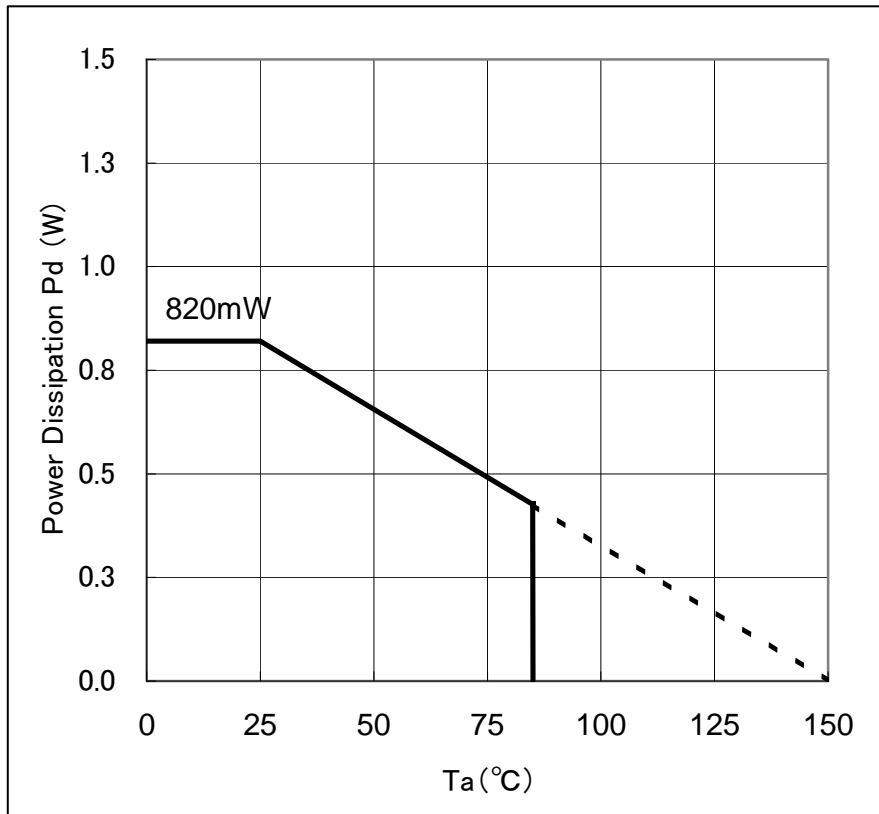

Figure 33. Power dissipation

Information of the ROHM's standard board  
Material : glass-epoxy  
Size : 50mm × 58mm × 1.75mm (8<sup>th</sup> layer)

**●Cautions on use**

- ( 1 ) Absolute Maximum Ratings  
An excess in the absolute maximum ratings, such as supply voltage, temperature range of operating conditions, etc., can break down devices, thus making impossible to identify breaking mode such as a short circuit or an open circuit. If any special mode exceeding the absolute maximum ratings is assumed, consideration should be given to take physical safety measures including the use of fuses, etc.
- ( 2 ) Operating conditions  
These conditions represent a range within which characteristics can be provided approximately as expected. The electrical characteristics are guaranteed under the conditions of each parameter.
- ( 3 ) Reverse connection of power supply connector  
The reverse connection of power supply connector can break down ICs. Take protective measures against the breakdown due to the reverse connection, such as mounting an external diode between the power supply and the IC's power supply terminal.
- ( 4 ) Power supply line  
Design PCB pattern to provide low impedance for the wiring between the power supply and the GND lines. Furthermore, for all power supply terminals to ICs, mount a capacitor between the power supply and the GND terminal. At the same time, in order to use an electrolytic capacitor, thoroughly check to be sure the characteristics of the capacitor to be used present no problem including the occurrence of capacity dropout at a low temperature, thus determining the constant.
- ( 5 ) GND voltage  
Make setting of the potential of the GND terminal so that it will be maintained at the minimum in any operating state. Furthermore, check to be sure no terminals are at a potential lower than the GND voltage including an actual electric transient.
- ( 6 ) Short circuit between terminals and erroneous mounting  
In order to mount ICs on a set PCB, pay thorough attention to the direction and offset of the ICs. Erroneous mounting can break down the ICs. Furthermore, if a short circuit occurs due to foreign matters entering between terminals or between the terminal and the power supply or the GND terminal, the ICs can break down.
- ( 7 ) Operation in strong electromagnetic field  
Be noted that using ICs in the strong electromagnetic field can malfunction them.
- ( 8 ) Inspection with set PCB  
On the inspection with the set PCB, if a capacitor is connected to a low-impedance IC terminal, the IC can suffer stress. Therefore, be sure to discharge from the set PCB by each process. Furthermore, in order to mount or dismount the set PCB to/from the jig for the inspection process, be sure to turn OFF the power supply and then mount the set PCB to the jig. After the completion of the inspection, be sure to turn OFF the power supply and then dismount it from the jig. In addition, for protection against static electricity, establish a ground for the assembly process and pay thorough attention to the transportation and the storage of the set PCB.
- ( 9 ) Input terminals  
In terms of the construction of IC, parasitic elements are inevitably formed in relation to potential. The operation of the parasitic element can cause interference with circuit operation, thus resulting in a malfunction and then breakdown of the input terminal. Therefore, pay thorough attention not to handle the input terminals, such as to apply to the input terminals a voltage lower than the GND respectively, so that any parasitic element will operate. Furthermore, do not apply a voltage to the input terminals when no power supply voltage is applied to the IC. In addition, even if the power supply voltage is applied, apply to the input terminals a voltage lower than the power supply voltage or within the guaranteed value of electrical characteristics.



( 10 ) Ground wiring pattern

If small-signal GND and large-current GND are provided, It will be recommended to separate the large-current GND pattern from the small-signal GND pattern and establish a single ground at the reference point of the set PCB so that resistance to the wiring pattern and voltage fluctuations due to a large current will cause no fluctuations in voltages of the small-signal GND. Pay attention not to cause fluctuations in the GND wiring pattern of external parts as well.

( 11 ) External capacitor

In order to use a ceramic capacitor as the external capacitor, determine the constant with consideration given to a degradation in the nominal capacitance due to DC bias and changes in the capacitance due to temperature, etc.

( 12 ) Thermal shutdown circuit (TSD)

When junction temperatures become 175°C (typical) or higher, the thermal shutdown circuit operates and turns a switch OFF. The thermal shutdown circuit, which is aimed at isolating the LSI from thermal runaway as much as possible, is not aimed at the protection or guarantee of the LSI. Therefore, do not continuously use the LSI with this circuit operating or use the LSI assuming its operation.

( 13 ) Thermal design

Perform thermal design in which there are adequate margins by taking into account the permissible dissipation (Pd) in actual states of use.

( 14 ) Selection of coil

Select the low DCR inductors to decrease power loss for DC/DC converter.

● Ordering Information

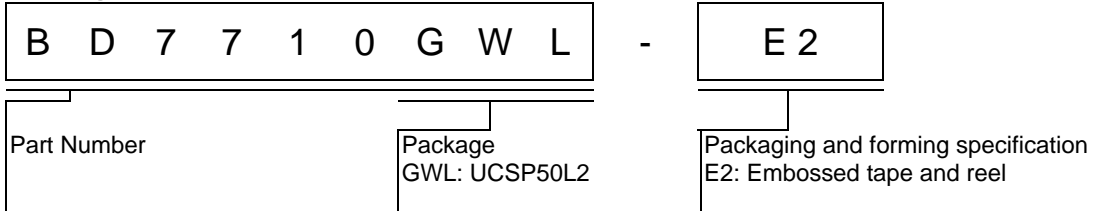

UCSP50L2 (BD7710GWL) -Packing specification-

Tape	Embossed carrier tape
Quantity	3,000pcs/Reel
Direction of feed	E2

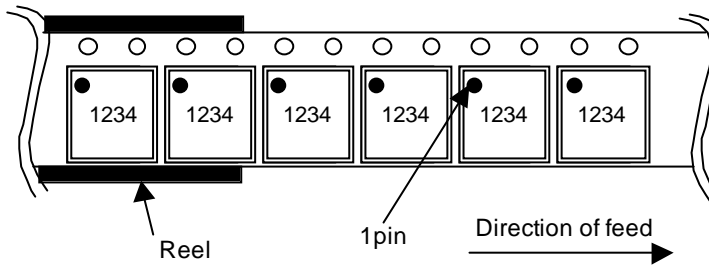

Figure 34. Typical Tape and Reel configuration

● Marking Diagram

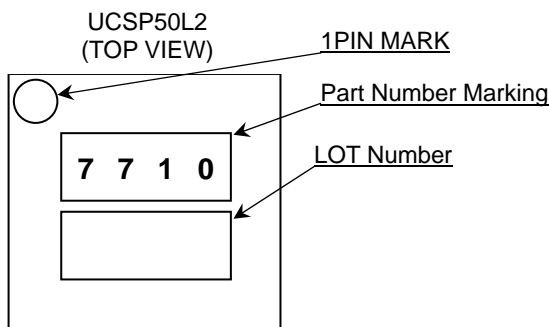
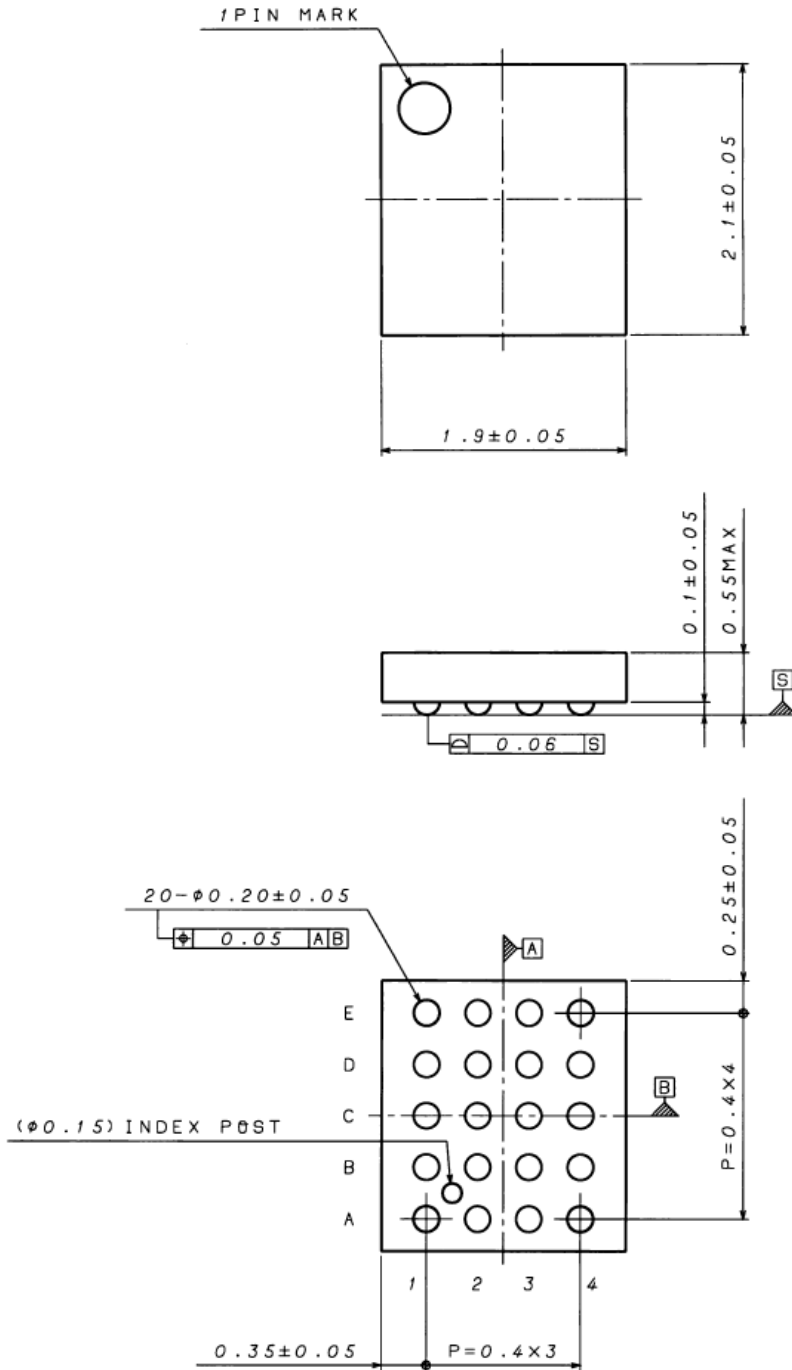

Figure 35. Marking Diagram

●Package

20Pin UCSP50L2 CSP small package  
 SIZE : 1.90mm x 2.10mm  
 A ball pitch : 0.4mm  
 Height : 0.55mm max



(UNIT: mm)

Figure 36. Package size

## ●Revision History

Date	Revision	Changes
5.December.2012	001	New Release
30.January.2013	002	<p>P22 Additional page about DC/DC operation</p> <p>P10,11,21,23,24,25,26,27,28,29,31,34,35 Figure Numbering is updated.</p> <p>P23,24,25,26,27,28 Title Numbering is updated.</p> <p>P1 Additional items about Key Specifications.</p> <p>P1 About General Description, explanation is updated.</p> <p>P2 About Storage Temperature Range: Value is changed.</p> <p>P2 Parameter name of Electrical characteristics is changed.</p> <p>P3 Terminals Description is updated.</p> <p>P5 Y-axis name of the table is updated</p> <p>P7 Figure name is updated.</p> <p>P12 Function explanation is updated.</p> <p>P17 Title is updated.</p> <p>P17 About bit[4] ILIM, explanation is updated.</p> <p>P18. Title modification. "Address 05" -&gt; "Address 05h"</p> <p>About bit6 ENPSM, expression style is changed.</p> <p>P19 Title modification.</p> <p>About bit[3:0]OVP, explanation is updated.</p> <p>About bit5 LEDWARN, explanation is updated.</p> <p>About bit6 LEDHOT, explanation is updated.</p> <p>About bit7 ENTS, explanation is added.</p> <p>P20 Title modification. "Address 07" -&gt; "Address 07h"</p> <p>P21 About "Reset sequence", explanation is updated.</p> <p>P27 About "Over Current Protection", explanation is updated.</p> <p>P27 About "VOUT Short Protection", title is changed.</p> <p>P28 About "Battery drop Protection", Figure name is changed.</p> <p>P32 About Power supply line, explanation is updated.</p>
20.May.2013	003	P4 Change Black Diagram

# Notice

## Precaution on using ROHM Products

- Our Products are designed and manufactured for application in ordinary electronic equipments (such as AV equipment, OA equipment, telecommunication equipment, home electronic appliances, amusement equipment, etc.). If you intend to use our Products in devices requiring extremely high reliability (such as medical equipment <sup>(Note 1)</sup>, transport equipment, traffic equipment, aircraft/spacecraft, nuclear power controllers, fuel controllers, car equipment including car accessories, safety devices, etc.) and whose malfunction or failure may cause loss of human life, bodily injury or serious damage to property ("Specific Applications"), please consult with the ROHM sales representative in advance. Unless otherwise agreed in writing by ROHM in advance, ROHM shall not be in any way responsible or liable for any damages, expenses or losses incurred by you or third parties arising from the use of any ROHM's Products for Specific Applications.

(Note1) Medical Equipment Classification of the Specific Applications

JAPAN	USA	EU	CHINA
CLASS III	CLASS III	CLASS II b	CLASS III
CLASS IV		CLASS III	

- ROHM designs and manufactures its Products subject to strict quality control system. However, semiconductor products can fail or malfunction at a certain rate. Please be sure to implement, at your own responsibilities, adequate safety measures including but not limited to fail-safe design against the physical injury, damage to any property, which a failure or malfunction of our Products may cause. The following are examples of safety measures:
  - Installation of protection circuits or other protective devices to improve system safety
  - Installation of redundant circuits to reduce the impact of single or multiple circuit failure
- Our Products are designed and manufactured for use under standard conditions and not under any special or extraordinary environments or conditions, as exemplified below. Accordingly, ROHM shall not be in any way responsible or liable for any damages, expenses or losses arising from the use of any ROHM's Products under any special or extraordinary environments or conditions. If you intend to use our Products under any special or extraordinary environments or conditions (as exemplified below), your independent verification and confirmation of product performance, reliability, etc. prior to use, must be necessary:
  - Use of our Products in any types of liquid, including water, oils, chemicals, and organic solvents
  - Use of our Products outdoors or in places where the Products are exposed to direct sunlight or dust
  - Use of our Products in places where the Products are exposed to sea wind or corrosive gases, including Cl<sub>2</sub>, H<sub>2</sub>S, NH<sub>3</sub>, SO<sub>2</sub>, and NO<sub>2</sub>
  - Use of our Products in places where the Products are exposed to static electricity or electromagnetic waves
  - Use of our Products in proximity to heat-producing components, plastic cords, or other flammable items
  - Sealing or coating our Products with resin or other coating materials
  - Use of our Products without cleaning residue of flux (even if you use no-clean type fluxes, cleaning residue of flux is recommended); or Washing our Products by using water or water-soluble cleaning agents for cleaning residue after soldering
  - Use of the Products in places subject to dew condensation
- The Products are not subject to radiation-proof design.
- Please verify and confirm characteristics of the final or mounted products in using the Products.
- In particular, if a transient load (a large amount of load applied in a short period of time, such as pulse. is applied, confirmation of performance characteristics after on-board mounting is strongly recommended. Avoid applying power exceeding normal rated power; exceeding the power rating under steady-state loading condition may negatively affect product performance and reliability.
- De-rate Power Dissipation (Pd) depending on Ambient temperature (Ta). When used in sealed area, confirm the actual ambient temperature.
- Confirm that operation temperature is within the specified range described in the product specification.
- ROHM shall not be in any way responsible or liable for failure induced under deviant condition from what is defined in this document.

## Precaution for Mounting / Circuit board design

- When a highly active halogenous (chlorine, bromine, etc.) flux is used, the residue of flux may negatively affect product performance and reliability.
- In principle, the reflow soldering method must be used; if flow soldering method is preferred, please consult with the ROHM representative in advance.

For details, please refer to ROHM Mounting specification

**Precautions Regarding Application Examples and External Circuits**

1. If change is made to the constant of an external circuit, please allow a sufficient margin considering variations of the characteristics of the Products and external components, including transient characteristics, as well as static characteristics.
2. You agree that application notes, reference designs, and associated data and information contained in this document are presented only as guidance for Products use. Therefore, in case you use such information, you are solely responsible for it and you must exercise your own independent verification and judgment in the use of such information contained in this document. ROHM shall not be in any way responsible or liable for any damages, expenses or losses incurred by you or third parties arising from the use of such information.

**Precaution for Electrostatic**

This Product is electrostatic sensitive product, which may be damaged due to electrostatic discharge. Please take proper caution in your manufacturing process and storage so that voltage exceeding the Products maximum rating will not be applied to Products. Please take special care under dry condition (e.g. Grounding of human body / equipment / solder iron, isolation from charged objects, setting of Ionizer, friction prevention and temperature / humidity control).

**Precaution for Storage / Transportation**

1. Product performance and soldered connections may deteriorate if the Products are stored in the places where:
  - [a] the Products are exposed to sea winds or corrosive gases, including Cl<sub>2</sub>, H<sub>2</sub>S, NH<sub>3</sub>, SO<sub>2</sub>, and NO<sub>2</sub>
  - [b] the temperature or humidity exceeds those recommended by ROHM
  - [c] the Products are exposed to direct sunshine or condensation
  - [d] the Products are exposed to high Electrostatic
2. Even under ROHM recommended storage condition, solderability of products out of recommended storage time period may be degraded. It is strongly recommended to confirm solderability before using Products of which storage time is exceeding the recommended storage time period.
3. Store / transport cartons in the correct direction, which is indicated on a carton with a symbol. Otherwise bent leads may occur due to excessive stress applied when dropping of a carton.
4. Use Products within the specified time after opening a humidity barrier bag. Baking is required before using Products of which storage time is exceeding the recommended storage time period.

**Precaution for Product Label**

QR code printed on ROHM Products label is for ROHM's internal use only.

**Precaution for Disposition**

When disposing Products please dispose them properly using an authorized industry waste company.

**Precaution for Foreign Exchange and Foreign Trade act**

Since our Products might fall under controlled goods prescribed by the applicable foreign exchange and foreign trade act, please consult with ROHM representative in case of export.

**Precaution Regarding Intellectual Property Rights**

1. All information and data including but not limited to application example contained in this document is for reference only. ROHM does not warrant that foregoing information or data will not infringe any intellectual property rights or any other rights of any third party regarding such information or data. ROHM shall not be in any way responsible or liable for infringement of any intellectual property rights or other damages arising from use of such information or data.:
2. No license, expressly or implied, is granted hereby under any intellectual property rights or other rights of ROHM or any third parties with respect to the information contained in this document.

**Other Precaution**

1. This document may not be reprinted or reproduced, in whole or in part, without prior written consent of ROHM.
2. The Products may not be disassembled, converted, modified, reproduced or otherwise changed without prior written consent of ROHM.
3. In no event shall you use in any way whatsoever the Products and the related technical information contained in the Products or this document for any military purposes, including but not limited to, the development of mass-destruction weapons.
4. The proper names of companies or products described in this document are trademarks or registered trademarks of ROHM, its affiliated companies or third parties.

**General Precaution**

1. Before you use our Products, you are requested to carefully read this document and fully understand its contents. ROHM shall not be in any way responsible or liable for failure, malfunction or accident arising from the use of any ROHM's Products against warning, caution or note contained in this document.
2. All information contained in this document is current as of the issuing date and subject to change without any prior notice. Before purchasing or using ROHM's Products, please confirm the latest information with a ROHM sales representative.
3. The information contained in this document is provided on an "as is" basis and ROHM does not warrant that all information contained in this document is accurate and/or error-free. ROHM shall not be in any way responsible or liable for any damages, expenses or losses incurred by you or third parties resulting from inaccuracy or errors of or concerning such information.

## X-ON Electronics

Largest Supplier of Electrical and Electronic Components

*Click to view similar products for [LED Lighting Drivers](#) category:*

*Click to view products by [ROHM](#) manufacturer:*

Other Similar products are found below :

[LV5235V-MPB-H](#) [MB39C602PNF-G-JNEFE1](#) [MIC2871YMK-T5](#) [AL1676-10BS7-13](#) [AL1676-20AS7-13](#) [AP5726WUG-7](#) [ICL8201](#)  
[IS31BL3228B-UTLS2-TR](#) [IS31BL3506B-TTLS2-TR](#) [AL3157F-7](#) [AP5725FDCG-7](#) [LV52204MTTBG](#) [AP5725WUG-7](#) [STP4CMPQTR](#)  
[NCL30086BDR2G](#) [CAT4004BHU2-GT3](#) [LV52207AXA-VH](#) [AP1694AS-13](#) [TLE4242EJ](#) [KTD2027EWE-TR](#) [AS3688](#) [IS31LT3172-GRLS4-TR](#) [TLD2311EL](#) [KTD2694EDQ-TR](#) [KTZ8864EJAA-TR](#) [IS32LT3174-GRLA3-TR](#) [MP2488DN-LF-Z](#) [NLM0010XTSA1](#) [AL1676-20BS7-13](#)  
[ZXLD1370QESTTC](#) [MPQ7220GF-AEC1-P](#) [MPQ7220GR-AEC1-P](#) [MPQ4425BGJ-AEC1-P](#) [MPQ7220GF-AEC1-Z](#) [MPQ4425BGJ-AEC1-Z](#)  
[IS31FL3737B-QFLS4-TR](#) [IS31FL3239-QFLS4-TR](#) [KTD2058EUAC-TR](#) [KTD2037EWE-TR](#) [DIO5662ST6](#) [KTD2026BEWE-TR](#)  
[MAX20052CATC/V+](#) [MAX25606AUP/V+](#) [BD6586MUV-E2](#) [BD9206EFV-E2](#) [LYT4227E](#) [LYT6079C-TL](#) [MP3394SGF-P](#) [MP4689AGN-P](#)  
[MPQ4425AGQB-AEC1-Z](#)