

1.5A LED Camera Flash Driver Synchronous Rectification Step-Up DC/DC

BD7757MWX

General Description

The BD7757MWX is a 1.5A Flash LED Driver with Synchronous rectification step up DC/DC converter that can drive 1LED. The LED current, timer, and UVLO threshold can be varied by using UPIC++ (Uni-Port Interface Control ++).

Features

- Synchronous rectification step-up DC/DC converter.
- Control of registers via Uni-Port Interface Control ++ (UPIC)
- Maximum current of 1.5A in Flash mode (Low side LED Driver).
- Lighting Mode Setup
 - Flash Mode...1.5A (Max)
 - Torch Mode...450mA (Max)
- Variable LED current
- Protection Circuit:
 - Over Current Protection Circuit (OCP)
 - Over Voltage Protection Circuit (OVP)
 - VOUT – GND Short Protection Circuit
 - LED Short / Open Protection Circuit
 - Under Voltage Lock Out Circuit (UVLO)
 - Thermal Shut Down Circuit (TSD)
 - Battery Drop Protection Circuit
 - Flash Timer Protection Circuit

Applications

- Flash LED Driver for camera and smart phone
- DSC, DVC
- Video Lighting for Digital Video Applications
- Amusement accessory

Key Specifications

- Input Voltage Range : 2.7V to 5.0V
- LED current (FLASH): 1.5A (Max)
- LED current (TORCH): 450mA (Max)
- Switching Frequency : 2MHz (Typ)
- Pch FET On Resistance : 150mΩ (Typ)
- Nch FET On Resistance : 100mΩ (Typ)
- Standby Current at shut down : 0μA (Typ)
- Operating Temperature Range: -30°C to +85°C

Package

USON014X3020

W(Typ.) x D(Typ.) x H(Max.)
3.00mm x 2.00mm x 0.60mm

Pin Configuration

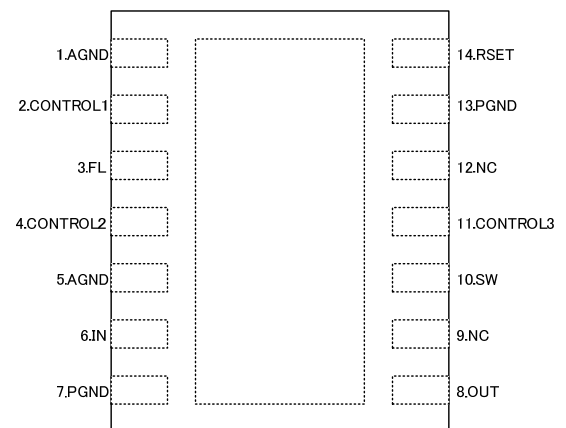

Figure 2. Pin Configuration

Typical Application Circuit

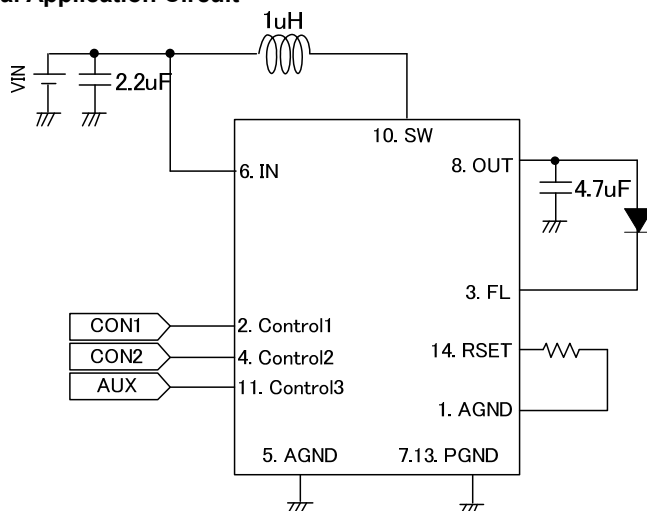

Figure 1. Application Circuit

Pin Description

Terminal No.	Pin Name	In/ Out	ESD Diode		Function
			For Power	For GND	
1	AGND	-	-	-	Ground
2	CONTROL1	In	-	GND	UPIC++ control input
3	FL	Out	-	GND	Flash/Torch current output
4	CONTROL2	In	-	GND	Flash ON/OFF terminal. (Compulsive lighting, even if control1=Low state. Output flash current set with initial state at control1=Low state.)
5	AGND	-	-	-	Ground
6	IN	In	-	GND	Power supply
7	PGND	-	-	-	Power ground
8	OUT	Out	-	GND	DCDC output voltage
9	NC	-	-	-	No connection
10	SW	In	-	GND	Switching output
11	CONTROL3	In	-	GND	Flash ON/OFF terminal. (Compulsive lighting, even if control1=Low state. Output flash current set with initial state at control1=Low state.)
12	NC	-	-	-	No connection
13	PGND	-	-	-	Power ground
14	RSET	Out	-	GND	The resistor connection terminal of output LED current setting.

Block Diagram

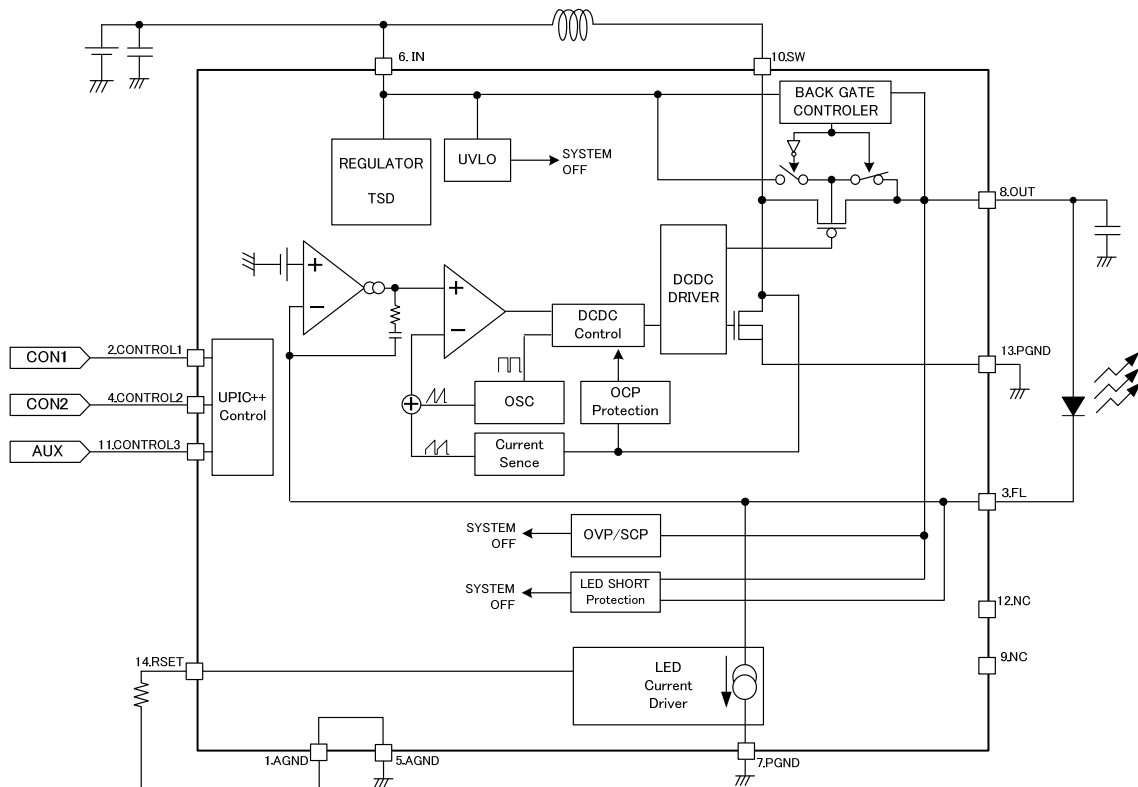

Figure 3. Block Diagram

Absolute Maximum Ratings

Parameter	Symbol	Limit	Unit
Input voltage [All Terminal]	V _{MAX}	7	V
Power Dissipation	P _d	1.75 ^(*)	W
Operating Temperature Range	Topr	-30 to +85	°C
Storage Temperature	Tstg	-55 to +150	°C

*1 Derate by 14mW/°C when operating above 25°C (Mount on 2-layer board)

Recommended Operating Conditions

Parameter	Symbol	Limit	Unit
Supply Voltage	V _{IN}	2.7 to 5.0	V
Maximum Output Current in Flash Mode	I _{FLED_MAX}	1.5	A
Maximum Output Current in Torch Mode	I _{TLED_MAX}	450	mA

Electrical Characteristics (Unless otherwise specified, Ta = +25°C, V_{BAT}=3.6V)

Parameter	Symbol	Min.	Typ.	Max.	Unit	Conditions
Logic controller						
Low Threshold Voltage	V _{IL}	-0.3	-	0.4	V	CONTROL1,2,3
High Threshold Voltage	V _{IH}	1.4	-	5.2	V	CONTROL1,2,3
CONTROLx=High Input Current	I _{FH}	-	36	70	μA	CONTROL1,2,3=3.6V
CONTROLx=Low Input Current	I _{FL}	-1	0	1	μA	CONTROL1,2,3=0V
Control1 High Time	t _{HI}	1	-	100	μs	
Control1 Low Time	t _{LO}	1	-	100	μs	
Access Available Time	t _{ACC}	-	-	500	μs	
Control1 Off Timeout	t _{OFF}	-	-	500	μs	
Latch Time	t _{LAT}	-	-	1	ms	
Others						
Quiescent Current	I _Q	-	0.1	2.0	μA	
Current Consumption	I _{DD1}	-	3.0	-	mA	I _{LED} =100mA
SW NMOS On Resistance	R _{ONN}	-	0.10	-	Ω	V _{IN} =3.6V, at 200mA
SW PMOS On Resistance	R _{ONP}	-	0.15	-	Ω	V _{OUT} =3.6V at 200mA
Inductor Current Limit	I _{COIL}	-	3	-	A	This parameter is tested in dc measurement.
Switching Frequency	f _{SW}	1.6	2	2.4	MHz	
Duty Cycle Limit	Duty	50	80	-	%	V _{HR} =0.0V
Output Voltage Range	V _O	-	-	5.1	V	
Over Voltage Protection Limit	V _{OV}	-	5.4	5.7	V	V _{HR} =0.0V
LED Short Threshold Voltage	V _{STV}	1.5	1.7	1.9	V	(V _{OUT} -V _{FL}) =SWEEP UP
LED Test Current during LED Short Protect	I _{TLED}	1	2	3	mA	V _{FL} =2V
Headroom Voltage	V _{HR}	0.18	0.23	0.28	V	At step up condition
Torch LED Current Accuracy	I _{T-DIFF}	-10	0	10	%	I _{LED} =100mA
Flash LED Current Accuracy	I _{F-DIFF1}	-10	0	10	%	I _{LED} =1.0A
UVLO Cancel Voltage	V _{UVLO}	2.4	2.5	2.6	V	V _{IN} Sweep Up
UVLO Hysteresis Voltage	V _{UVLO_HYS}	0.2	0.3	0.4	V	V _{IN} Sweep Down

Typical Performance Curves

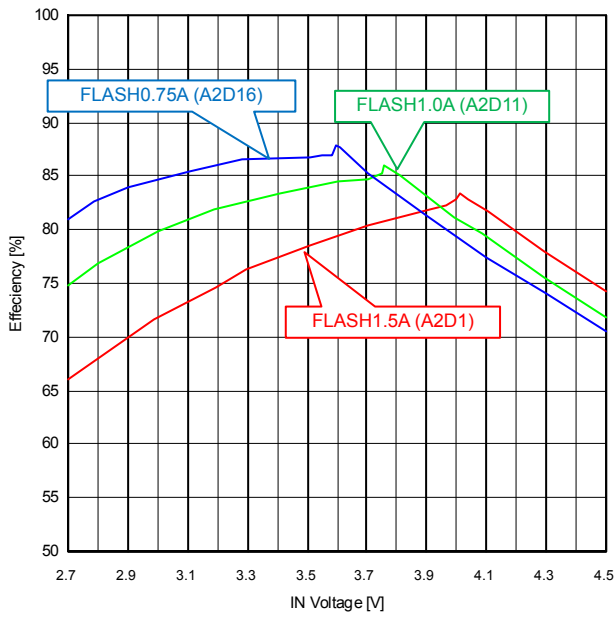

Figure 4. Efficiency [%] vs. IN Voltage [V] (Flash Mode)

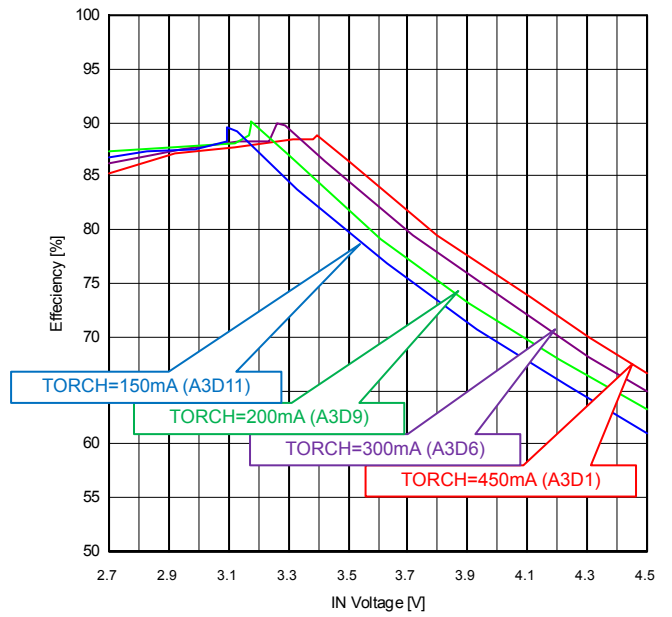

Figure 5. Efficiency [%] vs. IN Voltage [V] (Torch Mode)

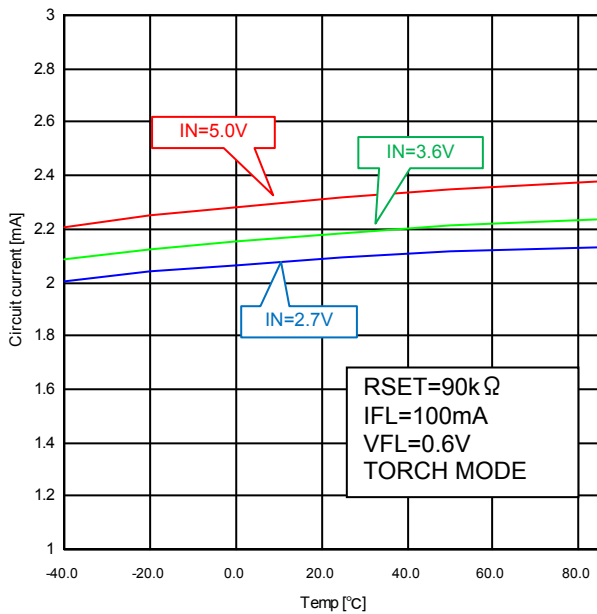

Figure 6. Circuit Current [mA] vs. Temperature [°C]

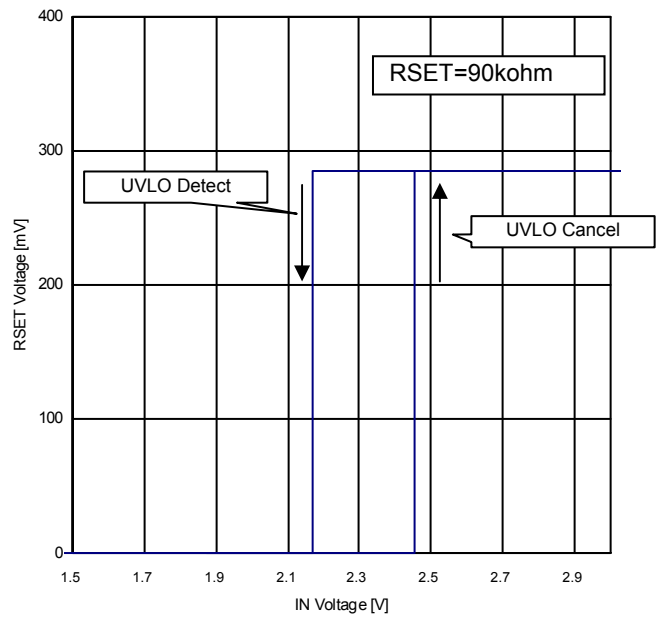

Figure 7. RSET Voltage [V] vs. IN Voltage [V]

Typical Performance Curves - continued

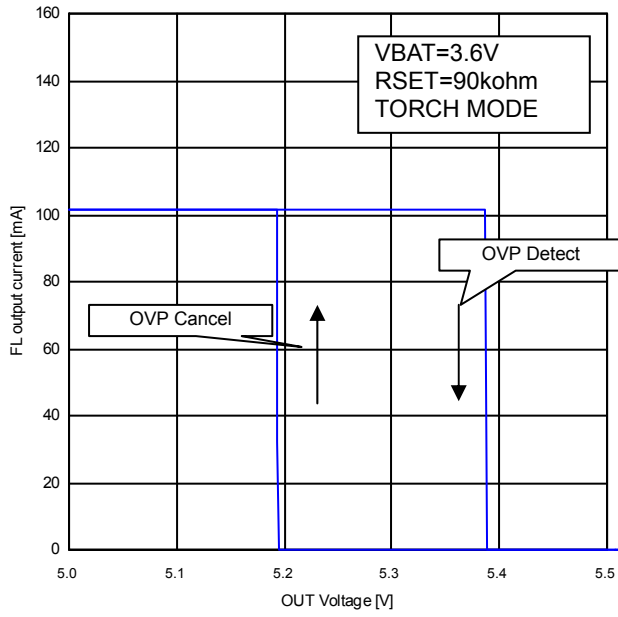

Figure 8. FL output current [A] vs. OUT Voltage [V]

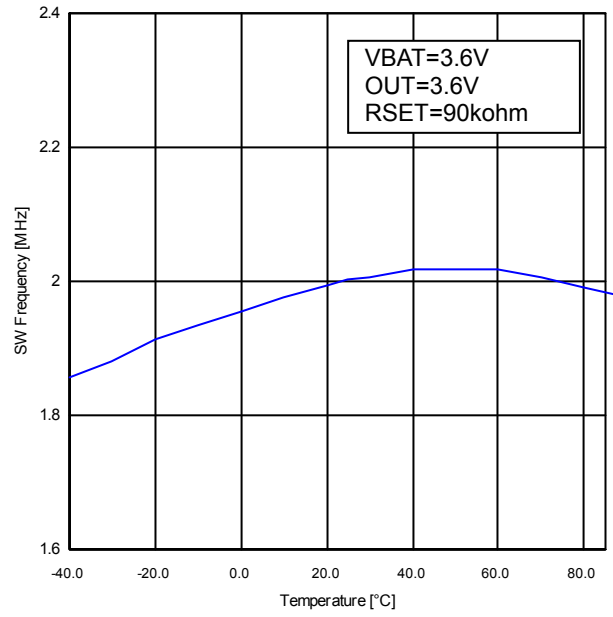

Figure 9. SW Frequency [MHz] vs. Temperature [°C]

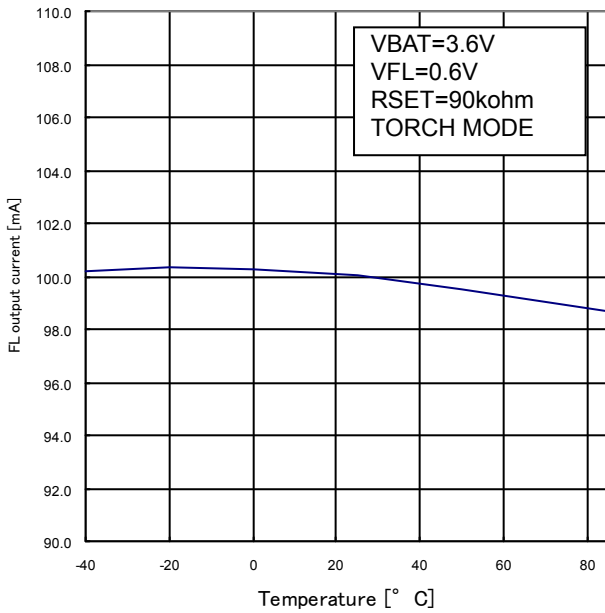

Figure 10. FL output current [mA] vs. Temperature [°C] at TORCH 100mA

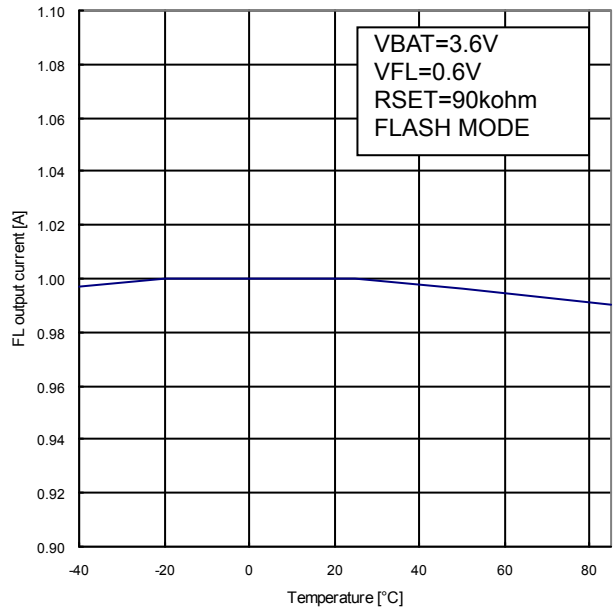

Figure 11. FL output current [A] vs. Temperature [°C] at FLASH 1.0A

Functional Description

1. Maximum Flash Current setup

The maximum Flash current can be set by varying the value of RSET which is connected to RSET-GND terminal.
The resistor value can be calculated using the equation:

$$\text{Flash current} = \frac{1.0 \text{ A} \times 90 \text{ k}\Omega}{\text{RSET}}$$

1-1 Maximum Flash Current Setup

RSET	Flash Current
60 kΩ	I _{LED} = 1.5A
75 kΩ	I _{LED} = 1.2A
90 kΩ	I _{LED} = 1.0A

If RSET is set less than 36kΩ (typ.), the LED current is stopped by internal ISET short limit circuit.

2. Register control

Flash-to-Torch ratio can be controlled by the 16-data register. The on/off control of LED current, the Flash timer, the LED current threshold at timer start and the low battery detect can also be set through the register.

Register Map is as follows;

(N: number of edges)

2-1 Address Map (Initial Address = 1)

N	Address	Addressed register	Data	Initial Data
1	1	Select Torch/FLASH mode. Select Inhibit/AUX	1-3 4- 5	1 (POFF)
2	2	FLASH current setting	1-16	1 (1.0A at RSET=90k)
3	3	TORCH current setting	1-16	11 (100mA at RSET=90k)
4	4	LED timer setting	1-16	10 (1000ms)
5	5	LED current threshold at timer start	1-8	6 (300mA)
6	6	Low Battery detection setting	1-10	10 (No detect)

2-2 Address Description

Address 1 : LED Mode

N	Data	Symbol	Mode Description
13	1 *	POFF	Power OFF
14	2	TON	Torch ON
15	3	FON	Flash ON
16	4	FINH	Inhibit ON
17	5	AUX	AUX ON

(n≥18, NOP)

POFF...STOP LED and DCDC output.

FINH...Mode changes to torch mode correspondingly

AUX...Flash mode turns ON compulsorily with initial data (data=1)

* Initial Data = 1

Address 2, : Flash Current Ratio

Flash current = Maximum Flash current × Fratio

N	Data	Fratio	RSET =60kΩ	RSET =90kΩ
13	1 *	100.0%	1500mA	1000mA
14	2	96.7%	1450mA	967mA
15	3	93.3%	1400mA	933mA
16	4	90.0%	1350mA	900mA
17	5	86.7%	1300mA	867mA
18	6	83.3%	1250mA	833mA
19	7	80.0%	1200mA	800mA
20	8	76.7%	1150mA	767mA
21	9	73.3%	1100mA	733mA
22	10	70.0%	1050mA	700mA
23	11	66.7%	1000mA	667mA
24	12	63.3%	950mA	633mA
25	13	60.0%	900mA	600mA
26	14	56.7%	850mA	567mA
27	15	53.3%	800mA	533mA
28	16	50.0%	750mA	500mA

(n≥29, NOP)

* Initial Data = 1

Functional Description – continued

Address 3 : Torch Current Ratio

Torch current =Maximum Torch current × Tratio

N	Data	Tratio	RSET =60kΩ	RSET =90kΩ
13	1	100.0%	450mA	300mA
14	2	93.3%	420mA	280mA
15	3	86.7%	390mA	260mA
16	4	80.0%	360mA	240mA
17	5	73.3%	330mA	220mA
18	6	66.7%	300mA	200mA
19	7	60.0%	270mA	180mA
20	8	53.3%	240mA	160mA
21	9	46.7%	210mA	140mA
22	10	40.0%	180mA	120mA
23	11 *	33.3%	150mA	100mA
24	12	26.7%	120mA	80mA
25	13	20.0%	90mA	60mA
26	14	13.3%	60mA	40mA
27	15	6.7%	30mA	20mA
28	16	0%	0.0mA	0.0mA

(n≥29, NOP)

* Initial Data = 11

Address 4 : Flash Timer

N	Data	Flash Timer
13	1	20ms
14	2	40ms
15	3	60ms
16	4	80ms
17	5	100ms
18	6	200ms
19	7	400ms
20	8	600ms
21	9	800ms
22	10 *	1000ms
23	11	1200ms
24	12	1400ms
25	13	1600ms
26	14	1800ms
27	15	2000ms
28	16	Timer off

(n≥29, NOP)

* Initial Data = 10

Address 5: LED Current Threshold at Timer Start

N	Data	LED current threshold at timer start
13	1	400mA
14	2	350mA
15	3 *	300mA
16	4	250mA
17	5	200mA
18	6	150mA
19	7	100mA
20	8	50mA

(n≥21, NOP)

* Initial Data = 3

Address 6: Low Battery Detection

N	Data	Battery voltage
13	1	3.8
14	2	3.7
15	3	3.6
16	4	3.5
17	5	3.4
18	6	3.3
19	7	3.2
20	8	3.0
21	9	2.8
22	10 *	No detect

(n≥23, NOP)

* Initial Data = 10

Functional Description – continued

3. Register Access Control Protocol

LED current is controlled through the Control1 terminal whose input is from the uni-Port interface. The register can be accessed by using the protocol below.

(The first rising edge to Control1 from the time of shutdown is not included in address and data assignment.)

oAddress / Data Selection Waveform

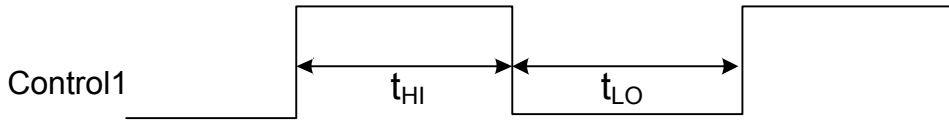

Figure 13. Control1 Signal Timing Diagram

item	MIN	MAX
High input time (t _{HI})	1us	100us
Low input time (t _{LO})	1us	100us

oExample : Address = 3 · Data = 8 (changes FLASH current to 53.3%)

This edge is not counted for “n”.

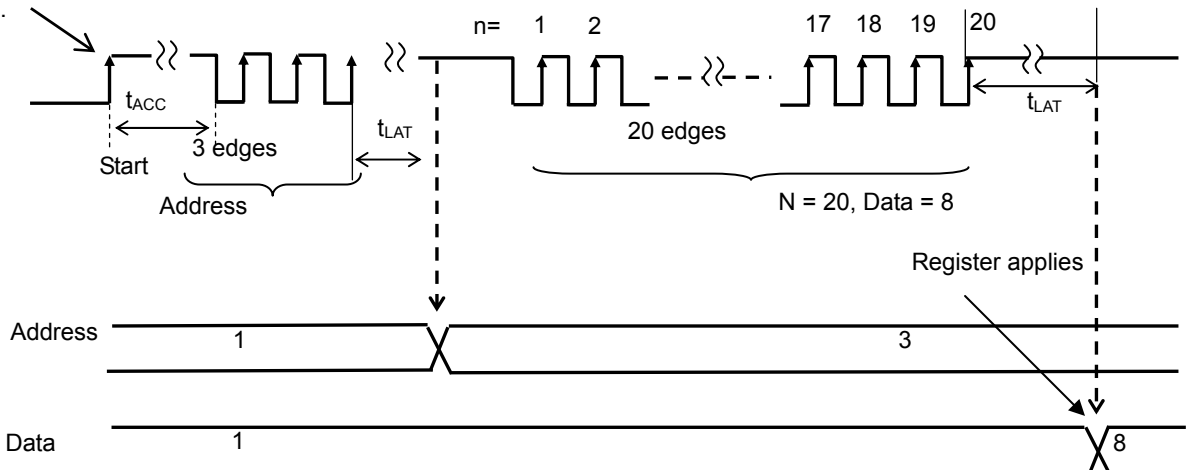

Figure 14. Example of Control1 Signal

After the UVLO circuit is triggered, all register settings are reset. Hence, the registers has to be set again once UVLO circuit is cancelled (VBAT>2.5V) *.

*Please refer to “Electrical Characteristics” on P.3 for the specification on each symbol.

4. Startup and Shut Down Sequence

○Example of FLASH action using control1.

1. After power up of IN terminal, input signal to control1.
2. If none of the protection circuit is enabled, VOUT starts charging after sending the Flash or Torch lighting signal.
3. Test current (2mA, typ.) is loaded from FL current when it reaches $V_{OUT} > V_{IN} - 0.25V$. At that time, output FL current, if STV is not detected yet, Soft Start (SS:IC built-in circuit) starts to charger..
4. DCDC completes boost up and LED current is stable.
5. Setting Control1=L turns off the IC after t_{OFF} time.

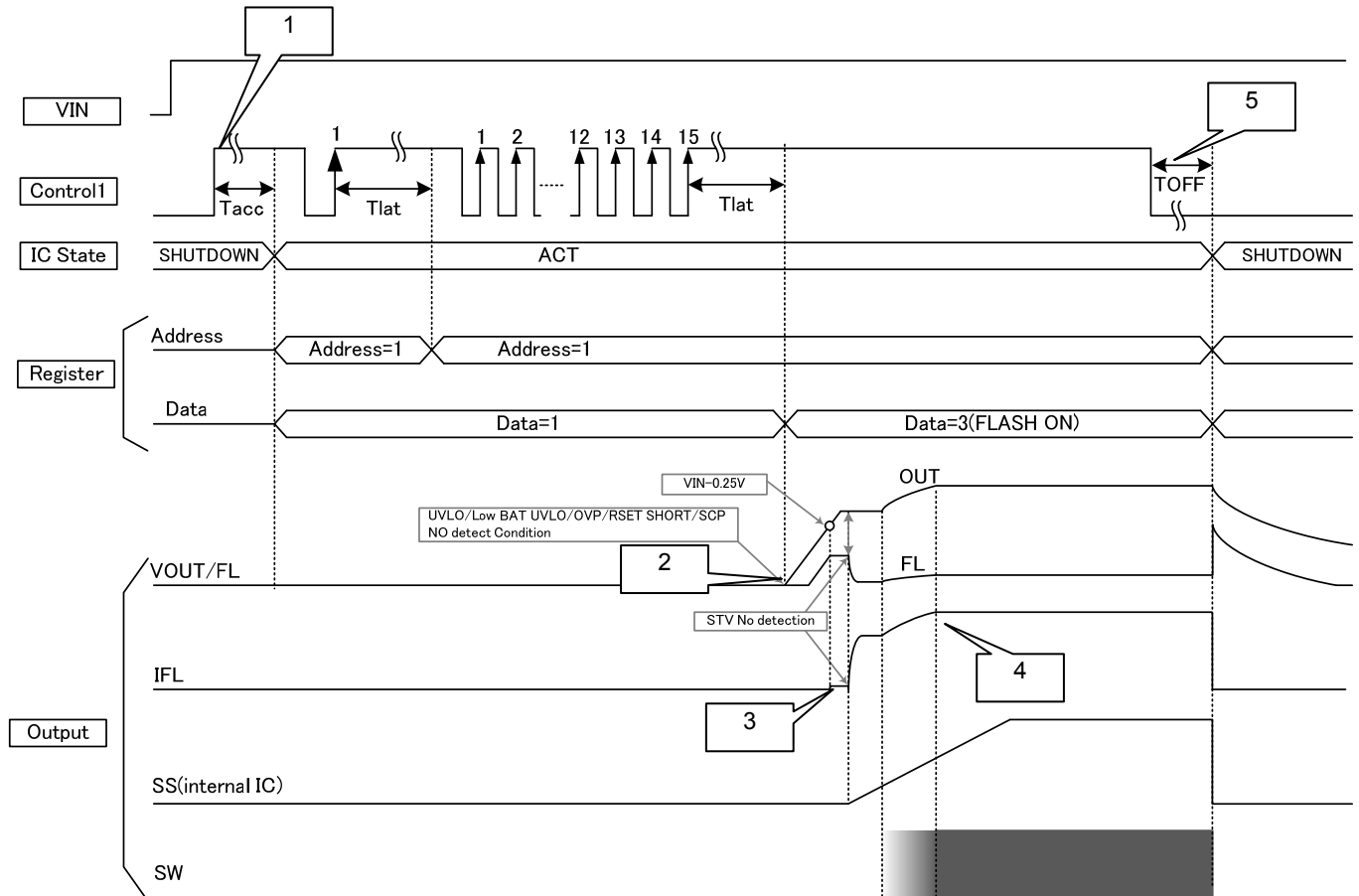

Figure 15. Startup and Shut down Sequence using Control1

OFLASH Action using Control2 or Control3

1. After power up of IN terminal, input signal to control1 and next input control2 or control3. Set condition by Control1, before input control2 or control3.
2. If none of the protection circuit is enabled, VOUT starts charging.
3. Test current (2mA, typ.) is loaded from FL current when it reaches $V_{OUT} > V_{IN} - 0.25V$. At that time, output FL current, if STV is not detected yet, Soft Start (SS:IC built-in circuit) starts to charger..
4. DCDC completes boost up and LED current is stable.
5. Setting Control2,3=L turns off the IC after t_{OFF} Time

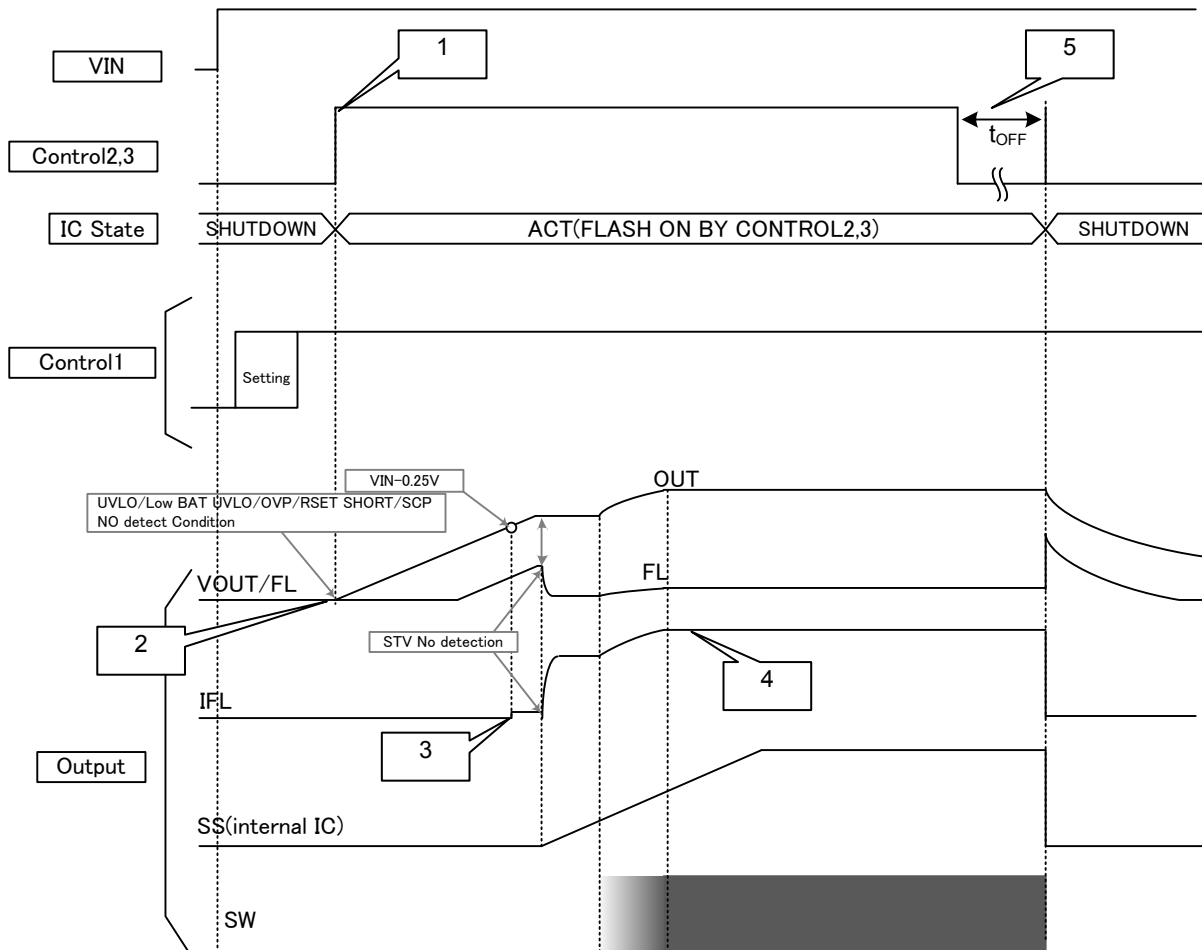

Figure 16. Startup and Shut Down Sequence using Control2 or Control3

*Startup in Flash operation by Control2 or 3=H and Control1=Low state, Control1 cannot receive signal.

Therefore, when setting change is assumed during the compulsive flash operation by control2 or 3, first of all, please input anything signal into control1 (for keeping control1=H state). And control1 becomes possible receiving the signal also during the compulsive FLASH operation by setting control2 or 3=High state.

5. Flash or Torch Mode Selection

Switching between Flash and Torch mode can be done using Control1, 2 or 3

Control terminal name	Input signal	Function
Control1	A1/D1	LED/DCDC=OFF
	A1/D2	Torch Mode
	A1/D3	Flash Mode
	A1/D4	Forcibly changes to Torch Mode (FINH)
	A1/D5	FLASH turn ON forcibly with initial data (AUX)
Control2*	High	Forced Flash lighting (output in address/data assigned current) Forced Flash even when Control1=Low state
Control3*	High	Forced Flash lighting (output in address/data assigned current) Forced Flash even when Control1=Low state

※Control2,3 are the same function

OPriority number of FLASH/TORCH selection

Priority 1	Priority 2	Priority 3	Priority 4
Control1 : A1/D4 (FINH) Compulsive TORCH operation	Control2 Compulsive FLASH operation	Control1 : A1/D5 (AUX) Compulsive FLASH operation with initial condition data	Control1 : A1/D2 (TORCH operation)
	Control3 Compulsive FLASH operation		Control1 : A1/D3 (FLASH operation)

For example, when specifying A1/D4 by Control1 and switching to TORCH mode,
TORCH state is continued even if Control3=High

6. Regarding LED output current

FLASH Control

When the setting changes to Flash mode, the maximum output current can be set up to 1.5A

The control method for setting FLASH mode

Control terminal name	Input signal	Control Function
Control1	A1/D3	FLASH mode
	A1/D5	FLASH turn ON forcibly with initial data (AUX)
Control2	High	Forced Flash lighting (output in address/data assigned current) Forced Flash even when Control1=Low state
Control3	High	Forced Flash lighting (output in address/data assigned current) Forced Flash even when Control1=Low state

If the setting continues to send high current to the LED for an extended period of time, it will generate heat to the IC and will cause lower luminance. In order to prevent this, FLASH TIMER function is built in and that time can be changed by setting the register (Typ 1.0s).

Please refer to the maximum LED current specification (p.6) and set up LED timer (p.7).

OLED Timer Function

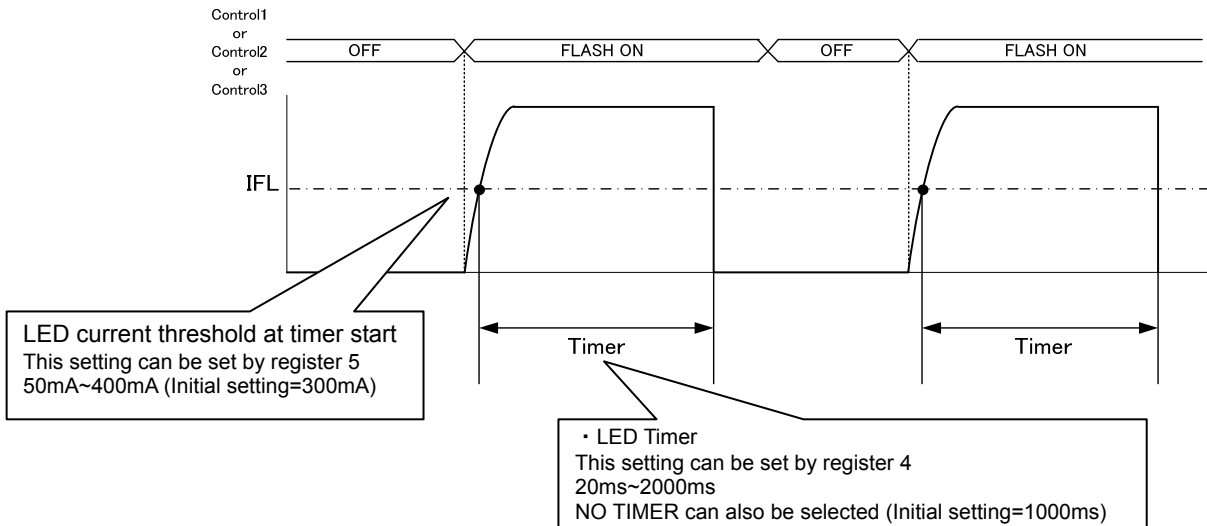

Figure 17. Timer Operation 1

By setting the register, BD7757MWX can change the LED current threshold at timer start and the LED timer. Timer operation is applicable in both Flash and Torch mode.

When the light on the LED's turn off because the timer finished, the following sequences are required in order to make the light re-switch back on.

- Re-lighting by control1

1. Input Address=1/Data=1 -> turn off LED/DCDC operation. -> Input Re-lighting signal.
2. Control1= Low during TOFF -> input re-start signal

- Re-lighting by control2 or control3

1. Control2 or control3=Low -> Input Control2 or control3=Low→High.

Counter is reset when LED current crosses the threshold during a timer count. While, when LED current goes over the LED current threshold, it counts back from the start.

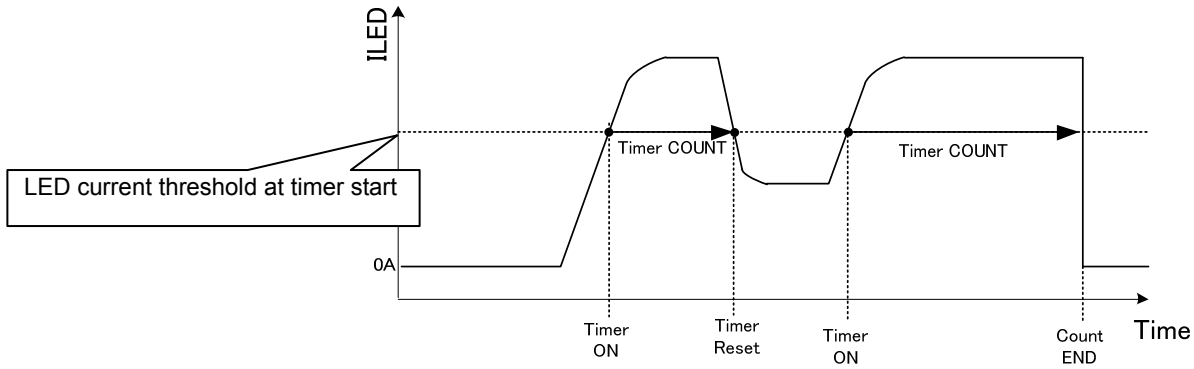

Figure 18. Timer Operation 2

Moreover, Counter is reset when LED current is set to turn off by control1,2 or 3 during a count.

OF forced Flash (Control2,3)

Flash is turned on forcibly by sending a high signal to Control2 or Control3 (Control2 and control3 are of the same function). During Flash mode, LED's can be turned off by control2 or control3 by

- Control2 or control3=Low
- Timer END

The sequence of FLASH operation by control2 or control 3 is shown below.

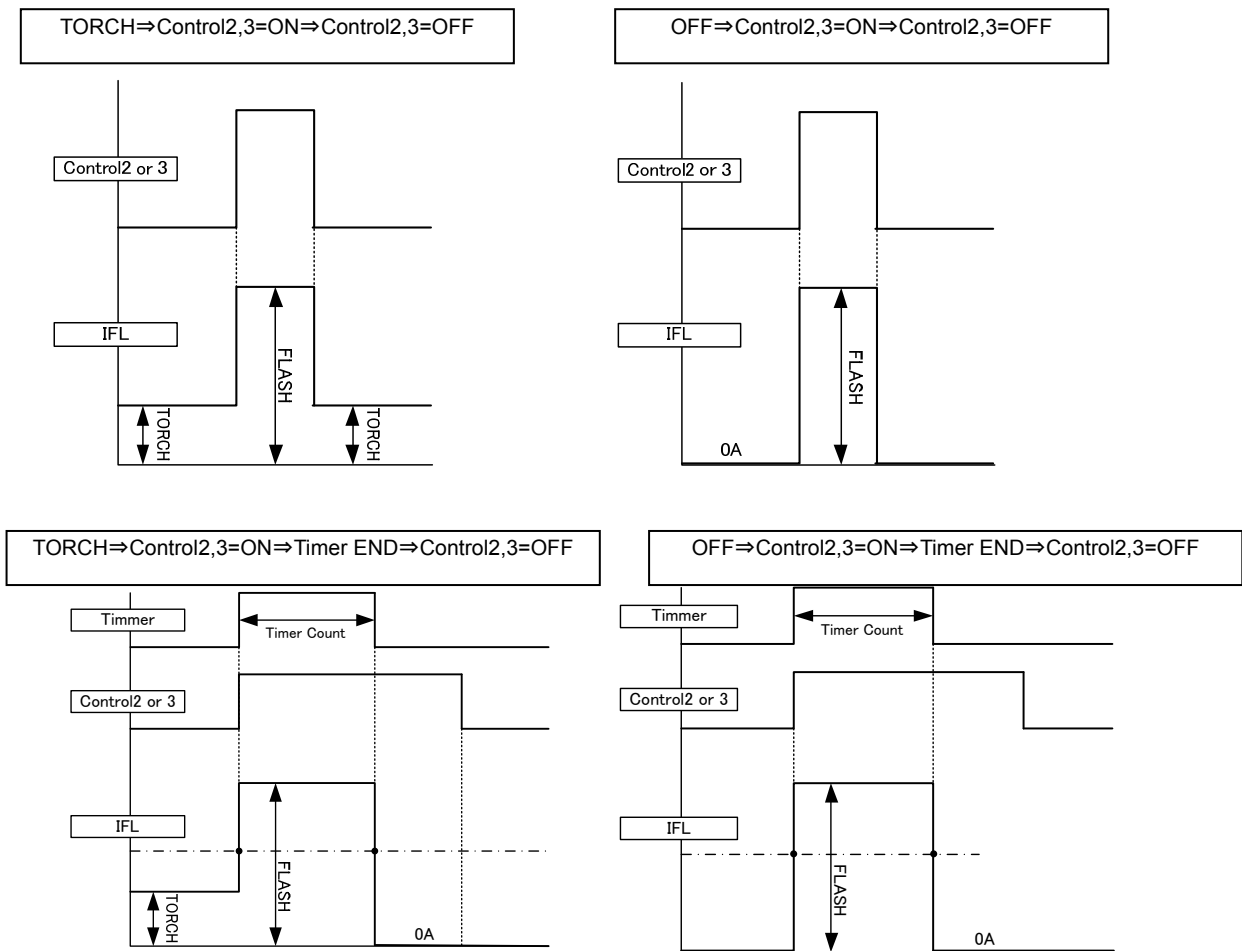

Figure 19. LED Current Operation by Control2, 3

○ Forced Torch (FINH)

Setting address=1 and data=4 through control1, LED current will enter Torch mode correspondingly. This mode has the highest priority, and makes the light switch on in TORCH mode even in lighting state at all times.

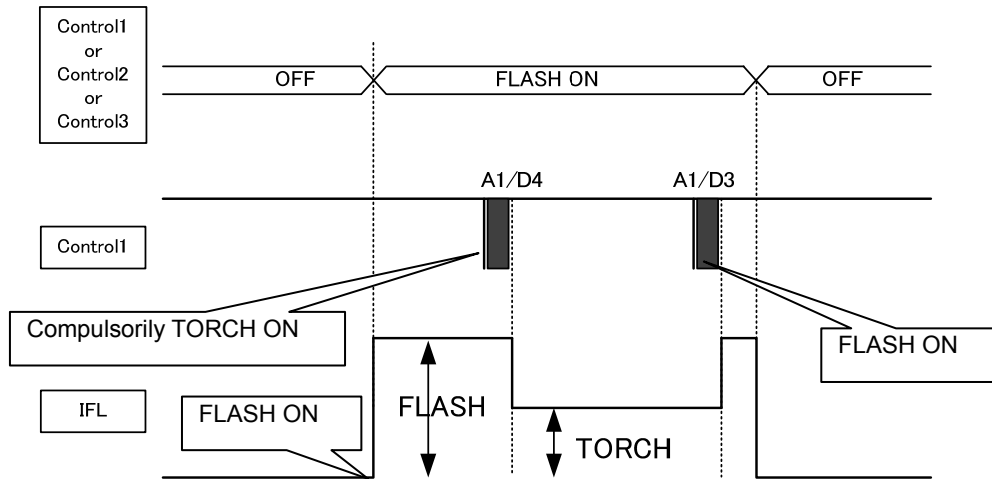

Figure 20. LED current operation by FINH (A1/D4)

Therefore, even if the mode is set Flash mode by Control2 or 3, the output remains at Torch mode.

Startup in compulsive Flash operation by Control2 or 3=H and Control1=Low state, Control1 cannot receive signal while Control2 or 3=H. Therefore, when FINH setting is assumed during the compulsive flash operation by control2 or 3, first of all, please input anything signal into control1 (for keeping control1=H state). And control1 becomes possible receiving the FINH signal also during the compulsive FLASH operation by setting control2 or 3=High state.

○ Torch mode

To go to Torch mode, Control1 sets data=2 in address 1.

TORCH current can be set by 0% to 100% with 16 steps.

In addition, sending Address=1 and data=4 through Control1, IC goes to Torch mode forcibly (Please refer to [forced TORCH])

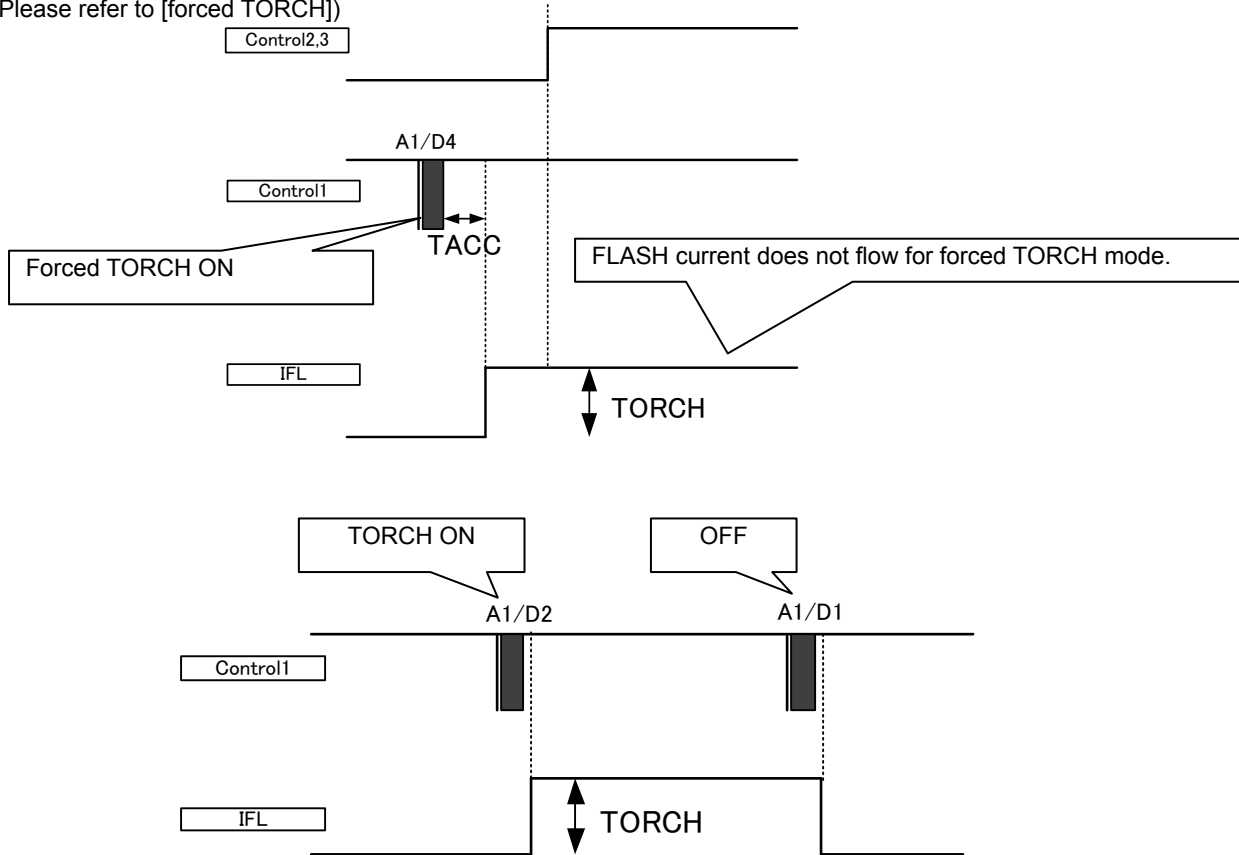

Figure 21. LED Current Operation (Torch Mode)

7. Protect function

FAILURE MODE	DETECTION MODE	LED Current	DCDC Action	After Release Failure	Register State	Condition for releasing latch
LED Open	OVP Detect	Stop	Stop	Auto return	Keep	-
LED Short	LED Short Detect	Stop	Stop	Latch	Keep	Reset by Control1,2,3 or UVLO
RSET Short	ISET Short Detect	Stop	Stop	Auto return	Keep	-
COUT Short	Output Short Detect	Stop	Stop	Auto return	Keep	-
High Temperature	TSD Detect	Stop	Stop	Latch	Reset	Reset by Control1 or UVLO
Low Battery	UVLO Detect	Stop	Stop	Auto return	Reset	-
Low Battery	Low Battery Detect	Stop	Stop	Auto return	Keep	-

○ Over Voltage Protection (OVP) / LED Open Protection (LOP)

Whenever the LED is not connected to FL or OUT terminal, FL terminal voltage becomes Low. Therefore, DC/DC voltage will increase drastically and the VOUT terminal voltage will detect OVP. Then, LED and DCDC driver will stop and output voltage will decrease by discharging. When the output voltage reaches under the OVP hysteresis, DCDC will boost up again and will detect OVP. The over voltage during LED open mode is protected by this operation.

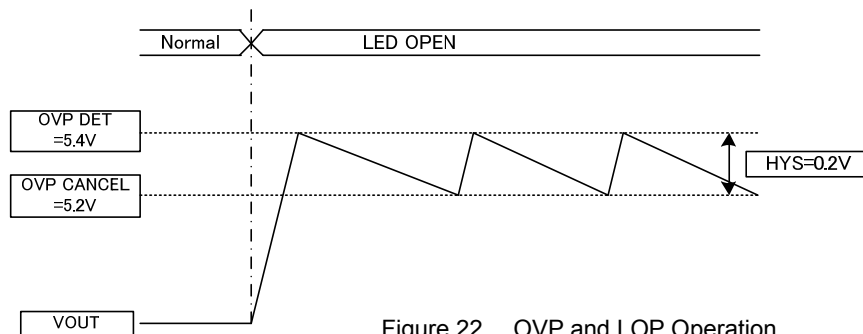

Figure 22. OVP and LOP Operation

○ Output Short Protection

When OUT pin voltage becomes 1.0V or less, the DCDC/LED driver stops and flowing of large current can be prevented in breakdown caused by short mode of output capacitance. This time, constant current of 100mA from OUT pin is sourced. This returns to normal, if short mode is released.

○ OLED Short protection

At start up timing, VOUT is charged until VOUT=VIN state, and LED / DCDC driver starts operating. A test current (2mA typ.) flows from FL terminal before it supplies the LED current. LED is short at this time, If the voltage between FL-OUT pins becomes 1.7V or less, then it becomes latch stop. To release the latch, in the case of lighting by Control1, input Control1=Low or POFF (Address 1 / Data1). In the case of lighting by Control2 or 3, set Control2 or 3 to low

○ Thermal shutdown

If the chip temperature amounts to 155°C or more, thermal shutdown circuit will be enabled and latched. To release the latch, in the case of lighting by Control1, input Control1=Low or POFF (Address 1 / Data1). In the case of lighting by Control2 or 3, set Control2 or 3 to low.

○ Under Voltage Lock Out (UVLO)

If the VIN voltage decreases under 2.2V, UVLO circuit will be enabled. Only when VIN voltage increases over 2.5V will UVLO be cancelled. When the UVLO circuit is enabled, all the systems and register setup will also be reset.

○ Low Battery UVLO

Low Battery UVLO can set the threshold from 2.8V to 3.8V using the register. In addition, It can be set to no detect mode. The registers are not reset when the protection circuit is triggered. When IN voltage increases to more than the hysteresis level (0.1V typ.), it will re-start.

Application Circuit

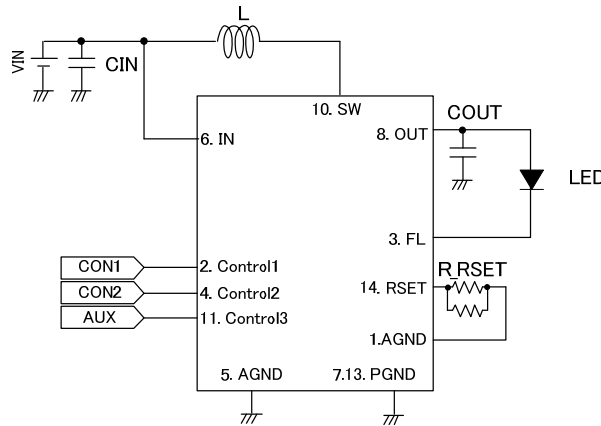

Figure 23. Application Circuit

※It is recommended to connect the R_RSET resistance, which sets up the LED current between pin14:RSET and pin1:AGND. Moreover, do not connect pin1 to GND of the DUT board. (Pin1 AGND and pin5 AGND is shorted inside the IC)

Selection of Components Externally Connected

Parts Name	Symbol	Value			Unit	Product Number
		MIN	TYP	MAX		
Input Capacitor	CIN	1.0	2.2	-	μF	MURATA : GRM188B31A225KE33
Inductor	L	-	1.0	-	μH	TDK : VLF403210MT-1R0N
Output Capacitor	COUT	1.8	4.7	-	μF	MURATA : GRM188B30J475KE18
LED Current Setting Resistor	R_RSET	60	-	120	kΩ	(60kΩ) ROHM : MCR006YZPD1203 //2

○Inductor

As an important characteristic of an inductor, it increases the allowable current and serial resistive components. The step up ratio is high. Thus, when the output LED current is high, the current which flows into the inductor becomes very high. Therefore, it is necessary to select an inductor with high maximum allowable current. Moreover, efficiency is affected by the series resistance components. Therefore, it is recommended that there is a margin to the maximum allowable current. Selecting the inductor with a small series resistance value is also suggested.

• Inductor Current Calculation

The current which flows into the inductor is determined by the following conditions:

- Output voltage=VOUT [V]
- LED current=ILED [A]
- Input voltage=VIN [V]
- PMOS ONR=PONR[Ω]
- Feed Back voltage=VFB[V]
- Inductor series resistance value=RL[Ω]
- efficiency=η [%]

The average current needed for the application is called for using the formula.

$$I_{IN}[A] = \frac{(V_{OUT}[V] - PONR \times I_{LED} - V_{FB} - R_L[\Omega] \times I_{LED}) \times I_{LED}[A]}{V_{IN}[V] \times \eta[\%]}$$

In the driver operation with DCDC switching frequency=fsw[Hz], The ripple current ΔIL[A] which occurs in inductor L [H] is described by the formula:

$$\Delta IL = \frac{(V_{OUT}[V] - V_{IN}[V]) \times V_{IN}[V]}{L[H] \times V_{OUT}[V] \times f_{sw}[Hz]} \quad [A]$$

Therefore, the peak current of the inductor becomes,

$$I_{peak} = I_{IN}[A] + \frac{\Delta IL[A]}{2} \quad [A] \dots (1)$$

(1) Formula of the inductor current at DCDC operation. The inductor current DCDC stops, becomes the current running through the LED.

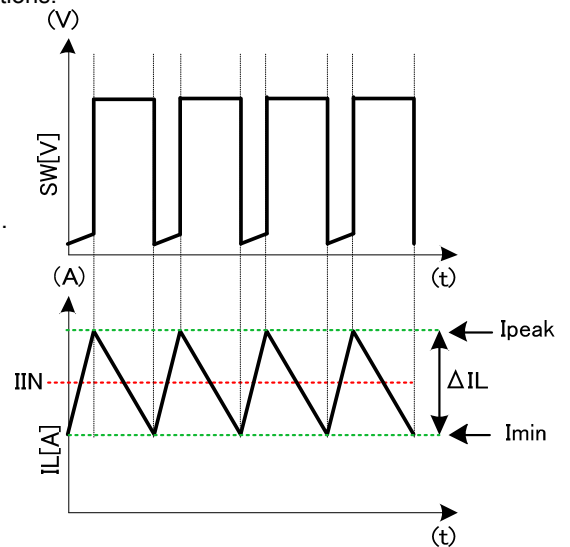

Figure 24. Inductor current

- Example computation

Output voltage=4V

LED current=1.0 [A]

Input voltage=3.6 [V]

Efficiency=85 [%]

L=1.0[μ H]

Freq=2[MHz]

PMOS ONR=0.15[Ω]

Feed Back voltage=0.23[V]

Inductor series resistor value=0.05[Ω]

The peak current of the inductor in this condition is computed.

$$I_{IN}[A] = \frac{(4[V] - 0.15[\Omega] \times 1.0[A] - 0.23[V] - 0.05[\Omega] \times 1.0[A]) \times 1.0[A]}{3.6[V] \times 85[\%]} = 1.17[A]$$

$$\Delta I_L = \frac{(4.0[V] - 3.6[V]) \times 3.6[V]}{1.0E^{-6}[H] \times 4.0[V] \times 2E^6[Hz]} = 0.18 [A]$$

$$I_{peak} = 1.17[A] + \frac{0.18[A]}{2} = 1.26 [A]$$

○Input /Output Capacitor

High current is charged and discharged to the input / output capacitor at that time of DCDC switching operation. Therefore, if a capacitor of high ESR is used, ripple will occur and efficiency will get worse. It is recommended to use a ceramic capacitor of small ESR.

○Resistor for LED current

LED current is set by the resistor which is connecting RSET and AGND terminal. Since the temperature characteristics and variation of the resistance influences the LED current directly, It is recommend to use a resistance of low temperature characteristics and variation.

Power Dissipation

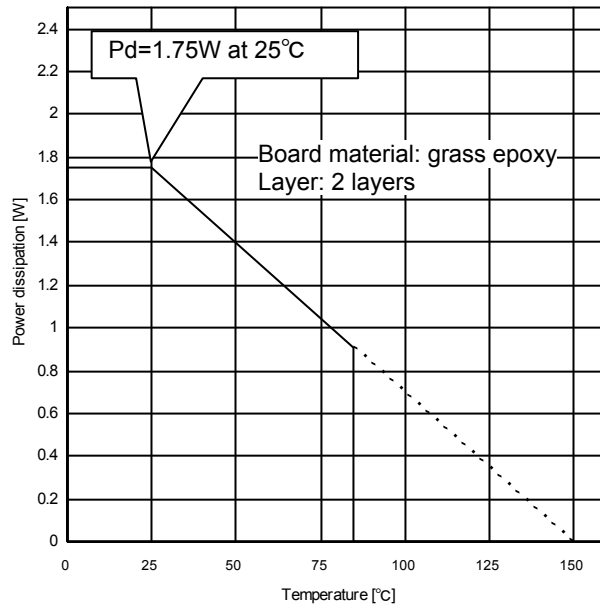
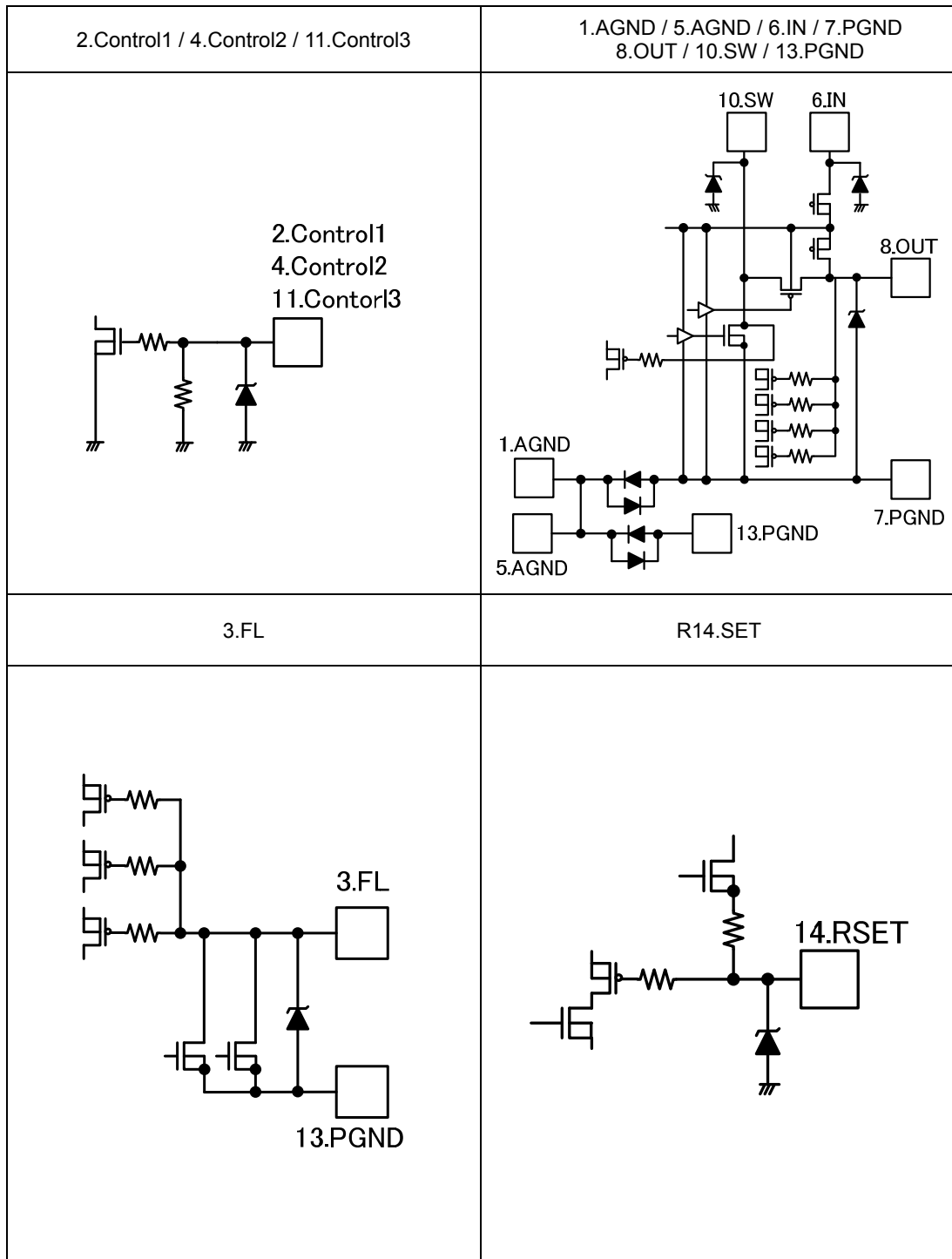

Figure 25. Power Dissipation [W] vs. Temperature [°C]

I/O Equivalent Circuits



Notice for PCB layout

Since high current flows into the DUT during FLASH lighting, the ground voltage is changed by the very small impedance of the PCB pattern. Moreover, PCB layout is very important because it changes with PCB patterns. The voltage drop across the pattern also affects the efficiency and ripple.

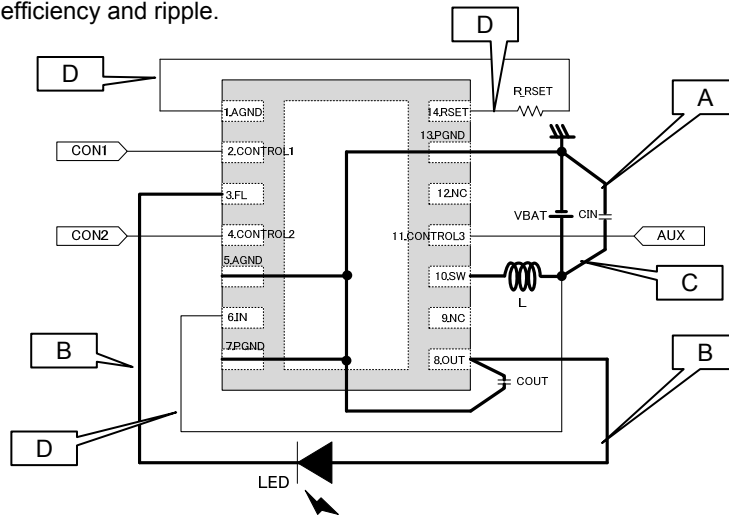

Figure 26. Application Circuit for PCB

Power GND wire

“A” line is Power GND wire. High current flows through this wire from 7Pin-PGND and 13Pin-PGND. Therefore, by wiring it shortly and as thickly as possible, the potential difference across the wiring will not affect the operation. Please short the patterns of the following pin directly 5Pin: AGND, 7Pin: PGND, 13Pin: PGND. Addition of a heat sink to this GND pattern is also recommended. The heat dissipation of IC is high thus wiring area has to be large.

LED wire

The LED current flows through the “B” line. Since a high current (LED maximum current is 1.5A) flows into this line, it is necessary to make it as thick as possible. The impedance across the line will cause a decrease in efficiency.

DCDC wire

“C” line is a course which the current passes through the inductor. Since the high current of LED current and DCDC step-up current flows into this line, it is necessary to make it as thick as possible. The impedance across the line will cause a decrease in efficiency.

Analog wire

“D” line is an analog line. Since high current does not flow into this wiring, it is acceptable to use thin wiring. However, since RSET terminal is very weak to a switching noise, Precautions must be taken to avoid crosstalk with SW terminal. As a recommendation, R_RSET has to be placed immediately near the terminal. By shortening distance between resistance R_RSET and RSET terminal (about under 5mm), crosstalk can be avoided.

Regarding capacitor

Output capacitor has to be placed near the OUT terminal and connect GND to Power GND.
Input capacitor has to be place near the inductor and connect GND to Power GND.

If the wiring impedance against the capacitance serially attaches, it becomes ripple factors of VIN voltage and OUT voltage. It also causes a decrease in efficiency.

The example of a layout of ROHM evaluation board (2 layers) is shown as reference below.

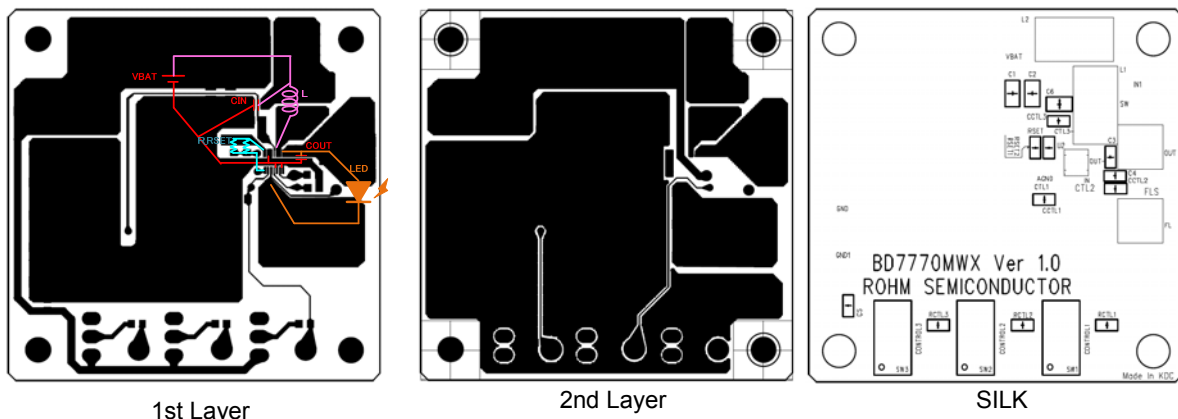

Figure 27. Example of PCB

Operational Notes

1. Reverse Connection of Power Supply

Connecting the power supply in reverse polarity can damage the IC. Take precautions against reverse polarity when connecting the power supply, such as mounting an external diode between the power supply and the IC's power supply pins.

2. Power Supply Lines

Design the PCB layout pattern to provide low impedance supply lines. Separate the ground and supply lines of the digital and analog blocks to prevent noise in the ground and supply lines of the digital block from affecting the analog block. Furthermore, connect a capacitor to ground at all power supply pins. Consider the effect of temperature and aging on the capacitance value when using electrolytic capacitors.

3. Ground Voltage

Ensure that no pins are at a voltage below that of the ground pin at any time, even during transient condition.

4. Ground Wiring Pattern

When using both small-signal and large-current ground traces, the two ground traces should be routed separately but connected to a single ground at the reference point of the application board to avoid fluctuations in the small-signal ground caused by large currents. Also ensure that the ground traces of external components do not cause variations on the ground voltage. The ground lines must be as short and thick as possible to reduce line impedance.

5. Thermal Consideration

Should by any chance the power dissipation rating be exceeded the rise in temperature of the chip may result in deterioration of the properties of the chip. The absolute maximum rating of the Pd stated in this specification is when the IC is mounted on a 70mm x 70mm x 1.6mm glass epoxy board. In case of exceeding this absolute maximum rating, increase the board size and copper area to prevent exceeding the Pd rating.

6. Recommended Operating Conditions

These conditions represent a range within which the expected characteristics of the IC can be approximately obtained. The electrical characteristics are guaranteed under the conditions of each parameter.

7. Inrush Current

When power is first supplied to the IC, it is possible that the internal logic may be unstable and inrush current may flow instantaneously due to the internal powering sequence and delays, especially if the IC has more than one power supply. Therefore, give special consideration to power coupling capacitance, power wiring, width of ground wiring, and routing of connections.

8. Operation Under Strong Electromagnetic Field

Operating the IC in the presence of a strong electromagnetic field may cause the IC to malfunction.

9. Testing on Application Boards

When testing the IC on an application board, connecting a capacitor directly to a low-impedance output pin may subject the IC to stress. Always discharge capacitors completely after each process or step. The IC's power supply should always be turned off completely before connecting or removing it from the test setup during the inspection process. To prevent damage from static discharge, ground the IC during assembly and use similar precautions during transport and storage.

10. Inter-pin Short and Mounting Errors

Ensure that the direction and position are correct when mounting the IC on the PCB. Incorrect mounting may result in damaging the IC. Avoid nearby pins being shorted to each other especially to ground, power supply and output pin. Inter-pin shorts could be due to many reasons such as metal particles, water droplets (in very humid environment) and unintentional solder bridge deposited in between pins during assembly to name a few.

Operational Notes – continued

11. Unused Input Pins

Input pins of an IC are often connected to the gate of a MOS transistor. The gate has extremely high impedance and extremely low capacitance. If left unconnected, the electric field from the outside can easily charge it. The small charge acquired in this way is enough to produce a significant effect on the conduction through the transistor and cause unexpected operation of the IC. So unless otherwise specified, unused input pins should be connected to the power supply or ground line.

12. Regarding the Input Pin of the IC

This monolithic IC contains P+ isolation and P substrate layers between adjacent elements in order to keep them isolated. P-N junctions are formed at the intersection of the P layers with the N layers of other elements, creating a parasitic diode or transistor. For example (refer to figure below):

When $GND > Pin A$ and $GND > Pin B$, the P-N junction operates as a parasitic diode.
When $GND > Pin B$, the P-N junction operates as a parasitic transistor.

Parasitic diodes inevitably occur in the structure of the IC. The operation of parasitic diodes can result in mutual interference among circuits, operational faults, or physical damage. Therefore, conditions that cause these diodes to operate, such as applying a voltage lower than the GND voltage to an input pin (and thus to the P substrate) should be avoided.

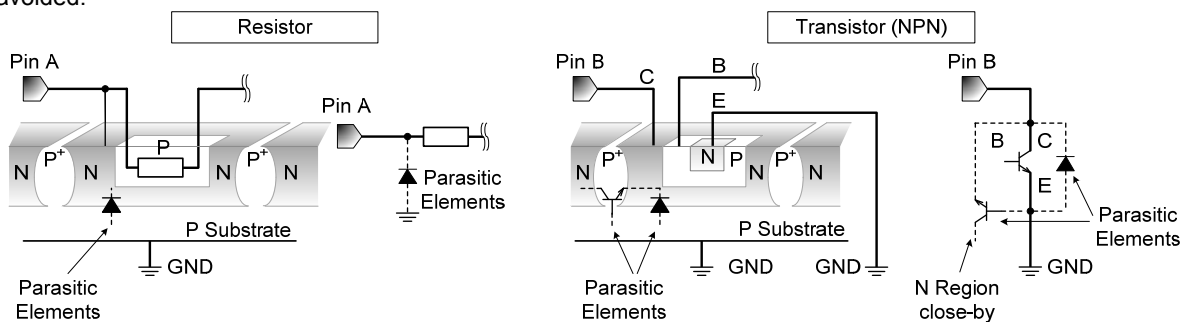

Figure 28. Example of monolithic IC structure

13. Ceramic Capacitor

When using a ceramic capacitor, determine the dielectric constant considering the change of capacitance with temperature and the decrease in nominal capacitance due to DC bias and others.

14. Area of Safe Operation (ASO)

Operate the IC such that the output voltage, output current, and power dissipation are all within the Area of Safe Operation (ASO).

15. Thermal Shutdown Circuit(TSD)

This IC has a built-in thermal shutdown circuit that prevents heat damage to the IC. Normal operation should always be within the IC's power dissipation rating. If however the rating is exceeded for a continued period, the junction temperature (T_j) will rise which will activate the TSD circuit that will turn OFF all output pins and latch.

Note that the TSD circuit operates in a situation that exceeds the absolute maximum ratings and therefore, under no circumstances, should the TSD circuit be used in a set design or for any purpose other than protecting the IC from heat damage.

16. Over Current Protection Circuit (OCP)

This IC incorporates an integrated overcurrent protection circuit that is activated when the load is shorted. This protection circuit is effective in preventing damage due to sudden and unexpected incidents. However, the IC should not be used in applications characterized by continuous operation or transitioning of the protection circuit.

●Ordering Information

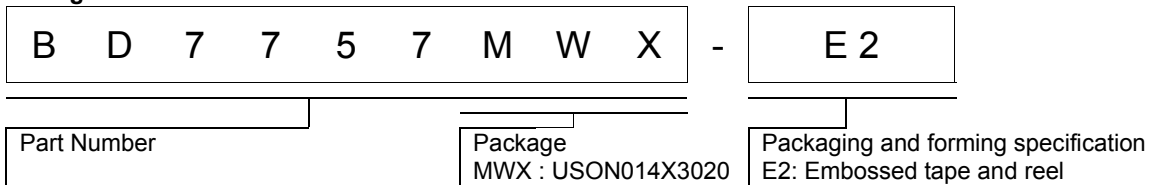

●Physical Dimension Tape and Reel Information

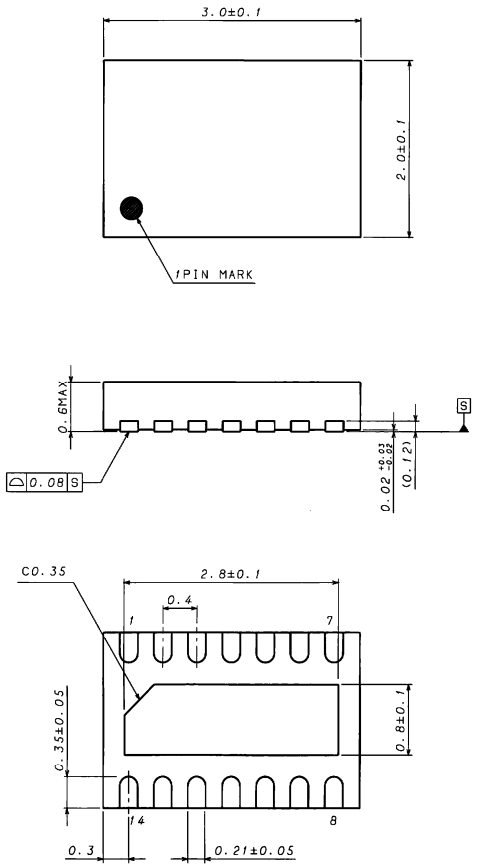

< Tape and Reel Information >

Tape	Embossed carrier tape
Quantity	4000pcs
Direction of feed	E2 The direction is the pin 1 of product is at the upper left when you hold reel on the left hand and you pull out the tape on the right hand

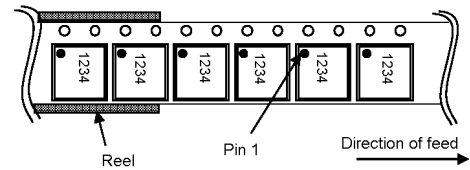

(UNIT : mm)
 PKG : USON014X3020
 Drawing No. USON014X3020x1

●Marking Diagram

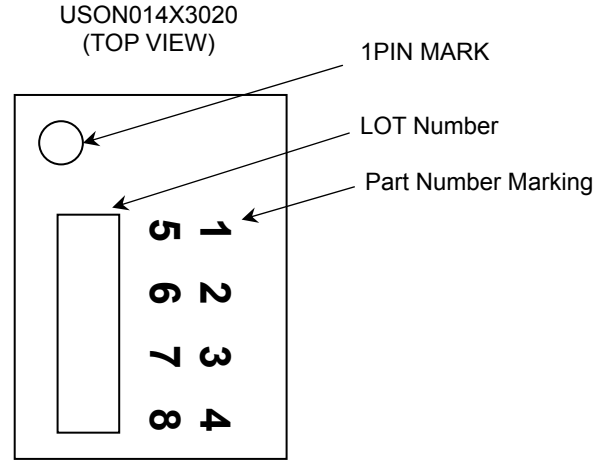

●Revision History

Date	Revision	Changes
OCT.25.2013	002	P14 / Modify Indication of FINH data A1D5->A1D4
NOV.07.2013	003	P3 P8 P9 P12 /Modify Symbol
NOV.07.2013	003	P3 /Modify MIN Limit of MAX DUTY
NOV.07.2013	003	P10 /Modify the instruction of startup and shut down sequence
NOV.07.2013	003	P11 /Delete the (data=1) comment in table
NOV.07.2013	003	P12 / Delete the (data=1) comment in table
NOV.07.2013	003	P14 /Modify the instruction of Forced Torch (FINH)
NOV.07.2013	003	P15 /Modify the instruction of LED Short Protection, Thermal shutdown, and Battery UVLO
NOV.07.2013	003	P20 /Modify the instruction of Analog wire
NOV.07.2013	003	P21,22 /Modify Operation Notes
DEC.03.2014	004	P2 /Modify the instruction of Control2 and Control3
DEC.03.2014	004	P10 /Modify the instruction of FLASH Action using Control2 or Control3
DEC.03.2014	004	P16 /Modify Selection of Components Externally Connected Limit.
DEC.03.2014	004	P1 /Modify Operating Temperature Range

Notice

Precaution on using ROHM Products

- Our Products are designed and manufactured for application in ordinary electronic equipments (such as AV equipment, OA equipment, telecommunication equipment, home electronic appliances, amusement equipment, etc.). If you intend to use our Products in devices requiring extremely high reliability (such as medical equipment ^(Note 1), transport equipment, traffic equipment, aircraft/spacecraft, nuclear power controllers, fuel controllers, car equipment including car accessories, safety devices, etc.) and whose malfunction or failure may cause loss of human life, bodily injury or serious damage to property ("Specific Applications"), please consult with the ROHM sales representative in advance. Unless otherwise agreed in writing by ROHM in advance, ROHM shall not be in any way responsible or liable for any damages, expenses or losses incurred by you or third parties arising from the use of any ROHM's Products for Specific Applications.

(Note1) Medical Equipment Classification of the Specific Applications

JAPAN	USA	EU	CHINA
CLASS III	CLASS III	CLASS II b	CLASS III
CLASS IV		CLASS III	

- ROHM designs and manufactures its Products subject to strict quality control system. However, semiconductor products can fail or malfunction at a certain rate. Please be sure to implement, at your own responsibilities, adequate safety measures including but not limited to fail-safe design against the physical injury, damage to any property, which a failure or malfunction of our Products may cause. The following are examples of safety measures:
 - Installation of protection circuits or other protective devices to improve system safety
 - Installation of redundant circuits to reduce the impact of single or multiple circuit failure
- Our Products are designed and manufactured for use under standard conditions and not under any special or extraordinary environments or conditions, as exemplified below. Accordingly, ROHM shall not be in any way responsible or liable for any damages, expenses or losses arising from the use of any ROHM's Products under any special or extraordinary environments or conditions. If you intend to use our Products under any special or extraordinary environments or conditions (as exemplified below), your independent verification and confirmation of product performance, reliability, etc. prior to use, must be necessary:
 - Use of our Products in any types of liquid, including water, oils, chemicals, and organic solvents
 - Use of our Products outdoors or in places where the Products are exposed to direct sunlight or dust
 - Use of our Products in places where the Products are exposed to sea wind or corrosive gases, including Cl₂, H₂S, NH₃, SO₂, and NO₂
 - Use of our Products in places where the Products are exposed to static electricity or electromagnetic waves
 - Use of our Products in proximity to heat-producing components, plastic cords, or other flammable items
 - Sealing or coating our Products with resin or other coating materials
 - Use of our Products without cleaning residue of flux (even if you use no-clean type fluxes, cleaning residue of flux is recommended); or Washing our Products by using water or water-soluble cleaning agents for cleaning residue after soldering
 - Use of the Products in places subject to dew condensation
- The Products are not subject to radiation-proof design.
- Please verify and confirm characteristics of the final or mounted products in using the Products.
- In particular, if a transient load (a large amount of load applied in a short period of time, such as pulse. is applied, confirmation of performance characteristics after on-board mounting is strongly recommended. Avoid applying power exceeding normal rated power; exceeding the power rating under steady-state loading condition may negatively affect product performance and reliability.
- De-rate Power Dissipation depending on ambient temperature. When used in sealed area, confirm that it is the use in the range that does not exceed the maximum junction temperature.
- Confirm that operation temperature is within the specified range described in the product specification.
- ROHM shall not be in any way responsible or liable for failure induced under deviant condition from what is defined in this document.

Precaution for Mounting / Circuit board design

- When a highly active halogenous (chlorine, bromine, etc.) flux is used, the residue of flux may negatively affect product performance and reliability.
- In principle, the reflow soldering method must be used on a surface-mount products, the flow soldering method must be used on a through hole mount products. If the flow soldering method is preferred on a surface-mount products, please consult with the ROHM representative in advance.

For details, please refer to ROHM Mounting specification

Precautions Regarding Application Examples and External Circuits

1. If change is made to the constant of an external circuit, please allow a sufficient margin considering variations of the characteristics of the Products and external components, including transient characteristics, as well as static characteristics.
2. You agree that application notes, reference designs, and associated data and information contained in this document are presented only as guidance for Products use. Therefore, in case you use such information, you are solely responsible for it and you must exercise your own independent verification and judgment in the use of such information contained in this document. ROHM shall not be in any way responsible or liable for any damages, expenses or losses incurred by you or third parties arising from the use of such information.

Precaution for Electrostatic

This Product is electrostatic sensitive product, which may be damaged due to electrostatic discharge. Please take proper caution in your manufacturing process and storage so that voltage exceeding the Products maximum rating will not be applied to Products. Please take special care under dry condition (e.g. Grounding of human body / equipment / solder iron, isolation from charged objects, setting of Ionizer, friction prevention and temperature / humidity control).

Precaution for Storage / Transportation

1. Product performance and soldered connections may deteriorate if the Products are stored in the places where:
 - [a] the Products are exposed to sea winds or corrosive gases, including Cl₂, H₂S, NH₃, SO₂, and NO₂
 - [b] the temperature or humidity exceeds those recommended by ROHM
 - [c] the Products are exposed to direct sunshine or condensation
 - [d] the Products are exposed to high Electrostatic
2. Even under ROHM recommended storage condition, solderability of products out of recommended storage time period may be degraded. It is strongly recommended to confirm solderability before using Products of which storage time is exceeding the recommended storage time period.
3. Store / transport cartons in the correct direction, which is indicated on a carton with a symbol. Otherwise bent leads may occur due to excessive stress applied when dropping of a carton.
4. Use Products within the specified time after opening a humidity barrier bag. Baking is required before using Products of which storage time is exceeding the recommended storage time period.

Precaution for Product Label

A two-dimensional barcode printed on ROHM Products label is for ROHM's internal use only.

Precaution for Disposition

When disposing Products please dispose them properly using an authorized industry waste company.

Precaution for Foreign Exchange and Foreign Trade act

Since concerned goods might be fallen under listed items of export control prescribed by Foreign exchange and Foreign trade act, please consult with ROHM in case of export.

Precaution Regarding Intellectual Property Rights

1. All information and data including but not limited to application example contained in this document is for reference only. ROHM does not warrant that foregoing information or data will not infringe any intellectual property rights or any other rights of any third party regarding such information or data.
2. ROHM shall not have any obligations where the claims, actions or demands arising from the combination of the Products with other articles such as components, circuits, systems or external equipment (including software).
3. No license, expressly or implied, is granted hereby under any intellectual property rights or other rights of ROHM or any third parties with respect to the Products or the information contained in this document. Provided, however, that ROHM will not assert its intellectual property rights or other rights against you or your customers to the extent necessary to manufacture or sell products containing the Products, subject to the terms and conditions herein.

Other Precaution

1. This document may not be reprinted or reproduced, in whole or in part, without prior written consent of ROHM.
2. The Products may not be disassembled, converted, modified, reproduced or otherwise changed without prior written consent of ROHM.
3. In no event shall you use in any way whatsoever the Products and the related technical information contained in the Products or this document for any military purposes, including but not limited to, the development of mass-destruction weapons.
4. The proper names of companies or products described in this document are trademarks or registered trademarks of ROHM, its affiliated companies or third parties.

General Precaution

1. Before you use our Products, you are requested to carefully read this document and fully understand its contents. ROHM shall not be in any way responsible or liable for failure, malfunction or accident arising from the use of any ROHM's Products against warning, caution or note contained in this document.
2. All information contained in this document is current as of the issuing date and subject to change without any prior notice. Before purchasing or using ROHM's Products, please confirm the latest information with a ROHM sales representative.
3. The information contained in this document is provided on an "as is" basis and ROHM does not warrant that all information contained in this document is accurate and/or error-free. ROHM shall not be in any way responsible or liable for any damages, expenses or losses incurred by you or third parties resulting from inaccuracy or errors of or concerning such information.

X-ON Electronics

Largest Supplier of Electrical and Electronic Components

Click to view similar products for [LED Lighting Drivers](#) category:

Click to view products by [ROHM](#) manufacturer:

Other Similar products are found below :

[LV5235V-MPB-H](#) [MB39C602PNF-G-JNEFE1](#) [MIC2871YMK-T5](#) [AL1676-10BS7-13](#) [AL1676-20AS7-13](#) [AP5726WUG-7](#) [ICL8201](#)
[IS31BL3228B-UTLS2-TR](#) [IS31BL3506B-TTLS2-TR](#) [AL3157F-7](#) [AP5725FDCG-7](#) [LV52204MTTBG](#) [AP5725WUG-7](#) [STP4CMPQTR](#)
[NCL30086BDR2G](#) [CAT4004BHU2-GT3](#) [LV52207AXA-VH](#) [AP1694AS-13](#) [TLE4242EJ](#) [AS3688](#) [IS31LT3172-GRLS4-TR](#) [TLD2311EL](#)
[KTD2694EDQ-TR](#) [KTZ8864EJAA-TR](#) [IS32LT3174-GRLA3-TR](#) [MP2488DN-LF-Z](#) [NLM0010XTSA1](#) [AL1676-20BS7-13](#)
[ZXLD1370QESTTC](#) [MPQ7220GF-AEC1-P](#) [MPQ7220GR-AEC1-P](#) [MPQ4425BGJ-AEC1-P](#) [MPQ7220GF-AEC1-Z](#) [MPQ7220GR-AEC1-Z](#)
[MPQ4425BGJ-AEC1-Z](#) [IS31FL3737B-QFLS4-TR](#) [IS31FL3239-QFLS4-TR](#) [KTD2058EUAC-TR](#) [KTD2037EWE-TR](#) [DIO5662ST6](#)
[KTD2026BEWE-TR](#) [MAX20052CATC/V+](#) [MAX25606AUP/V+](#) [BD6586MUV-E2](#) [BD9206EFV-E2](#) [LYT4227E](#) [LYT6079C-TL](#)
[MP3394SGF-P](#) [MP4689AGN-P](#) [MPQ4425AGQB-AEC1-Z](#)