

Constant Current LED Drivers

50V 500mA

1ch Source Driver for Automotive

BD83732HFP-M BD83733HFP-M

General Description

BD83732HFP-M and BD83733HFP-M are 50V tolerant LED current drivers. Suitable for Automotive LED applications, it can control light through constant current output with control using PWM.
Having LED open/short detective circuit and LED current de-rating functions integrated, it can deliver high reliability. By utilizing Rohm's patented PBUS function, it is possible to turn OFF all LEDs when a row of LEDs are short/open-circuited if multiple number of the ICs are used. In case the LED connected to the output IOOUT terminal has 2 LEDs in series, BD83732HFP-M has to be used, in case of 3 LEDs in series - BD83733HFP-M (Refer to Page.18 LED Open Detection / Disable LED Open Detection).

Key Specifications

- Input Voltage Range: 4.5V to 42V
- Max Output Current: 500mA (Max)
- Output Current Accuracy: ±5% (Max)
- Operating Temperature Range: -40°C to +125°C

Packages

HRP7

W(Typ) x D(Typ) x H(Max)
9.395mm x 10.540mm x 2.005mm



HRP7

Features

- AEC-Q100 Qualified
- Variable form Constant-Current Source Driver
- PWM Dimming Function
- LED constant current set by external resistor
- LED Current De-rating Function
- LED Open/Short detection
- Disable LED Open Detection at low power supply
- Temperature Protective
- Abnormal Output Detection and Output Functions (PBUS)

Application

- On-board Exterior Lamp
(Rear Lamp, Turn Lamp, DRL/Position Lamp, Fog Lamp, etc.)
- On-board Interior Lamp
(Air Conditioner Lamp, Interior Lamp, Cluster Light, etc.)

Basic Application Circuit

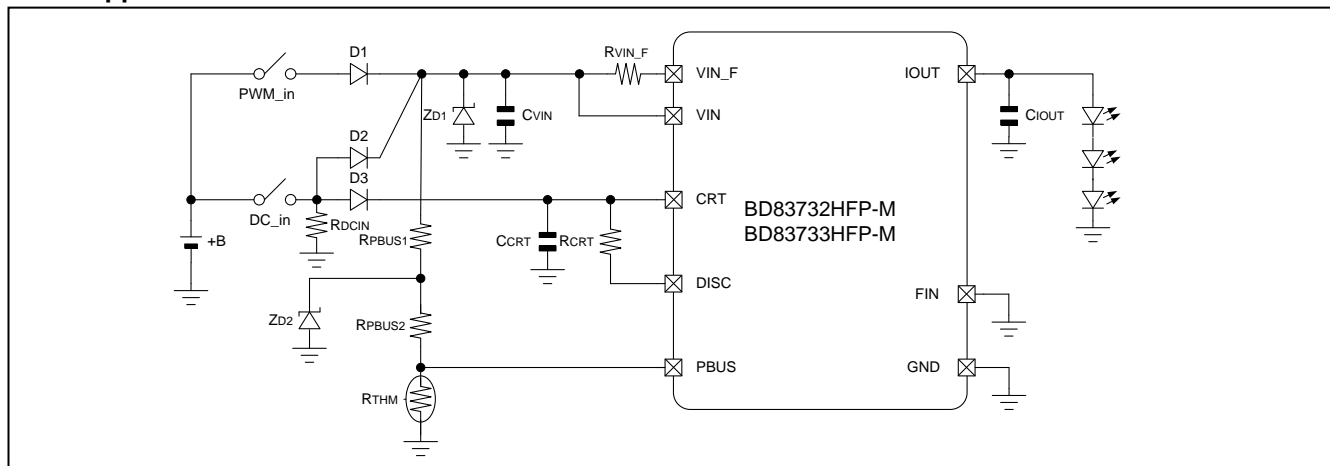

Figure 1. Typical Application Circuit

○Product configuration: Silicon monolithic integrated circuit ○ The product is not designed for radiation resistance.

Pin Configurations

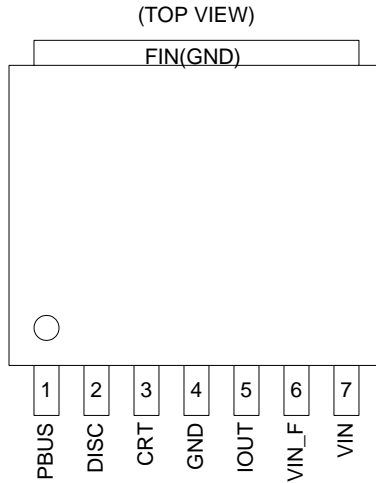

Figure 2. HRP7 Package Pin Configuration

Pin Descriptions

HRP7 Package

Pin No.	Pin Name	Function
1	PBUS	Error detection I/O, LED current de-rating input terminal
2	DISC	Discharge setting pin
3	CRT	Capacitor Resistor Timer setting
4	GND	GND
5	IOUT	Current output
6	VIN_F	Output current detection
7	VIN	Power supply input

If not used DISC should be shorted to GND.

Block Diagram

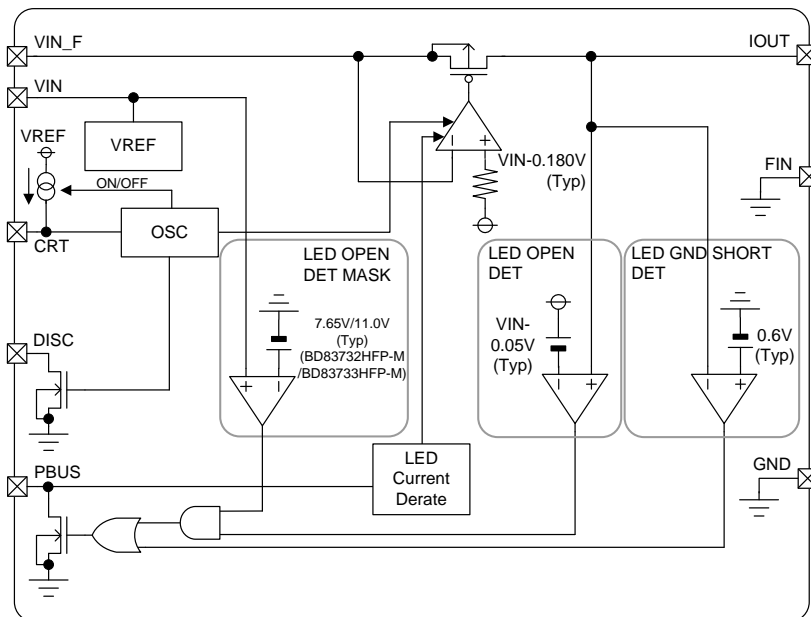

Figure 3. Block Diagram

Absolute Maximum Ratings (Ta=25°C)

Parameter	Symbol	Rating	Unit
Supply Voltage	V _{IN}	-0.3~+50	V
V _{IN} , F, CRT, DISC, IOUT, PBUS Terminal Voltage	V _{VIN_F} , V _{CRT} , V _{DISC} , V _{IOUT} , V _{PBUS}	-0.3~V _{IN}	V
Power Dissipation	P _d	2.29 ^(Note1)	W
Operating Temperature Range	T _{opr}	-40~125	°C
Storage Temperature Range	T _{stg}	-55~150	°C
Junction Temperature	T _{jmax}	150	°C
IOUT Output Maximum Current	I _{OUT}	500	mA

(Note1) HRP7
De-rate by 18.4mW/°C when operating above Ta=25°C
Please refer to page 21 below.

Caution: Operating the IC over the absolute maximum ratings may damage the IC. The damage can either be a short circuit between pins or an open circuit between pins and the internal circuitry. Therefore, it is important to consider circuit protection measures, such as adding a fuse, in case the IC is operated over the absolute maximum ratings.

Recommended Operating Conditions

Parameter	Symbol	Rating	Unit
Supply Voltage ^(Note1)	V _{IN}	4.5~42.0	V
Operating Temperature Range	T _{opr}	-40~125	°C
CRTIMER Frequency Range	F _{PWM}	100~5000	Hz
PWM Minimum Pulse Width	T _{MIN}	10	μs

(Note1) P_d, A_{SO} should not be exceeded

Operating Conditions

Parameter	Symbol	Min	Max	Unit
Current Setting Resistor	R _{VIN_F}	0.36	3.6	Ω
Capacitor connecting V _{IN} terminal	C _{vin}	1.0	-	μF
Capacitor connecting IOUT terminal	C _{IOUT}	0.1	0.66	μF
Capacitor connecting CRT terminal	C _{CRT}	0.01	1.0	μF
DC_IN pull-down resistor	R _{DCIN}	-	50	kΩ

Electrical Characteristics (Unless otherwise specified Ta=-40~125°C, VIN= 13V, RVIN_F=0.47Ω, RPBUS=10kΩ)

Parameter	Symbol	Min	Typ	Max	UNIT	Condition
Circuit Current	IVIN	-	2.1	6.0	mA	
IOUT Terminal Output Current Accuracy	IOUT	373	383	393	mA	Ta=25°C
		364	383	402	mA	Ta=-40°C~125°C
VIN – IOUT Drop Voltage	VDR_IOUT	-	0.45	1.0	V	IOUT=383mA
IOUT Terminal OFF Current	IOUT_OFF	-	-	1	μA	VIOUT=2V, VCRT=0.7V Ta=25°C
IOUT Current at GND Short	IOUT_SHORT	-	7	40	μA	VIOUT=0V
Current Sense Voltage	VIN_F_REF	0.171	0.180	0.189	V	VIN_F_REF=VIN-VIN_F
IOUT Voltage at LED Open Detection	VIOUT_OPEN	VIN -0.080	VIN -0.050	VIN -0.020	V	
IOUT Voltage at LED Short Detection	VIOUT_SHORT	0.20	0.67	1.00	V	
CRT Terminal Charge Current	ICRT_SO	29.75	35.00	40.25	μA	VCRT=0.9V
CRT Terminal Voltage	VCRT_CHA	0.990	1.10	1.21	V	
CRT Terminal Discharge Voltage 1	VCRT_DIS1	2.7	3.0	3.3	V	
CRTIMER Discharge Constant	VCRT_CHA / VCRT_DIS1	0.348	0.367	0.386	V/V	
CRT Terminal Discharge Voltage 2	VCRT_DIS2	3.6	4.0	4.4	V	RD1<->RD2 ^(Note1)
CRT Terminal Charge Resistance	RCHA	51.6	54.3	57.0	kΩ	RCHA=(VCRT_DIS1 – VCRT_CHA) / ICRT_SO
DISC Terminal Discharge Resistance 1	RD1	-	50.0	100	Ω	VCRT=3.4V
DISC Terminal Discharge Resistance 2	RD2	2.5	5.0	10	kΩ	VCRT=5V
PBUS Terminal De-rating Input Voltage High	VDH_PBUS	2.3	2.5	2.7	V	ΔVIN_F_REF = 2.0mV ΔVIN_F_REF = VIN_F_REF(@PBUS = 13V) – VIN_F_REF(@PBUS = VDH_PBUS)
PBUS Terminal De-rating Input Voltage Low	VDL_PBUS	0.8	1.0	1.2	V	IOUT<5μA
De-rating Gain	GD	114	120	126	mV/V	ΔIOUT=GD × VPBUS VPBUS=1.5V -> 2.0V
PBUS Terminal Low Voltage	VOL_PBUS	-	-	0.7	V	IPBUS=2mA
PBUS Terminal Input Current	IIN_PBUS	-	38.0	100	μA	VPBUS=13V
Disable Open Detection during low power supply voltage						
BD83732HFP-M	VM_OPEN	7.30	7.65	8.00	V	VIN voltage
BD83733HFP-M	VM_OPEN	10.5	11.0	11.5	V	VIN voltage

● Typical Performance Curves (Reference Data)

(Unless otherwise specified Ta=25°C, VIN=13V, RCRT=3.9kΩ, CCRT=0.033μF, CIOUT=0.1μF)

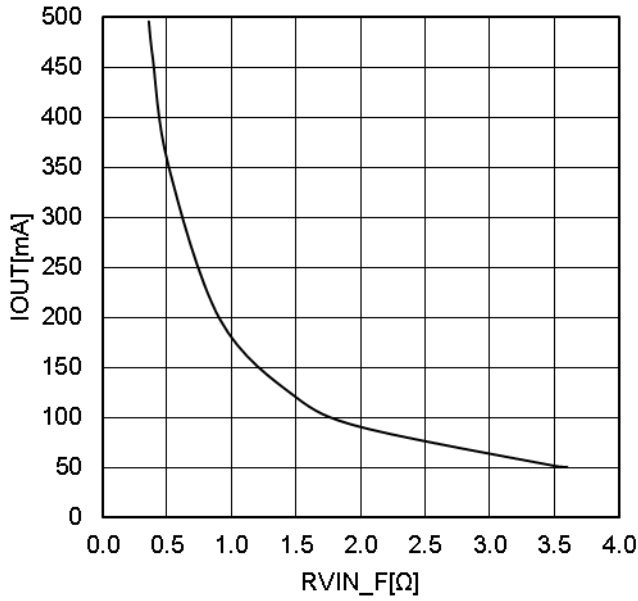

Figure 4. RVIN_F vs IOUT

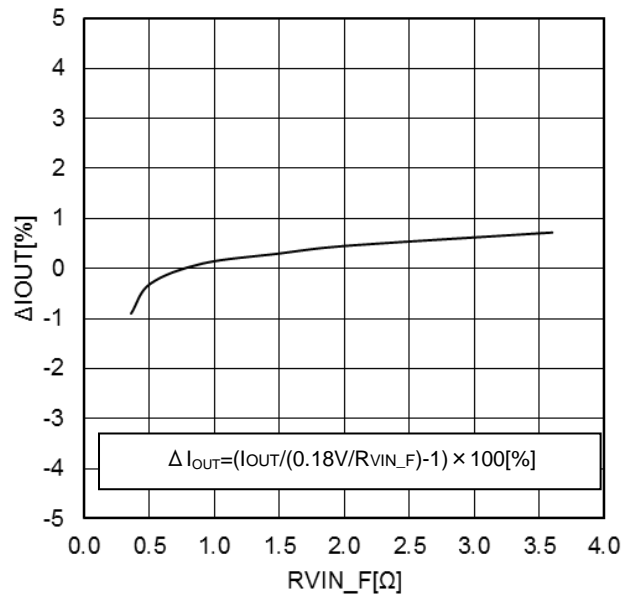

Figure 5. RVIN_F vs ΔIOUT

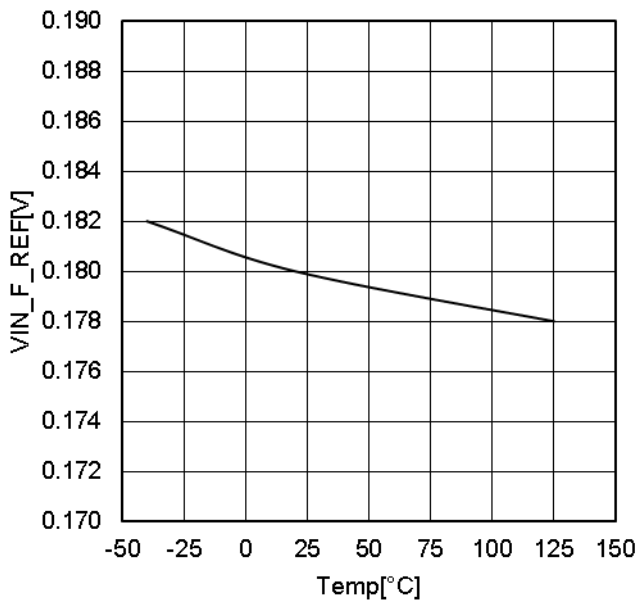

Figure 6. Temperature vs VIN_F_REF

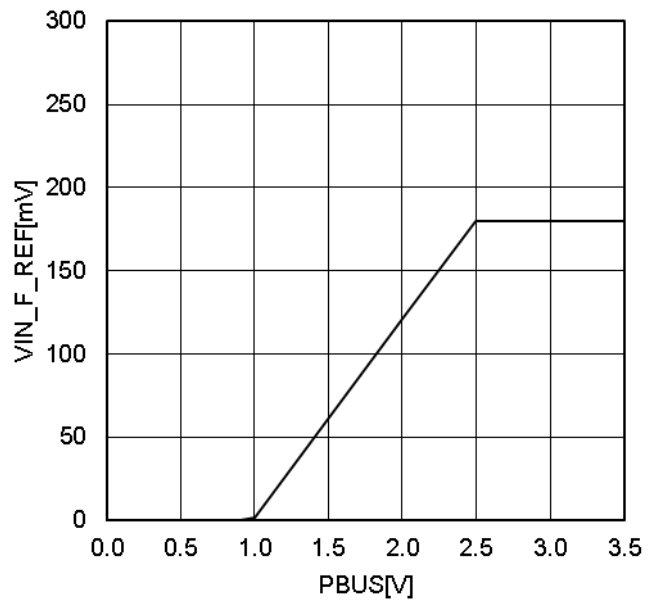

Figure 7. PBUS vs VIN_F_REF

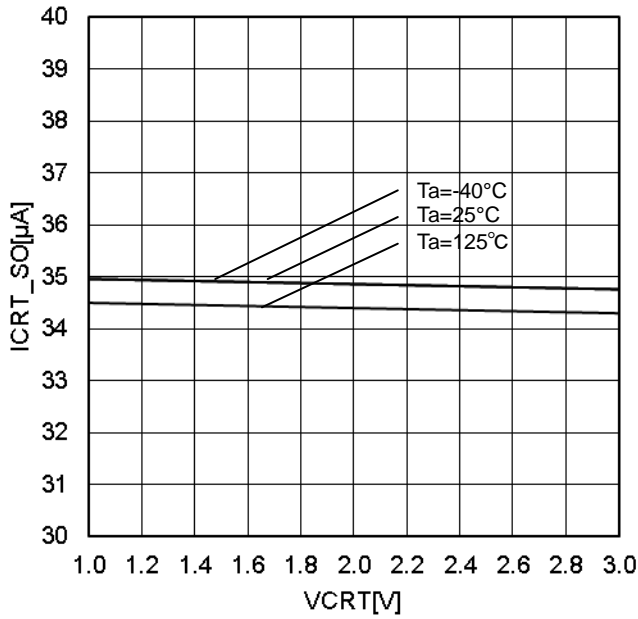

Figure 8. VCRT vs ICRT_SO
(VCRT: CRT Terminal Voltage)

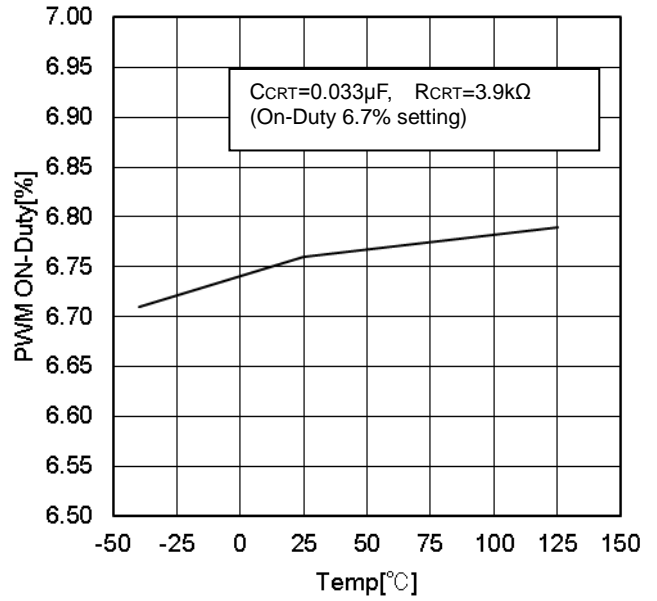

Figure 9. Temperature vs PWM ON Duty

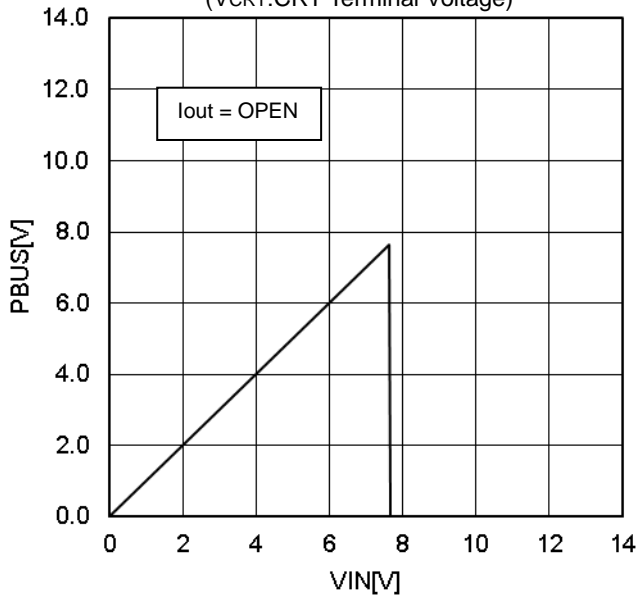

Figure 10. BD83732HFP-M
LED Disable Open Detection voltage

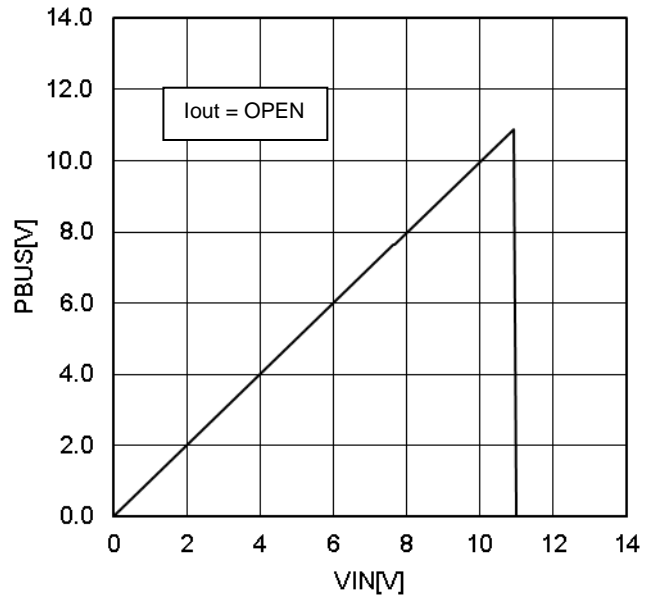

Figure 11. BD83733HFP-M
LED Disable Open Detection voltage

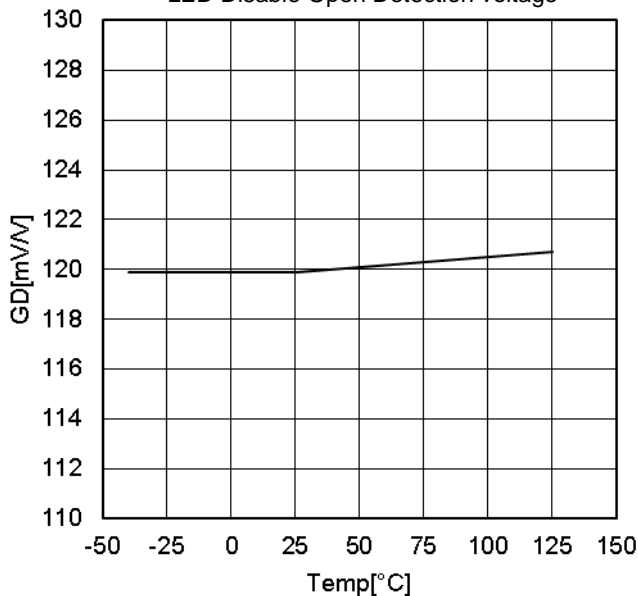

Figure 12. Temperature vs De-rating Gain

Functional Description

(Unless otherwise specified, Ta=25°C, VIN=13V, IOUT=6V and RVIN_F=0.47Ω. Numbers are "Typical" values.)

1. Output Current Setting

LED Current IOUT can be set by value of resistor RVIN_F.

$$I_{OUT} = \frac{(V_{IN} - V_{IN_F})}{R_{VIN_F}} = \frac{V_{IN_F_REF}}{R_{VIN_F}} [A]$$

where:

VIN_F_REF is 0.18V (Typ)

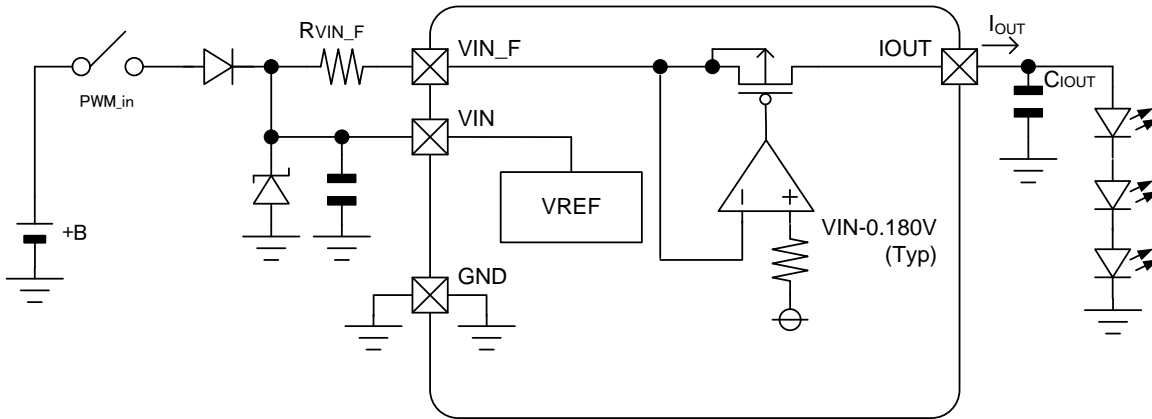

Figure 13. Output Current Setting

2. Table of Operations

The PWM dimming mode switches to linear control depending on CRT terminal voltage.

When VCRT > VCRT_DIS2(Typ ~ 4.0V), Dimming mode turns to Linear Control, and discharge resistance of DISC terminal changes from RD1(Typ ~ 50 Ω) to RD2 (Typ ~ 5k Ω).

When an LED open/short-circuit fault is detected, which depends on IOUT terminal voltage, the output current is turned OFF.

Output current is also turned OFF when PBUS terminal is pulled LOW.

Operation Mode	CRT Terminal	IOUT Terminal Voltage (VIOUT)	Output Current (Iout)	PBUS Terminal
Linear Control	4.0V(Typ)≤VCRT	-	50mA~500mA	Hi-Z
PWM dimming	See Features Functional Description, 3. PWM Dimming Operation	-	See Features Functional Description, 3. PWM Dimming Operation	Hi-Z
LED Current De-rating	-	-	See Features Description, 8. LED Current De-rating Function	PBUS<2.5V
LED Open	-	VIOUT ≥ VIN - .050V(Typ)	1μA(Max)	Low Output
LED Short	-	VIOUT ≤ 0.6V(Typ)	40μA(Max)	Low Output
PBUS Control OFF	-	-	1μA(Max)	Low Input

3. PWM Dimming Operation

PWM Dimming is performed with the following circuit.

The CR timer function is activated if DC_in is OPEN. To perform PWM light control of LED current, a triangular waveform is generated at CRT terminal. The **LED current is turned OFF** while CRT voltage is ramping up, and **LED current is turned ON** while CRT voltage is ramping down.

The ramp up/down time of the CRT voltage, and therefore the dimming cycle and Duty, can be set by values of the external components (**CCRT, RCRT**).

Please connect DISC to GND if it is not used.

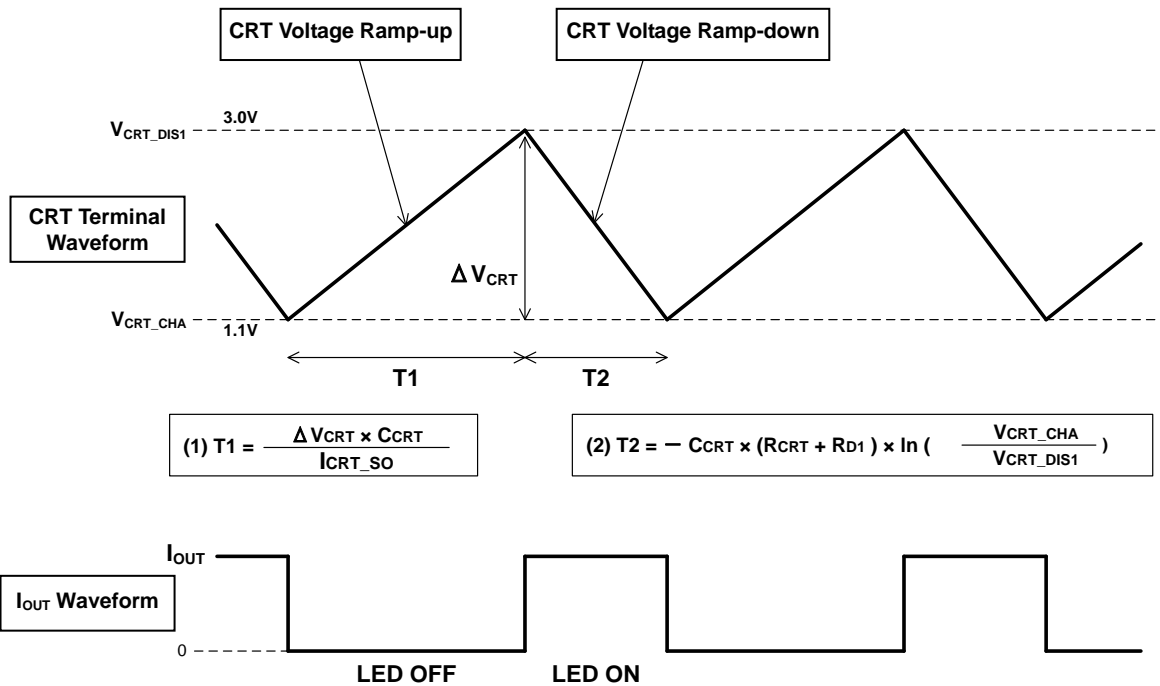
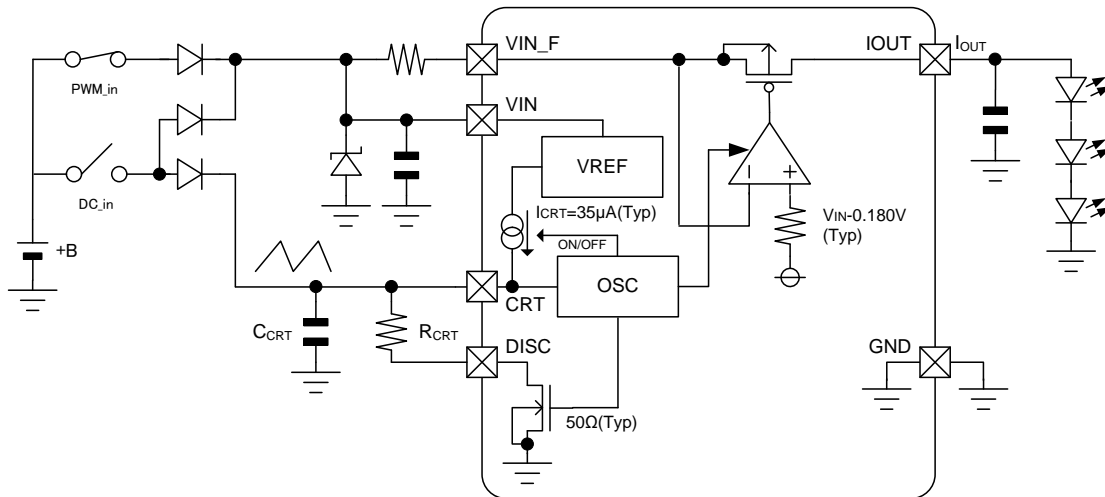

Figure 14. PWM Dimming Operation

- (1) CRT Ramp up Time T1
 CRT ramp up time can be obtained from the following equations:

$$T1 = \frac{\Delta V_{CRT} \times C_{CRT}}{I_{CRT_SO}} = R_{CHA} \times C_{CRT} [s]$$

where:
 ICRT_SO is the CRT Terminal Charge Current 35μA (Typ)
 RCHA is the CRT Terminal Charge Resistance 54.3kΩ(Typ)

- (2) CRT Ramp down Time T2
 CRT ramp down time is defined by the discharge period due to the external capacitor CCRT and resistance (RCRT + RD1). The CRT Terminal Charge Current is OFF at CRT ramp down. Make sure that T2 is set > pulse width 20µs (Min).

$$T2 = -CCRT \times (RCRT + RD1) \times \ln\left(\frac{VCRT_CHA}{VCRT_DIS1}\right) \text{ [s]}$$

where:

- RD1 is the CRT Terminal Discharge Resistance 1 50Ω (Typ)
- VCRT_CHA is the CRT Terminal Discharge ON Voltage 1.1V (Typ)
- VCRT_DIS1 is the CRT Terminal Discharge ON Voltage 3.0V (Typ)

- (3) Dimming Frequency fPWM
 PWM frequency is defined by T1 and T2.

$$f_{PWM} = \frac{1}{T1 + T2} \text{ [Hz]}$$

- (4) ON Duty (DON)
 Like the above, PWM ON duty is defined by T1 and T2.

$$DON = \frac{T2}{T1 + T2}$$

(Example) In case of fPWM = 518Hz and 6.7% Duty (Typ),

From fPWM=518Hz; T1 + T2 = 1 / fPWM = 1 / 518Hz = 1931µs
 From ON Duty = 6.7%; CRT ramp up time T1 is T1 = (T1 + T2) × 0.933 = 1801.6µs
 External capacity CCRT is;
 CCRT = T1 × (ICRT / ΔVCRT) = 1801.6µs × 35µA / 1.9V ≐ **0.033µF**

CRT ramp down time T2 is; T2 = (T1 + T2) × 0.067 = 129µs

External resistance RCRT is;

$$RCRT = -T2 / (CCRT \times \ln(VCRT_CHA / VCRT_DIS1)) - RD1 = -129\text{usec} / (0.033\mu\text{F} \times \ln(1.1 / 3.0)) - 50\Omega \doteq \mathbf{3.9k\Omega}$$

PWM Dimming Operation using external signal

An external microcomputer can directly drive the PWM signal for Dimming CRT terminal. In that case, 'High' level voltage of PWM signal should be > VCRT_DIS2(4.4V(Max)) and 'Low' level voltage of PWM signal < VCRT_CHA(0.99V(Min)).

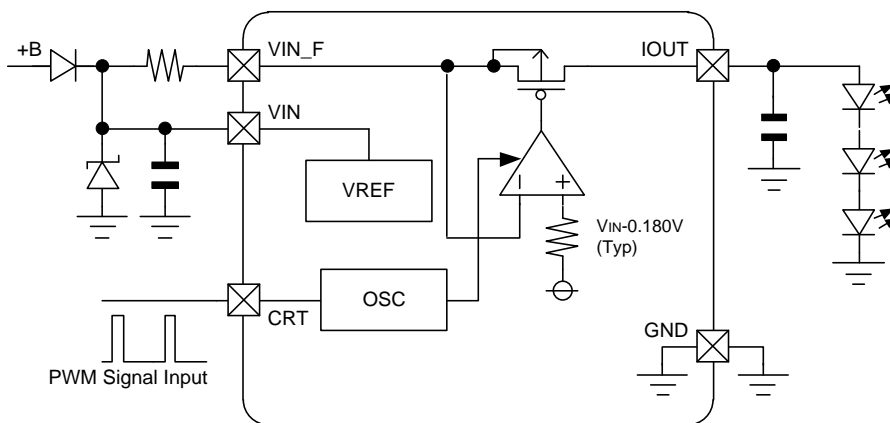

Figure 15. External Input of PWM Signal

About a reverse connection protection diode

In case you apply voltage the CRT over the reverse protection diode (D3) as the figure below (Figure 16), there is a possibility that the CRT rise time and fall time will deviate from the settings due to reverse current of diode (D3) affecting charge and discharge current to capacitance(C3). Reverse current I_r is getting high value with high temperatures, so the diode recommended by ROHM or a diode with reverse current characteristics below max $1\mu A$ needs to be considered. Besides, since reverse current causes also in the recommended diode, **a resistor of about $1k\Omega$ needs to be connected between the A-point and GND**, so that voltage in the A-point doesn't rise.

CRT start-up / fall time Mechanism of deviation from settings

- ① During the PWM dimming operation mode, the A-point on Figure.16 becomes Hi-Z
- ↓
- ② Reverse current I_r of D2 and D3 goes to the A-point
 (Power supply voltage is being input into the cathode of D2, so reverse current of D2 goes to mainly into C1)
⇒ Reverse current I_r of D3 is added to the CRT terminal charge current I_{CRT_so} and discharge current I_{DIS} , so CRT start-up / fall time deviates from the settings.
- ↓
- ③ C1 gets charged, voltage in the A-point rises
- ↓
- ④ Voltage in the A-point exceeds voltage in CRT terminals of each IC
- ↓
- ⑤ V_f occurs in the diodes D3
- ↓
- ⑥ D3 circulate forward current I_f
⇒ Forward current I_f of D3 is added to the CRT terminal charge current I_{CRT_so} and discharge current I_{DIS} , so CRT start-up / fall time deviates from the settings. ↓
- ⑦ Repetition ②-⑥

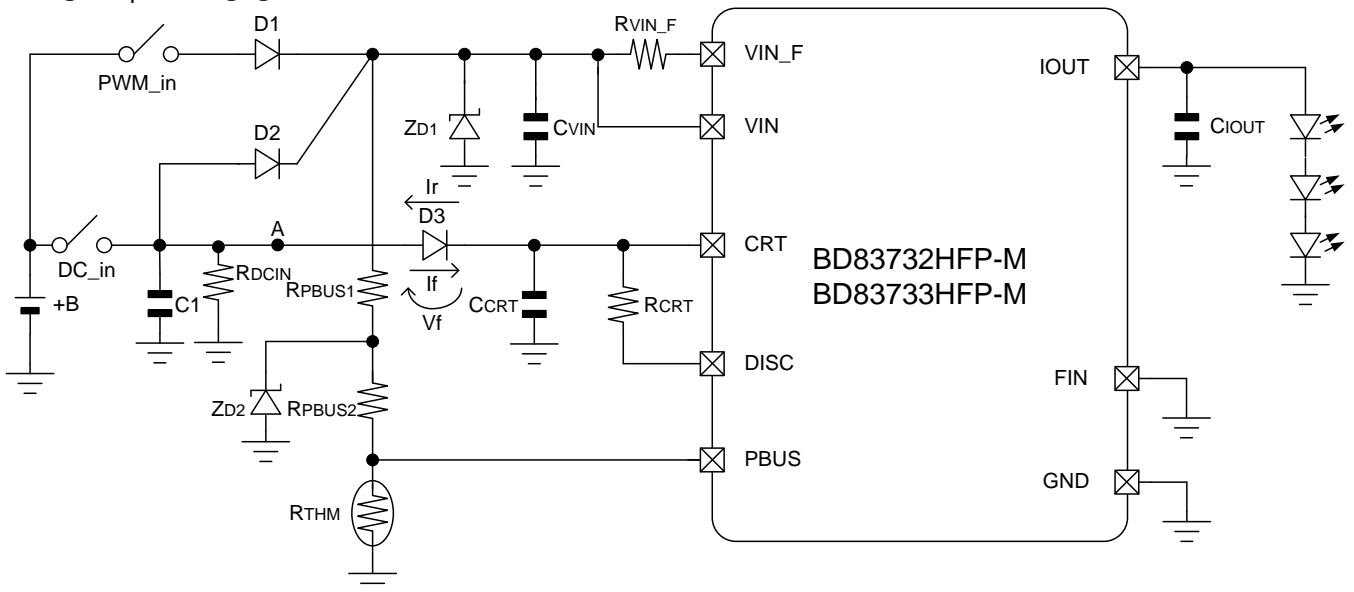

Figure 16. About the mechanism of deviation of CRT start-up / fall time due to the reverse connection prevention diode

4. Setting VIN Range

Number of LED connections N should meet the following conditions:

$$V_{f_led} \times N \leq +B - V_{f_diode} - V_{IN_F_REF} - V_{DR_IOUT}$$

where:

- +B is the Battery Voltage
- V_{f_{diode}} is the Reverse Connection Preventing Diode Vf
- V_{IN_F_REF} is the VIN_F Terminal Voltage (V_{IN} - V_{IN_F})
- V_{DR_{IOUT}} is the IOUT Terminal Drop Voltage
- V_{f_{led}} is the LED Vf (maximum)
- N is the Number of LED Levels

Example : If you want to supply constant current to LED at 9V or higher Battery Voltage (+B) (Supposing that V_{f_{diode}} is 0.5V),

$$V_{f_led} \times N \leq +B - V_{f_diode} - V_{IN_F_REF} - V_{DR_IOUT} = 9V - 0.5V - 0.189V(\text{Max}) - 1.0V(\text{Max}) = 7.311V$$

(Sum of Vf of LED connected to IOUT terminal is set to be 7.311V Max.)

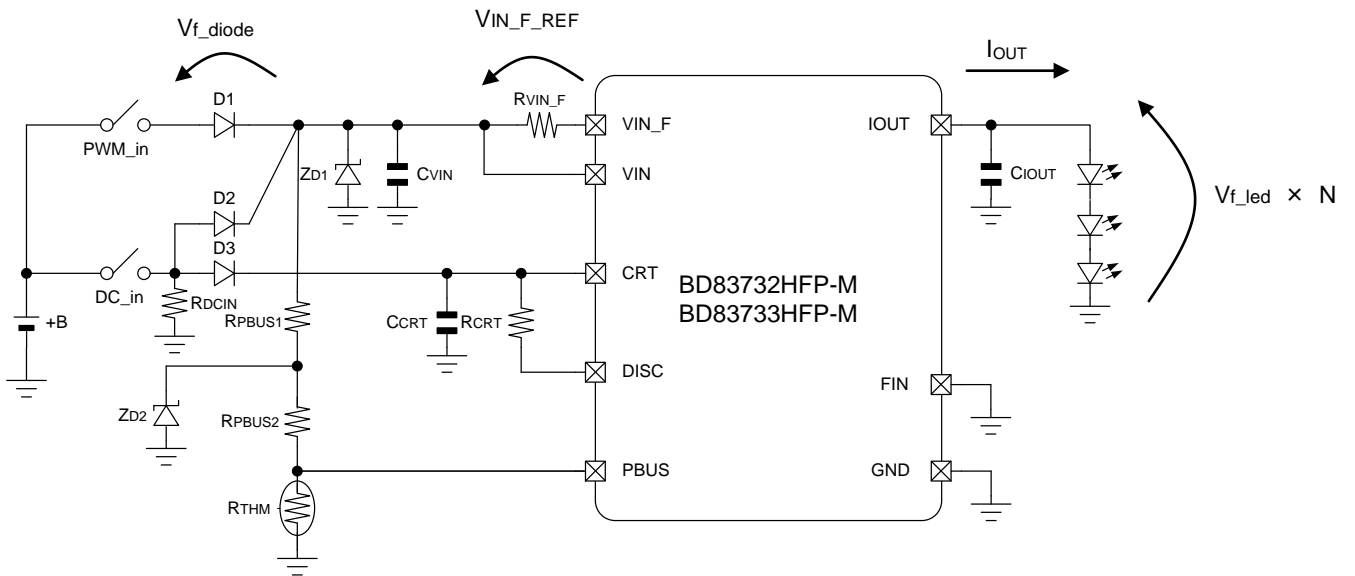

Figure 17. LED Setting Range Schematic

5. Self-protection and PBUS Functionality

This IC includes self-protection from short/open-circuit of LED, and reports abnormal condition at the PBUS terminal.

(1) LED Open Detection Function

When any LED connected to IOOUT terminal is open-circuited, it is detected by overvoltage at IOOUT terminal ($V_{OUT} > V_{IOUT_OPEN}$). Then the output current is turned OFF and PBUS terminal is pulled Low.

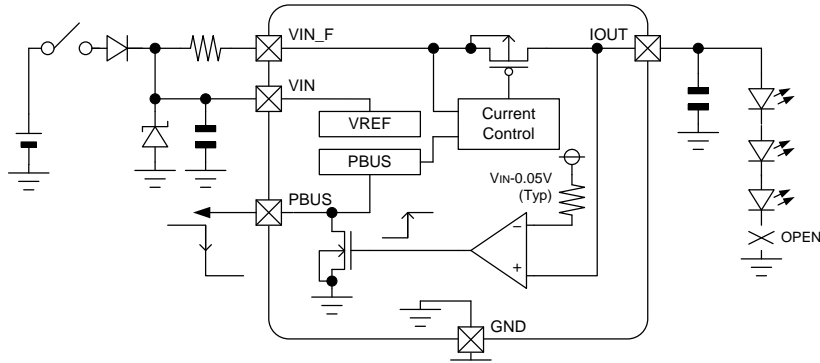

Figure 18. LED Open Detection

(2) LED Short-circuit Detective Function

When the LEDs connected to the IOOUT terminal are short-circuited, it is detected by a low voltage at IOOUT terminal ($V_{OUT} < V_{IOUT_SHORT}$). Then the output current is turned OFF to prevent thermal destruction of IC, and PBUS terminal is pulled to Low.

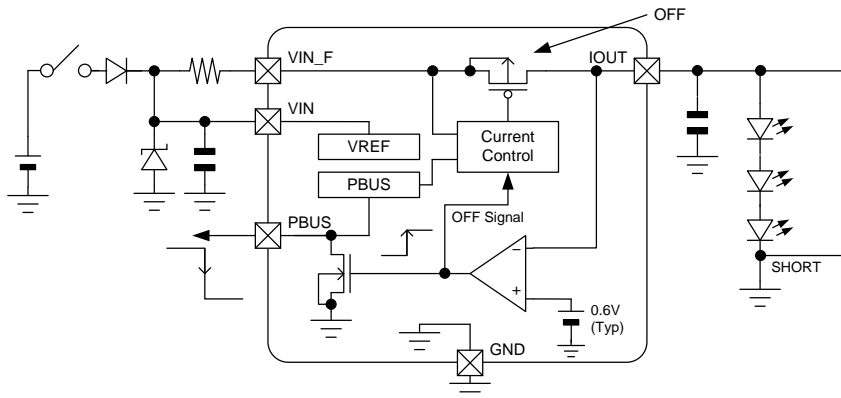

Figure 19. LED Short-circuit Detection

(3) IOOUT Current at GND Short(I_{IOUT_SHORT})

In this case, IOOUT Current at GND Short(I_{IOUT_SHORT}) flows from IOOUT terminal. The value depends upon V_{OUT} .

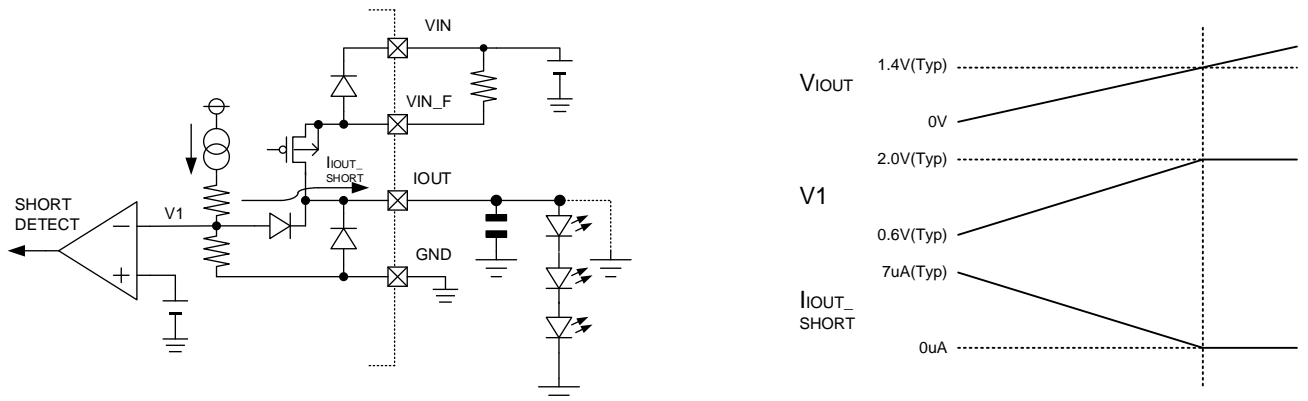

Figure 20. About IOOUT Current at GND Short

(4) Prevention of false LED Short Detection during PWM

When in Linear control mode, LED Open & Short Circuit Detection are active continuously. In PWM Dimming mode, LED Open Detection is active only during the Fall time of VCRT, but LED Short Circuit Detection is active at all time. (Refer to Figure20.) When IOOUT is disabled during PWM, the output will be high impedance ('Hi-Z'). During this time noise ^(Note1) can couple on to this pin and cause false detection of SHORT condition.

To prevent this it is necessary to connect a Capacitor(more than 0.1μF^(Note2)) between IOOUT terminal and GND terminal nearby terminal
(ROHM Recommended Value : CIOUT=0.1μF GCM188R11H104KA42 murata)

(Note1) Conducted noise, Radiated noise, Interference of connector and PCB pattern etc...
 (Note2) If more than 0.1μF, please evaluate the time of VIN on to IOOUT on. (See Page 14 evaluation example)

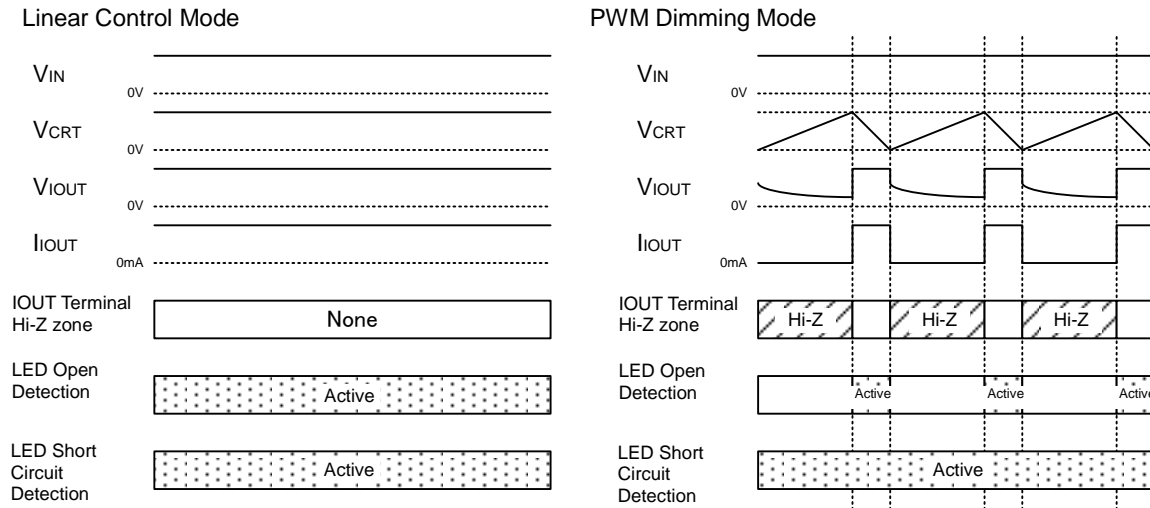

Figure 21. Timing of LED Open & Short Circuit Detection Function and IOOUT Terminal Hi-Z zone

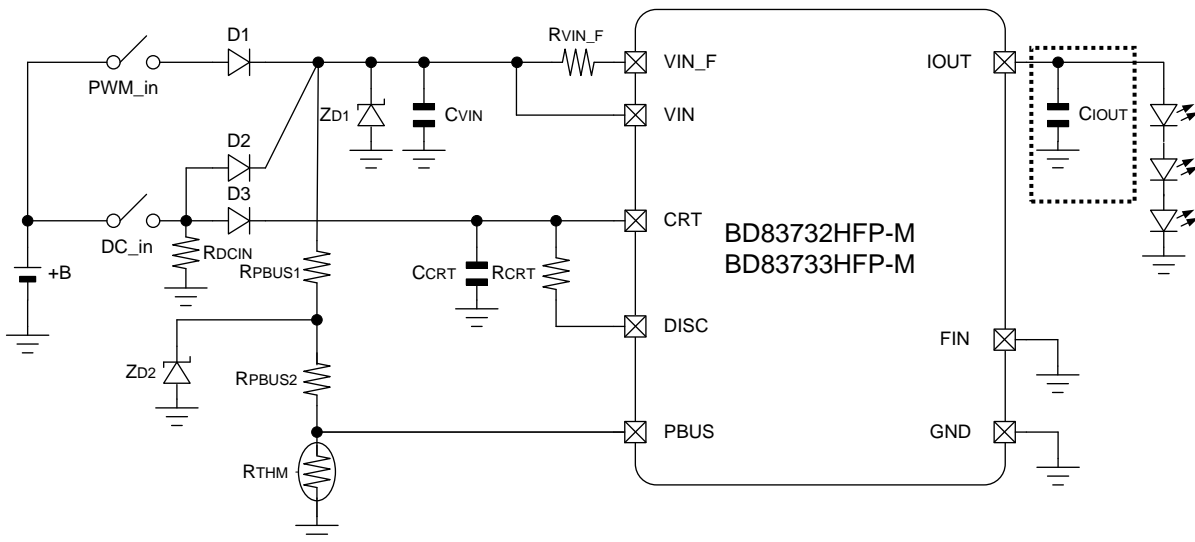
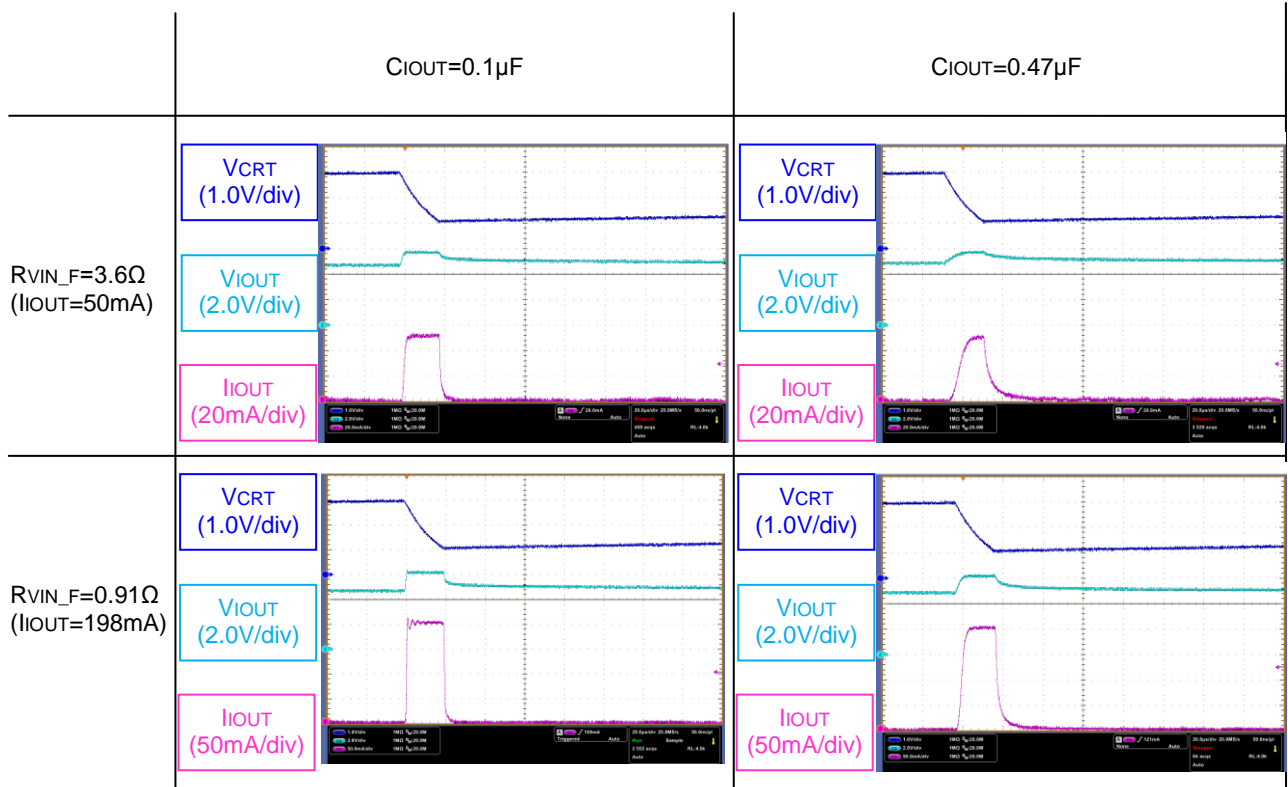

Figure 22. About the capacitor of connecting IOOUT terminal

Evaluation example (I_{OUT} pulse width at PWM Dimming operation)

Condition : +B=13V
 Ta=25°C
 LED 3Strings
 R_{CRT}=560Ω
 C_{CRT}=0.033μF
 PWM Dimming Mode



(5) About the maximum value of the capacitor connected to the output

In case a capacitor exceeding the recommended range (above 0.66μF) is connected to the I_{OUT} terminal, there is a possibility that delay time of start-up will reach about several hundred ms, so special attention is needed. Below an evaluation example is mentioned as reference data.

Measurement conditions : V_{IN}=13V , Ta=25°C, R_{VIN_F}=3.6Ω , LED 3 steps, linear control mode

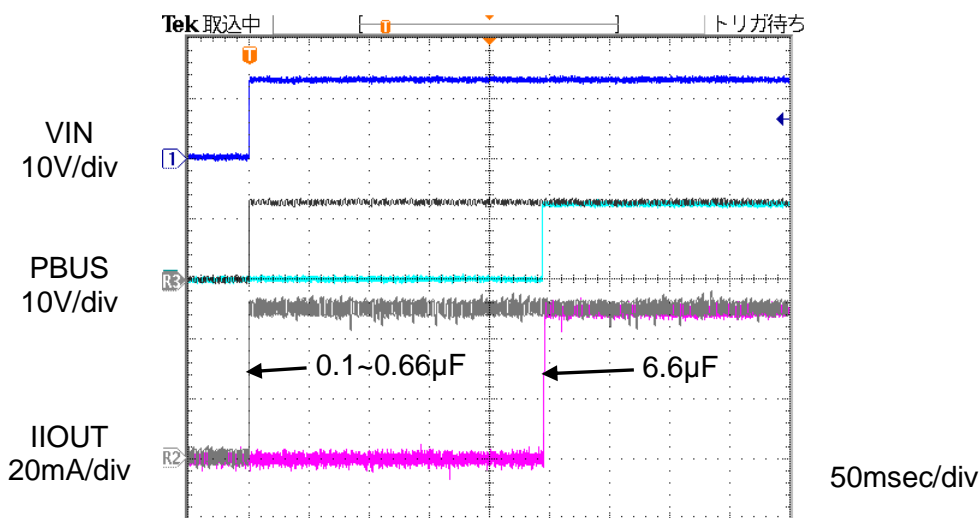

Figure 23. About the capacitor connected to the I_{OUT} terminal

6. PBUS Function

The PBUS terminal is an input/output terminal for outputting trouble and inputting trouble detection. When an LED open/short-circuit occurs, the PBUS terminal output is pulled LOW (Note1). It is possible to turn output current OFF by pulling the PBUS terminal Low.

(Note1) PBUS terminal is an open drain terminal. It should always be pulled up(10kΩ) to power supply voltage.

When multiple ICs are used to drive multiple LEDs, as shown in the drawing below, it is possible to turn off all rows of LEDs if only some LEDs are short/open-circuited by connecting PBUS terminal of each IC.

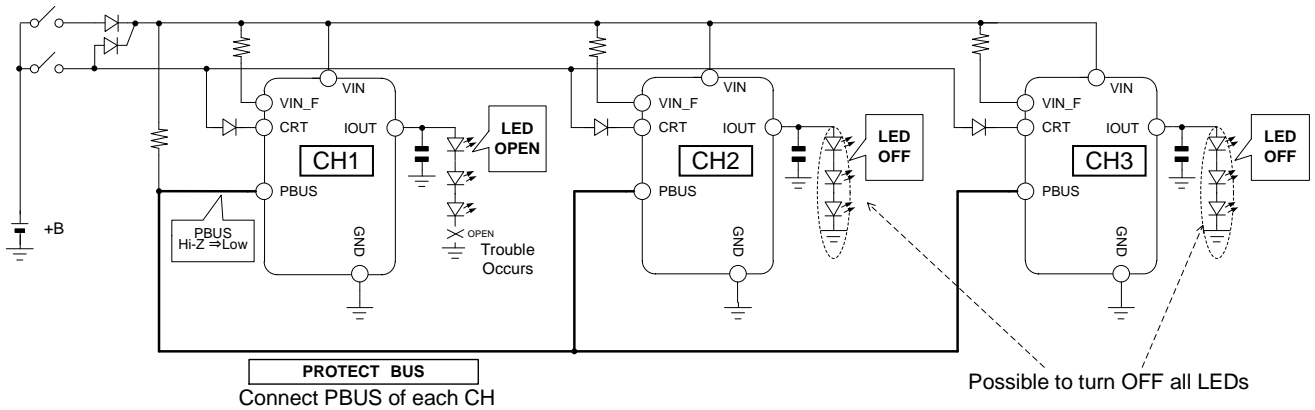

Figure 24. PBUS Function

▼ Example of Protective Operation due to LED Open Circuit

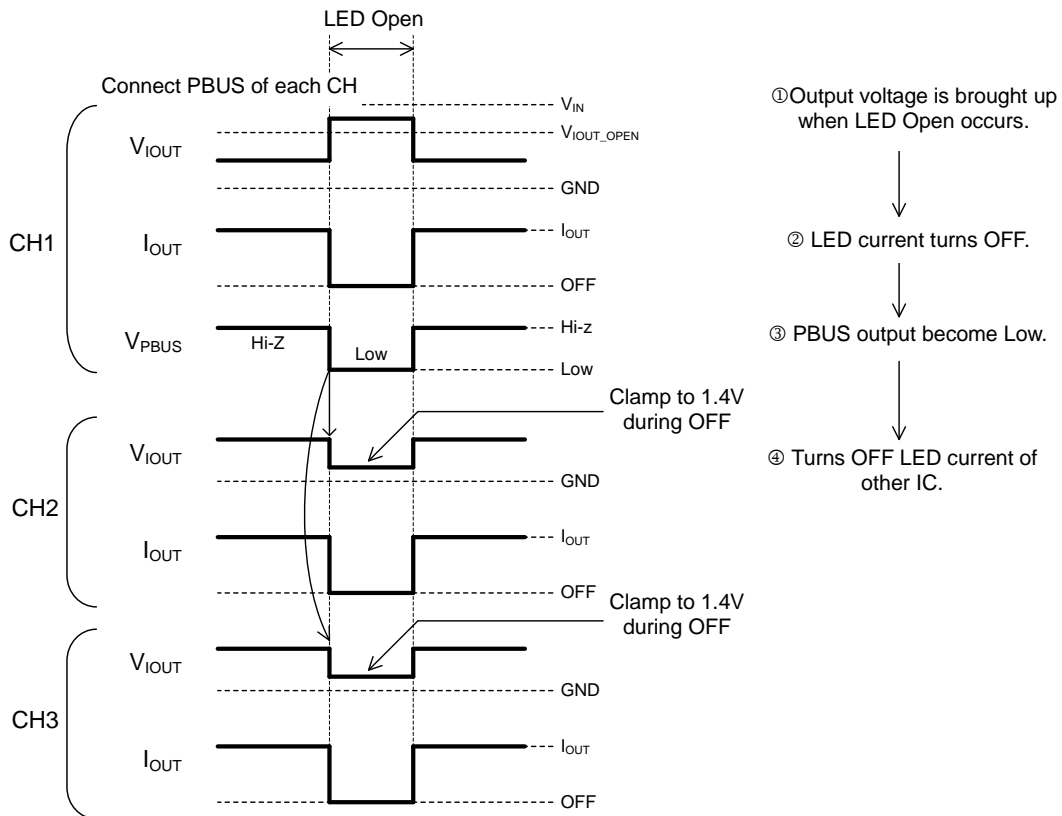

Figure 25. Example of Protective Operation

If LED OPEN occurs, PBUS of CH1 is switched from Hi-Z to Low output. As PBUS becomes Low, LED drivers of other CH detect the condition and turns OFF their own LEDs. VIOOUT clamps to 1.4V (Typ) during the OFF period, in order to prohibit ground fault detection.

7. Caution when using multiple IC with different power supplies

Each Input terminal has a built- in ESD protection diodes. (Refer to I/O equivalence circuits)

If the VIN terminal is not supplied and other Input terminals are supplied voltage, the IC may malfunction(abnormal operation mode, abnormal LED lighting) due to arise VIN terminal voltage .

The Application Example of accidental operation is below.

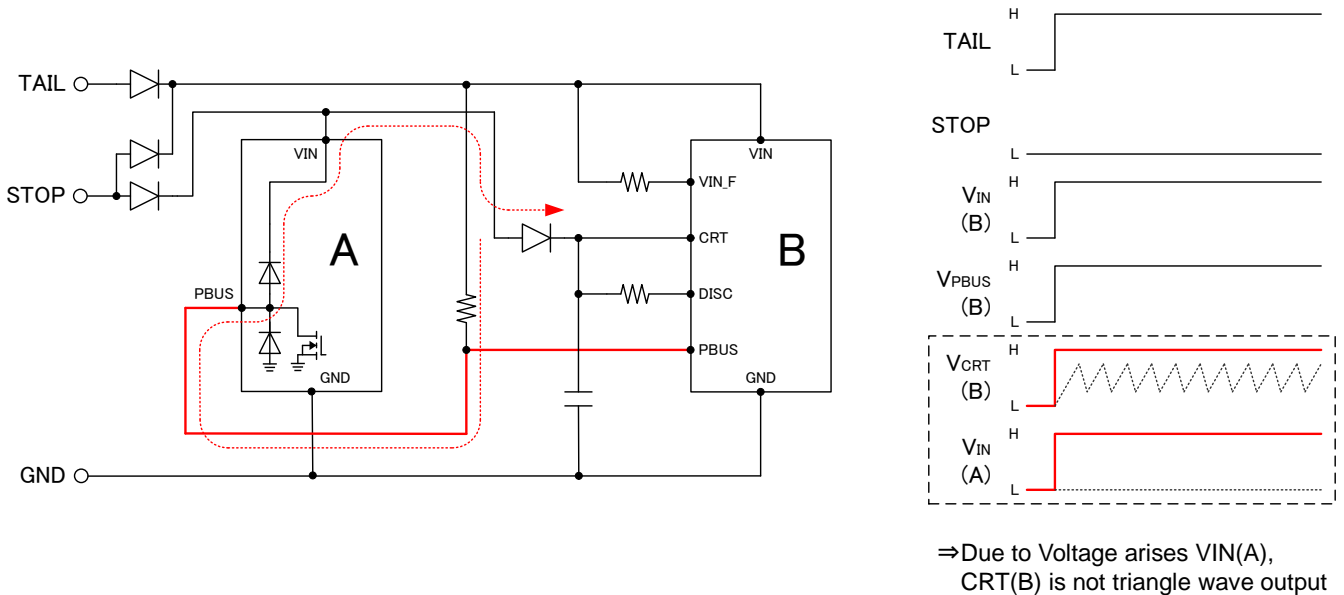

Figure 26. Application Example

(Operational Explanation)

Only input Tail : Arise VIN terminal voltage of IC A from ESD protection Diode between VIN terminal and PBUS terminal of IC A.
 Due to connect VIN terminal of IC A and CRT terminal of IC B across Diode, DC voltage inputs CRT terminal of IC B, so it is possible to operate IC B DC mode.

8. LED current de-rating function

BD83733/32 has an LED current de-rating functionality. When the PBUS terminal voltage falls below 2.5V(Typ), LED current output decreases with VIN_F_REF voltage reduction. In order to eliminate oscillating of the output current, a capacitor is required at the PBUS terminal.

Besides, in case of connecting the PBUS terminals between the series model BD8371XXX/BD8372XXX/BD8374XXX and the BD83733/32HFP-M, the series model except BD83733/32 will be turned off during the de-rating operation.

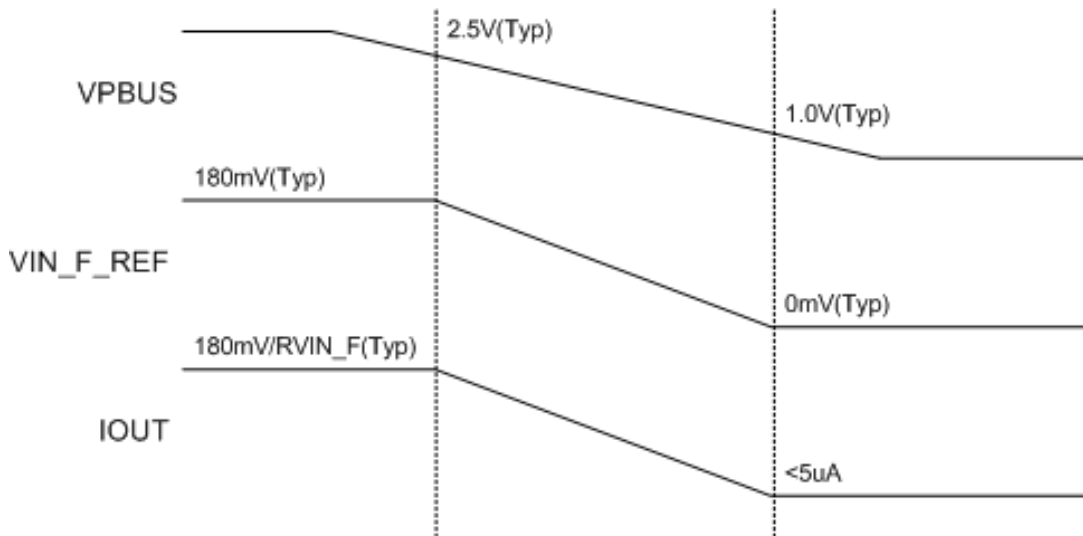

Figure 27. LED Current De-rating Function Characteristics

Timing Chart

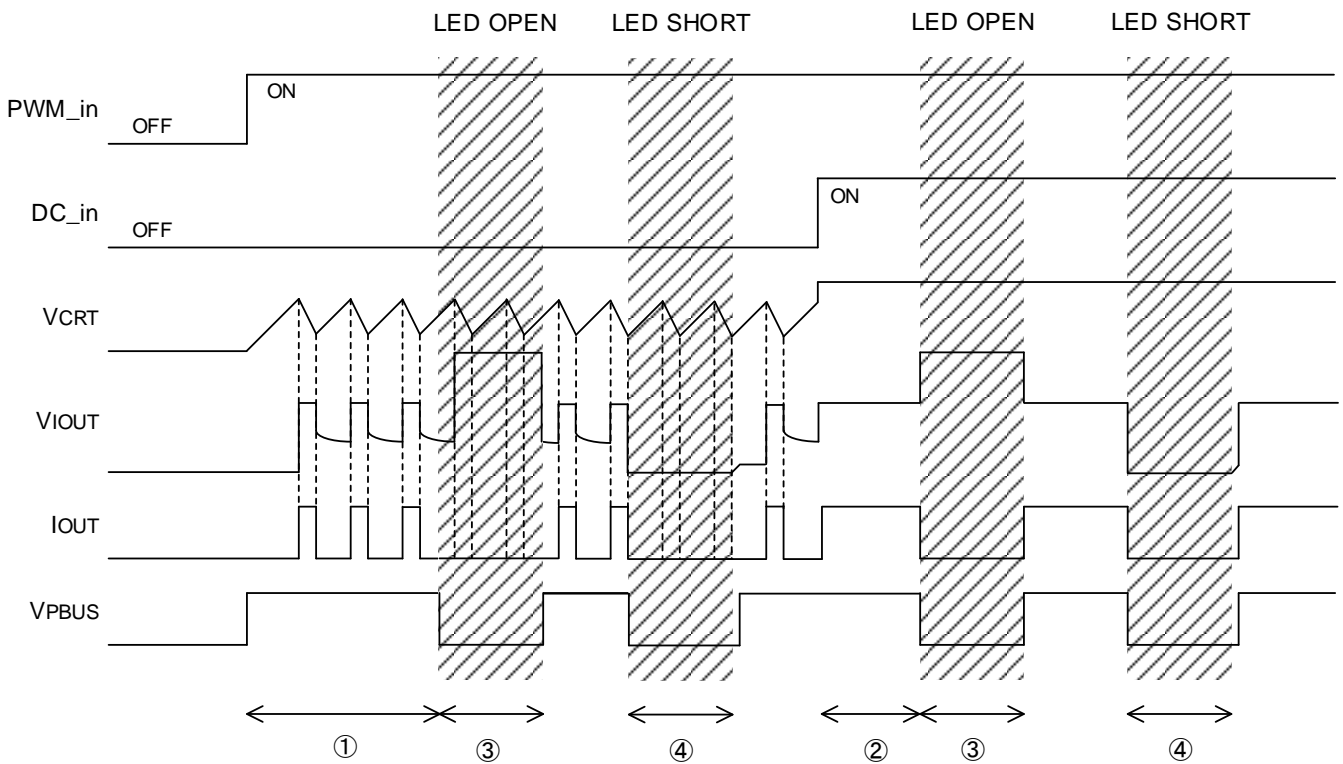
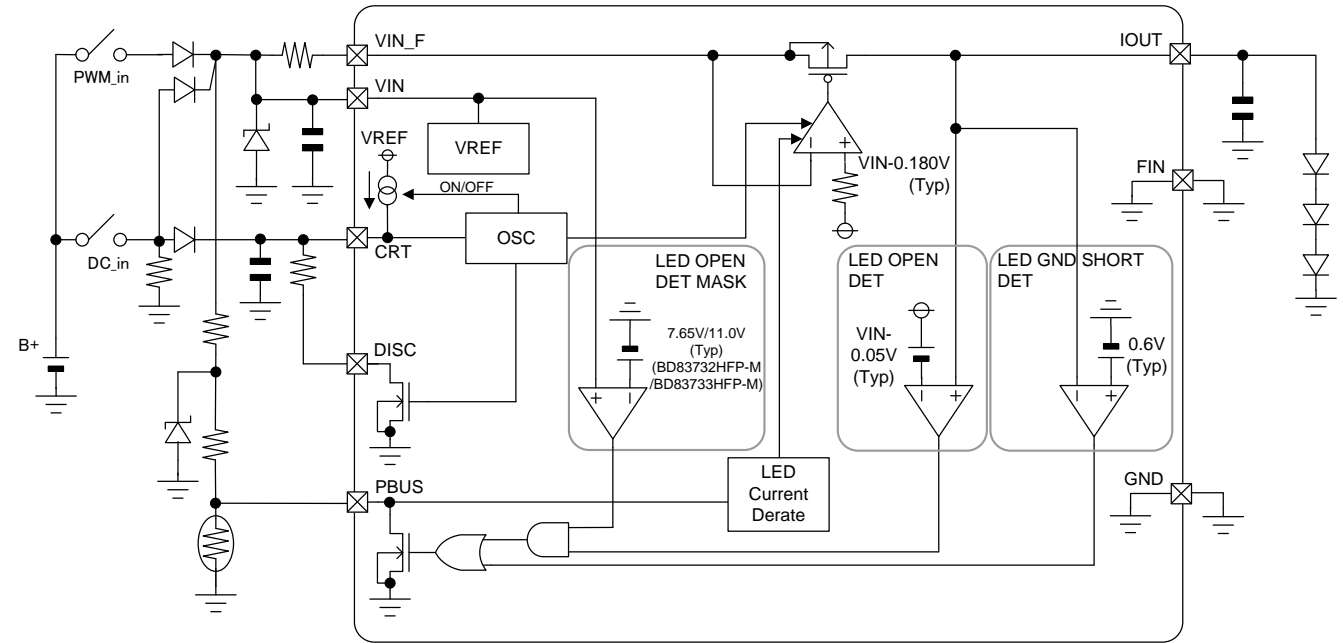

Figure 28. Timing Chart

- ① If PWM_in is switched ON, VCRT will start oscillation, and LED current IOUT will follow this waveform. (PWM light control mode)
- ② If DC_in is switched ON, VCRT will be pulled High (VIN-Vf). LED current IOUT will be continuous. (Linear control mode)
- ③ If LED becomes OPEN, LED current IOUT will stop. At the same time, VPBUS goes Low.
- ④ If LED is short-circuited to GND, LED current IOUT will stop. At the same time, VPBUS goes Low.

Operation Range of Constant Current Control

Operation range of constant current control can be obtained from the following equation:

Operation range of constant current control
 $V_{IN} \geq V_{f_led} \times N + V_{IN_F_REF} + V_{DR_IOUT} [V]$

Where:

V_{IN} is the V_{IN} Terminal Voltage

V_{f_led} is the LED V_f

N is the: Number of LED Levels

$V_{IN_F_REF}$ is the V_{IN_F} Terminal Voltage ($V_{IN} - V_{IN_F}$)

V_{DR_IOUT} is the I_{OOUT} Terminal Drop Voltage

LED Open Detection / Disable LED Open Detection range

This feature is implemented to detect a significant power supply voltage drop at start-up and shut-down, and to disable LED open detection. In case of low power supply (V_{IN}) close to LED forward voltage (V_{IOUT}), the device disables the diagnostic function of LED open to avoid any false open load detection.

At enough power supply higher than the V_{M_OPEN} (threshold of disable LED open detection), when the I_{OOUT} terminal (V_{IOUT}) exceeds the V_{IOUT_OPEN} (LED open detection threshold) by actual LED open load , the P_{BUS} output will be Low.

The LED forward voltage has to be set lower than the V_{M_OPEN} as following equation.

$V_{M_OPEN} \geq V_{f_led} \times N + 50mV(typ) + V_{DR_IOUT} [V]$

LED Open Detection Voltage at I_{OOUT}

$V_{IOUT_OPEN} = V_{IN} - 50mV(Typ)$

Disable LED Open Detection at V_{IN} voltage

BD83732HFP-M : $V_{M_OPEN} = 7.65V (Typ)$

BD83733HFP-M : $V_{M_OPEN} = 11.0V (Typ)$

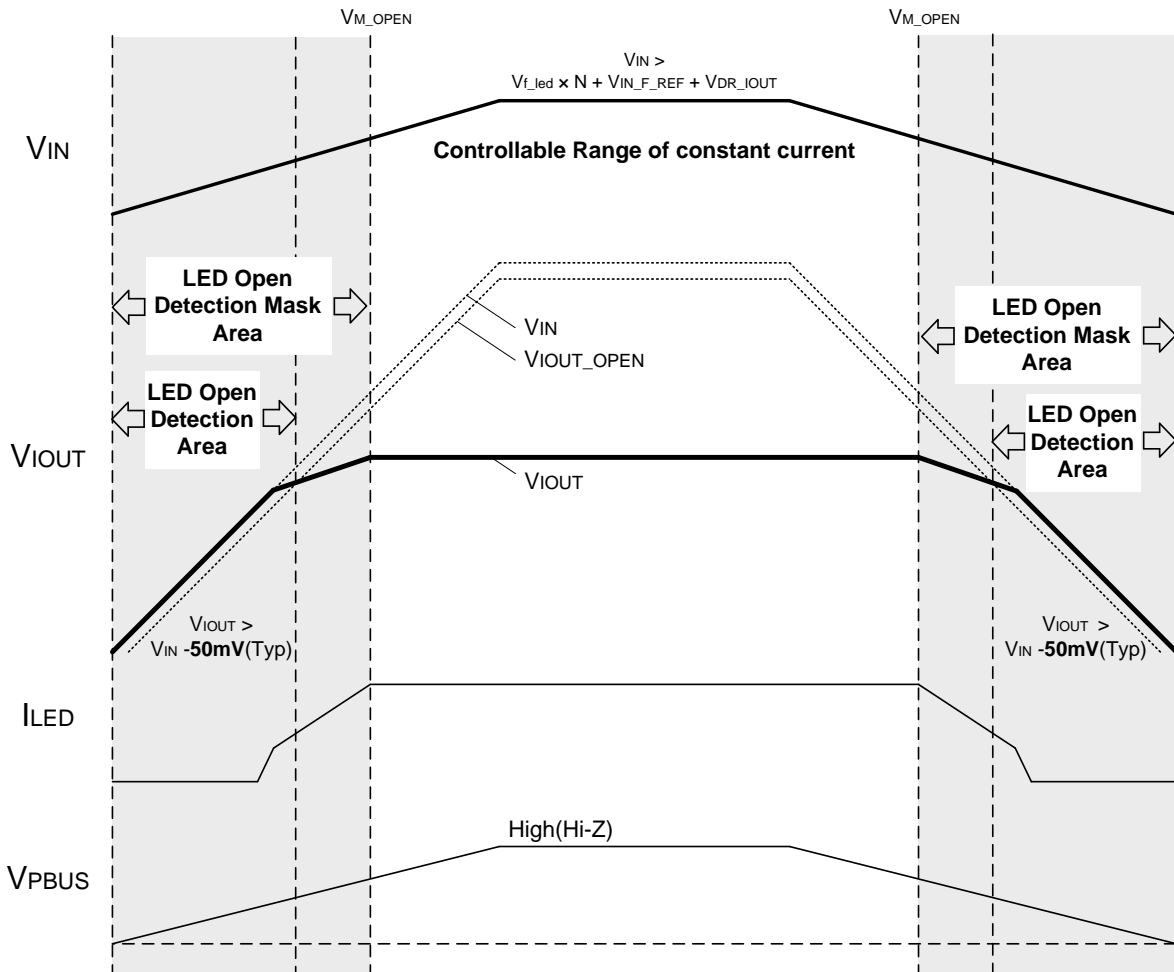

Figure 29. Guaranteed Range of Current Accuracy and LED Open Detection / Disable LED Open Detection range.

How to Connect LED

If multiple rows of LEDs are connected, note that OPEN circuit may not be detected.

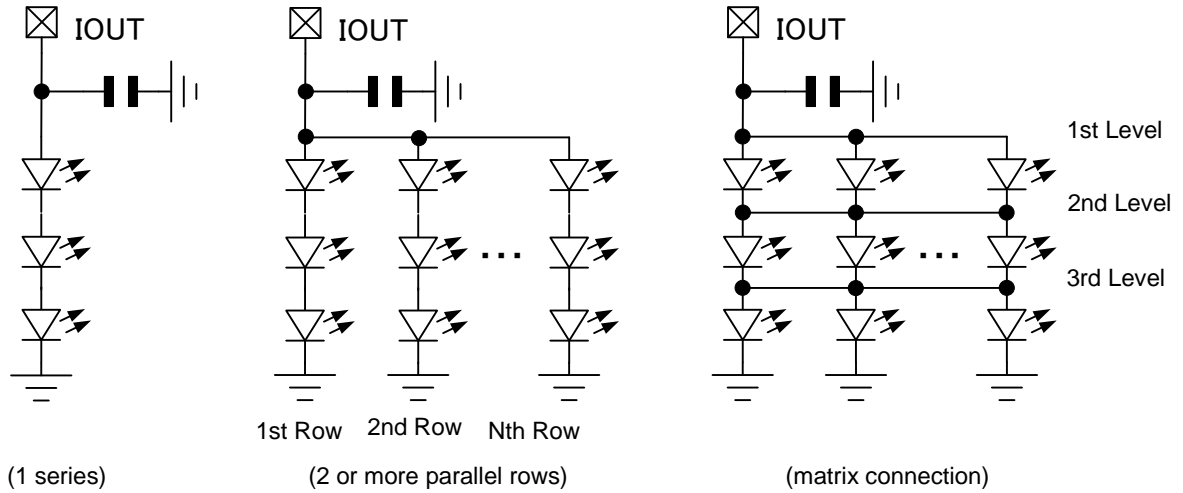

Figure 30. LED Connection Patterns

Connection Pattern	LED Short-circuit Detection (GND short of IOUT terminal)	LED OPEN detection
1 Series	Detectable	Detectable-
2 parallels or more	Detectable	Non-detectable ^(Note 1)
2 parallels or more (Matrix Connection)	Detectable	Non-detectable ^(Note 2)

(Note1) : Detectable only when one or more LEDs become open in all rows.

(Note2) : Detectable only when all LEDs on the same level become open.

Recommended Application Circuit

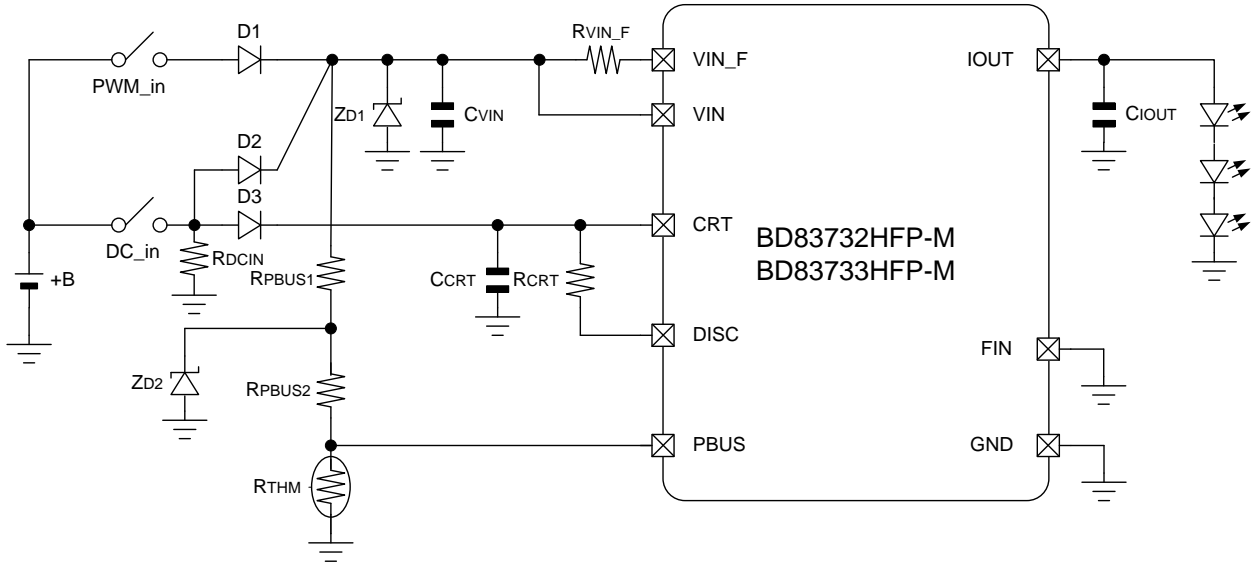

Figure 31. Recommended Application Circuit

No.	Component Name	Component Value	Product Name	Company
1	D1	-	RFN1L6S	ROHM
2	D2	-	RFN1L6S	ROHM
3	D3	-	RFN1L6S	ROHM
4	ZD1	-	TNR12H-220K	NIPPON CHEMICON
5	ZD2	-	FTZ5.6E	ROHM
6	CVIN	4.7μF	GCM32ER71H475KA40	murata
7	RVIN_F	0.91Ω	LTR10 Series	ROHM
8	RPBUS1	1kΩ	ESR03 Series	ROHM
9	RPBUS2	13kΩ	ESR03 Series	ROHM
10	CCRT	0.033μF	GCM188R11H333KA40	murata
11	RCRT	3.9kΩ	MCR03 Series	ROHM
12	CIOUT	0.1μF	GCM188R11H104KA42	murata
13	RTHM	150kΩ	NTCG104LH154H	TDK
14	RDCIN	5.1kΩ	ESR03 Series	ROHM

Table 1. BOM List

PWM_in	DC_in	Mode
Low	Low	OFF
High	Low	PWM Dimming Mode (Note1, Note2) (13.25mA 6.7% ON duty @518Hz)
Low	High	Linear Control Mode (Note2) (197.8mA 100% ON duty)
High	High	Linear Control Mode (Note2) (197.8mA 100% ON duty)

(Note1) See Functional Description "3. PWM Dimming Operation."

(Note2) See Functional Description "2. Table of Operations."

Table 2. Table of Operations

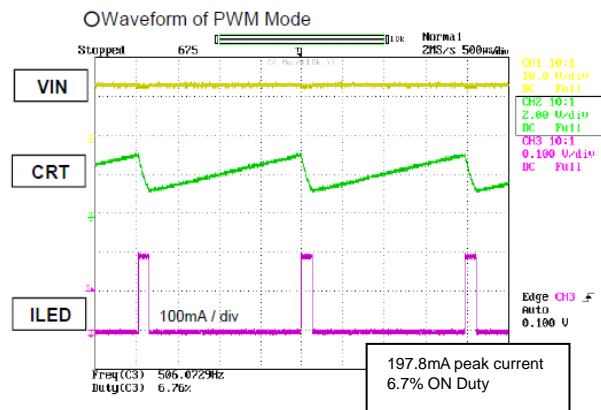

Figure 32. Example of Waveform Measurement

Thermal Loss

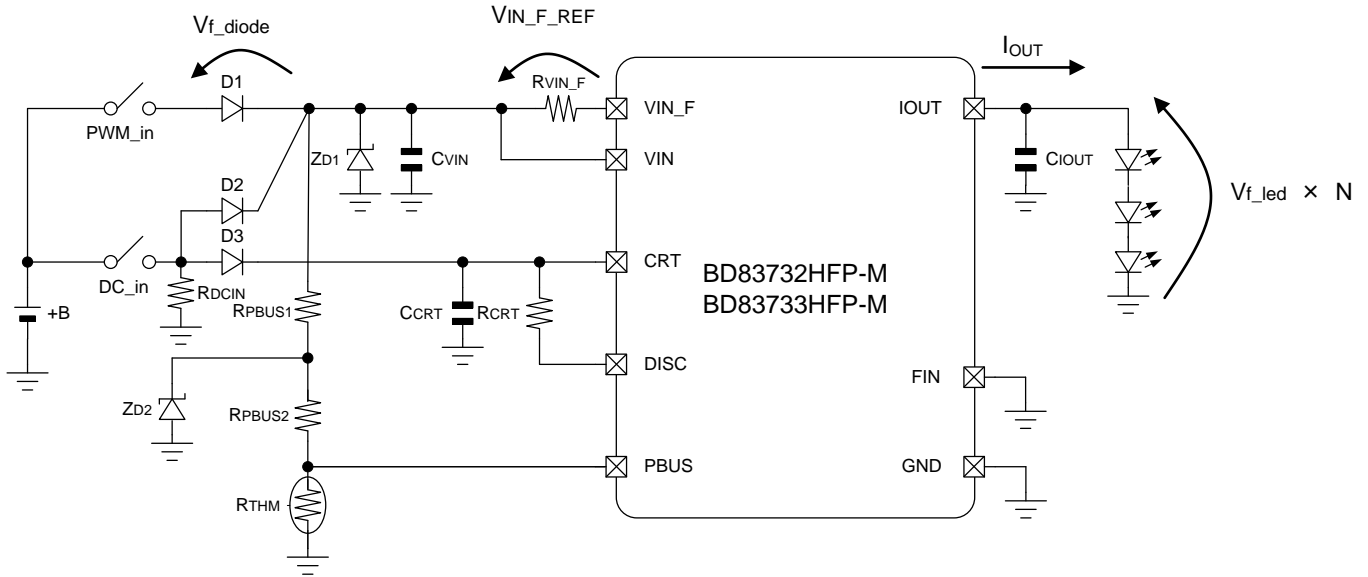

Figure 33. Application Circuit Diagram for Thermal Description

Thermal design should meet the following equation:

$$P_d > P_c$$

$$P_d = (1/\theta_{ja}) \times (T_{jmax} - T_a) \text{ or } (1/\theta_{jc}) \times (T_{jmax} - T_c)$$

$$P_c = (+B - V_{f_diode} - V_{IN_F_REF} - V_{f_led} \times N) \times I_{OUT} + I_{VIN} \times V_{IN}$$

where:

P_d is the Power Dissipation

P_c is the Power Consumption

$+B$ is the Battery Voltage

V_{f_diode} is the Reverse Connection Preventing Diode Vf

$V_{IN_F_REF}$ is the V_{IN_F} Terminal Voltage ($V_{IN} - V_{IN_F}$)

V_{f_led} is the LED Vf

N is the Number of LED Levels

I_{OUT} is the Output Current

I_{VIN} is the Circuit Current

V_{IN} is the Power Supply Voltage

θ_{ja} is the Thermal Resistance between T_j and T_a

θ_{jc} is the Thermal Resistance between T_j and T_c

T_{jmax} is the Max Joint Temperature (150°C)

T_a is the Ambient Temperature

T_c is the Case Surface Temperature

HRP7 Package

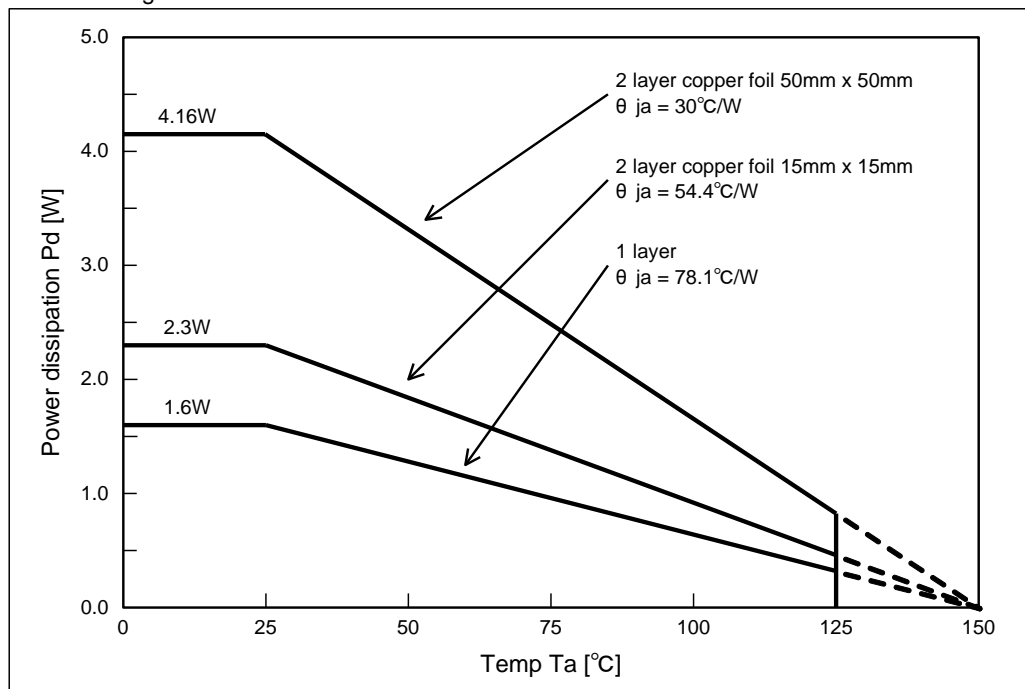

- (Caution1) When mounted with 70.0mm X 70.0mm X 1.6mm glass epoxy substrate.
- (Caution2) Above copper foil area indicates backside copper foil area.
- (Caution3) Value changes according to number of substrate layers and copper foil area. Note that this value is a measured value, not a guaranteed value.

Figure 34. Thermal Dissipation Curve

Thermal Design for Small Number of LEDs

If there are few LED lamps, it is suggested to insert resistance between IOOUT terminal and LED to reduce heat generation in the IC and dissipate heat.
 (This does not apply where amperage is low.)
 In that case, the range of current accuracy will be as shown in the following equation:

$$+B \geq V_{f_diode} + V_{f_led} \times N + V_{IN_F_REF} + V_{DR_IOUT} + I_{OUT} \times R1$$

- V_{f_{diode}} is the Reverse Connection Preventing Diode V_f
- V_{f_{led}} is the LED V_f
- N is the Number of LED Levels
- V_{IN_F_REF} is the VIN_F Terminal Voltage (V_{IN} - V_{IN_F})
- V_{DR_{IOUT}} is the IOOUT Terminal Drop Voltage
- I_{OUT} is the Output Current
- R1 is the Thermal Dissipation Resistance

Thermal design should meet the following equation when inserting thermal dissipation resistance:

$$P_d = (1/\theta_{ja}) \times (T_{jmax} - T_a) \text{ or } (1/\theta_{jc}) \times (T_{jmax} - T_c)$$

$$P_c = (+B - V_{f_diode} - V_{IN_F_REF} - V_{f_led} \times N - I_{OUT} \times R1) \times I_{OUT} + I_{VIN} \times V_{IN}$$

- P_d is the Power Dissipation
- P_c is the Power Consumption
- +B is the Battery Voltage
- V_{f_{diode}} is the Reverse Connection Preventing Diode V_f
- V_{IN_F_REF} is the VIN_F Terminal Voltage (V_{IN} - V_{IN_F})
- V_{f_{led}} is the LED V_f
- N is the Number of LED Levels
- I_{OUT} is the Output Current
- R1 is the Thermal Dissipation Resistance
- I_{VIN} is the Circuit Current
- V_{IN} is the Power Supply Voltage
- θ_{ja} is the Thermal Resistance between T_j and T_a
- θ_{jc} is the Thermal Resistance between T_j and T_c
- T_{jmax} is the Max Joint Temperature (150°C)
- T_a is the Ambient Temperature
- T_c is the Case Surface Temperature

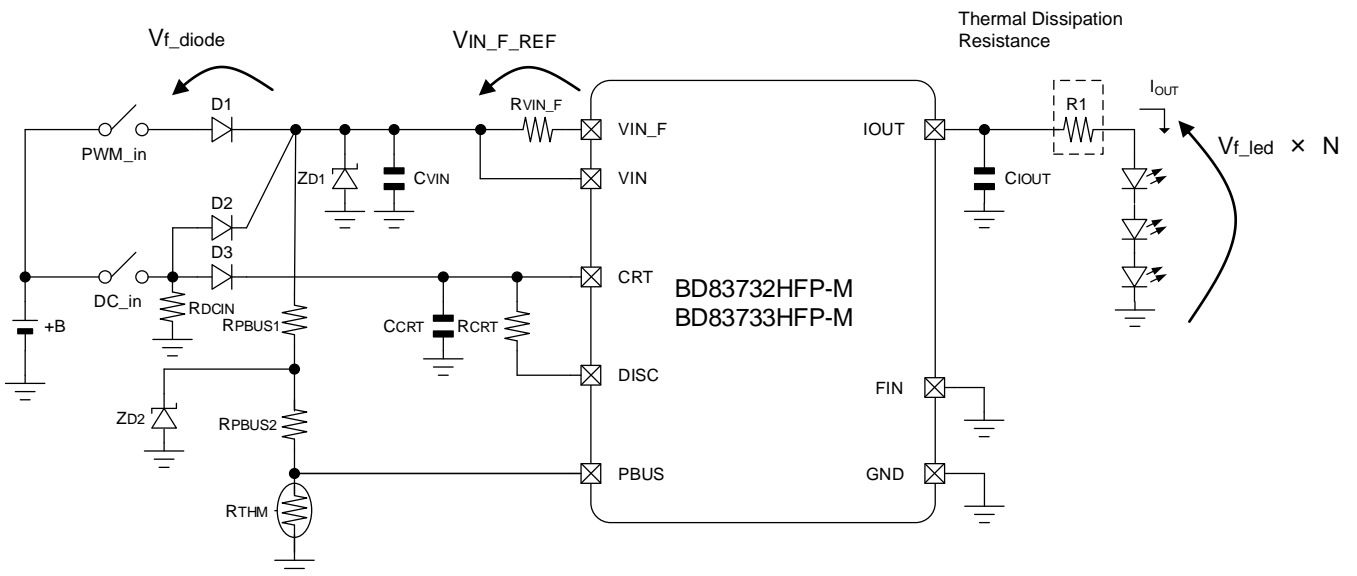

Figure 35. Example of How to Connect Thermal Dissipation Resistance

I/O equivalence circuits

Number	Terminal Name	Equivalence Circuit
1	PBUS	
2	DISC	
3	CRT	
4	GND	-
5	IOUT	
6	VIN_F	
7	VIN	-

Operational Notes

1. Reverse Connection of Power Supply

Connecting the power supply in reverse polarity can damage the IC. Take precautions against reverse polarity when connecting the power supply, such as mounting an external diode between the power supply and the IC's power supply terminals.

2. Power Supply Lines

Design the PCB layout pattern to provide low impedance supply lines. Separate the ground and supply lines of the digital and analog blocks to prevent noise in the ground and supply lines of the digital block from affecting the analog block. Furthermore, connect a capacitor to ground at all power supply pins. Consider the effect of temperature and aging on the capacitance value when using electrolytic capacitors.

3. Ground Voltage

Ensure that no pins are at a voltage below that of the ground pin at any time, even during transient condition.

4. Ground Wiring Pattern

When using both small-signal and large-current ground traces, the two ground traces should be routed separately but connected to a single ground at the reference point of the application board to avoid fluctuations in the small-signal ground caused by large currents. Also ensure that the ground traces of external components do not cause variations on the ground voltage. The ground lines must be as short and thick as possible to reduce line impedance.

5. Thermal Consideration

Should by any chance the power dissipation rating be exceeded the rise in temperature of the chip may result in deterioration of the properties of the chip. The absolute maximum rating of the Pd stated in this specification is when the IC is mounted on a 70mm x 70mm x 1.6mm glass epoxy board. In case of exceeding this absolute maximum rating, increase the board size and copper area to prevent exceeding the Pd rating.

6. Recommended Operating Conditions

These conditions represent a range within which the expected characteristics of the IC can be approximately obtained. The electrical characteristics are guaranteed under the conditions of each parameter.

7. Rush Current

When power is first supplied to the IC, it is possible that the internal logic may be unstable and inrush current may flow instantaneously due to the internal powering sequence and delays, especially if the IC has more than one power supply. Therefore, give special consideration to power coupling capacitance, power wiring, width of ground wiring, and routing of connections.

8. Operation Under Strong Electromagnetic Field

Operating the IC in the presence of a strong electromagnetic field may cause the IC to malfunction.

9. Testing on Application Boards

When testing the IC on an application board, connecting a capacitor directly to a low-impedance output pin may subject the IC to stress. Always discharge capacitors completely after each process or step. The IC's power supply should always be turned off completely before connecting or removing it from the test setup during the inspection process. To prevent damage from static discharge, ground the IC during assembly and use similar precautions during transport and storage.

10. Inter-pin Short and Mounting Errors

Ensure that the direction and position are correct when mounting the IC on the PCB. Incorrect mounting may result in damaging the IC. Avoid nearby pins being shorted to each other especially to ground, power supply and output pin. Inter-pin shorts could be due to many reasons such as metal particles, water droplets (in very humid environment) and unintentional solder bridge deposited in between pins during assembly to name a few.

Operational Notes – continued

11. Unused Input Terminals

Input terminals of an IC are often connected to the gate of a MOS transistor. The gate has extremely high impedance and extremely low capacitance. If left unconnected, the electric field from the outside can easily charge it. The small charge acquired in this way is enough to produce a significant effect on the conduction through the transistor and cause unexpected operation of the IC. So unless otherwise specified, unused input terminals should be connected to the power supply or ground line.

12. Regarding the Input Pin of the IC

This monolithic IC contains P+ isolation and P substrate layers between adjacent elements in order to keep them isolated. P-N junctions are formed at the intersection of the P layers with the N layers of other elements, creating a parasitic diode or transistor. For example (refer to figure below):

When GND > Pin A and GND > Pin B, the P-N junction operates as a parasitic diode.
 When GND > Pin B, the P-N junction operates as a parasitic transistor.

Parasitic diodes inevitably occur in the structure of the IC. The operation of parasitic diodes can result in mutual interference among circuits, operational faults, or physical damage. Therefore, conditions that cause these diodes to operate, such as applying a voltage lower than the GND voltage to an input pin (and thus to the P substrate) should be avoided.

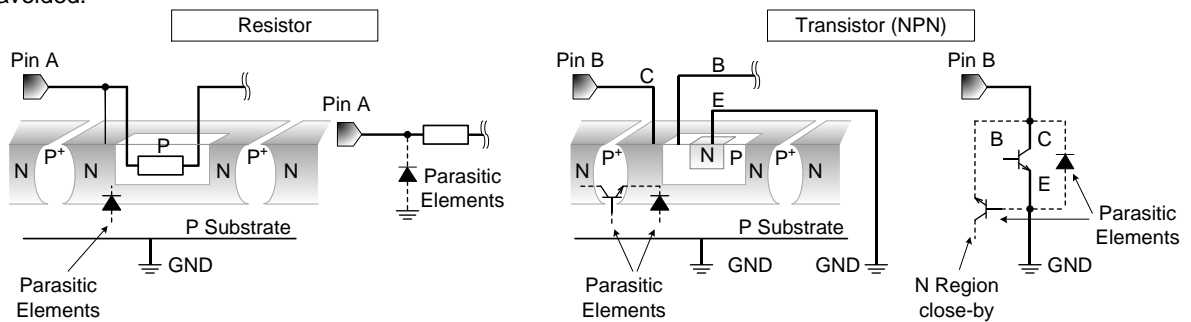

Figure 36. Example of monolithic IC structure

13. Ceramic Capacitor

When using a ceramic capacitor, determine the dielectric constant considering the change of capacitance with temperature and the decrease in nominal capacitance due to DC bias and others.

14. Area of Safe Operation (ASO)

Operate the IC such that the output voltage, output current, and power dissipation are all within the Area of Safe Operation (ASO).

15. Thermal Shutdown Circuit(TSD)

This IC has a built-in thermal shutdown circuit that prevents heat damage to the IC. Normal operation should always be within the IC's power dissipation rating. If however the rating is exceeded for a continued period, the junction temperature (Tj) will rise which will activate the TSD circuit that will turn OFF all output pins. When the Tj falls below the TSD threshold, the circuits are automatically restored to normal operation.

Note that the TSD circuit operates in a situation that exceeds the absolute maximum ratings and therefore, under no circumstances, should the TSD circuit be used in a set design or for any purpose other than protecting the IC from heat damage.

16. Input Voltage Fluctuation

In case input voltage fluctuations are fast, there is a possibility that rush current above the rated value will flow into the output MOSFET. Therefore, please, set the capacity value of the capacitor connected to the VIN terminal after paying enough attention to the actual application in accordance with specifications.

Ordering Information

B D 8 3 7 3 2 H F P

Package
HFP:HRP7

MTR

Packaging and forming specification
M: High Reliability Design
TR: Embossed tape and reel
(HRP7)

B D 8 3 7 3 3 H F P

Package
HFP:HRP7

MTR

Packaging and forming specification
M: High Reliability Design
TR: Embossed tape and reel
(HRP7)

Marking Diagrams

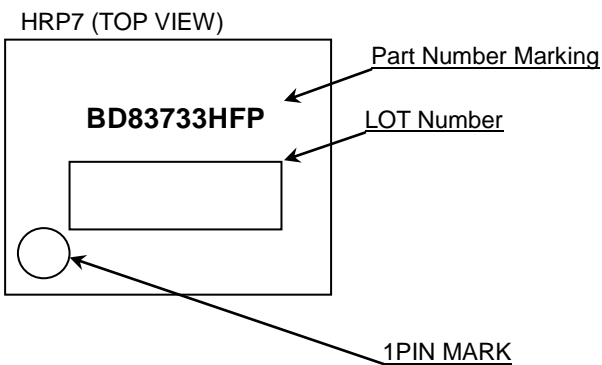
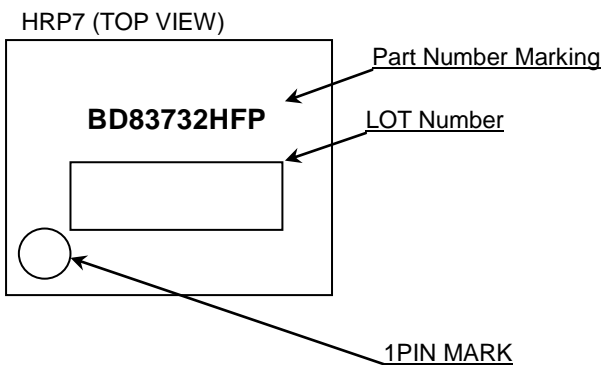

Physical Dimension, Tape and Reel Information

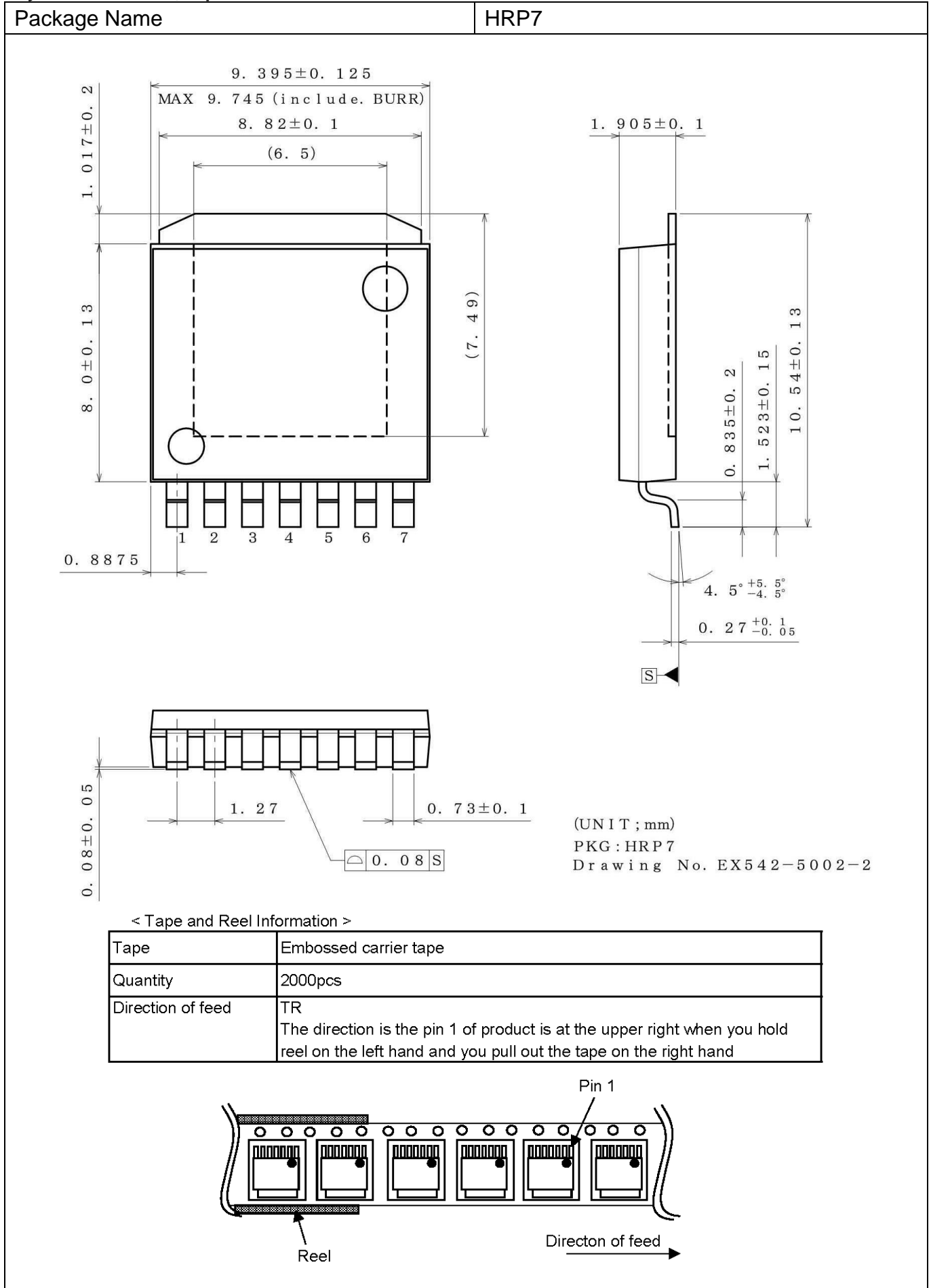

Revision History

Date	Revision	Changes
29.Aug.2014	001	New Release
10.Nov.2014	002	<p>Page.1, 10, 11, 13, 17, 20, 21, 23 Application Circuit revised</p> <p>Page.3 Recommended Operating Conditions Change Rating PWM Minimum Pulse Width 20μs \rightarrow 10μs Change to Operating Conditions Parameter Current Setting Resistor ,Capacitor connecting VIN terminal and Capacitor connecting IOOUT terminal</p> <p>Operating Conditions Add Capacitor connecting CRT terminal and DC_IN pull-down resistor parameter.</p> <p>Page.20 BOM List revised</p>
25.Aug.2016	003	<p>Page 4 Electrical Characteristics IOOUT Voltageat LED Short Detection Typ 0.6\rightarrow0.67</p> <p>Page 8 PWM Dimming Operation change words</p> <p>Page 9 Line 19 1800.7μs \rightarrow 1801.6μs Line 23 $-129\mu\text{sec} / 0.033\mu\text{F} \times \ln(1.1 / 3.0) - 50\Omega$ \downarrow $-129\mu\text{sec} / (0.033\mu\text{F} \times \ln(1.1 / 3.0)) - 50\Omega$</p> <p>Page 23 Line 6 VIN \rightarrow +B Line 16 $P_c = (+B - V_{f_diode} - V_{IN_F_REF} - V_{f_led} \times N) \times I_{OUT} + I_{VIN} \times V_{IN}$ \downarrow $P_c = (+B - V_{f_diode} - V_{IN_F_REF} - V_{f_led} \times N - I_{OUT} \times R1) \times I_{OUT} + I_{VIN} \times V_{IN}$</p> <p>Page 24 I/O equivalence circuits PBUS, CRT revised</p>

Notice

Precaution on using ROHM Products

1. If you intend to use our Products in devices requiring extremely high reliability (such as medical equipment ^(Note 1), aircraft/spacecraft, nuclear power controllers, etc.) and whose malfunction or failure may cause loss of human life, bodily injury or serious damage to property ("Specific Applications"), please consult with the ROHM sales representative in advance. Unless otherwise agreed in writing by ROHM in advance, ROHM shall not be in any way responsible or liable for any damages, expenses or losses incurred by you or third parties arising from the use of any ROHM's Products for Specific Applications.

(Note1) Medical Equipment Classification of the Specific Applications

JAPAN	USA	EU	CHINA
CLASS III	CLASS III	CLASS II b	CLASS III
CLASS IV		CLASS III	

2. ROHM designs and manufactures its Products subject to strict quality control system. However, semiconductor products can fail or malfunction at a certain rate. Please be sure to implement, at your own responsibilities, adequate safety measures including but not limited to fail-safe design against the physical injury, damage to any property, which a failure or malfunction of our Products may cause. The following are examples of safety measures:
 - [a] Installation of protection circuits or other protective devices to improve system safety
 - [b] Installation of redundant circuits to reduce the impact of single or multiple circuit failure
3. Our Products are not designed under any special or extraordinary environments or conditions, as exemplified below. Accordingly, ROHM shall not be in any way responsible or liable for any damages, expenses or losses arising from the use of any ROHM's Products under any special or extraordinary environments or conditions. If you intend to use our Products under any special or extraordinary environments or conditions (as exemplified below), your independent verification and confirmation of product performance, reliability, etc. prior to use, must be necessary:
 - [a] Use of our Products in any types of liquid, including water, oils, chemicals, and organic solvents
 - [b] Use of our Products outdoors or in places where the Products are exposed to direct sunlight or dust
 - [c] Use of our Products in places where the Products are exposed to sea wind or corrosive gases, including Cl₂, H₂S, NH₃, SO₂, and NO₂
 - [d] Use of our Products in places where the Products are exposed to static electricity or electromagnetic waves
 - [e] Use of our Products in proximity to heat-producing components, plastic cords, or other flammable items
 - [f] Sealing or coating our Products with resin or other coating materials
 - [g] Use of our Products without cleaning residue of flux (even if you use no-clean type fluxes, cleaning residue of flux is recommended); or Washing our Products by using water or water-soluble cleaning agents for cleaning residue after soldering
 - [h] Use of the Products in places subject to dew condensation
4. The Products are not subject to radiation-proof design.
5. Please verify and confirm characteristics of the final or mounted products in using the Products.
6. In particular, if a transient load (a large amount of load applied in a short period of time, such as pulse. is applied, confirmation of performance characteristics after on-board mounting is strongly recommended. Avoid applying power exceeding normal rated power; exceeding the power rating under steady-state loading condition may negatively affect product performance and reliability.
7. De-rate Power Dissipation depending on ambient temperature. When used in sealed area, confirm that it is the use in the range that does not exceed the maximum junction temperature.
8. Confirm that operation temperature is within the specified range described in the product specification.
9. ROHM shall not be in any way responsible or liable for failure induced under deviant condition from what is defined in this document.

Precaution for Mounting / Circuit board design

1. When a highly active halogenous (chlorine, bromine, etc.) flux is used, the residue of flux may negatively affect product performance and reliability.
2. In principle, the reflow soldering method must be used on a surface-mount products, the flow soldering method must be used on a through hole mount products. If the flow soldering method is preferred on a surface-mount products, please consult with the ROHM representative in advance.

For details, please refer to ROHM Mounting specification

Precautions Regarding Application Examples and External Circuits

1. If change is made to the constant of an external circuit, please allow a sufficient margin considering variations of the characteristics of the Products and external components, including transient characteristics, as well as static characteristics.
2. You agree that application notes, reference designs, and associated data and information contained in this document are presented only as guidance for Products use. Therefore, in case you use such information, you are solely responsible for it and you must exercise your own independent verification and judgment in the use of such information contained in this document. ROHM shall not be in any way responsible or liable for any damages, expenses or losses incurred by you or third parties arising from the use of such information.

Precaution for Electrostatic

This Product is electrostatic sensitive product, which may be damaged due to electrostatic discharge. Please take proper caution in your manufacturing process and storage so that voltage exceeding the Products maximum rating will not be applied to Products. Please take special care under dry condition (e.g. Grounding of human body / equipment / solder iron, isolation from charged objects, setting of Ionizer, friction prevention and temperature / humidity control).

Precaution for Storage / Transportation

1. Product performance and soldered connections may deteriorate if the Products are stored in the places where:
 - [a] the Products are exposed to sea winds or corrosive gases, including Cl₂, H₂S, NH₃, SO₂, and NO₂
 - [b] the temperature or humidity exceeds those recommended by ROHM
 - [c] the Products are exposed to direct sunshine or condensation
 - [d] the Products are exposed to high Electrostatic
2. Even under ROHM recommended storage condition, solderability of products out of recommended storage time period may be degraded. It is strongly recommended to confirm solderability before using Products of which storage time is exceeding the recommended storage time period.
3. Store / transport cartons in the correct direction, which is indicated on a carton with a symbol. Otherwise bent leads may occur due to excessive stress applied when dropping of a carton.
4. Use Products within the specified time after opening a humidity barrier bag. Baking is required before using Products of which storage time is exceeding the recommended storage time period.

Precaution for Product Label

A two-dimensional barcode printed on ROHM Products label is for ROHM's internal use only.

Precaution for Disposition

When disposing Products please dispose them properly using an authorized industry waste company.

Precaution for Foreign Exchange and Foreign Trade act

Since concerned goods might be fallen under listed items of export control prescribed by Foreign exchange and Foreign trade act, please consult with ROHM in case of export.

Precaution Regarding Intellectual Property Rights

1. All information and data including but not limited to application example contained in this document is for reference only. ROHM does not warrant that foregoing information or data will not infringe any intellectual property rights or any other rights of any third party regarding such information or data.
2. ROHM shall not have any obligations where the claims, actions or demands arising from the combination of the Products with other articles such as components, circuits, systems or external equipment (including software).
3. No license, expressly or implied, is granted hereby under any intellectual property rights or other rights of ROHM or any third parties with respect to the Products or the information contained in this document. Provided, however, that ROHM will not assert its intellectual property rights or other rights against you or your customers to the extent necessary to manufacture or sell products containing the Products, subject to the terms and conditions herein.

Other Precaution

1. This document may not be reprinted or reproduced, in whole or in part, without prior written consent of ROHM.
2. The Products may not be disassembled, converted, modified, reproduced or otherwise changed without prior written consent of ROHM.
3. In no event shall you use in any way whatsoever the Products and the related technical information contained in the Products or this document for any military purposes, including but not limited to, the development of mass-destruction weapons.
4. The proper names of companies or products described in this document are trademarks or registered trademarks of ROHM, its affiliated companies or third parties.

General Precaution

1. Before you use our Products, you are requested to carefully read this document and fully understand its contents. ROHM shall not be in any way responsible or liable for failure, malfunction or accident arising from the use of any ROHM's Products against warning, caution or note contained in this document.
2. All information contained in this document is current as of the issuing date and subject to change without any prior notice. Before purchasing or using ROHM's Products, please confirm the latest information with a ROHM sales representative.
3. The information contained in this document is provided on an "as is" basis and ROHM does not warrant that all information contained in this document is accurate and/or error-free. ROHM shall not be in any way responsible or liable for any damages, expenses or losses incurred by you or third parties resulting from inaccuracy or errors of or concerning such information.

X-ON Electronics

Largest Supplier of Electrical and Electronic Components

Click to view similar products for [LED Lighting Drivers](#) category:

Click to view products by [ROHM](#) manufacturer:

Other Similar products are found below :

[LV5235V-MPB-H](#) [MB39C602PNF-G-JNEFE1](#) [MIC2871YMK-T5](#) [AL1676-10BS7-13](#) [AL1676-20AS7-13](#) [AP5726WUG-7](#) [ICL8201](#)
[IS31BL3228B-UTLS2-TR](#) [IS31BL3506B-TTLS2-TR](#) [AL3157F-7](#) [LV52204MTTBG](#) [AP5725WUG-7](#) [STP4CMPQTR](#) [NCL30086BDR2G](#)
[CAT4004BHU2-GT3](#) [LV52207AXA-VH](#) [AP1694AS-13](#) [TLE4242EJ](#) [AS3688](#) [IS31LT3172-GRLS4-TR](#) [TLD2311EL](#) [KTD2694EDQ-TR](#)
[KTZ8864EJAA-TR](#) [IS32LT3174-GRLA3-TR](#) [MP2488DN-LF-Z](#) [NLM0010XTSA1](#) [AL1676-20BS7-13](#) [ZXLD1370QESTTC](#) [MPQ7220GF-](#)
[AEC1-P](#) [MPQ7220GR-AEC1-P](#) [MPQ4425BGJ-AEC1-P](#) [MPQ7220GF-AEC1-Z](#) [MPQ7220GR-AEC1-Z](#) [MPQ4425BGJ-AEC1-Z](#)
[IS31FL3737B-QFLS4-TR](#) [IS31FL3239-QFLS4-TR](#) [KTD2058EUAC-TR](#) [KTD2037EWE-TR](#) [DIO5662ST6](#) [IS31BL3508A-TTLS2-TR](#)
[KTD2026BEWE-TR](#) [MAX20052CATC/V+](#) [MAX25606AUP/V+](#) [BD6586MUV-E2](#) [BD9206EFV-E2](#) [BD9416FS-E2](#) [LYT4227E](#)
[LYT6079C-TL](#) [MP3394SGF-P](#) [MP4689AGN-P](#)