

# 2.7V to 5.5V, 3A 1ch Synchronous Buck Converter with Integrated FET

**BD8963EFJ**

## General Description

The BD8963EFJ is ROHM's high efficiency step-down switching regulator designed to produce a voltage as low as 1.0V from a supply voltage of 5.5V/3.3V. It offers high efficiency by using synchronous switches and provides fast transient response to sudden load changes by implementing current mode control.

## Features

- Fast Transient Response because of Current Mode Control System
- High Efficiency for All Load Ranges because of Synchronous Switches
- Soft-Start Function
- Thermal Shutdown and UVLO Functions
- Short Circuit Current Protection with Time Delay Function
- Shutdown Function

## Applications

Power Supply for LSI including DSP, Microcomputer and ASIC

## Key Specifications

- |                                |                |
|--------------------------------|----------------|
| ■ Input Voltage Range:         | 2.7V to 5.5V   |
| ■ Output Voltage Range:        | 1.0V to 2.5V   |
| ■ Average Output Current:      | 3.0A (Max)     |
| ■ Switching Frequency:         | 1MHz (Typ)     |
| ■ Pch FET ON-Resistance:       | 145mΩ(Typ)     |
| ■ Nch FET ON-Resistance:       | 80mΩ(Typ)      |
| ■ Standby Current:             | 5.0μA (Typ)    |
| ■ Operating Temperature Range: | -25°C to +85°C |

## Package

W(Typ) x D(Typ) x H(Max)

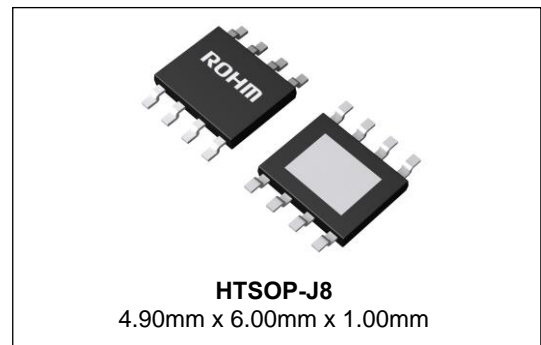

## Typical Application Circuit

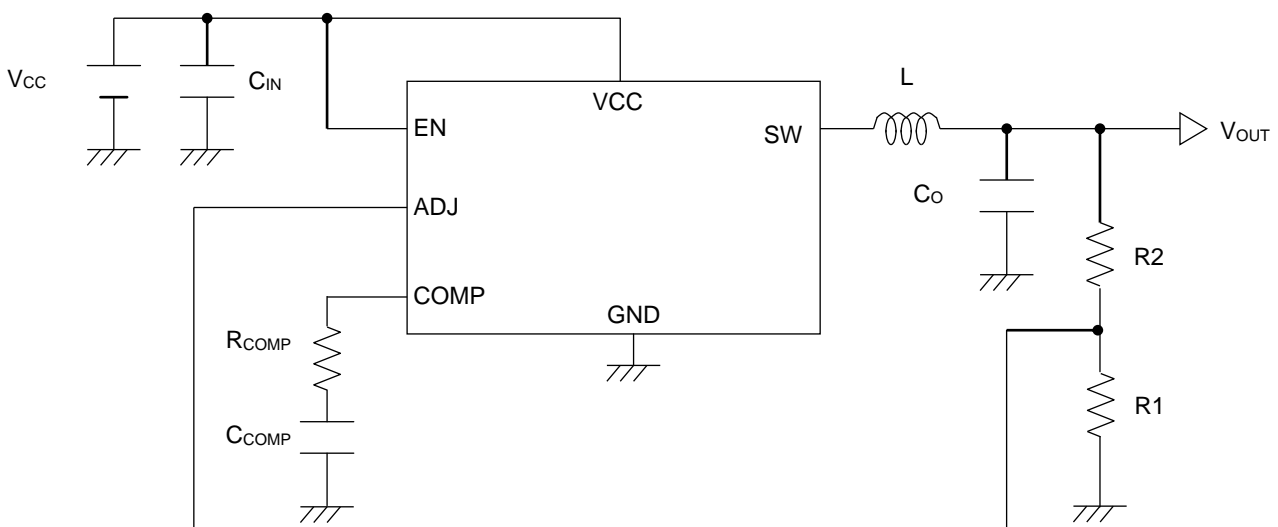

Figure 1. Typical Application Circuit

Pin Configuration

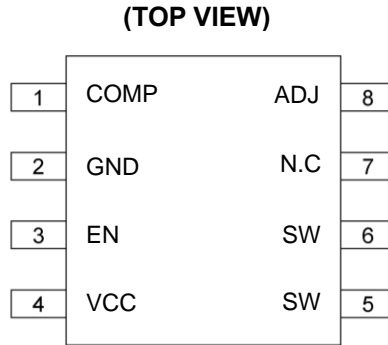

Figure 2. Pin Configuration

Pin Description

Pin No.	Pin Name	Pin Function
1	COMP	GmAmp output pin/connected to phase compensation capacitor
2	GND	Ground pin
3	EN	Enable pin (Active High, Open Active)
4	VCC	Power supply input pin
5	SW	Power switch node
6	SW	Power switch node
7	N.C	No connection
8	ADJ	Output voltage detection pin

Block Diagram

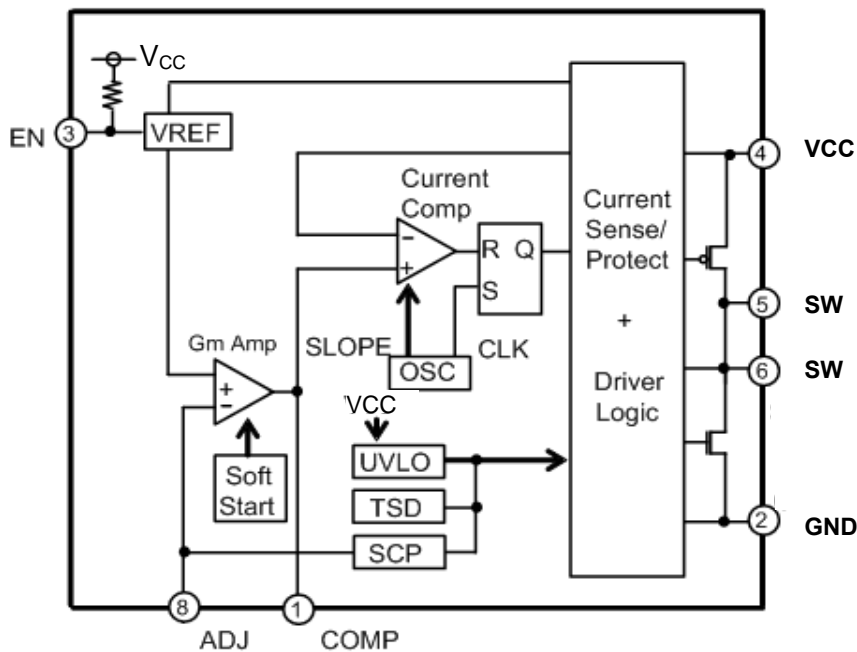

Figure 3. Block Diagram

## Absolute Maximum Ratings

Parameter	Symbol	Rating	Unit
VCC Voltage	V <sub>CC</sub>	-0.3 to +7 (Note 1)	V
EN Voltage	V <sub>EN</sub>	-0.3 to +7	V
SW,COMP Voltage	V <sub>SW</sub> ,V <sub>COMP</sub>	-0.3 to +7	V
Power Dissipation 1	Pd1	0.5 (Note 2)	W
Power Dissipation 2	Pd2	3.76 (Note 3)	W
Operating Temperature Range	T <sub>opr</sub>	-25 to +85	°C
Storage Temperature Range	T <sub>stg</sub>	-55 to +150	°C
Maximum Junction Temperature	T <sub>jmax</sub>	+150	°C

(Note 1) Pd should not be exceeded.

(Note 2) Reduce by 4.0mW/°C for Ta above 25°C.

(Note 3) When mounted on a 4-layer 70.0mm x 70.0mm x 1.6mm Glass-epoxy PCB. Reduce by 30.0mW/°C for Ta above 25°C.

**Caution:** Operating the IC over the absolute maximum ratings may damage the IC. The damage can either be a short circuit between pins or an open circuit between pins and the internal circuitry. Therefore, it is important to consider circuit protection measures, such as adding a fuse, in case the IC is operated over the absolute maximum ratings.

## Recommended Operating Conditions (Ta=-25°C to +85°C)

Parameter	Symbol	Limit			Unit
		Min	Typ	Max	
Power Supply Voltage	V <sub>CC</sub>	2.7 (Note 5)	5.0	5.5	V
EN Voltage	V <sub>EN</sub>	0	-	V <sub>CC</sub>	V
Output Voltage Range	V <sub>OUT</sub>	1.0	-	2.5 (Note 4)	V
SW Average Output Current	I <sub>SW</sub>	-	-	3.0 (Note 5)	A

(Note 4) In case of setting the output voltage to 1.6V or more, V<sub>CCMin</sub>=V<sub>OUT</sub>+2.25V

(Note 5) Pd should not be exceeded.

## Electrical Characteristics

(Unless otherwise specified, Ta=25°C V<sub>CC</sub>=5V, V<sub>EN</sub>=V<sub>CC</sub>, R<sub>1</sub>=20kΩ, R<sub>2</sub>=7.5kΩ)

Parameter	Symbol	Limit			Unit	Conditions
		Min	Typ	Max		
Standby Current	I <sub>STB</sub>	-	5	20	μA	EN=GND
Bias Current	I <sub>CC</sub>	-	350	600	μA	
EN Low Voltage	V <sub>ENL</sub>	-	GND	0.3	V	Standby mode
EN High Voltage	V <sub>ENH</sub>	2.0	V <sub>CC</sub>	-	V	Active mode
EN Current	I <sub>EN</sub>	-	1.25	10	μA	V <sub>EN</sub> =5V
Oscillation Frequency	f <sub>OSC</sub>	0.8	1	1.2	MHz	
Pch FET ON-Resistance	R <sub>ONP</sub>	-	145	290	mΩ	V <sub>CC</sub> =5V
Nch FET ON-Resistance	R <sub>ONN</sub>	-	80	160	mΩ	V <sub>CC</sub> =5V
ADJ Reference Voltage	V <sub>ADJ</sub>	0.788	0.800	0.812	V	
COMP Sink Current	I <sub>COMP SI</sub>	10	25	-	μA	V <sub>ADJ</sub> =1.0V
COMP Source Current	I <sub>COMP SO</sub>	10	25	-	μA	V <sub>ADJ</sub> =0.6V
UVLO Threshold Voltage	V <sub>UVLO1</sub>	2.400	2.500	2.600	V	V <sub>CC</sub> =5V to 0V
UVLO Hysteresis Voltage	V <sub>UVLO2</sub>	2.425	2.550	2.700	V	V <sub>CC</sub> =0V to 5V
Soft Start Time	t <sub>SS</sub>	0.5	1	2	ms	
Timer Latch Time	t <sub>LATCH</sub>	1	2	4	ms	
Output Short Circuit Threshold Voltage	V <sub>SCP</sub>	-	V <sub>OUT</sub> ×0.5	V <sub>OUT</sub> ×0.7	V	V <sub>OUT</sub> =1.0V to 0V

Typical Performance Curves

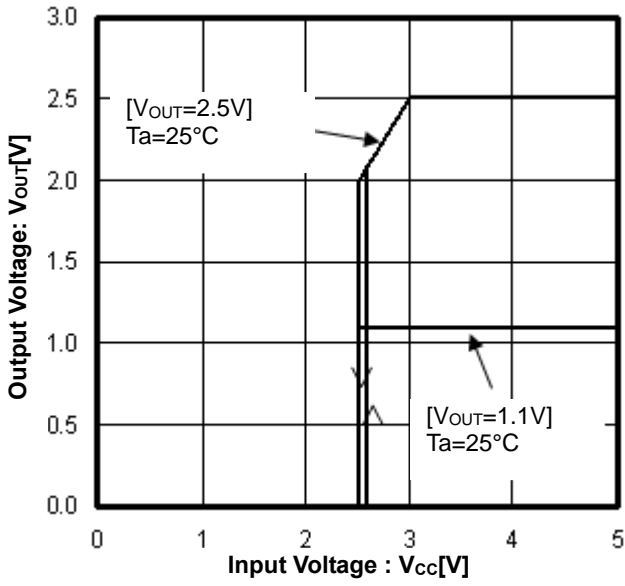

Figure 4. Output Voltage vs Input Voltage

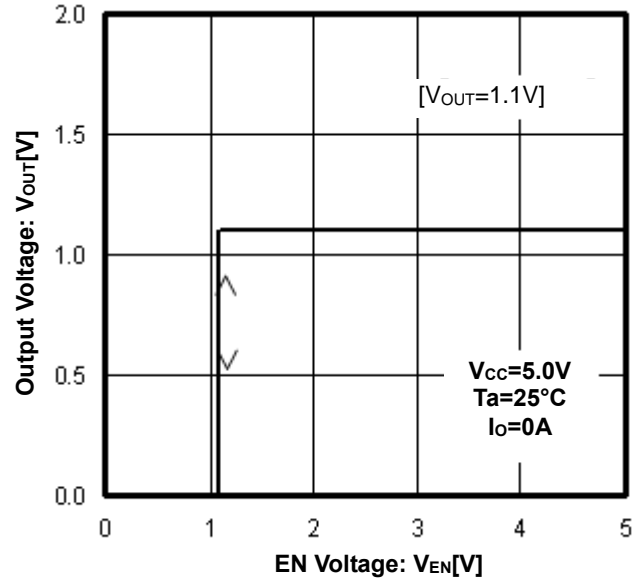

Figure 5. Output Voltage vs EN Voltage

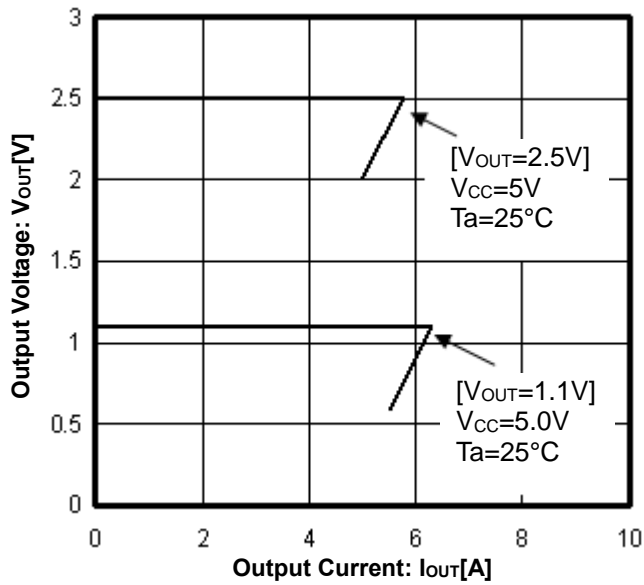

Figure 6. Output Voltage vs Output Current

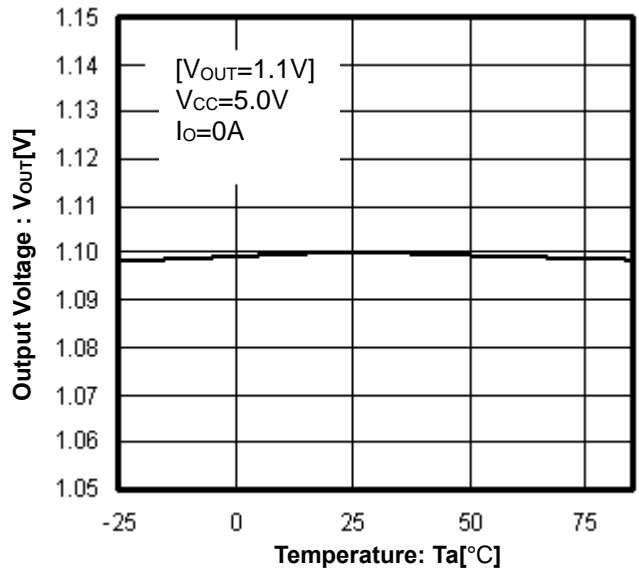

Figure 7. Output Voltage vs Temperature

Typical Performance Curves - continued

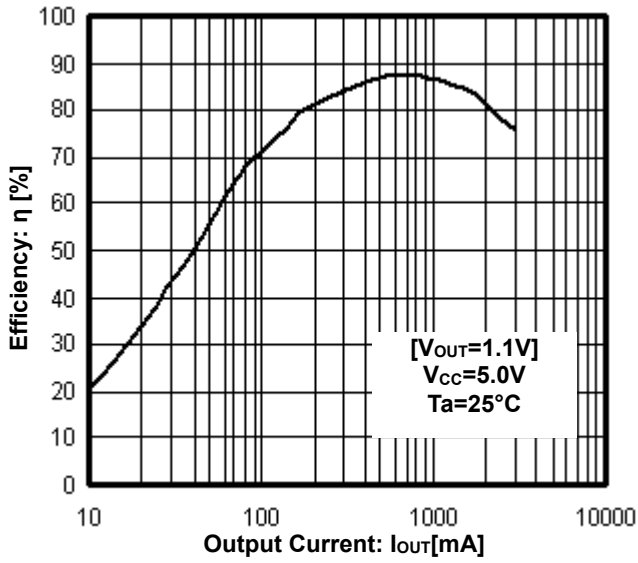

Figure 8. Efficiency vs Output Current

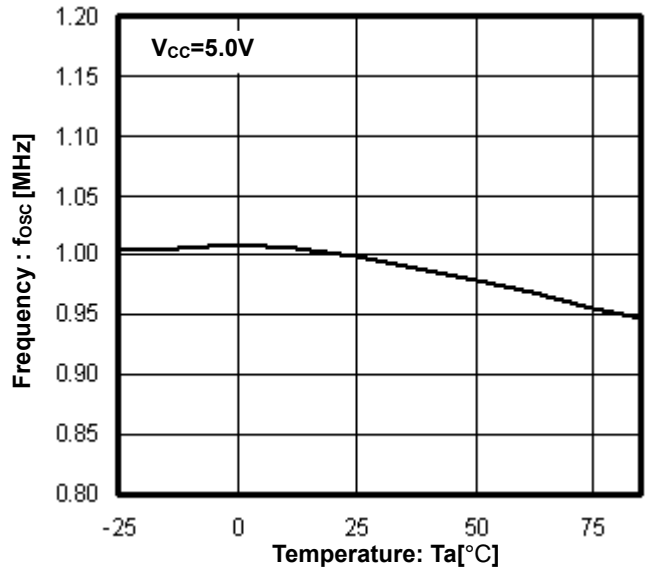

Figure 9. Frequency vs Temperature

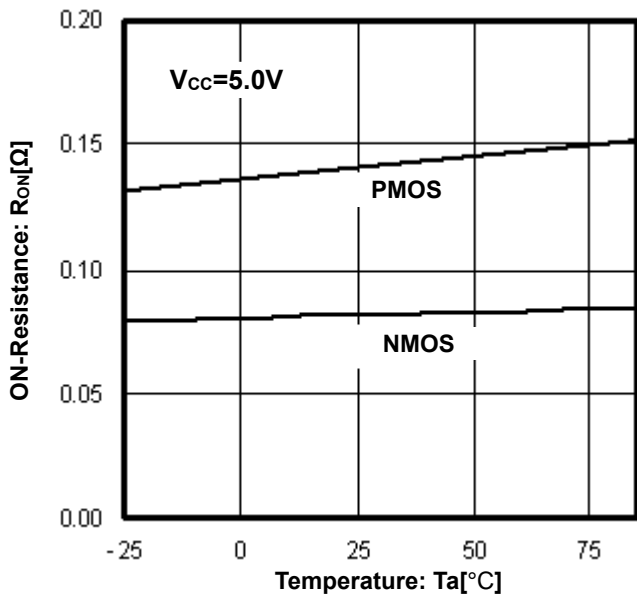

Figure 10. ON-Resistance vs Temperature

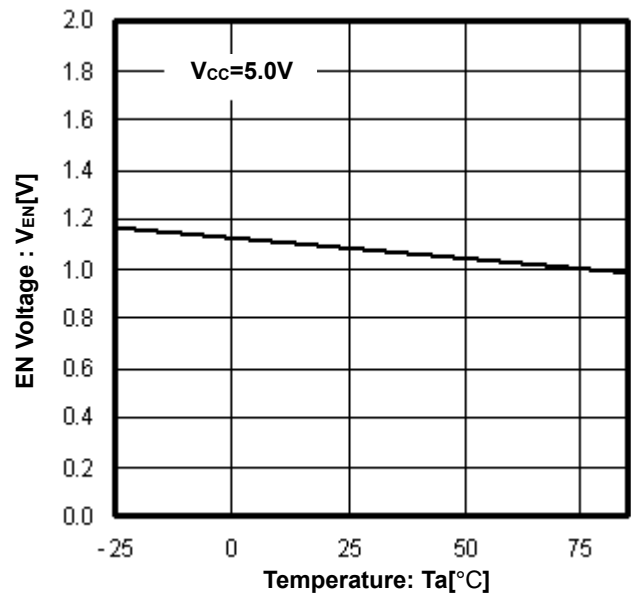

Figure 11. EN Voltage vs Temperature

Typical Performance Curves – continued

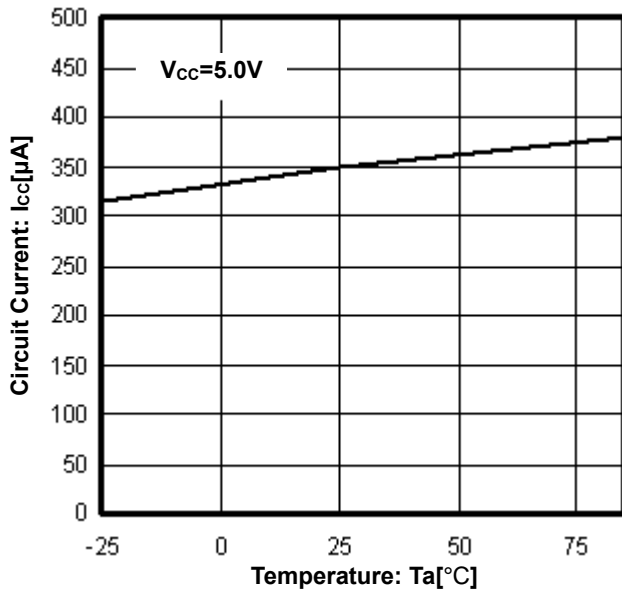

Figure 12. Circuit Current vs Temperature

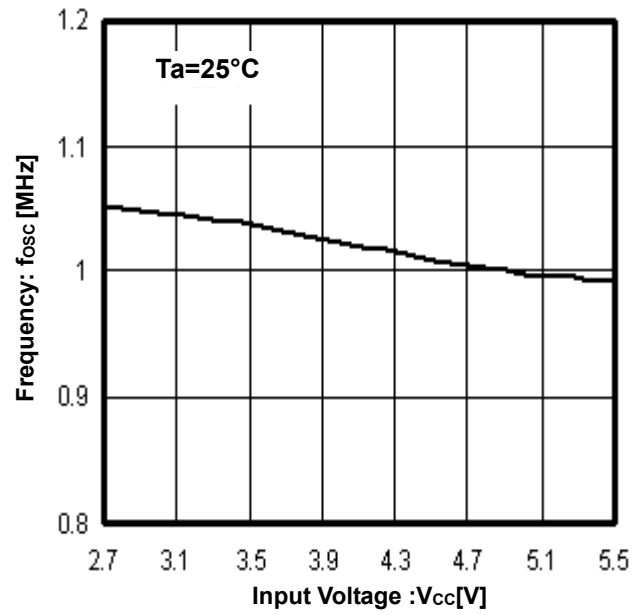

Figure 13. Frequency vs Input Voltage

Typical Waveforms

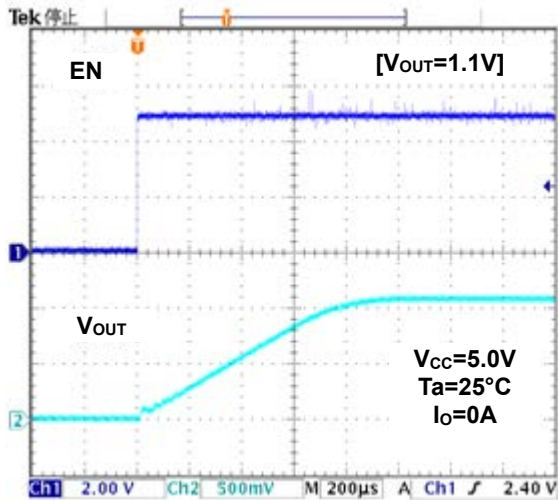

Figure 14. Soft Start Waveform

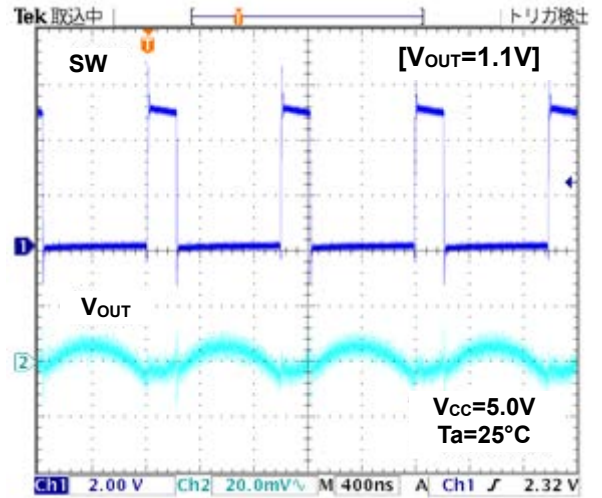

Figure 15. SW Waveform  
( $I_o=10\text{mA}$ )

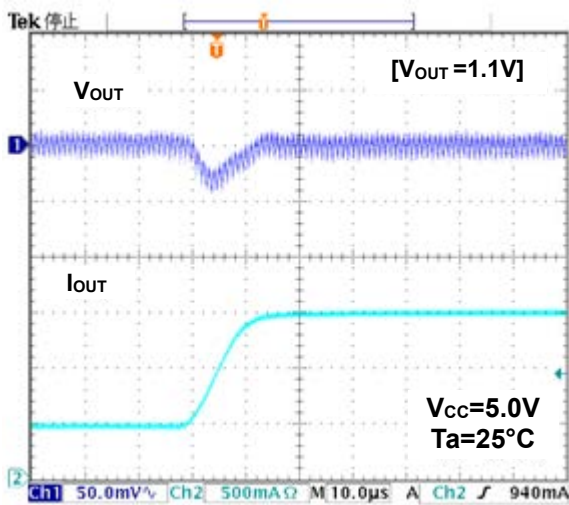

Figure 16. Transient Response  
( $I_o=0.5\text{A}$  to  $1.5\text{A}$ ,  $10\mu\text{s}$ )

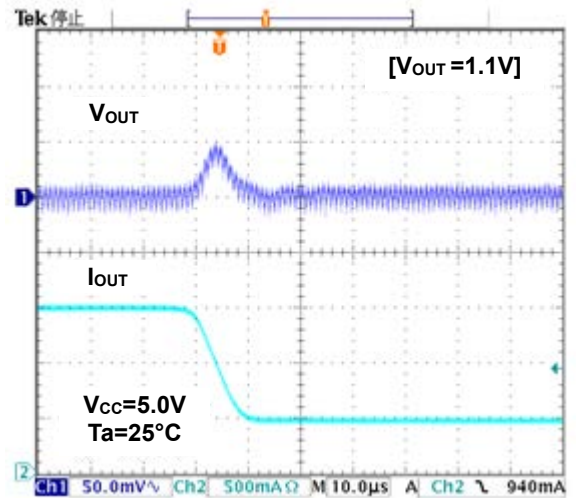

Figure 17. Transient Response  
( $I_o=1.5\text{A}$  to  $0.5\text{A}$ ,  $10\mu\text{s}$ )

Application Information

1. Operation

(1) Synchronous Rectifier  
 Integrated synchronous rectification using two MOSFETs reduces power dissipation and increases efficiency when compared to converters using external diodes. Internal shoot-through current limiting circuit further reduces power dissipation.

(2) Current Mode PWM Control  
 PWM control signal of this IC depends on two feedback loops, the voltage feedback and the inductor current feedback.

(a) PWM (Pulse Width Modulation) Control

The clock signal coming from OSC has a frequency of 1MHz. When OSC sets the RS latch, the P-Channel MOSFET is turned ON and the N-Channel MOSFET is turned OFF. The opposite happens when the current comparator (Current Comp) resets the RS latch i.e. the P-Channel MOSFET is turned OFF and the N-Channel MOSFET is turned ON. Current Comp's output is a comparison of two signals, the current feedback control signal "SENSE" which is a voltage proportional to the current  $I_L$ , and the voltage feedback control signal, FB.

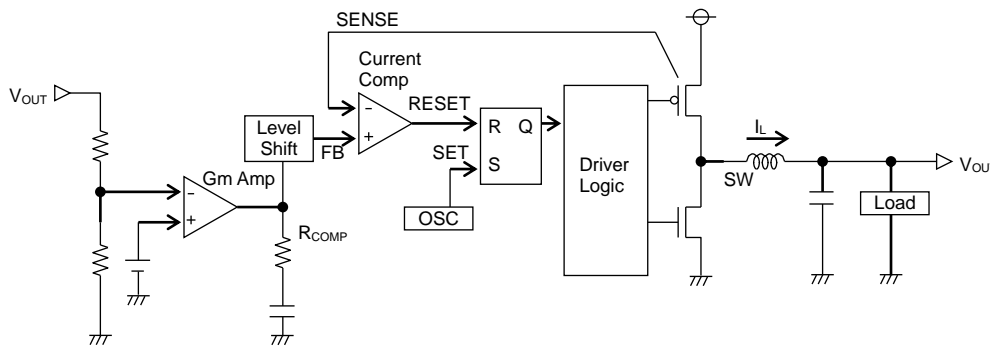

Figure 18. Diagram of Current Mode PWM Control

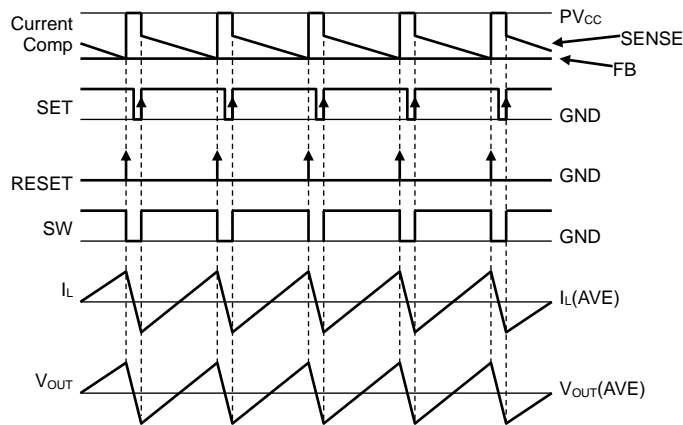

Figure 19. PWM Switching Timing Chart



2. Description of Functions

- (1) Soft-Start Function  
During start-up, the soft-start circuit gradually establishes the output voltage to limit the input current. This prevents the overshoot in the output voltage and inrush current.
- (2) Shutdown Function  
When EN terminal is "Low", the device switches to Standby Mode, and all the functional blocks including reference voltage circuit, internal oscillator and drivers are Turned OFF. Circuit current during standby is 5μA (Typ).
- (3) UVLO Function  
The UVLO circuit detects whether the supplied input voltage is sufficient to obtain the output voltage of this IC. The UVLO threshold has a hysteresis of 50mV (Typ) to prevent the output from chattering.

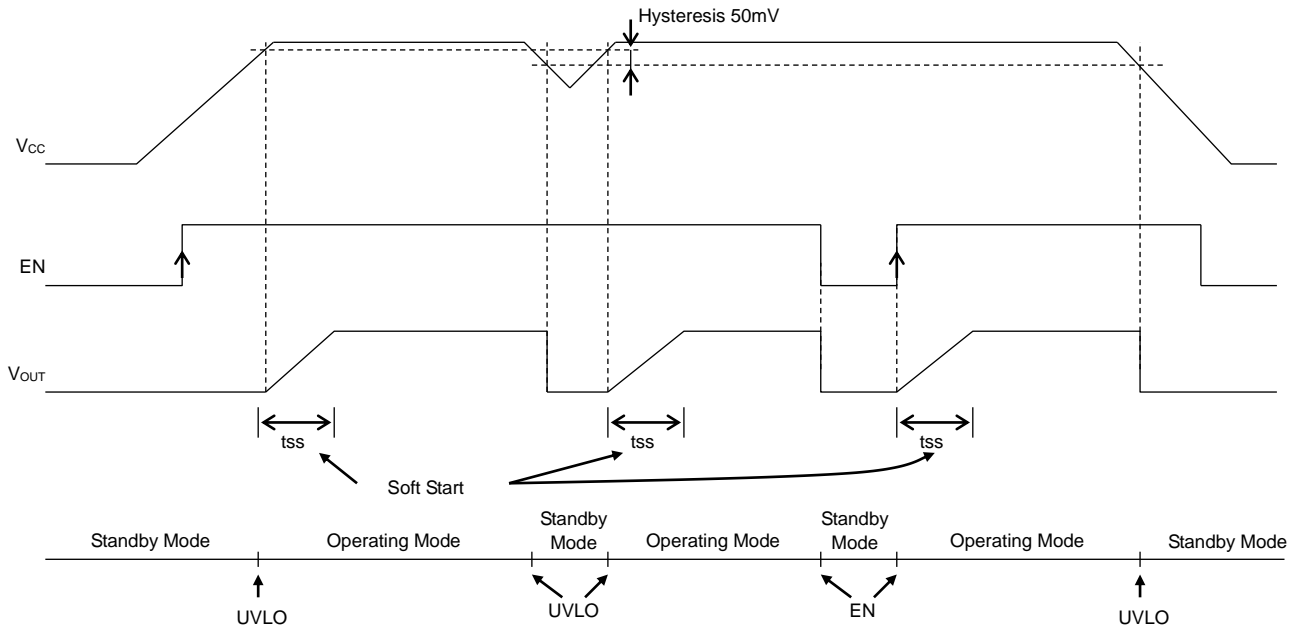

Figure 20. Soft-Start, Shutdown, UVLO Timing Chart

- (4) Short Circuit Current Protection with Time Delay Function  
To protect the IC from breakdown, the short circuit protection turns the output OFF when the internal current limiter is activated continuously for a fixed time ( $t_{LATCH}$ ) or more. The output that is kept OFF may be turned ON again by restarting EN or by resetting UVLO.

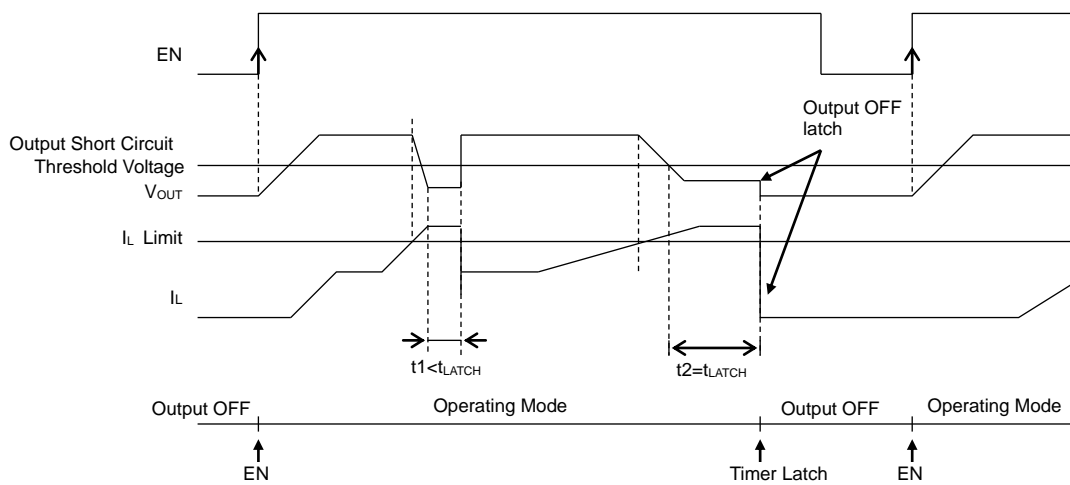
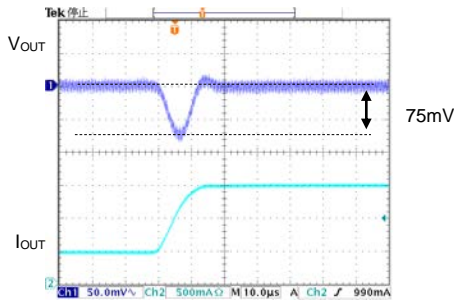

Figure 21. Short Current Protection Circuit with Time Delay Timing Chart

3. Information on Advantages

Advantage 1: Fast Transient Response with Current Mode Control System

Conventional Product (Load response  $I_o = 0.5A$  to  $1.5A$ )



BD8963EFJ (Load Response  $I_o = 0.5A$  to  $1.5A$ )

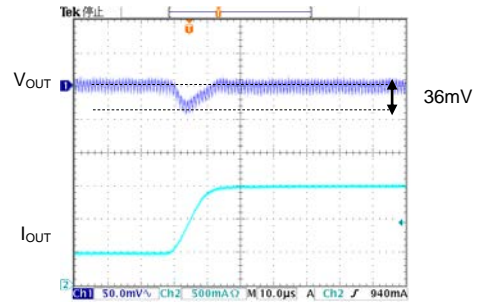

Voltage drop due to sudden change in load was reduced by about 50%.

Figure 22. Comparison of Transient Response

Advantage 2: High Efficiency for all Load Range Because of its Synchronous Rectifier

For heavier load:  
This IC utilizes the synchronous rectifying mode and uses low ON-Resistance MOSFET power transistors.

- { ON-Resistance of P-Channel MOS FET :  $145m\Omega$ (Typ)
- { ON-Resistance of N-Channel MOS FET :  $80m\Omega$ (Typ)

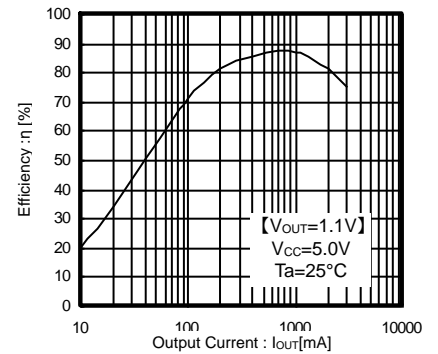

Figure 23. Efficiency

Advantage 3: Smaller Package due to Integration of Small-Sized Power MOSFETs

- Required output capacitor,  $C_o$ , for current mode control:  $10\mu F$  ceramic capacitor
- Required inductance,  $L$ , for the operating frequency of 1 MHz:  $1.5\mu H$  inductor

Reduces the required mounting area

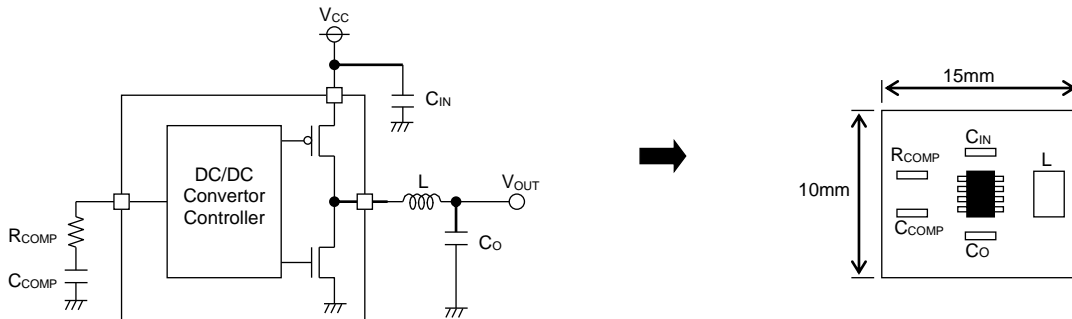

Figure 24. Example Application

#### 4. Switching Regulator Efficiency

Efficiency  $\eta$  may be expressed by the equation shown below:

$$\eta = \frac{V_{OUT} \times I_{OUT}}{V_{IN} \times I_{IN}} \times 100 = \frac{P_{OUT}}{P_{IN}} \times 100 = \frac{P_{OUT}}{P_{OUT} + P_{d\alpha}} \times 100 \quad [\%]$$

Efficiency may be improved by reducing the switching regulator power dissipation factors  $P_{d\alpha}$  as follows:

Dissipation Factors:

- (1) ON-Resistance Dissipation of Inductor and FET :  $P_d(I^2R)$

$$P_d(I^2R) = I_{OUT}^2 \times (R_{COIL} + R_{ON})$$

Where:

$R_{COIL}$  is the DC resistance of inductor

$R_{ON}$  is the ON-Resistance of FET

$I_{OUT}$  is the output current

- (2) Gate Charge/Discharge Dissipation :  $P_d(\text{Gate})$

$$P_d(\text{Gate}) = C_{gs} \times f \times V^2$$

Where:

$C_{gs}$  is the gate capacitance of FET

$f$  is the switching frequency

$V$  is the gate driving voltage of FET

- (3) Switching Dissipation :  $P_d(\text{SW})$

$$P_d(\text{SW}) = \frac{V_{IN}^2 \times C_{RSS} \times I_{OUT} \times f}{I_{DRIVE}}$$

Where:

$C_{RSS}$  is the reverse transfer capacitance of FET

$I_{DRIVE}$  is the peak current of gate

- (4) ESR Dissipation of Capacitor :  $P_d(\text{ESR})$

$$P_d(\text{ESR}) = I_{RMS}^2 \times \text{ESR}$$

Where:

$I_{RMS}$  is the ripple current of capacitor

$\text{ESR}$  is the equivalent series resistance

- (5) Operating Current Dissipation of IC :  $P_d(\text{IC})$

$$P_d(\text{IC}) = V_{IN} \times I_{CC}$$

Where:

$I_{CC}$  is the circuit current

5. Considerations on Permissible Dissipation and Heat Generation

Since this IC functions with high efficiency without significant heat generation in most applications, no special consideration is needed on permissible dissipation or heat generation. In case of extreme conditions, however, including lower input voltage, higher output voltage, heavier load, and/or higher temperature, the permissible dissipation and/or heat generation must be carefully considered.

For dissipation, only conduction losses due to DC resistance of inductor and ON-Resistance of FET are considered. This is because the conduction losses are most significant among other dissipation factors mentioned above including gate charge/discharge dissipation and switching dissipation.

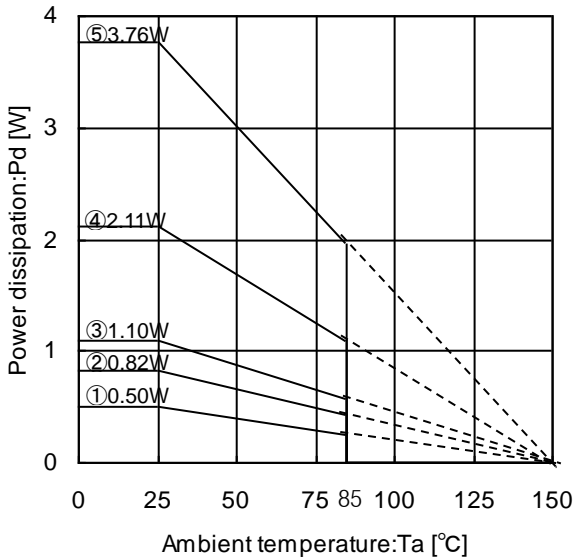

Figure 25. Thermal Derating Curve (HTSOP-J8)

- ① IC only  
θj-a=249.5°C/W
- ② 1 layers (copper foil area:0mm x 0mm)  
θj-a=153.2°C/W
- ③ 2 layers (copper foil area:15mm x 15mm)  
θj-a=113.6°C/W
- ④ 2 layers (copper foil area:70mm x 70mm)  
θj-a=59.2°C/W
- ⑤ 4 layers (copper foil area:70mm x 70mm)  
θj-a=33.3°C/W  
(when mounted on a board 70mm x 70mm x 1.6mm  
Glass-epoxy PCB with thermal Via)

$$P = I_{OUT}^2 \times R_{ON}$$

$$R_{ON} = D \times R_{ONP} + (1 - D)R_{ONN}$$

D is the ON duty (=V<sub>OUT</sub>/V<sub>CC</sub>)

R<sub>COIL</sub> is the DC Resistance of coil

R<sub>ONP</sub> is the ON-Resistance of P-Channel MOS FET

R<sub>ONN</sub> is the ON-Resistance of N-Channel MOS FET

I<sub>OUT</sub> is the Output Current

Ex.) V<sub>CC</sub>=5V, V<sub>OUT</sub>=1.1V, R<sub>ONP</sub>=0.145Ω, R<sub>ONN</sub>=0.08Ω  
 I<sub>OUT</sub>=3A, for example,  
 D=V<sub>OUT</sub>/V<sub>CC</sub>=1.1/5=0.22  
 R<sub>ON</sub>=0.22x0.145+(1-0.22)x0.08  
 =0.0319+0.0624  
 =0.0943[Ω]  
 P=3<sup>2</sup>x0.0943=0.8487[W]

Since R<sub>ONP</sub> is greater than R<sub>ONN</sub> in this IC, the dissipation increases as the on duty becomes greater. Taking into consideration the dissipation shown above, thermal design must be carried out with allowable sufficient margin.

6. Selection of Externally Connected Components

(1) Selection of Inductor (L)

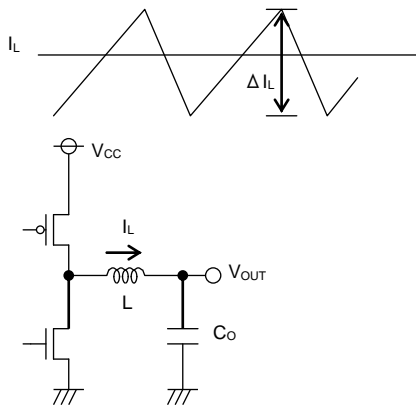

Figure 26. Output Ripple Current

The inductance significantly depends on output ripple current. As shown in equation (1), the ripple current decreases as the inductor and/or switching frequency increases.

$$\Delta I_L = \frac{(V_{CC} - V_{OUT}) \times V_{OUT}}{L \times V_{CC} \times f} \quad [A] \quad \dots (1)$$

Appropriate ripple current at output should be +/-20% of the maximum output current.

$$\Delta I_L = 0.2 \times I_{OUTMax} \quad [A] \quad \dots (2)$$

$$L = \frac{(V_{CC} - V_{OUT}) \times V_{OUT}}{\Delta I_L \times V_{CC} \times f} \quad [H] \quad \dots (3)$$

Where:

$\Delta I_L$  is the Output ripple current, and  $f$  is the Switching frequency

Note: Current exceeding the current rating of the inductor results in magnetic saturation of the inductor, which decreases efficiency. The inductor must be selected to allow a sufficient margin with which the peak current may not exceed its current rating.

If  $V_{CC}=5V$ ,  $V_{OUT}=1.1V$ ,  $f=1MHz$ ,  $\Delta I_L=0.2A \times 3A=0.6A$ , for example, (BD8963EFJ)

$$L = \frac{(5-1.1) \times 1.1}{0.6 \times 5 \times 1M} = 1.43\mu \rightarrow 1.5 \quad [\mu H]$$

Note: Select the inductor with low resistance component (such as DCR and ACR) to minimize dissipation in the inductor for better efficiency.

(2) Selection of Output Capacitor (Co)

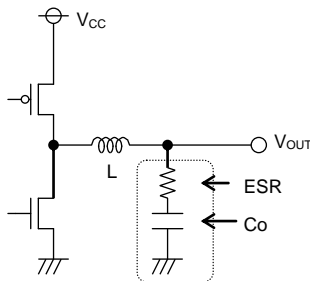

Figure 27. Output Capacitor

Output capacitor should be selected with the consideration on the stability region and the equivalent series resistance required in smoothing the ripple voltage.

Output ripple voltage is determined by equation (4):

$$\Delta V_{OUT} = \Delta I_L \times ESR \quad [V] \quad \dots (4)$$

Where:

$\Delta I_L$  is the Output ripple current, and  $ESR$  is the Equivalent series resistance of output capacitor

Note: Rating of the capacitor should be determined to allow a sufficient margin against output voltage. A 10 $\mu F$  to 100 $\mu F$  ceramic capacitor is recommended. Less ESR allows reduction in output ripple voltage.

(3) Selection of Input Capacitor (CIN)

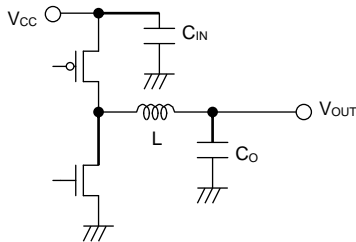

Figure 28. Input Capacitor

Input capacitor to be selected must be a low ESR capacitor with a capacitance sufficient to cope with high ripple current to prevent high transient voltage. The ripple current  $I_{RMS}$  is given by equation (5):

$$I_{RMS} = I_{OUT} \times \frac{\sqrt{V_{OUT}(V_{CC} - V_{OUT})}}{V_{CC}} \quad [A] \quad \dots (5)$$

< Worst case >  $I_{RMSMax}$

When  $V_{CC}$  is twice the  $V_{OUT}$ ,  $I_{RMS} = \frac{I_{OUT}}{2}$

If  $V_{CC}=5V$ ,  $V_{OUT}=1.1V$ , and  $I_{OUTMax}= 3A$ , (BD8963EFJ)

$$I_{RMS} = 3 \times \frac{\sqrt{1.1 \times (5-1.1)}}{5} \approx 1.24 \quad [A_{RMS}]$$

A low ESR 22 $\mu F$ /10V ceramic capacitor is recommended to reduce ESR dissipation of input capacitor for better efficiency.

(4) Calculating  $R_{COMP}$ ,  $C_{COMP}$  for Phase Compensation

Since the Current Mode Control is designed to limit the inductor current, a pole (phase lag) appears in the low frequency area due to CR filter consisting of an output capacitor and a load resistance, while a zero (phase lead) appears in the high frequency area due to the output capacitor and its ESR. Therefore, the phases are easily compensated by adding a zero to the power amplifier output with C and R as described below to cancel a pole at the power amplifier.

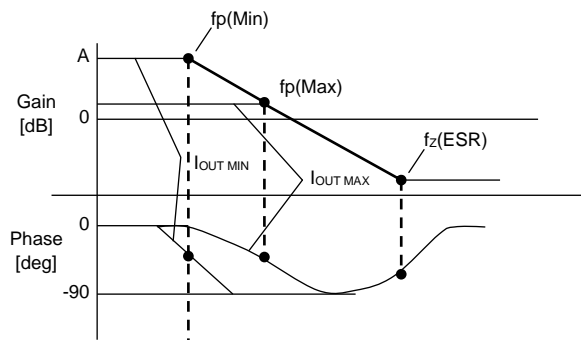

Figure 29. Open Loop Gain Characteristics

$$f_P = \frac{1}{2\pi \times R_O \times C_O}$$

$$f_Z(ESR) = \frac{1}{2\pi \times ESR \times C_O}$$

Pole at Power Amplifier

When the output current decreases, the load resistance  $R_o$  increases and the pole frequency decreases.

$$f_{P(Min)} = \frac{1}{2\pi \times R_{O_{Max}} \times C_O} \quad [Hz] \leftarrow \text{with lighter load}$$

$$f_{P(Max)} = \frac{1}{2\pi \times R_{O_{Min}} \times C_O} \quad [Hz] \leftarrow \text{with heavier load}$$

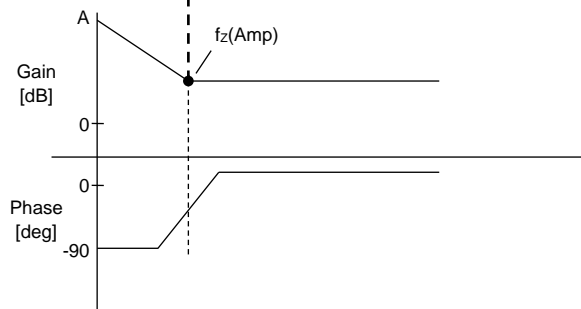

Figure 30. Error Amp Phase Compensation Characteristics

Zero at Power Amplifier

Increasing the capacitance of the output capacitor lowers the pole frequency while the zero frequency does not change. (This is because when the capacitance is doubled, the capacitor ESR is reduced to half.)

$$f_Z(Amp) = \frac{1}{2\pi \times R_{COMP} \times C_{COMP}}$$

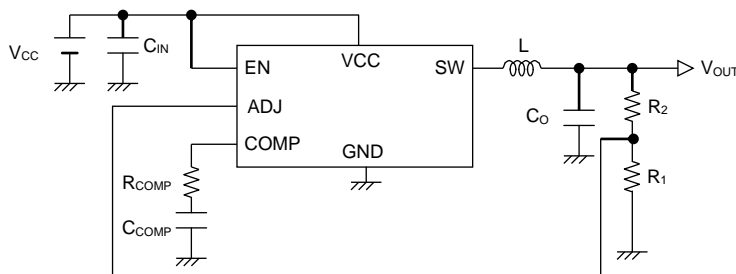

Figure 31. Typical Application

Stable feedback loop may be achieved by canceling the pole  $f_p$  (Min) produced by the output capacitor and the load resistance with CR zero correction by the error amplifier.

$$f_Z(Amp) = f_P(Min)$$

$$\rightarrow \frac{1}{2\pi \times R_{COMP} \times C_{COMP}} = \frac{1}{2\pi \times R_{O_{Max}} \times C_O}$$

(5) Setting the Output Voltage

The output voltage  $V_{OUT}$  is determined by the equation (6):

$$V_{OUT} = (R_2 / R_1 + 1) \times V_{ADJ} \quad \dots (6)$$

Where:

$V_{ADJ}$  is the Voltage at ADJ terminal (0.8V Typ)

The required output voltage may be determined by adjusting  $R_1$  and  $R_2$ .

[ Adjustable output voltage range: 1.0V to 2.5V ]

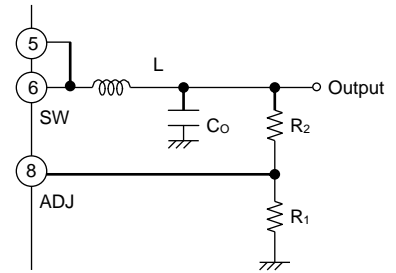

Figure 32. Determination of Output Voltage

Use 1 kΩ to 100 kΩ resistor for  $R_1$ . When using a resistor having a resistance higher than 100 kΩ, check the setup carefully for ripple voltage etc.

The lower limit of input voltage depends on the output voltage. Basically, it is recommended to use the given condition:

$$V_{CCMin} = V_{OUT} + 2.25V$$

Figure 33. shows the necessary output current value at the lower limit of input voltage. (DCR of inductor: 0.05Ω)  
 These data show characteristic value of the IC. It doesn't guarantee the operating range.

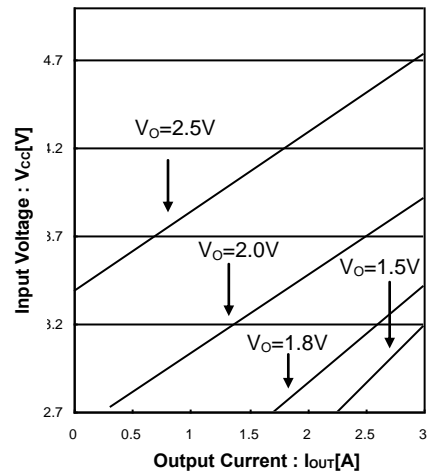

Figure 33. Minimum Input Voltage in each Output Voltage

## 7. BD8963EFJ Cautions on PC Board Layout

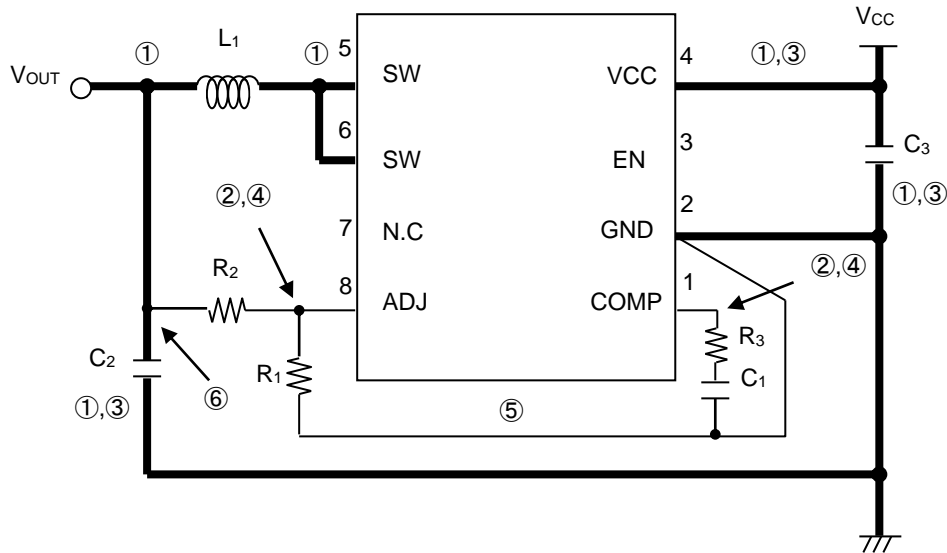

Figure 34. Layout Diagram

- ① To avoid conduction loss, please keep the thick Black lines as short and thick as possible.
- ② Don't place close to the switching current loop.
- ③ As close to IC pin as possible.
- ④ Keep PCB traces as short as possible.
- ⑤ Use a single point ground structure to connect with Pin2.
- ⑥ As close to R2 and C2 as possible.

Note: HTSOP-J8 (BD8963EFJ) has a thermal PAD on the reverse of the package.

The package thermal performance may be enhanced by bonding the PAD to GND plane which occupies a large area of PCB.



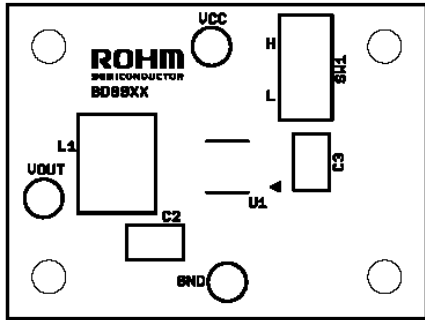

Top Silkscreen Overlay

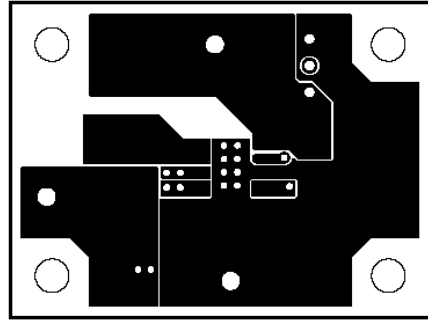

Top Layer

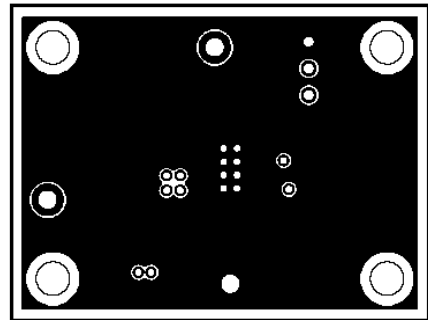

Middle Layer

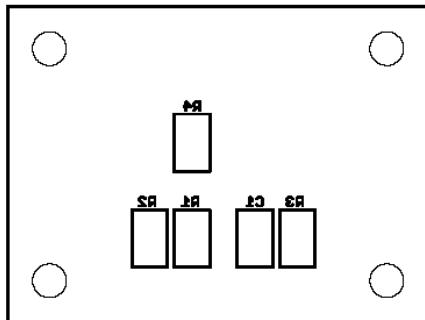

Bottom Silkscreen Overlay

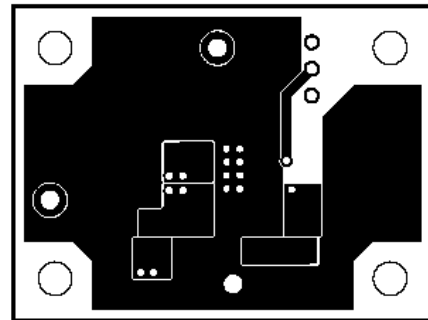

Bottom Layer

Figure 35. Reference PCB Layout Pattern

## 8. Recommended Components List for above Application

Symbol	Part	Value		Manufacturer	Series
L	Coil	1.5 $\mu$ H		TDK	VLC6045T-1R5N
C <sub>IN</sub>	Ceramic Capacitor	V <sub>CC</sub> -V <sub>OUT</sub> >3V	10 $\mu$ F	Kyocera	CM316X5R106M10A
		V <sub>CC</sub> -V <sub>OUT</sub> <3V	22 $\mu$ F	Kyocera	CM32X5R226M10A
C <sub>O</sub>	Ceramic Capacitor	10 $\mu$ F		Kyocera	CM316X5R106M10A
C <sub>COMP</sub>	Ceramic Capacitor	V <sub>OUT</sub> =1.0V	330pF	Murata	GRM18 Series
		V <sub>OUT</sub> =1.1V	330pF	Murata	GRM18 Series
		V <sub>OUT</sub> =1.2V	330pF	Murata	GRM18 Series
		V <sub>OUT</sub> =1.5V	390pF	Murata	GRM18 Series
		V <sub>OUT</sub> =1.8V	390pF	Murata	GRM18 Series
		V <sub>OUT</sub> =2.5V	390pF	Murata	GRM18 Series
R <sub>COMP</sub>	Resistance	V <sub>OUT</sub> =1.0V	2k $\Omega$	Rohm	MCR03 Series
		V <sub>OUT</sub> =1.1V	2k $\Omega$	Rohm	MCR03 Series
		V <sub>OUT</sub> =1.2V	2.4k $\Omega$	Rohm	MCR03 Series
		V <sub>OUT</sub> =1.5V	2.4k $\Omega$	Rohm	MCR03 Series
		V <sub>OUT</sub> =1.8V	3.6k $\Omega$	Rohm	MCR03 Series
		V <sub>OUT</sub> =2.5V	5.6k $\Omega$	Rohm	MCR03 Series

Note: The parts list presented above is an example of recommended parts. Although the parts are standard, actual circuit characteristics should be checked on your application carefully before use. Be sure to allow sufficient margins to accommodate variations between external devices and this IC when employing the depicted circuit with other circuit constants modified. Both static and transient characteristics should be considered in establishing these margins.

I/O Equivalent Circuit

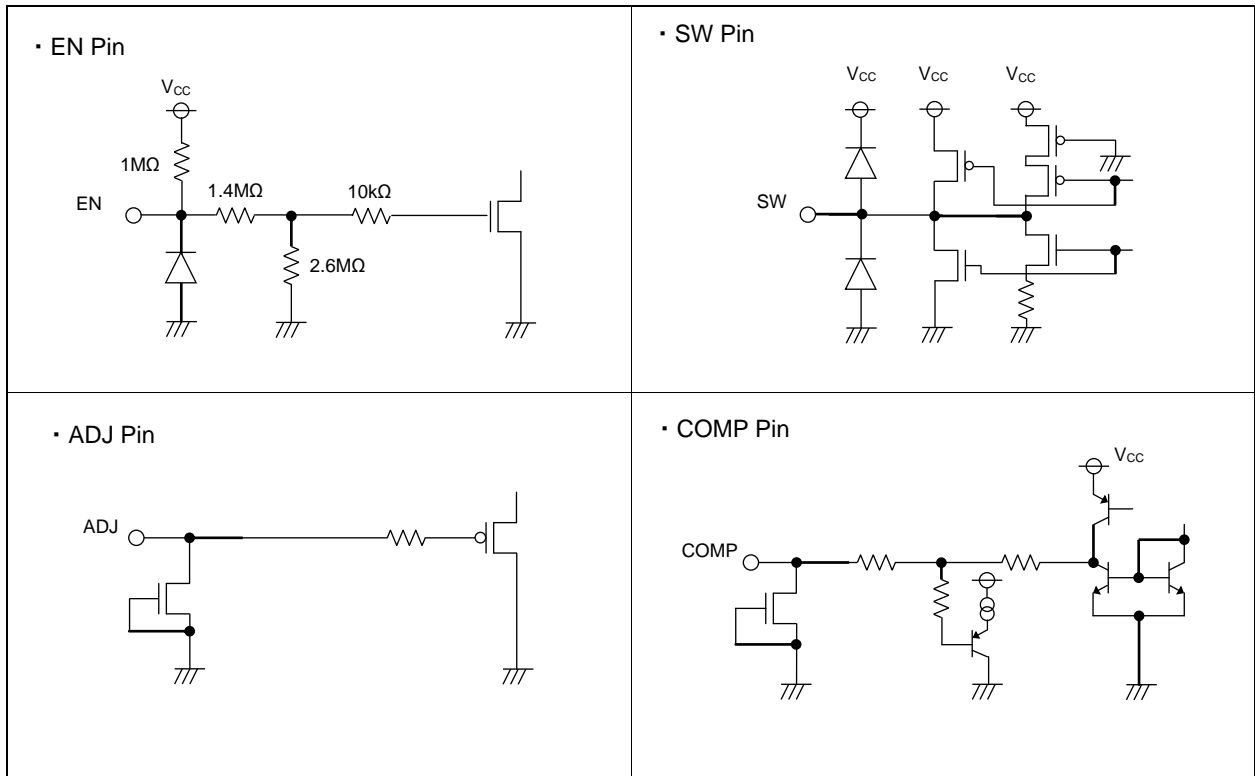

Figure 36. I/O Equivalent Circuit

## Operational Notes

### 1. Reverse Connection of Power Supply

Connecting the power supply in reverse polarity can damage the IC. Take precautions against reverse polarity when connecting the power supply, such as mounting an external diode between the power supply and the IC's power supply pins.

### 2. Power Supply Lines

Design the PCB layout pattern to provide low impedance supply lines. Separate the ground and supply lines of the digital and analog blocks to prevent noise in the ground and supply lines of the digital block from affecting the analog block. Furthermore, connect a capacitor to ground at all power supply pins. Consider the effect of temperature and aging on the capacitance value when using electrolytic capacitors.

### 3. Ground Voltage

Ensure that no pins are at a voltage below that of the ground pin at any time, even during transient condition.

### 4. Ground Wiring Pattern

When using both small-signal and large-current ground traces, the two ground traces should be routed separately but connected to a single ground at the reference point of the application board to avoid fluctuations in the small-signal ground caused by large currents. Also ensure that the ground traces of external components do not cause variations on the ground voltage. The ground lines must be as short and thick as possible to reduce line impedance.

### 5. Thermal Consideration

Should by any chance the power dissipation rating be exceeded the rise in temperature of the chip may result in deterioration of the properties of the chip. In case of exceeding this absolute maximum rating, increase the board size and copper area to prevent exceeding the Pd rating.

### 6. Recommended Operating Conditions

These conditions represent a range within which the expected characteristics of the IC can be approximately obtained. The electrical characteristics are guaranteed under the conditions of each parameter.

### 7. Inrush Current

When power is first supplied to the IC, it is possible that the internal logic may be unstable and inrush current may flow instantaneously due to the internal powering sequence and delays, especially if the IC has more than one power supply. Therefore, give special consideration to power coupling capacitance, power wiring, width of ground wiring, and routing of connections.

### 8. Operation Under Strong Electromagnetic Field

Operating the IC in the presence of a strong electromagnetic field may cause the IC to malfunction.

### 9. Testing on Application Boards

When testing the IC on an application board, connecting a capacitor directly to a low-impedance output pin may subject the IC to stress. Always discharge capacitors completely after each process or step. The IC's power supply should always be turned off completely before connecting or removing it from the test setup during the inspection process. To prevent damage from static discharge, ground the IC during assembly and use similar precautions during transport and storage.

### 10. Inter-pin Short and Mounting Errors

Ensure that the direction and position are correct when mounting the IC on the PCB. Incorrect mounting may result in damaging the IC. Avoid nearby pins being shorted to each other especially to ground, power supply and output pin. Inter-pin shorts could be due to many reasons such as metal particles, water droplets (in very humid environment) and unintentional solder bridge deposited in between pins during assembly to name a few.

## Operational Notes – continued

**11. Unused Input Pins**

Input pins of an IC are often connected to the gate of a MOS transistor. The gate has extremely high impedance and extremely low capacitance. If left unconnected, the electric field from the outside can easily charge it. The small charge acquired in this way is enough to produce a significant effect on the conduction through the transistor and cause unexpected operation of the IC. So unless otherwise specified, unused input pins should be connected to the power supply or ground line.

**12. Regarding the Input Pin of the IC**

This monolithic IC contains P+ isolation and P substrate layers between adjacent elements in order to keep them isolated. P-N junctions are formed at the intersection of the P layers with the N layers of other elements, creating a parasitic diode or transistor. For example (refer to figure below):

When  $GND > Pin A$  and  $GND > Pin B$ , the P-N junction operates as a parasitic diode.

When  $GND > Pin B$ , the P-N junction operates as a parasitic transistor.

Parasitic diodes inevitably occur in the structure of the IC. The operation of parasitic diodes can result in mutual interference among circuits, operational faults, or physical damage. Therefore, conditions that cause these diodes to operate, such as applying a voltage lower than the GND voltage to an input pin (and thus to the P substrate) should be avoided.

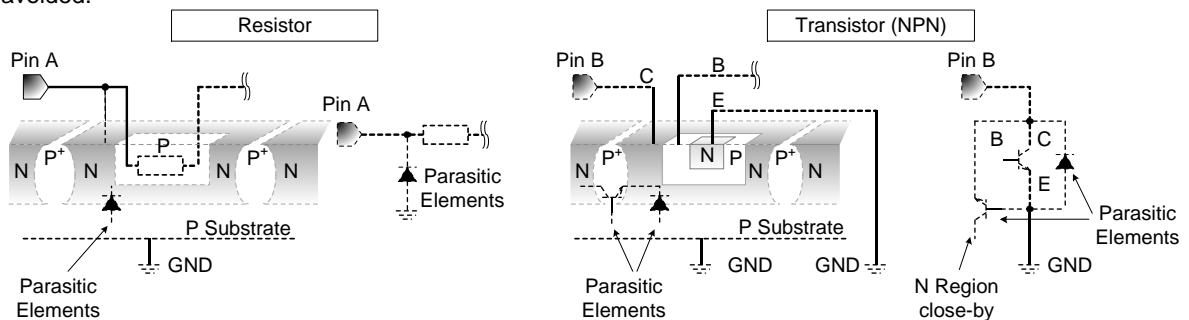

Figure 37. Example of monolithic IC structure

**13. Thermal Shutdown Circuit(TSD)**

This IC has a built-in thermal shutdown circuit that prevents heat damage to the IC. Normal operation should always be within the IC's power dissipation rating. If however the rating is exceeded for a continued period, the junction temperature ( $T_j$ ) will rise which will activate the TSD circuit that will turn OFF all output pins. When the  $T_j$  falls below the TSD threshold, the circuits are automatically restored to normal operation.

Note that the TSD circuit operates in a situation that exceeds the absolute maximum ratings and therefore, under no circumstances, should the TSD circuit be used in a set design or for any purpose other than protecting the IC from heat damage.

**14. Selection of Inductor**

It is recommended to use an inductor with a series resistance element (DCR)  $0.1\Omega$  or less. Especially, note that use of a high DCR inductor will cause an inductor loss, resulting in decreased output voltage. Should this condition continue for a specified period (soft start time + timer latch time), output short circuit protection will be activated and output will be latched OFF. When using an inductor over  $0.1\Omega$ , be careful to ensure adequate margins for variation between external devices and this IC, including transient as well as static characteristics. Furthermore, in any case, it is recommended to start up the output with EN after supply voltage is within.

Ordering Information

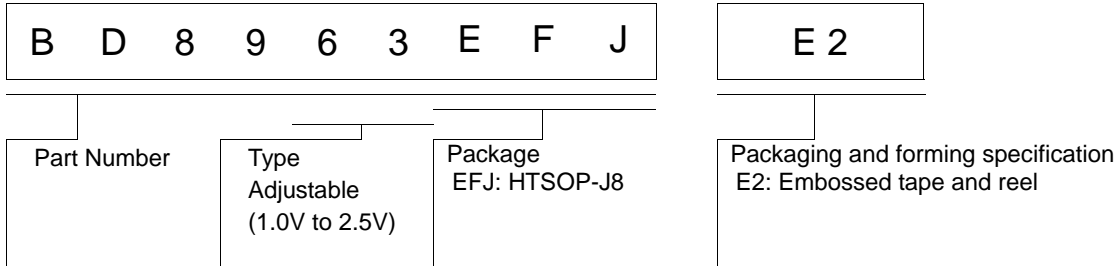

Marking Diagram

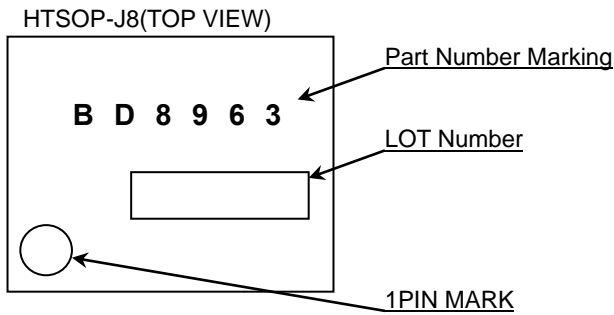

Physical Dimension Tape and Reel Information

Package Name	HTSOP-J8
--------------	----------

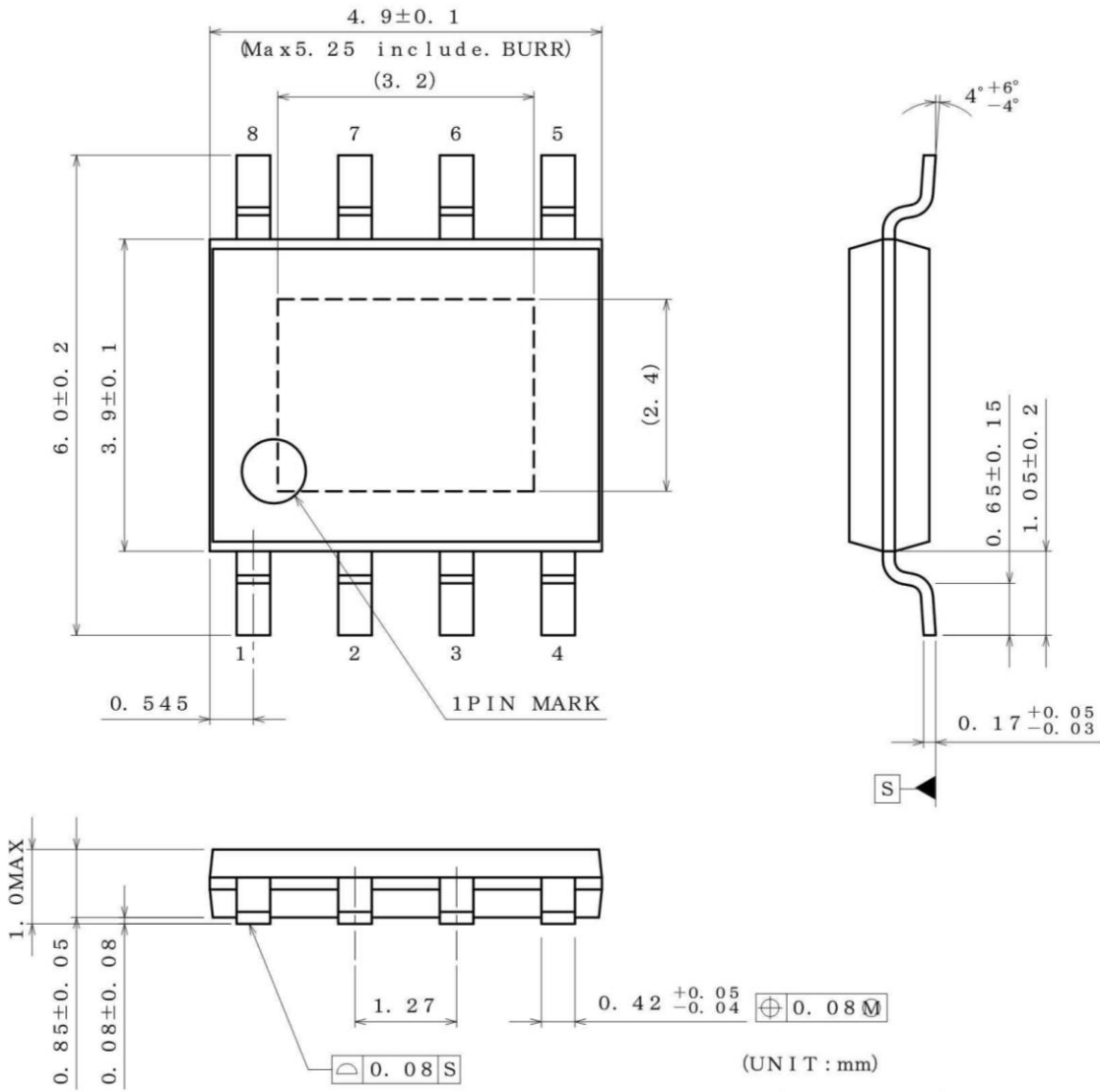

(UNIT : mm)  
 PKG : HTSOP-J8  
 Drawing No. EX169-5002-2

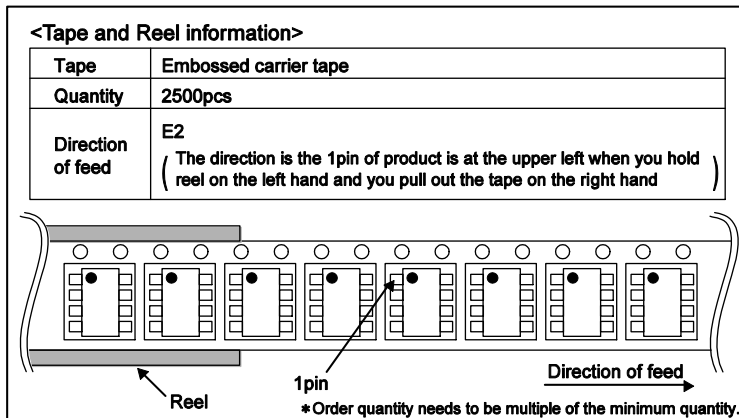

**Revision History**

Date	Revision	Changes
17.Jan.2012	001	New Release
13.May.2014	002	19/24 page I/O Equivalence circuit (EN pin I/O Equivalence Circuit is revised.)
02.Oct.2014	003	Applied the ROHM Standard Style and improved understandability.



# Notice

## Precaution on using ROHM Products

- Our Products are designed and manufactured for application in ordinary electronic equipments (such as AV equipment, OA equipment, telecommunication equipment, home electronic appliances, amusement equipment, etc.). If you intend to use our Products in devices requiring extremely high reliability (such as medical equipment <sup>(Note 1)</sup>, transport equipment, traffic equipment, aircraft/spacecraft, nuclear power controllers, fuel controllers, car equipment including car accessories, safety devices, etc.) and whose malfunction or failure may cause loss of human life, bodily injury or serious damage to property ("Specific Applications"), please consult with the ROHM sales representative in advance. Unless otherwise agreed in writing by ROHM in advance, ROHM shall not be in any way responsible or liable for any damages, expenses or losses incurred by you or third parties arising from the use of any ROHM's Products for Specific Applications.

(Note1) Medical Equipment Classification of the Specific Applications

JAPAN	USA	EU	CHINA
CLASS III	CLASS III	CLASS II b	CLASS III
CLASS IV		CLASS III	

- ROHM designs and manufactures its Products subject to strict quality control system. However, semiconductor products can fail or malfunction at a certain rate. Please be sure to implement, at your own responsibilities, adequate safety measures including but not limited to fail-safe design against the physical injury, damage to any property, which a failure or malfunction of our Products may cause. The following are examples of safety measures:
  - Installation of protection circuits or other protective devices to improve system safety
  - Installation of redundant circuits to reduce the impact of single or multiple circuit failure
- Our Products are designed and manufactured for use under standard conditions and not under any special or extraordinary environments or conditions, as exemplified below. Accordingly, ROHM shall not be in any way responsible or liable for any damages, expenses or losses arising from the use of any ROHM's Products under any special or extraordinary environments or conditions. If you intend to use our Products under any special or extraordinary environments or conditions (as exemplified below), your independent verification and confirmation of product performance, reliability, etc. prior to use, must be necessary:
  - Use of our Products in any types of liquid, including water, oils, chemicals, and organic solvents
  - Use of our Products outdoors or in places where the Products are exposed to direct sunlight or dust
  - Use of our Products in places where the Products are exposed to sea wind or corrosive gases, including Cl<sub>2</sub>, H<sub>2</sub>S, NH<sub>3</sub>, SO<sub>2</sub>, and NO<sub>2</sub>
  - Use of our Products in places where the Products are exposed to static electricity or electromagnetic waves
  - Use of our Products in proximity to heat-producing components, plastic cords, or other flammable items
  - Sealing or coating our Products with resin or other coating materials
  - Use of our Products without cleaning residue of flux (even if you use no-clean type fluxes, cleaning residue of flux is recommended); or Washing our Products by using water or water-soluble cleaning agents for cleaning residue after soldering
  - Use of the Products in places subject to dew condensation
- The Products are not subject to radiation-proof design.
- Please verify and confirm characteristics of the final or mounted products in using the Products.
- In particular, if a transient load (a large amount of load applied in a short period of time, such as pulse. is applied, confirmation of performance characteristics after on-board mounting is strongly recommended. Avoid applying power exceeding normal rated power; exceeding the power rating under steady-state loading condition may negatively affect product performance and reliability.
- De-rate Power Dissipation (Pd) depending on Ambient temperature (Ta). When used in sealed area, confirm the actual ambient temperature.
- Confirm that operation temperature is within the specified range described in the product specification.
- ROHM shall not be in any way responsible or liable for failure induced under deviant condition from what is defined in this document.

## Precaution for Mounting / Circuit board design

- When a highly active halogenous (chlorine, bromine, etc.) flux is used, the residue of flux may negatively affect product performance and reliability.
- In principle, the reflow soldering method must be used on a surface-mount products, the flow soldering method must be used on a through hole mount products. If the flow soldering method is preferred on a surface-mount products, please consult with the ROHM representative in advance.

For details, please refer to ROHM Mounting specification

### Precautions Regarding Application Examples and External Circuits

1. If change is made to the constant of an external circuit, please allow a sufficient margin considering variations of the characteristics of the Products and external components, including transient characteristics, as well as static characteristics.
2. You agree that application notes, reference designs, and associated data and information contained in this document are presented only as guidance for Products use. Therefore, in case you use such information, you are solely responsible for it and you must exercise your own independent verification and judgment in the use of such information contained in this document. ROHM shall not be in any way responsible or liable for any damages, expenses or losses incurred by you or third parties arising from the use of such information.

### Precaution for Electrostatic

This Product is electrostatic sensitive product, which may be damaged due to electrostatic discharge. Please take proper caution in your manufacturing process and storage so that voltage exceeding the Products maximum rating will not be applied to Products. Please take special care under dry condition (e.g. Grounding of human body / equipment / solder iron, isolation from charged objects, setting of Ionizer, friction prevention and temperature / humidity control).

### Precaution for Storage / Transportation

1. Product performance and soldered connections may deteriorate if the Products are stored in the places where:
  - [a] the Products are exposed to sea winds or corrosive gases, including Cl<sub>2</sub>, H<sub>2</sub>S, NH<sub>3</sub>, SO<sub>2</sub>, and NO<sub>2</sub>
  - [b] the temperature or humidity exceeds those recommended by ROHM
  - [c] the Products are exposed to direct sunshine or condensation
  - [d] the Products are exposed to high Electrostatic
2. Even under ROHM recommended storage condition, solderability of products out of recommended storage time period may be degraded. It is strongly recommended to confirm solderability before using Products of which storage time is exceeding the recommended storage time period.
3. Store / transport cartons in the correct direction, which is indicated on a carton with a symbol. Otherwise bent leads may occur due to excessive stress applied when dropping of a carton.
4. Use Products within the specified time after opening a humidity barrier bag. Baking is required before using Products of which storage time is exceeding the recommended storage time period.

### Precaution for Product Label

QR code printed on ROHM Products label is for ROHM's internal use only.

### Precaution for Disposition

When disposing Products please dispose them properly using an authorized industry waste company.

### Precaution for Foreign Exchange and Foreign Trade act

Since our Products might fall under controlled goods prescribed by the applicable foreign exchange and foreign trade act, please consult with ROHM representative in case of export.

### Precaution Regarding Intellectual Property Rights

1. All information and data including but not limited to application example contained in this document is for reference only. ROHM does not warrant that foregoing information or data will not infringe any intellectual property rights or any other rights of any third party regarding such information or data. ROHM shall not be in any way responsible or liable for infringement of any intellectual property rights or other damages arising from use of such information or data.:
2. No license, expressly or implied, is granted hereby under any intellectual property rights or other rights of ROHM or any third parties with respect to the information contained in this document.

### Other Precaution

1. This document may not be reprinted or reproduced, in whole or in part, without prior written consent of ROHM.
2. The Products may not be disassembled, converted, modified, reproduced or otherwise changed without prior written consent of ROHM.
3. In no event shall you use in any way whatsoever the Products and the related technical information contained in the Products or this document for any military purposes, including but not limited to, the development of mass-destruction weapons.
4. The proper names of companies or products described in this document are trademarks or registered trademarks of ROHM, its affiliated companies or third parties.

### General Precaution

1. Before you use our Products, you are requested to carefully read this document and fully understand its contents. ROHM shall not be in any way responsible or liable for failure, malfunction or accident arising from the use of any ROHM's Products against warning, caution or note contained in this document.
2. All information contained in this document is current as of the issuing date and subject to change without any prior notice. Before purchasing or using ROHM's Products, please confirm the latest information with a ROHM sales representative.
3. The information contained in this document is provided on an "as is" basis and ROHM does not warrant that all information contained in this document is accurate and/or error-free. ROHM shall not be in any way responsible or liable for any damages, expenses or losses incurred by you or third parties resulting from inaccuracy or errors of or concerning such information.

## X-ON Electronics

Largest Supplier of Electrical and Electronic Components

*Click to view similar products for [Switching Voltage Regulators](#) category:*

*Click to view products by [ROHM](#) manufacturer:*

Other Similar products are found below :

[FAN53610AUC33X](#) [FAN53611AUC123X](#) [FAN48610BUC33X](#) [FAN48610BUC45X](#) [FAN48617UC50X](#) [R3](#) [430464BB](#) [KE177614](#)  
[MAX809TTR](#) [NCV891234MW50R2G](#) [NCP81103MNTXG](#) [NCP81203PMNTXG](#) [NCP81208MNTXG](#) [NCP81109GMNTXG](#)  
[SCY1751FCCT1G](#) [NCP81109JMNTXG](#) [AP3409ADNTR-G1](#) [NCP81241MNTXG](#) [LTM8064IY](#) [LT8315EFE#TRPBF](#) [LTM4668AIY#PBF](#)  
[NCV1077CSTBT3G](#) [XCL207A123CR-G](#) [MPM54304GMN-0002](#) [MPM54304GMN-0004](#) [MPM54304GMN-0003](#)  
[XDPE132G5CG000XUMA1](#) [MP8757GL-P](#) [MP9943AGQ-P](#) [MIC23356YFT-TR](#) [LD8116CGL](#) [HG2269M/TR](#) [OB2269](#) [XD3526](#) [U6215A](#)  
[U6215B](#) [U6620S](#) [LTC3412IFE](#) [LT1425IS](#) [MAX25203BATJA/VY+](#) [MAX77874CEWM+](#) [XC9236D08CER-G](#) [ISL95338IRTZ](#) [MP3416GJ-P](#)  
[BD9S201NUX-CE2](#) [MP5461GC-Z](#) [MPQ4415AGQB-Z](#) [MPQ4590GS-Z](#) [MAX38640BENT18+T](#) [MAX77511AEWB+](#)