

Large Current External FET Controller Type Switching Regulators

Single-output High-frequency Step-down Switching Regulator(Controller type)

BD9850FVM

Dual-output Step-up, Negative, Step-down Switching Regulator(Controller type)

BD9851EFV



● Description

The BD9850FVM is a 1-channel DC/DC step-down switching regulator controller, while the BD9851EFV is a 2-channel DC/DC step-down switching regulator controller. The BD9850FVM is adaptable for a maximum switching frequency of 2 MHz and the BD9851EFV for that of 3 MHz. Both provide space saving in all applications.

● Features

- 1) Adaptable for 2-MHz switching frequency (externally variable) (BD9850FVM)
Adaptable for 3-MHz switching frequency (externally variable) (BD9851EFV)
- 2) FET direct drive
- 3) High-accuracy reference voltage (Accuracy: $\pm 1\%$)
- 4) Built-in Under Voltage Lock Out circuit (UVLO)
- 5) Built-in Thermal Shutdown circuit (TSD)
- 6) The BD9851EFV provides two channels:
Channel 1 available for selection of step-down/step-up switching
Channel 2 available for selection of step-down/inverting switching.
- 7) Compact MSOP8 package (BD9850FVM) / HTSSOP-B20 package (BD9851EFV)

● Applications

TFT panel, TA/ Router, digital consumer electronics, PC, and portable CD/ DVD/ DVC

● Product lineup

	BD9850FVM	BD9851EFV
Input range	4V to 9V	4V to 18V
Oscillation frequency range	100kHz to 2MHz	10kHz to 3MHz
External synchronization	Not provided	Not provided
Standby function	Not provided	Provided
Operating temperature	-40°C to 85°C	-40°C to 85°C
Package	MSOP8	HTSSOP-B20

● **Absolute maximum ratings** (Ta=25°C)

○ BD9850FVM

Item	Symbol	Rating	Unit
Power supply voltage	Vcc	10	V
Storage temperature	Tstg	-55 to +150	°C
Operating temperature	Topr	-40 to +85	°C
Power dissipation	Pd	587	mW
Maximum junction temperature	Tjmax	+150	°C

Reduce by 4.7 mW/°C over 25°C (When mounted on PCB of 70mm×70mm×1.6mm)

○ BD9851EFV

Item	Symbol	Rating	Unit
Power supply voltage (Between Vcc and GND)	Vcc	20	V
Between VREF and GND	VREF	7	V
Between OUT1 and PVcc1 Between OUT2 and PVcc2	Vouth	20	V
Between OUT1, OUT2 and PGND	Voutl	20	V
Power dissipation	Pd	1000 ^()	mW
Operating temperature	Topr	-40 to +85	°C
Maximum junction temperature	Tjmax	+150	°C
Storage temperature	Tstg	-55 to +150	°C

() Reduce by 8.0 mW/°C over 25°C (When mounted on PCB of 70mm×70mm×1.6mm)

● **Recommended operating range**

○ BD9850FVM

Item	Symbol	Limits			Unit
		min.	Typ.	max.	
Power supply voltage	Vcc	4	7	9	V
Oscillation frequency	fosc	100	-	2000	kHz
Operating temperature	Topr	-40	-	+85	°C

○ BD9851EFV

Item	Symbol	Limits			Unit
		min.	Typ.	max.	
Power supply voltage	Vcc	4	12	18	V
Oscillation frequency	fosc	10	300	3000	kHz
Timing resistor	RRT	3.3	-	47	kΩ
Timing capacitor	CCT	33	-	10000	pF

Electrical characteristics (Unless otherwise specified, Ta=25°C, Vcc=7V, fosc=600kHz)

Item	Symbol	Limits			Unit	Conditions
		min.	Typ.	max.		
[Oscillator block]						
Oscillation frequency	fosc	510	600	690	kHz	RRT = 24kΩ
Frequency regulation	FDV	-5	0	5	%	Vcc = 4V to 9V
Oscillator amplitude voltage	Vpptr	-	0.5	-	V	
[Soft start/SW block]						
CTL/SS pin sink current	ISS	-1.90	-1.00	1.00	μA	VCTL/SS = 1.5V
CTL/SS pin clamp voltage	VSS	2.2	2.4	2.6	V	
CTL threshold voltage	VCTLTH	1.2	1.3	1.4	V	
[PWM comparator block]						
0% threshold voltage	D0	1.5	1.6	1.7	V	fosc = 600kHz
100% threshold voltage	D100	2.0	2.1	2.2	V	fosc = 600kHz
[Error Amp block]						
Threshold voltage	VIN	0.98	1.00	1.02	V	AV = 0dB
Frequency bandwidth	BW	1.5	3.0	-	MHz	
Voltage gain	Av	-	70	-	dB	
Input bias current	IIB	-150	-70	-	A	
Maximum output voltage	VCH	2.3	2.4	2.6	V	
Minimum output voltage	VCL	-	0.03	0.20	V	
Output source current	IOI	-3.1	-1.6	-1.0	mA	VFB = 1.0V
Output sink current	IOO	12	50	125	mA	VFB = 1.0V
[VREF block]						
VREF output voltage	VREF	2.475	2.500	2.525	V	IVREF = 0mA
FREF load regulation	ΔVREFIO	-	-	10	mV	IVREF = 0mA to -1mA
VREF current capacitance	IVREF	-45	-16	-1	mA	
[Total device]						
Standby current	ICCS	420	610	960	μA	
Average supply current	ICCA	3.4	5.0	7.8	mA	At no load
[Output block]						
ON resistance	RON	0.9	2.5	8.0	Ω	
Output transient time	Tr/Tf	-	20	-	nsec	Cout = 1000pF
[Under voltage lockout block]						
Threshold voltage	VUT	3.7	3.8	3.9	V	Vcc sweep down
Hysteresis width	VUThy	0.05	0.10	0.15	V	

Design guarantee

Not designed to be radiation-resistant.

Electrical characteristics (Unless otherwise specified, Ta=25°C, Vcc=12V, fosc=300kHz, STB=3V)

Item	Symbol	Limits			Unit	Conditions
		min.	Typ.	max.		
[Total device]						
Standby mode circuit current	Iccst	–	–	5	μA	STB=0V
Operation mode circuit current	Icc	1.5	2.5	4.1	mA	FB1, FB2=0V
[Reference voltage block]						
Output voltage	VREF	2.475	2.500	2.525	V	Io=–0.1mA
Input stability	DVli	–	–	10	mV	Vcc=4Vto18V, Io=–0.1mA
Load stability	DVlo	–	–	10	mV	Io=–0.1mA to –1mA
Short circuit mode output current	Ios	–45	–12	–3	mA	
[Oscillator block]						
Oscillation frequency	fosc	270	300	330	kHz	RRT=24kΩ, CCT=220pF
Oscillation frequency regulation	Dfosc	–2	0	2	%	Vcc=4Vto18V
[Error Amp block]						
Threshold voltage	Vthea	0.98	1.00	1.02	V	Ch1
Input offset voltage	Vofst	–10	0	10	mV	Ch2
Common-mode input voltage range	Vcm	0.3	–	2.0	V	Ch2
Input bias current	Ibias	–150	–70	–	nA	
Voltage gain	Av	60	75	90	dB	DC Design guarantee
Frequency bandwidth	Bw	3	6	13	MHz	MHz Design guarantee
Maximum output voltage	Vfbh	VREF–0.1	–	VREF	V	
Minimum output voltage	Vfbl	–	–	0.1	V	
Output sink current	Isink	1.6	6	16	mA	FB pin
Output source current	Isource	–260	–160	–90	μA	FB pin
[PWM comparator block]						
0% threshold voltage	Vth0	1.21	1.31	1.41	V	FB voltage
100% threshold voltage	Vth100	1.74	1.84	1.94	V	FB voltage
DTC bias current	Idtc	–1	–	1	μA	
[FET driver block]						
ON resistance	RONN	1.5	3	3	Ω	When OUT=Lo
	RONP	1	2	2	Ω	When OUT=Hi
SEL1 input voltage range	Vselh	Vcc–0.2	–	–	V	In step-down switching
	Vsell	0	–	–	V	In step-down switching
[Control block]						
Threshold voltage	Vstb	0.6	1.5	1.5	V	
Sink current	Istb	6	15	15	μA	STB=3V
[Short circuit protection circuit (SCP) block]						
Timer start voltage	Vtime	2.2	2.3	2.3	V	FB voltage
Threshold voltage	Vthscp	1.4	1.5	1.5	V	SCP voltage
Standby mode voltage	Vstscp	–	10	10	mV	SCP voltage
Source current	Vsoscsp	–3.2	–2.0	–2.0	μA	SCP=0.75V
[Under voltage lockout block (UVLO)]						
Threshold voltage	Vuvlo	3.58	3.7	3.7	V	Vcc sweep down
Hysteresis width	DVuvlo	0.05	0.11	0.11	V	

Design guarantee

● **Characteristic data**
(BD9850FVM)

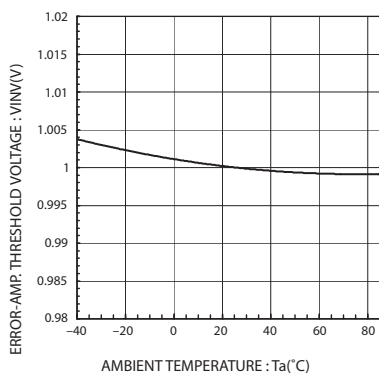

Fig.1 Error Amp threshold voltage vs. Ambient temperature

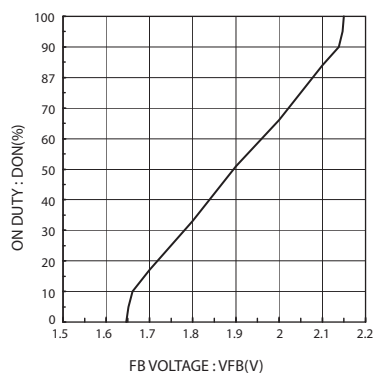

Fig.2 FB voltage vs. ON Duty

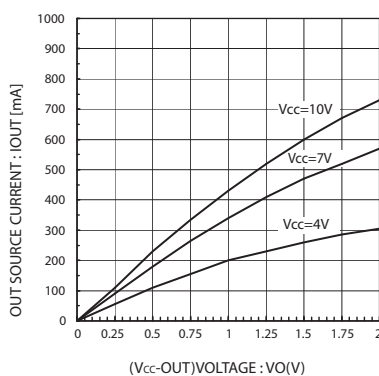

Fig.3 (Vcc-OUT) Voltage vs. Output source current

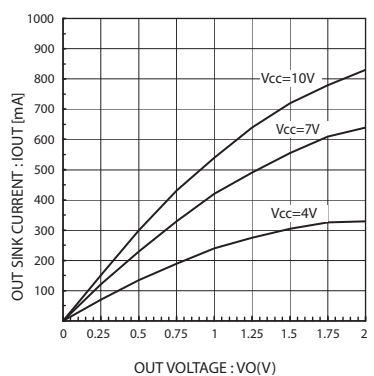

Fig.4 Output voltage vs. Output sink current

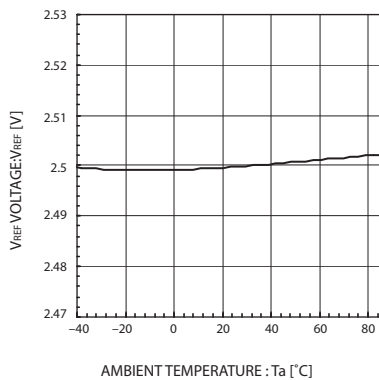

Fig.5 VREF vs. Ambient temperature

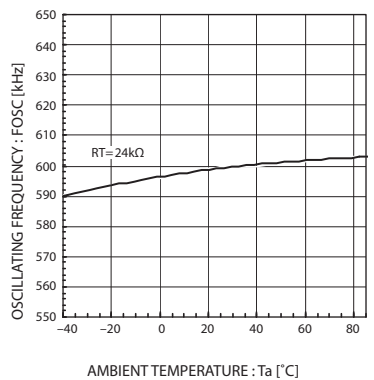

Fig.6 Oscillation frequency vs. Ambient temperature

(BD9851EFV)

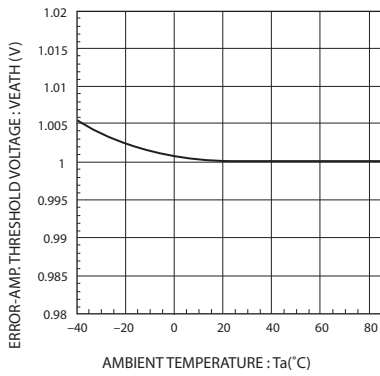

Fig.7 Error Amp threshold voltage vs. Ambient temperature

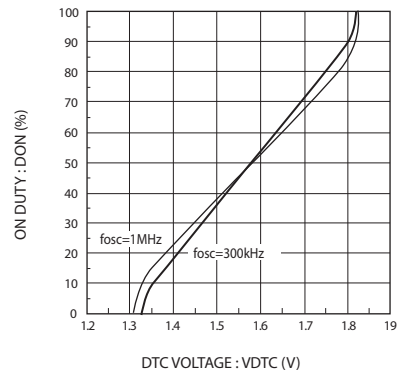

Fig.8 FB voltage vs. ON Duty

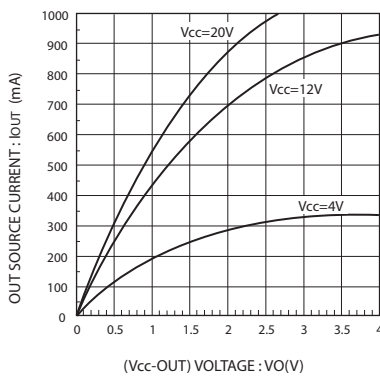

Fig.9 (Vcc-OUT) Voltage vs. Output source current

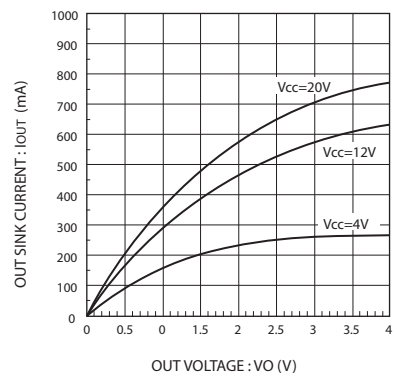

Fig.10 Output voltage vs. Output sink current

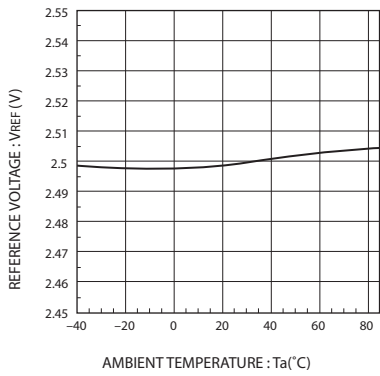

Fig.11 VREF vs. Ambient temperature

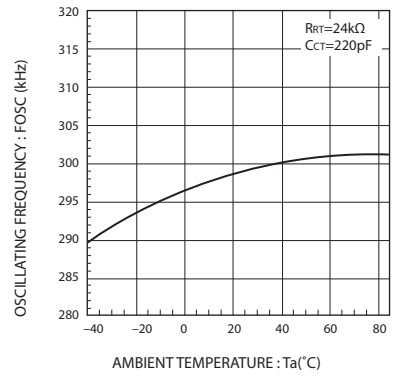

Fig.12 Oscillation frequency vs. Ambient temperature

● Block diagram / Pin assignment

(BD9850FVM)

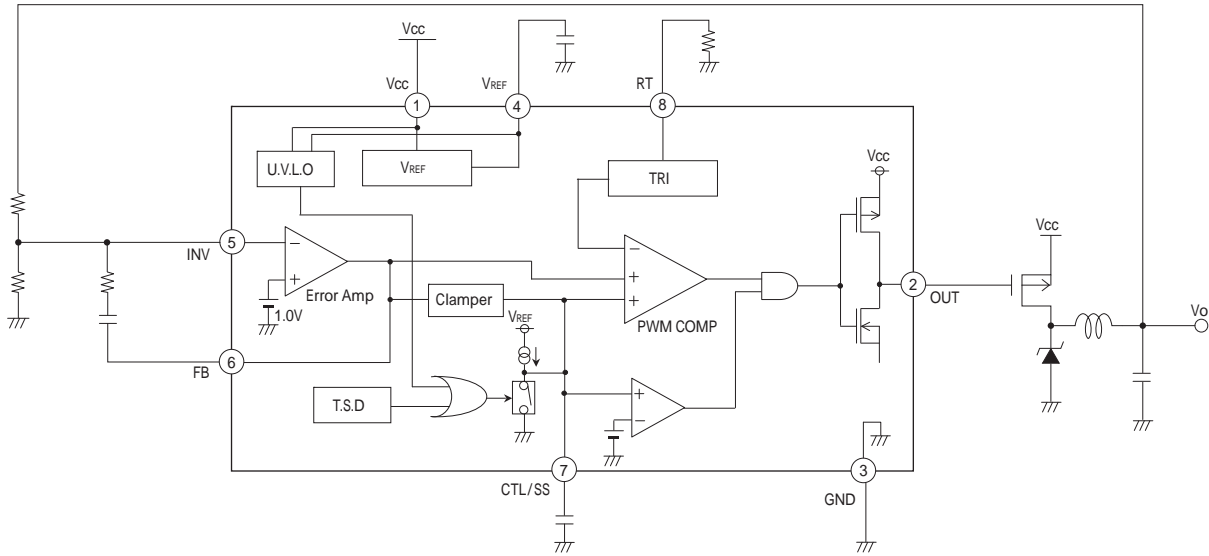
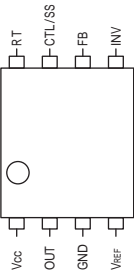

Fig.13 BD9850FVM Block diagram



Pin No.	Pin name	Function
1	Vcc	Power supply
2	OUT	FET driver drive output
3	GND	Ground
4	VREF	Reference voltage (2.5V±1%) output
5	INV	Error Amp inverting input
6	FB	Error Amp output
7	CTL/SS	Control/Soft start common
8	RT	Oscillation frequency setting resistor connection

(BD9851EFV)

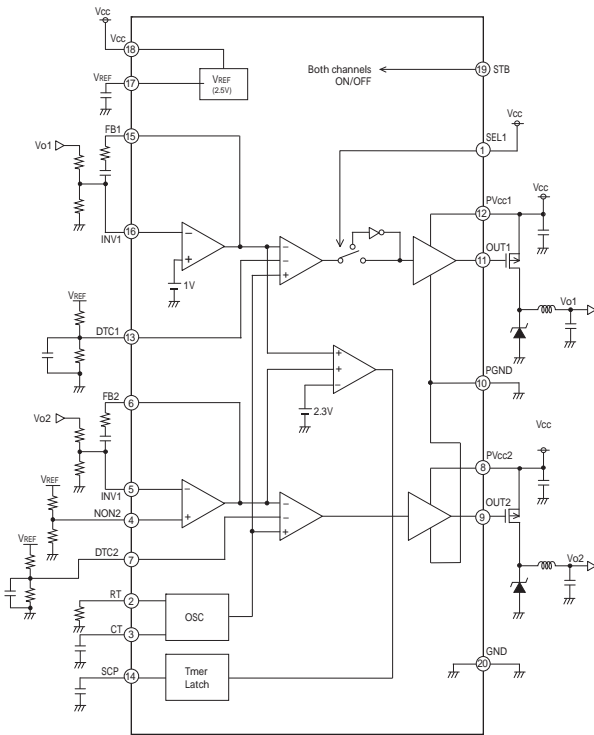
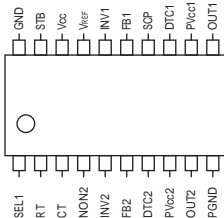

Fig.14 BD9851EFV Block diagram



Pin No.	Pin name	Function
1	SEL1	CH1 drive FET setting (Vcc short: P-ch drive, GND short: N-ch drive)
2	RT	Oscillation frequency setting resistor connection
3	CT	Oscillation frequency setting capacitor connection
4	NON2	Error Amp non-inverting input (CH2)
5	INV2	Error Amp inverting input (CH2)
6	FB2	Error Amp output (CH2)
7	DTC2	Maximum duty/soft start setting (CH2)
8	PVcc2	FET driver block power supply input (CH2)
9	OUT2	FET driver block output (CH2)
10	PGND	FET driver block ground
11	OUT1	FET driver block output (CH1)
12	PVcc1	FET driver block power supply input (CH1)
13	DTC1	Maximum duty/soft start setting (CH1)
14	SCP	Short circuit protection timer setting capacitor connection
15	FB1	Error Amp output (CH1)
16	INV1	Error Amp inverting input (CH1)
17	VREF	Reference voltage (2.5V±1%) output
18	Vcc	Power supply input
19	STB	ON/OFF control
20	GND	Ground
-	FIN on reverse	Make FIN on the reverse open or ground to GND (pin 20) (However, open FIN on the reverse will degrade radiation performance.)

● Description of operations

1) Reference voltage block

The reference voltage block generates a constant voltage with temperature compensated through inputting the power supplied from the Vcc pin. The output voltage is 2.5 V, with a $\pm 1\%$ accuracy. To cancel noises, insert a capacitor with a low ESR (several tens of m Ω) between the VREF and GND pins. It is recommended to use a ceramic capacitor of 1 μ F for this purpose.

2) Triangular wave oscillator block

By connecting the resistor and capacitor of frequency settings to the RT and CT pins (only to RT pin on the BD9850FVM), a triangular wave will be generated and then input to the PWM comparators of Channels 1 and 2.

3) Error Amp block

The Error Amp block detects the output voltage of the INV pin, amplifies an error with the set output voltage, and then outputs the error from the FB pin. The comparison voltage is 1 V, with a $\pm 2\%$ accuracy. (The Channel 2 of the BD9851EFV uses the NON pin input voltage as a reference.)

Inserting a resistor and capacitor between the INV and FB pins will conduct phase compensation.

4) PWM comparator block

The PWM comparator block converts the output voltage (FB voltage) into a PWM waveform and outputs it to the FET driver.

<Dead time control> (Only available on the BD9851EFV)

Inputting a voltage, divided by resistance of the VREF pin in the DTC pin, will allow maximum ON duty setting.

<Soft start (BD9850FVM)>

Inserting a capacitor between the CTL/SS and GND pins will allow the soft start function to control the rising output voltage.

<Soft start (BD9851EFV)>

Inserting a capacitor between the DTC and GND pins will allow the soft start function to control the rising output voltage.

Furthermore, the overshoot of output voltage at startup can be derated. Adding a Schottky diode between the FB and DTC pins will make it possible to suppress the overshoot rate (only available with step-down application).

5) FET driver block

This block is a push-pull type driver enabling direct drive of external MOS FET.

<Setting of step-down/step-up switching (Only available for Channel 1 of BD9851EFV)>

For the Channel 1, SEL1 pin setting will determine the application function.

Set the SEL1 pin to step-down (P-ch drive) mode for short-circuiting Vcc or to step-up (N-ch drive) mode for short-circuiting GND.

Furthermore, be sure to short-circuit the SEL1 pin to Vcc or GND pin.

6) Standby function

(BD9850FVM)

The CTL/SS pin allows for output ON/OFF control. Set the CTL/SS pin voltage to "H" to activate the output ON control.

(BD9851EFV)

The STB pin allows for output ON/OFF control. Set the STB pin voltage to "H" to activate the output ON control.

The standby mode circuit current should be set to less than 5 μ A.

7) Short circuit protection circuit (SCP) (Only available on BD9851EFV)

The SCP is a timer-latch type short circuit protection circuit.

If the output voltage of either channel drops below the set voltage, the Error Amp will be activated to increase the FB voltage and initiate charging the capacitor connected to the SCP pin with a 2 μ A current. When the SCP pin voltage exceeds 1.5 V, the latch circuit will be activated to fix the output of both channels at OFF and, at the same time, the DTC pin at "L" level.

In order to rest the latch circuit, set the STB pin to "L" level once, and then to "H" level. Or, turn ON the power supply again.

Furthermore, if the short circuit protection circuit is not used, short-circuit the SCP pin to the GND pin.

8) Under Voltage Lock Out (UVLO) circuit

The UVLO is a protection circuit to prevent the IC from malfunctioning when the power supply turns ON or if an instantaneous power interruption occurs.

When the Vcc voltage falls below 3.8 V (or 3.7 V on the BD9851EFV), the output of both channels will be fixed at "OFF" and, at the same time, the DTC pin at "L" level. Hysteresis width of 0.1 V (or 0.11 V on the BD9851EFV) is provided for the detection voltage and release voltage of the UVLO in order to prevent malfunctions of the IC which may result from variations in the input voltage due to threshold online.

Furthermore, if the latch circuit is activated through the short circuit protection circuit, the circuit will be reset by this UVLO.

9) Thermal shutdown circuit (TSD)

The TSD is a protection circuit to prevent the destruction of the IC due to abnormal heat generation.

If the TSD detects an abnormal heat generation (175°C) on the chip, the output of both channels will be fixed at "OFF" and, at the same time, the DTC pin at "L" level. Hysteresis width (15°C) is provided for the superheat detection and release temperatures in order to prevent malfunctions of the IC which may result from variations in the input voltage due to threshold online.

Furthermore, if the latch circuit is activated through the short circuit protection circuit, the circuit will be reset by this TSD.

● Timing chart

• In startup/normal operation
(BD9850FVM)

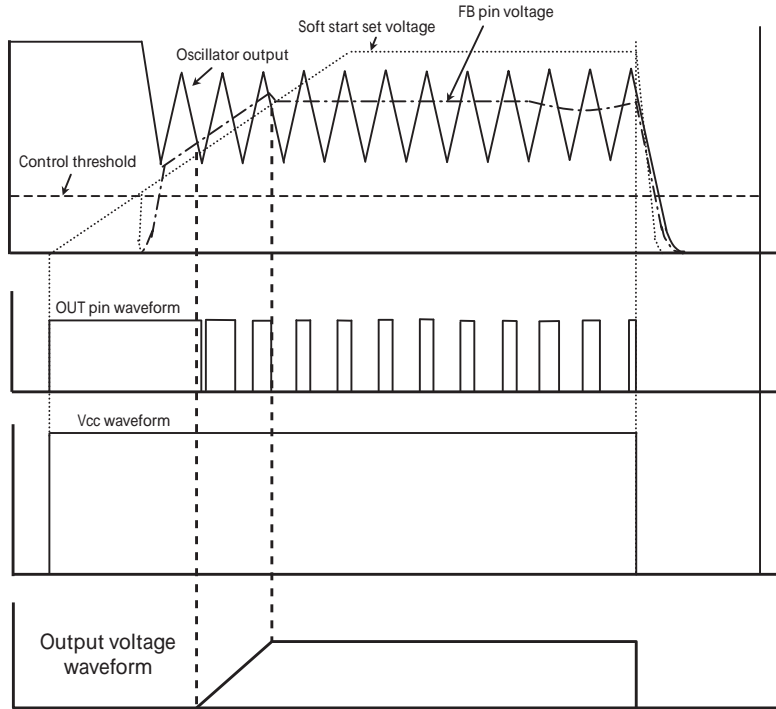

Fig.15 BD9850FVM Timing chart

(BD9851EFV)

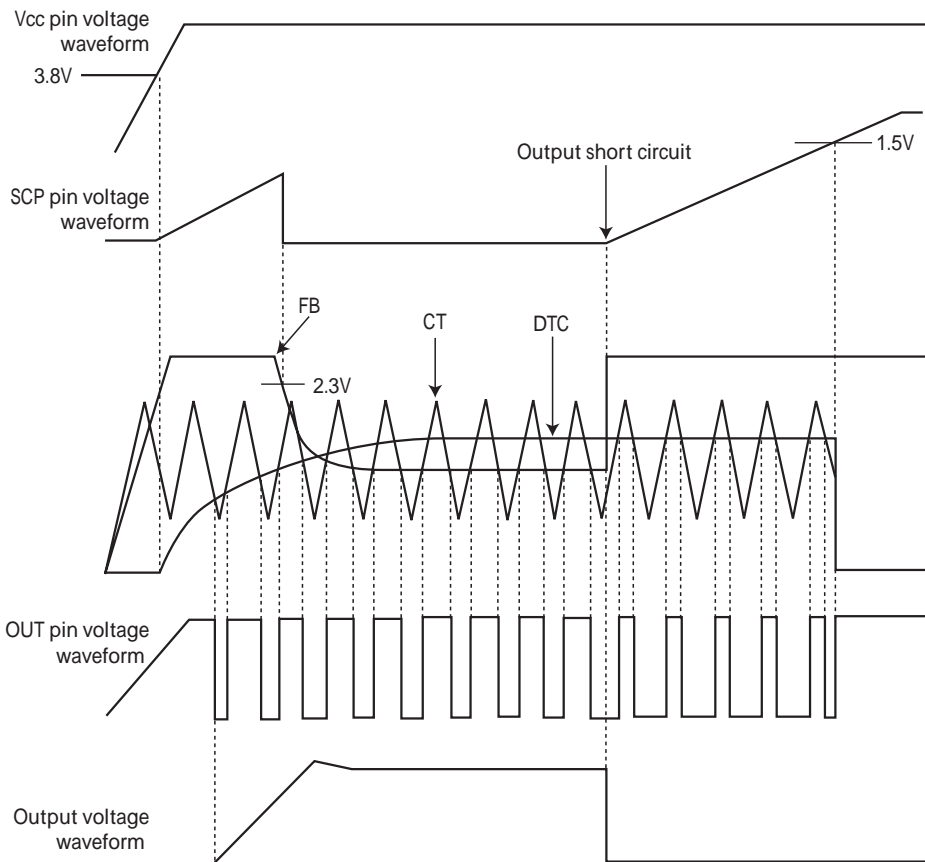

Fig.16 BD9851EFV Timing chart

● **Description of external components**

- Setting of output voltage (BD9850FVM)

Setting of output voltage for the step-down application can be calculated by the formula below :

Setting procedure	Application
$V_o = V_{thea} \times (R_1 + R_2) / R_2 \text{ [V]}$ (V _{thea} : Error Amp threshold voltage Typ. 1.0 [V])	

● **Setting of output voltage (BD9851EFV)**

Setting procedure	Application
<ul style="list-style-type: none"> • Step-down (CH1), Step-up (CH1) $V_{o1} = V_{thea} \times (R_1 + R_2) / R_2 \text{ [V]}$ (V _{thea} : Error Amp threshold voltage Typ. 1.0 [V])	
<ul style="list-style-type: none"> • Step-down (CH2) $V_{o2} = V_{NON2} \times (R_1 + R_2) / R_2 \text{ [V]}$ $V_{NON2} = 2.5 \times R_4 / (R_3 + R_4) \text{ [V]}$ However, set the NON2 pin voltage to 0.3 to 2.0 V.	
<ul style="list-style-type: none"> • Inverting (CH2) $V_{o2} = 2.5 - \{(2.5 - V_{INV2}) \times (R_1 + R_2) / R_1\} \text{ [V]}$ $V_{INV2} = 2.5 \times R_4 / (R_3 + R_4) \text{ [V]}$ However, set the INV2 pin voltage to 0.3 to 2.0 V	

● **Setting of oscillation frequency (BD9850FVM)**

Connecting a resistor to the RT pin (pin 2) allows for the setting of oscillation frequency.

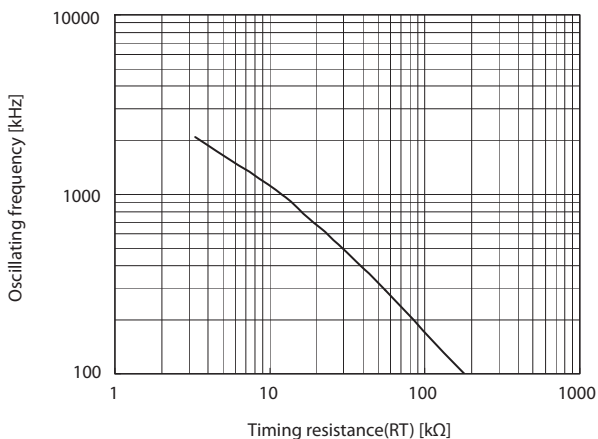

Fig.18 RT vs. Oscillation frequency

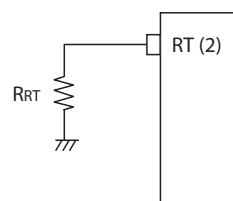

Fig.17 Setting procedure for BD9850FVM oscillation frequency

• Setting of oscillation frequency (BD9851EFV)

Connecting a resistor to the RT pin (pin 2) and a capacitor to the CT pin allows for the setting of oscillation frequency.

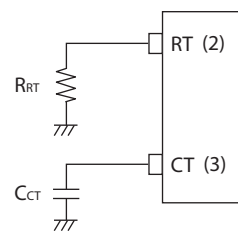

Fig. 19 Setting procedure for BD9851EFV oscillation frequency

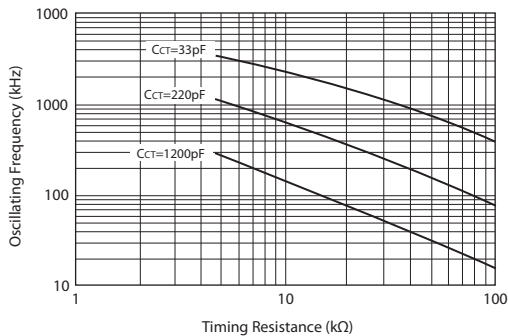

Fig. 20 RT vs. Oscillation frequency

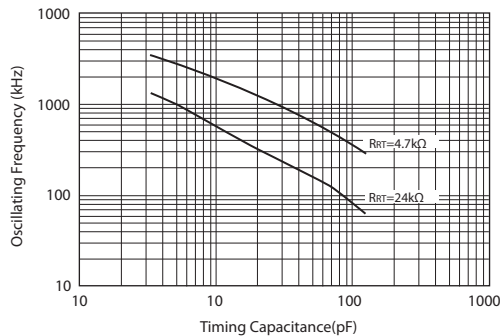

Fig. 20 CT vs. Oscillation frequency

• Setting of timer of short circuit protection circuit (BD9851EFV)

Setting procedure	Application
$T_{SCP} = 7.45 \times 10^5 \times C_{SCP}$ <p> T_{SCP} : Time from output short circuit to latch stop [sec] C_{SCP} : Capacitance of capacitor between the SCP and GND pins [F] </p>	

• Setting of maximum duty (BD9851EFV)

Setting procedure

$$DUTY(max.) = 100 \times (V_{DTC} - V_{th0}) / (V_{th100} - V_{th0})$$

$$V_{DTC} = 2.5 \times R2 / (R1 + R2)$$

$DUTY(max.)$: Maximum duty [%]
 V_{DTC} : DTC pin voltage [V]
 V_{th0} : 0% duty threshold voltage [V]
 V_{th100} : 100% duty threshold voltage [V]

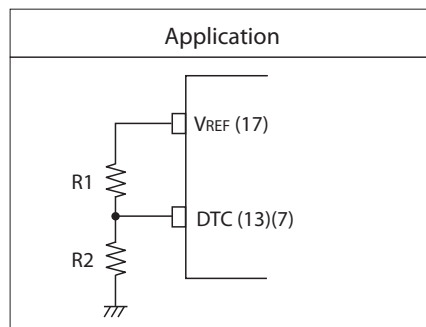

• Pin treatment of unused channels (BD9851EFV)

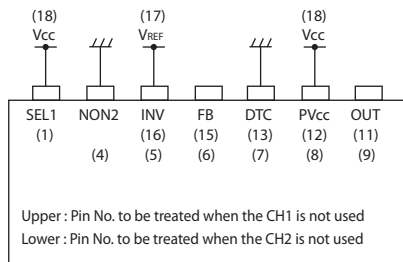

Fig. 22 Pin treatment procedure for unused channel on BD9851EFV

In order to use one channel, treat the pins of unused channel as shown above.

● Application circuit / Directions for pattern layout
(BD9850FVM)

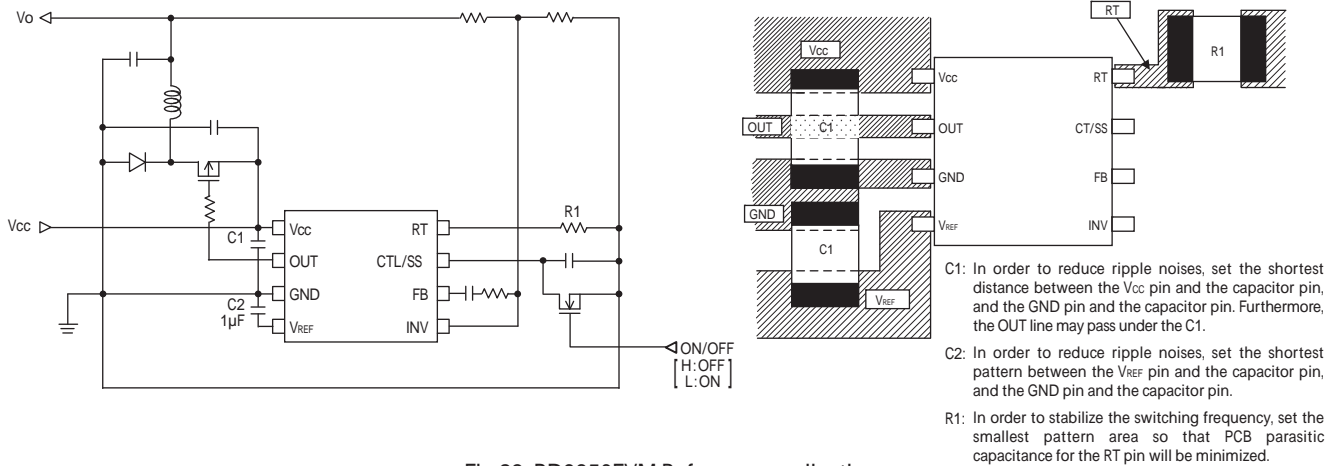

Fig.23 BD9850FVM Reference application

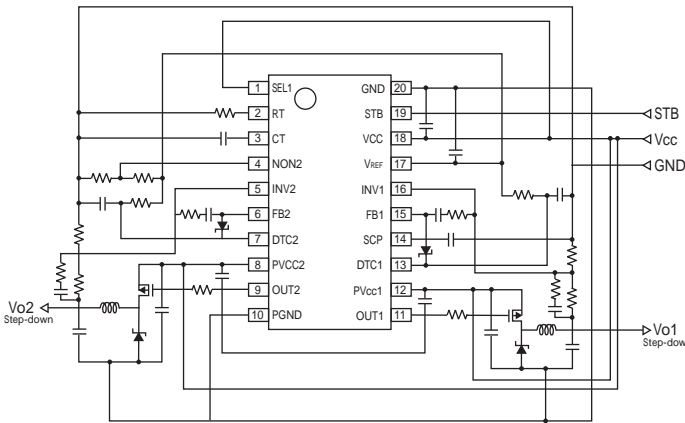

Fig.24 Step-down/Step-up application

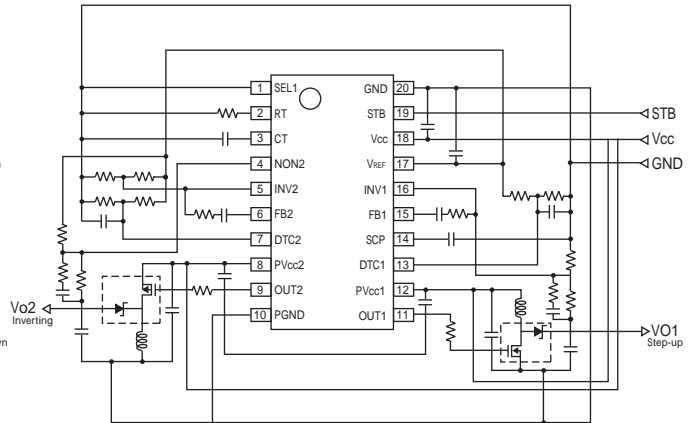

Fig.25 Step-up/Inverting application

● Equivalent circuit
(BD9850FVM)

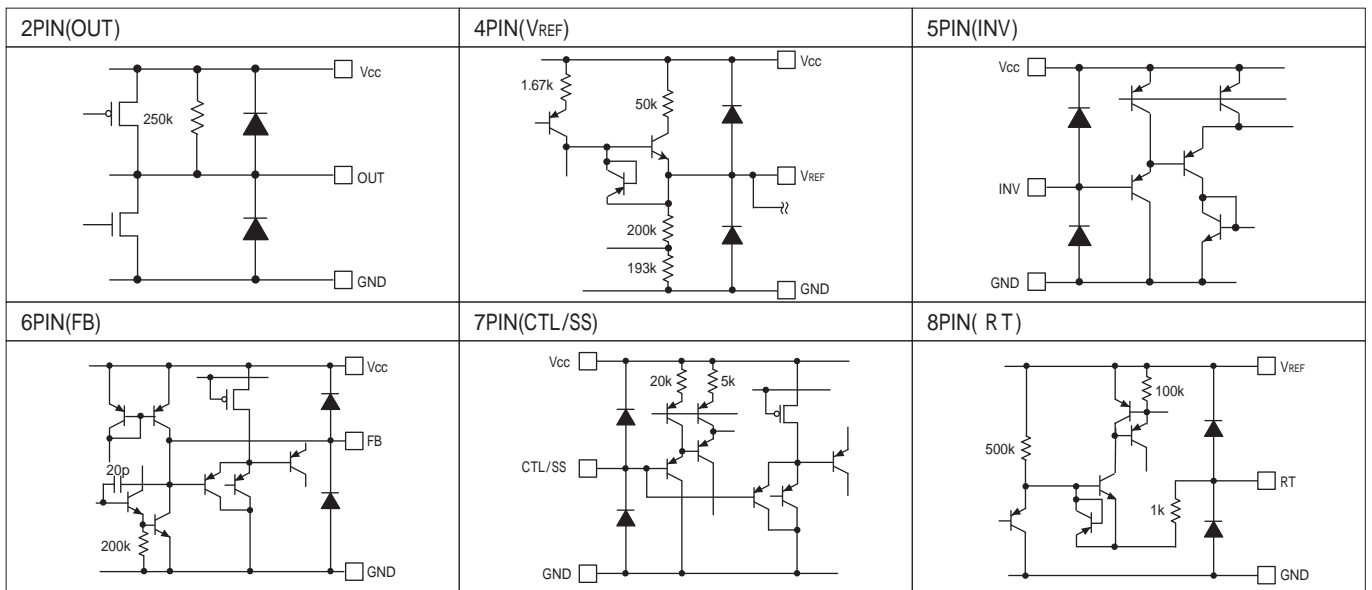

Fig.26 Equivalent circuit (BD9850FVM)

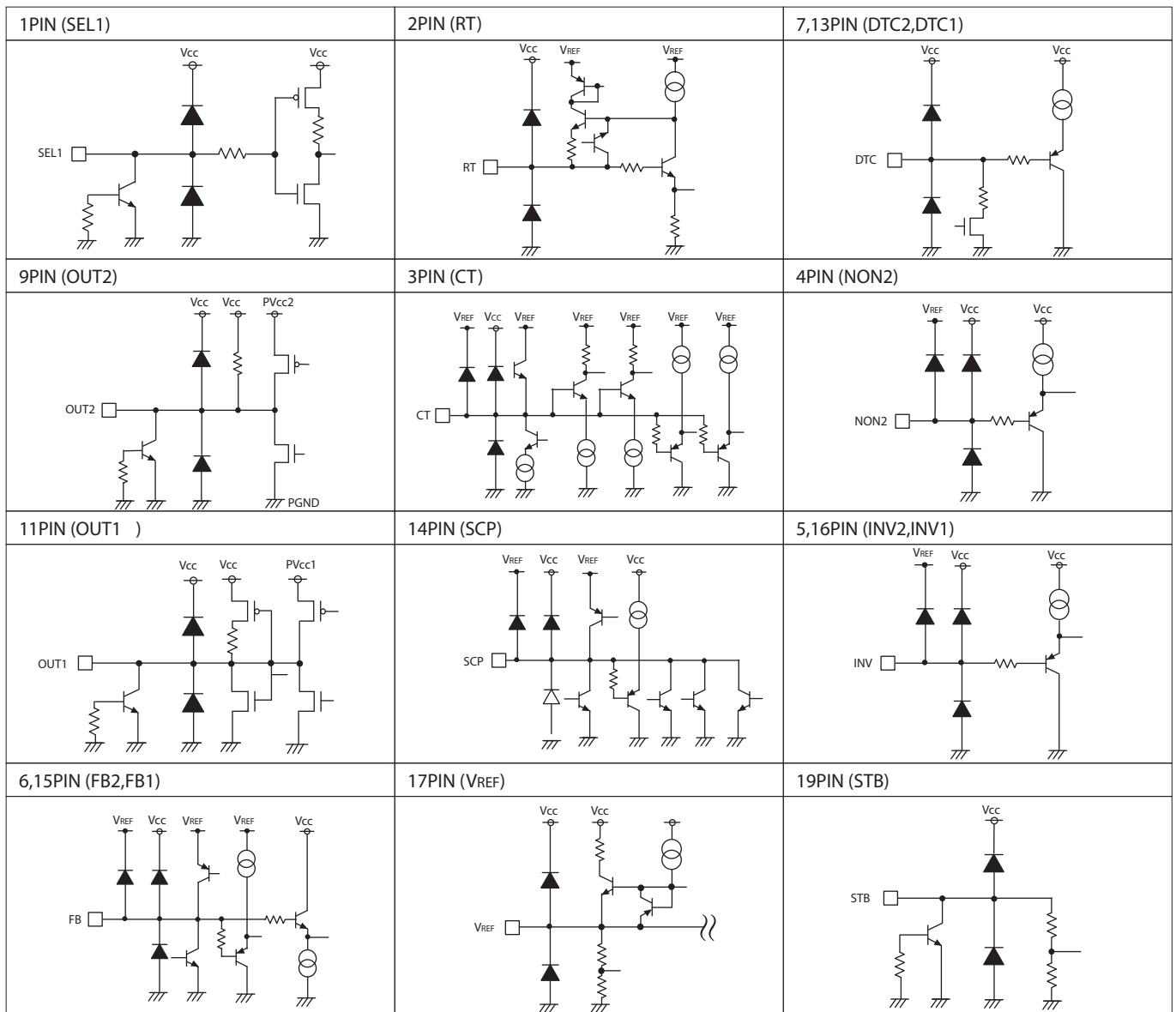

Fig.27 Equivalent circuit (BD9851EFV)

● Cautions on use

- 1) Absolute maximum ratings
An excess in the absolute maximum ratings, such as supply voltage, temperature range of operating conditions, etc., can break down the devices, thus making impossible to identify breaking mode, such as a short circuit or an open circuit. If any over rated values will expect to exceed the absolute maximum ratings, consider adding circuit protection devices, such as fuses.
- 2) GND potential
Ground-GND potential should maintain at the minimum ground voltage level. Furthermore, no terminals should be lower than the GND potential voltage including an electric transients.
- 3) Thermal design
Use a thermal design that allows for a sufficient margin in light of the power dissipation (Pd) in actual operating conditions.
- 4) Inter-pin shorts and mounting errors
Use caution when positioning the IC for mounting on printed circuit boards. The IC may be damaged if there is any connection error or if positive and ground power supply terminals are reversed. The IC may also be damaged if pins are shorted together or are shorted to other circuit's power lines.
- 5) Operation in strong electromagnetic field
Use caution when using the IC in the presence of a strong electromagnetic field as doing so may cause the IC to malfunction.
- 6) Thermal shutdown circuit (TSD circuit)
The IC incorporates a built-in thermal shutdown circuit (TSD circuit). The thermal shutdown circuit (TSD circuit) is designed only to shut the IC off to prevent runaway thermal operation. It is not designed to protect the IC or guarantee its operation. Do not continue to use the IC after operating this circuit or use the IC in an environment where the operation of this circuit is assumed.
- 7) Testing on application boards
When testing the IC on an application board, connecting a capacitor to a pin with low impedance subjects the IC to stress. Always discharge capacitors after each process or step. Always turn the IC's power supply off before connecting it to, or removing it from a jig or fixture, during the inspection process. Ground the IC during assembly steps as an antistatic measure. Use similar precaution when transporting and storing the IC.

8) IC pin input

This monolithic IC contains P+ isolation and P substrate layers between adjacent elements to keep them isolated. Pin junctions are formed at the intersection of these P layers with the N layers of other elements, creating a parasitic diode or transistor. For example, the relation between each potential is as follows:

When $GND > Pin A$ and $GND > Pin B$, the Pin junction operates as a parasitic diode.

When $Pin B > GND > Pin A$, the PnN junction operates as a parasitic transistor.

Parasitic diodes can occur inevitably in the structure of the IC. The operation of parasitic diodes can result in mutual interference among circuits, operational faults, or physical damage. Accordingly, methods by which parasitic diodes operate, such as applying a voltage that is lower than the GND (P substrate) voltage to an input pin, should not be used.

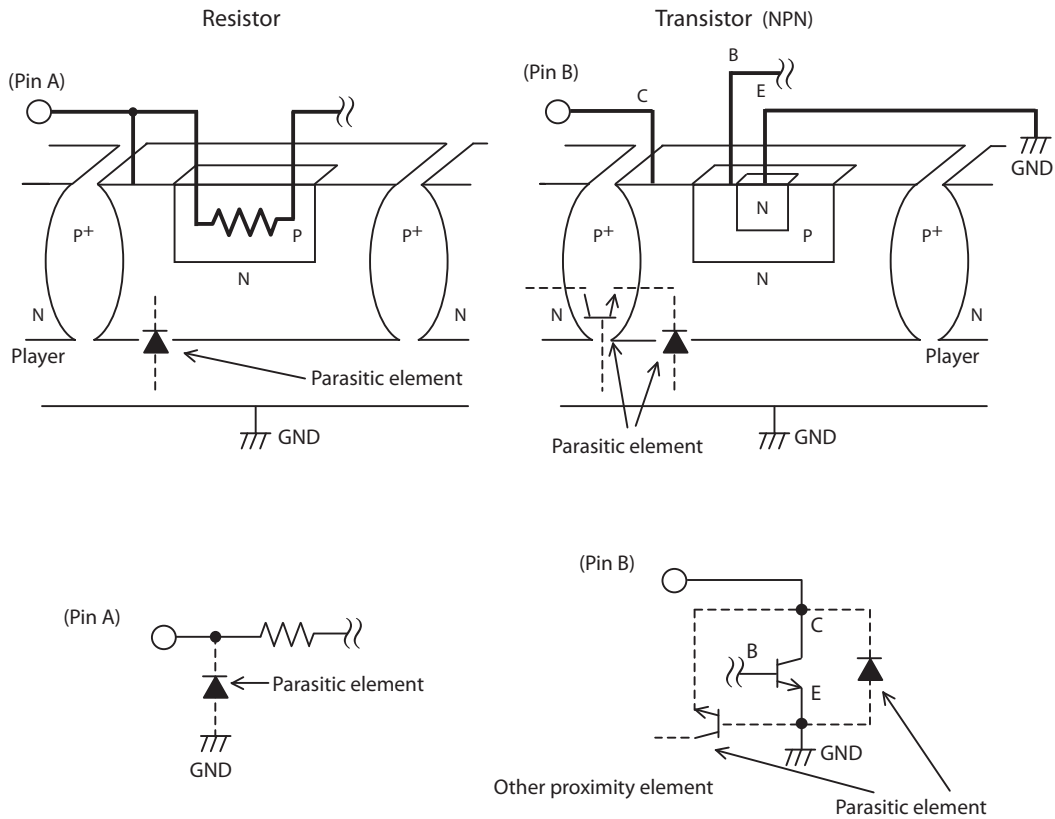

Fig. 28 Typical simple construction of monolithic IC

9) Common impedance

The power supply and ground lines must be as short and thick as possible to reduce line impedance. Fluctuating voltage on the power ground line may damage the device.

10) On the application shown below, Vcc is short-circuited to the Ground with external diode charged, internal circuits may be damaged. recommended to insert a backflow prevention diode in series with the Vcc or a bypass diode between each pin and Vcc.

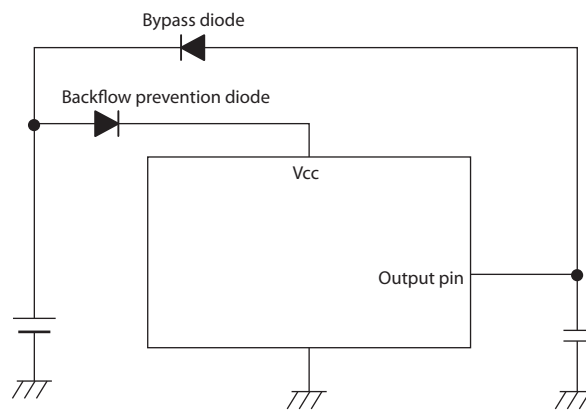

Fig. 29

- 11) Although ROHM is confident that the example application circuit reflects the best possible recommendations, be sure to verify circuit characteristics for your particular application. Modification of constants for other externally connected circuits may cause variations in both static and transient characteristics for external components as well as this Rohm IC. Allow for sufficient margins when determining circuit constants.

Oscillation frequency setting resistor

- 12) For the oscillation frequency setting resistor to be inserted between the RT pin and the GND pin, mount this resistor close to the RT pin and provide the shortest pattern routing.

● Thermal derating characteristics

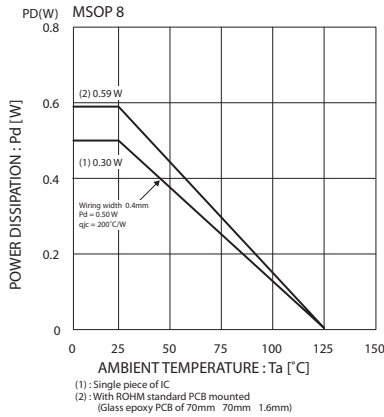

Fig.30

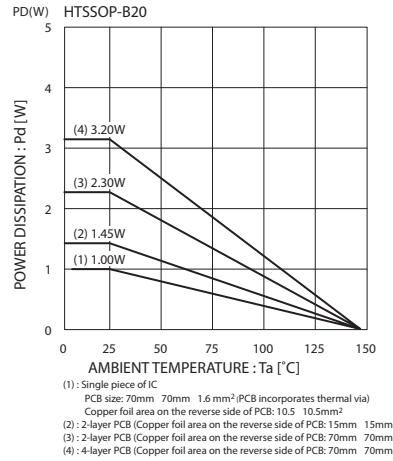
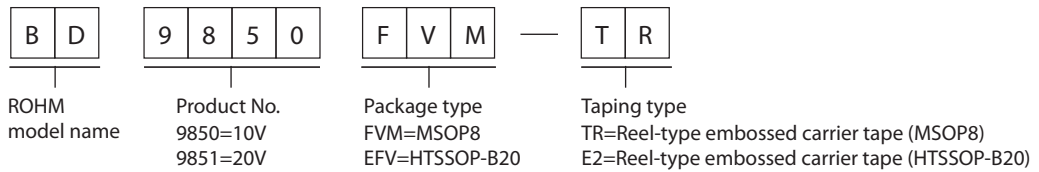
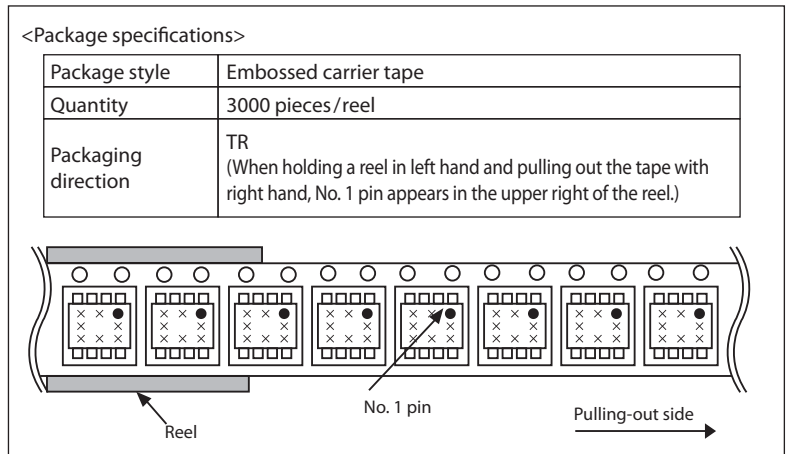
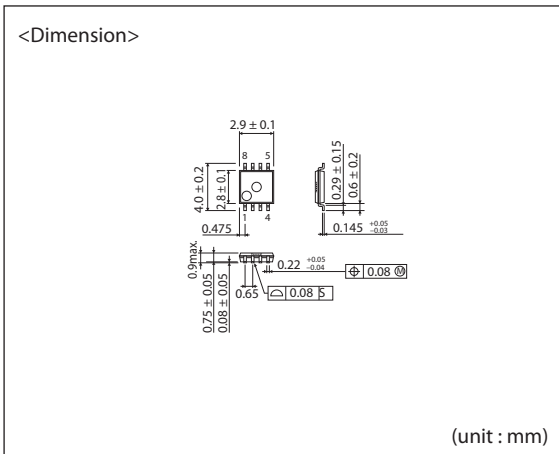

Fig.31

● Selection of order type



MSOP8



HTSSOP-B20

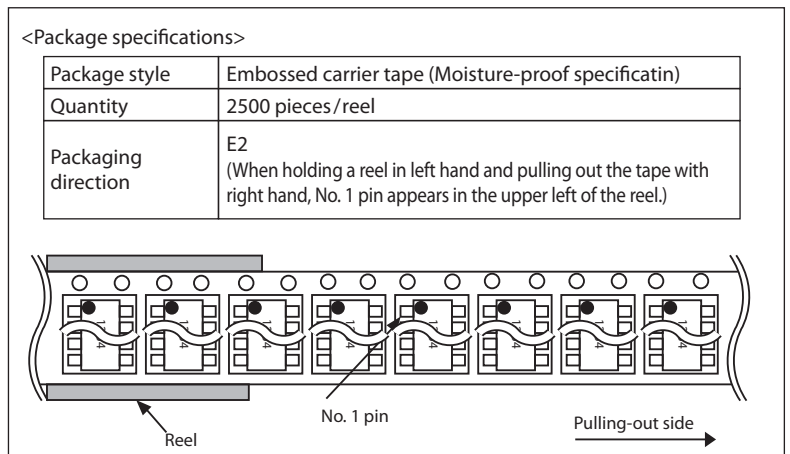
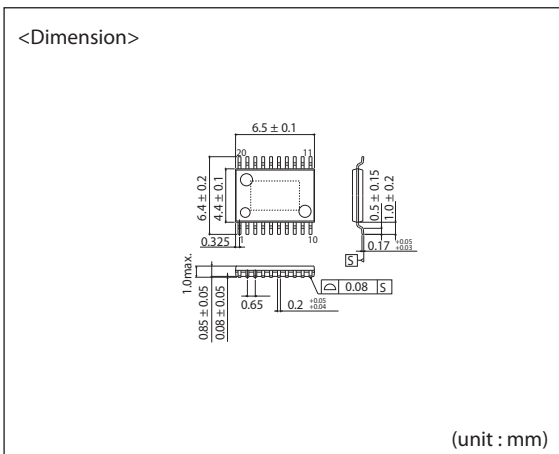

- The contents described herein are correct as of September, 2008
- The contents described herein are subject to change without notice. For updates of the latest information, please contact and confirm with ROHM CO.,LTD.
- Any part of this application note must not be duplicated or copied without our permission.
- Application circuit diagrams and circuit constants contained herein are shown as examples of standard use and operation. Please pay careful attention to the peripheral conditions when designing circuits and deciding upon circuit constants in the set.
- Any data, including, but not limited to application circuit diagrams and information, described herein are intended only as illustrations of such devices and not as the specifications for such devices. ROHM CO.,LTD. disclaims any warranty that any use of such devices shall be free from infringement of any third party's intellectual property rights or other proprietary rights, and further, assumes no liability of whatsoever nature in the event of any such infringement, or arising from or connected with or related to the use of such devices.
- Upon the sale of any such devices, other than for buyer's right to use such devices itself, resell or otherwise dispose of the same, implied right or license to practice or commercially exploit any intellectual property rights or other proprietary rights owned or controlled by ROHM CO., LTD. is granted to any such buyer.
- The products described herein utilize silicon as the main material.
- The products described herein are not designed to be X ray proof.

The products listed in this catalog are designed to be used with ordinary electronic equipment or devices (such as audio visual equipment, office-automation equipment, communications devices, electrical appliances and electronic toys). Should you intend to use these products with equipment or devices which require an extremely high level of reliability and the malfunction of which would directly endanger human life (such as medical instruments, transportation equipment, aerospace machinery, nuclear-reactor controllers, fuel controllers and other safety devices), please be sure to consult with our sales representative in advance.

Contact us for further information about the products.

San Diego	TEL: +1-858-625-3630	FAX: +1-858-625-3670	Tianjin	TEL: +86-22-23029181	FAX: +86-22-23029183
Atlanta	TEL: +1-770-754-5972	FAX: +1-770-754-0691	Shanghai	TEL: +86-21-6279-2727	FAX: +86-21-6247-2066
Boston	TEL: +1-978-371-0382	FAX: +1-928-438-7164	Hangzhou	TEL: +86-571-87658072	FAX: +86-571-87658071
Chicago	TEL: +1-847-368-1006	FAX: +1-847-368-1008	Nanjing	TEL: +86-25-8689-0015	FAX: +86-25-8689-0393
Dallas	TEL: +1-469-287-5366	FAX: +1-469-362-7973	Ningbo	TEL: +86-574-87654201	FAX: +86-574-87654208
Denver	TEL: +1-303-708-0908	FAX: +1-303-708-0858	Qingdao	TEL: +86-532-5779-312	FAX: +86-532-5779-653
Detroit	TEL: +1-248-348-9920	FAX: +1-248-348-9942	Suzhou	TEL: +86-512-6807-1300	FAX: +86-512-6807-2300
Nashville	TEL: +1-615-620-6700	FAX: +1-615-620-6702	Wuxi	TEL: +86-510-82702693	FAX: +86-510-82702992
Mexico	TEL: +52-33-3123-2001	FAX: +52-33-3123-2002	Shenzhen	TEL: +86-769-8307-3008	FAX: +86-769-8307-3003
Düsseldorf	TEL: +49-2154-9210	FAX: +49-2154-921400	Dongguan	TEL: +86-769-8393-3320	FAX: +86-769-8398-4140
Munich	TEL: +49-8999-216168	FAX: +49-8999-216176	Fuzhou	TEL: +86-591-8801-8698	FAX: +86-591-8801-8690
Stuttgart	TEL: +49-711-7272-370	FAX: +49-711-7272-3720	Guangzhou	TEL: +86-20-3878-8100	FAX: +86-20-3825-5965
France	TEL: +33-1-5697-3060	FAX: +33-1-5697-3080	Huizhou	TEL: +86-752-205-1054	FAX: +86-752-205-1059
United Kingdom	TEL: +44-1-908-306700	FAX: +44-1-908-235788	Xiamen	TEL: +86-592-238-5705	FAX: +86-592-239-8380
Denmark	TEL: +45-3694-4739	FAX: +45-3694-4789	Zhuhai	TEL: +86-756-3232-480	FAX: +86-756-3232-460
Espoo	TEL: +358-9725-54491	FAX: +358-9-7255-4499	Hong Kong	TEL: +852-2-740-6262	FAX: +852-2-375-8971
Salo	TEL: +358-2-7332234	FAX: +358-2-7332237	Taipei	TEL: +886-2-2500-6956	FAX: +886-2-2503-2869
Oulu	TEL: +358-9-5372930	FAX: +358-8-5372931	Kaohsiung	TEL: +886-7-237-0881	FAX: +886-7-238-7332
Barcelona	TEL: +34-9375-24320	FAX: +34-9375-24410	Singapore	TEL: +65-6332-2322	FAX: +65-6332-5662
Hungary	TEL: +36-1-4719338	FAX: +36-1-4719339	Philippines	TEL: +63-2-807-6872	FAX: +63-2-809-1422
Poland	TEL: +48-22-5757213	FAX: +48-22-5757001	Thailand	TEL: +66-2-254-4890	FAX: +66-2-256-6334
Russia	TEL: +7-495-739-41-74	FAX: +7-495-739-41-74	Kuala Lumpur	TEL: +60-3-7958-8355	FAX: +60-3-7958-8377
Seoul	TEL: +82-2-8182-700	FAX: +82-2-8182-715	Penang	TEL: +60-4-2286453	FAX: +60-4-2286452
Masan	TEL: +82-55-240-6234	FAX: +82-55-240-6236	Kyoto	TEL: +81-75-365-1218	FAX: +81-75-365-1228
Dalian	TEL: +86-411-8230-8549	FAX: +86-411-8230-8537	Yokohama	TEL: +81-45-476-2290	FAX: +81-45-476-2295
Beijing	TEL: +86-10-8525-2483	FAX: +86-10-8525-2489			

Excellence in Electronics

ROHM

ROHM CO., LTD.

21 Saiin Mizosaki-cho, Ukyo-ku, Kyoto
615-8585, Japan
TEL: +81-75-311-2121 FAX: +81-75-315-0172
URL <http://www.rohm.com>

Published by
KTC LSI Development Headquarters
LSI Business Promotion Group

Notice

Precaution on using ROHM Products

- Our Products are designed and manufactured for application in ordinary electronic equipments (such as AV equipment, OA equipment, telecommunication equipment, home electronic appliances, amusement equipment, etc.). If you intend to use our Products in devices requiring extremely high reliability (such as medical equipment ^(Note 1), transport equipment, traffic equipment, aircraft/spacecraft, nuclear power controllers, fuel controllers, car equipment including car accessories, safety devices, etc.) and whose malfunction or failure may cause loss of human life, bodily injury or serious damage to property ("Specific Applications"), please consult with the ROHM sales representative in advance. Unless otherwise agreed in writing by ROHM in advance, ROHM shall not be in any way responsible or liable for any damages, expenses or losses incurred by you or third parties arising from the use of any ROHM's Products for Specific Applications.

(Note1) Medical Equipment Classification of the Specific Applications

JAPAN	USA	EU	CHINA
CLASS III	CLASS III	CLASS II b	CLASS III
CLASS IV		CLASS III	

- ROHM designs and manufactures its Products subject to strict quality control system. However, semiconductor products can fail or malfunction at a certain rate. Please be sure to implement, at your own responsibilities, adequate safety measures including but not limited to fail-safe design against the physical injury, damage to any property, which a failure or malfunction of our Products may cause. The following are examples of safety measures:
 - Installation of protection circuits or other protective devices to improve system safety
 - Installation of redundant circuits to reduce the impact of single or multiple circuit failure
- Our Products are designed and manufactured for use under standard conditions and not under any special or extraordinary environments or conditions, as exemplified below. Accordingly, ROHM shall not be in any way responsible or liable for any damages, expenses or losses arising from the use of any ROHM's Products under any special or extraordinary environments or conditions. If you intend to use our Products under any special or extraordinary environments or conditions (as exemplified below), your independent verification and confirmation of product performance, reliability, etc. prior to use, must be necessary:
 - Use of our Products in any types of liquid, including water, oils, chemicals, and organic solvents
 - Use of our Products outdoors or in places where the Products are exposed to direct sunlight or dust
 - Use of our Products in places where the Products are exposed to sea wind or corrosive gases, including Cl₂, H₂S, NH₃, SO₂, and NO₂
 - Use of our Products in places where the Products are exposed to static electricity or electromagnetic waves
 - Use of our Products in proximity to heat-producing components, plastic cords, or other flammable items
 - Sealing or coating our Products with resin or other coating materials
 - Use of our Products without cleaning residue of flux (even if you use no-clean type fluxes, cleaning residue of flux is recommended); or Washing our Products by using water or water-soluble cleaning agents for cleaning residue after soldering
 - Use of the Products in places subject to dew condensation
- The Products are not subject to radiation-proof design.
- Please verify and confirm characteristics of the final or mounted products in using the Products.
- In particular, if a transient load (a large amount of load applied in a short period of time, such as pulse. is applied, confirmation of performance characteristics after on-board mounting is strongly recommended. Avoid applying power exceeding normal rated power; exceeding the power rating under steady-state loading condition may negatively affect product performance and reliability.
- De-rate Power Dissipation (Pd) depending on Ambient temperature (Ta). When used in sealed area, confirm the actual ambient temperature.
- Confirm that operation temperature is within the specified range described in the product specification.
- ROHM shall not be in any way responsible or liable for failure induced under deviant condition from what is defined in this document.

Precaution for Mounting / Circuit board design

- When a highly active halogenous (chlorine, bromine, etc.) flux is used, the residue of flux may negatively affect product performance and reliability.
- In principle, the reflow soldering method must be used; if flow soldering method is preferred, please consult with the ROHM representative in advance.

For details, please refer to ROHM Mounting specification

Precautions Regarding Application Examples and External Circuits

1. If change is made to the constant of an external circuit, please allow a sufficient margin considering variations of the characteristics of the Products and external components, including transient characteristics, as well as static characteristics.
2. You agree that application notes, reference designs, and associated data and information contained in this document are presented only as guidance for Products use. Therefore, in case you use such information, you are solely responsible for it and you must exercise your own independent verification and judgment in the use of such information contained in this document. ROHM shall not be in any way responsible or liable for any damages, expenses or losses incurred by you or third parties arising from the use of such information.

Precaution for Electrostatic

This Product is electrostatic sensitive product, which may be damaged due to electrostatic discharge. Please take proper caution in your manufacturing process and storage so that voltage exceeding the Products maximum rating will not be applied to Products. Please take special care under dry condition (e.g. Grounding of human body / equipment / solder iron, isolation from charged objects, setting of Ionizer, friction prevention and temperature / humidity control).

Precaution for Storage / Transportation

1. Product performance and soldered connections may deteriorate if the Products are stored in the places where:
 - [a] the Products are exposed to sea winds or corrosive gases, including Cl₂, H₂S, NH₃, SO₂, and NO₂
 - [b] the temperature or humidity exceeds those recommended by ROHM
 - [c] the Products are exposed to direct sunshine or condensation
 - [d] the Products are exposed to high Electrostatic
2. Even under ROHM recommended storage condition, solderability of products out of recommended storage time period may be degraded. It is strongly recommended to confirm solderability before using Products of which storage time is exceeding the recommended storage time period.
3. Store / transport cartons in the correct direction, which is indicated on a carton with a symbol. Otherwise bent leads may occur due to excessive stress applied when dropping of a carton.
4. Use Products within the specified time after opening a humidity barrier bag. Baking is required before using Products of which storage time is exceeding the recommended storage time period.

Precaution for Product Label

QR code printed on ROHM Products label is for ROHM's internal use only.

Precaution for Disposition

When disposing Products please dispose them properly using an authorized industry waste company.

Precaution for Foreign Exchange and Foreign Trade act

Since our Products might fall under controlled goods prescribed by the applicable foreign exchange and foreign trade act, please consult with ROHM representative in case of export.

Precaution Regarding Intellectual Property Rights

1. All information and data including but not limited to application example contained in this document is for reference only. ROHM does not warrant that foregoing information or data will not infringe any intellectual property rights or any other rights of any third party regarding such information or data. ROHM shall not be in any way responsible or liable for infringement of any intellectual property rights or other damages arising from use of such information or data.:
2. No license, expressly or implied, is granted hereby under any intellectual property rights or other rights of ROHM or any third parties with respect to the information contained in this document.

Other Precaution

1. This document may not be reprinted or reproduced, in whole or in part, without prior written consent of ROHM.
2. The Products may not be disassembled, converted, modified, reproduced or otherwise changed without prior written consent of ROHM.
3. In no event shall you use in any way whatsoever the Products and the related technical information contained in the Products or this document for any military purposes, including but not limited to, the development of mass-destruction weapons.
4. The proper names of companies or products described in this document are trademarks or registered trademarks of ROHM, its affiliated companies or third parties.

General Precaution

1. Before you use our Products, you are requested to carefully read this document and fully understand its contents. ROHM shall not be in any way responsible or liable for failure, malfunction or accident arising from the use of any ROHM's Products against warning, caution or note contained in this document.
2. All information contained in this document is current as of the issuing date and subject to change without any prior notice. Before purchasing or using ROHM's Products, please confirm the latest information with a ROHM sales representative.
3. The information contained in this document is provided on an "as is" basis and ROHM does not warrant that all information contained in this document is accurate and/or error-free. ROHM shall not be in any way responsible or liable for any damages, expenses or losses incurred by you or third parties resulting from inaccuracy or errors of or concerning such information.

X-ON Electronics

Largest Supplier of Electrical and Electronic Components

Click to view similar products for [Switching Controllers](#) category:

Click to view products by [ROHM](#) manufacturer:

Other Similar products are found below :

[AZ7500EP-E1](#) [NCP1218AD65R2G](#) [NCP1234AD100R2G](#) [NCP1244BD065R2G](#) [NCP1336ADR2G](#) [NCP6153MNTWG](#) [NCP81101BMNTXG](#)
[NCP81205MNTXG](#) [SJE6600](#) [SMBV1061LT1G](#) [SG3845DM](#) [NCP4204MNTXG](#) [NCP6132AMNR2G](#) [NCP81102MNTXG](#)
[NCP81203MNTXG](#) [NCP81206MNTXG](#) [NX2155HCUPTR](#) [UBA2051C](#) [FSL4110LRLX](#) [MAX8778ETJ+](#) [NTBV30N20T4G](#)
[NCP1240AD065R2G](#) [NCP1240FD065R2G](#) [NCP1361BABAYSNT1G](#) [NTC6600NF](#) [NCP1230P100G](#) [NCP1612BDR2G](#) [NX2124CSTR](#)
[SG2845M](#) [NCP81101MNTXG](#) [TEA19362T/1J](#) [IFX81481ELV](#) [NCP81174NMNTXG](#) [NCP4308DMTTWG](#) [NCP4308DMNTWG](#)
[NCP4308AMTTWG](#) [NCP1251FSN65T1G](#) [NCP1246BLD065R2G](#) [NTE7154](#) [NTE7242](#) [LTC7852IUFD-1#PBF](#) [LTC7852EUFD-1#PBF](#)
[MB39A136PFT-G-BND-ERE1](#) [NCP1256BSN100T1G](#) [LV5768V-A-TLM-E](#) [NCP1365BABCYDR2G](#) [NCP1365AABCYDR2G](#) [MCP1633T-](#)
[E/MG](#) [NCV1397ADR2G](#) [NCP1246ALD065R2G](#)