

Single-chip Type with Built-in FET Switching Regulators

Simple Step-down Switching Regulators with Built-in Power MOSFET

BD9G101G

General Description

The BD9G101G is high voltage input 42V step-down switching regulator with integrated internal Power MOSFET. It provides maximum 0.5A output with small SSOP6 package. It is allowing the use of small inductor by high frequency operation of 1.5MHz. Also, it is implemented to downsize by incorporation of phase compensation parts with current mode.

Features

- High and Wide Input Voltage Range (VCC=6V to 42V)
- 45V/800mΩ Internal Power Nch-FET
- 1.5MHz Fixed Operating High Frequency
- Built-in Reference Voltage 0.75V±1.5% circuit
- Built-in Phase Compensation circuit
- Internal Over Current protection, Under Voltage Lock Out, Thermal shutdown
- Stand-by function (I_{st}=0μA)
- Small package SSOP6

Key Specifications

- Input Voltage 6V to 42 V
- Reference Voltage Precision (Ta=25°C) ±1.5 %
(Ta=-25°C to 105°C) ±2.0 %
- Max Output Current 0.5 A (Max)
- Operating Temperature -40°C to +105°C
- Max Junction Temperature 150°C

Packages

SSOP6

W(Typ) x D(Typ) x H(Max)
2.90mm x 2.80mm x 1.25mm

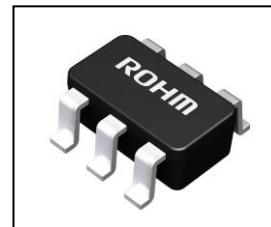

SSOP6

Applications

- Industrial distributed power applications
- Battery powered equipment
- OA instruments

Typical Application Circuits

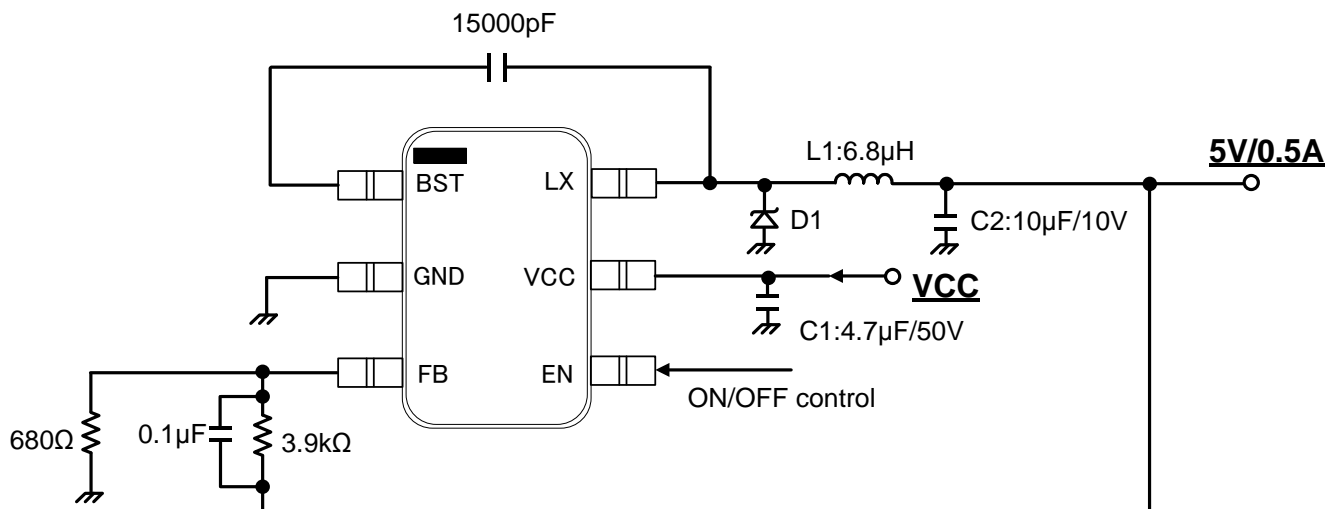

Figure 1. Typical Application Circuit

Pin Configuration

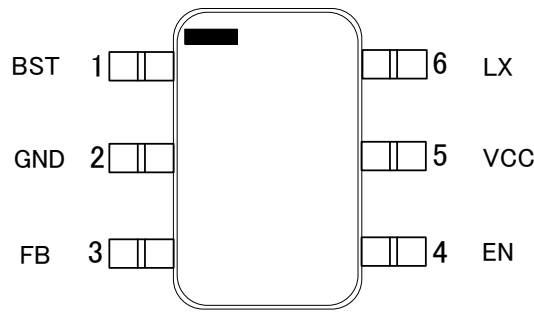

Figure 2. Pin Configuration (TOP VIEW)

Pin Description

Pin No.	Pin Name	Description
1	BST	The pin is power supply for floating Power Nch-FET driver. Connected 15000pF between this pin and LX pin for bootstrap operation.
2	GND	Ground.
3	FB	Voltage feedback pin. This pin is error-amplifier input, the DCDC is set 0.75V at this pin with feed-back operation.
4	EN	ON/OFF pin. The IC is start-up to apply 2.0V or over. This pin has pull-down resistor 550kΩ, the IC is shutdown to open or apply 0.8V or under.
5	VCC	Input supply. It should be connected as near as possible to the bypass capacitor. It should be increased impedance by thick PCB pattern.
6	LX	Power Nch-FET switching node pin. It should be connected as near as possible to the schottky barrier diode, and inductor.

Block Diagram

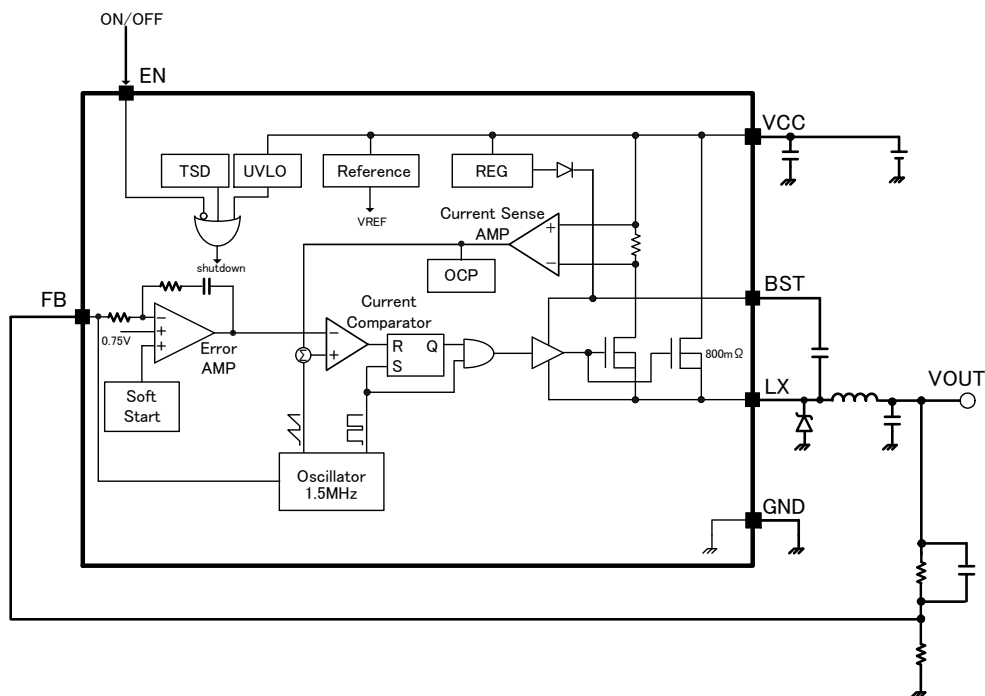

Figure 3. Block Diagram

Description of Blocks

1. Reference
This block generates reference voltage. It starts operation by applying EN 2.0V or more.
It provides reference voltage and error-amplifier 0.75V, oscillator, current and etc.
2. REG
This is a gate drive voltage generator and 4.2V regulator for internal circuit power supply.
3. OSC
It is generated rectangular wave of 1.5MHz with operation frequency of normal time.
To protect over current from output shorted to GND, the frequency is changed depending on FB voltage by the Frequency fold-back function.
4. Soft Start
This block does Soft Start to the output voltage of DC/DC comparator, and prevents in-rush current during Start-up.
Soft Start Time depend on application start-condition because the Frequency fold-back function is built-in. The Frequency fold-back function changes frequency by FB voltage.
5. ERROR AMP
This is an error-amplifier what detects output signal, and outputs PWM control signal.
Internal reference voltage is set to 0.75V. Also, the BD9G101G has internal phase compensated element between input and output.
6. Current Comparator
This is a comparator that outputs PWM signal from current feed-back signal and error-amplifier output for current-mode.
7. Nch-FET SW
This is an 45V/800mΩ Power Nch-FET SW that converts inductor current of DC/DC converter.
8. UVLO
This is a low voltage error prevention circuit.
This prevents internal circuit error during increase of power supply voltage and during decline of power supply voltage.
It monitors VCC pin voltage, and when VCC voltage becomes 5.4V and below, it turns OFF DC/DC converter output, and Soft Start circuit resets.
Now this threshold has hysteresis of 200mV.
9. EN
When a Voltage of 2.0V or more is applied, it turns ON. at open or 0.8V or under applied, it turns OFF.
550kΩ (Typ) Pull-down Resistance is contained in the Pin.
10. OCP
This is Over Current protection.
It monitors current of high-side Nch-FET. If the current is 1.2A (Typ) or more, this function reduce duty by pulse-by-pulse and restrict the over current.
11. TSD
This is circuit for preventing malfunction at high Temperature.
When it detects an abnormal temperature $T_j=175^{\circ}\text{C}$, it turns OFF DC/DC Converter Output. The protection circuit has Hysteresis (25°C). It prevents malfunction by changing near threshold.

Absolute Maximum Ratings

Item	Symbol	Ratings	Unit
VCC to GND	VCC	45	V
BST to GND	VBST	50	V
Maximum rating current	I _{max}	1.0	A
BST to LX	ΔVBST	7	V
EN to GND	VEN	45	V
LX to GND	VLX	45	V
FB to GND	VFB	7	V
Power Dissipation	P _d	0.675 ^(*1)	W
Operating Temperature	T _{opr}	-40 to +105	°C
Storage Temperature	T _{stg}	-55 to +150	°C
Junction Temperature	T _{jmax}	150 ^(*2)	°C

(*1) During mounting of 70×70×1.6t mmt 1layer board. Reduce by 5.4mW for every 1°C increase. (25°C or more)

(*2) This is circuit for preventing malfunction at high Temperature.

When it detects an abnormal temperature T_j=175°C, it turns OFF DC/DC Converter Output.

The protection circuit has Hysteresis (25°C). It prevents malfunction by changing near threshold

Electrical Characteristics (Unless otherwise specified Ta=25°C, VCC=24V, VOUT=5V, EN=3V)

Parameter	Symbol	Limit			Unit	Condition
		Min	Typ	Max		
Circuit Current						
Stand-by Current	I _{st}	-	0	5	μA	VEN=0V
Operating Current	I _{cc}	-	0.7	1.2	mA	FB=1.2V
Under Voltage Lock Out (UVLO)						
Detect Threshold Voltage	V _{uv}	5.1	5.4	5.7	V	
Hysteresis width	V _{uvhy}	-	200	300	mV	
Oscillator						
Switching Frequency	F _{osc}	1.3	1.5	1.7	MHz	
Max Duty Cycle	D _{max}	85	-	-	%	
Error AMP						
FB Pin Threshold Voltage	VFBN	0.739	0.750	0.761	V	Ta=25°C
	VFBA	0.735	0.750	0.765	V	Ta=-25°C to 105°C
FB Pin Input Current	I _{FB}	-100	0	100	nA	VFB=2.0V
Soft-Start Time	T _{soft}	1.2	4.0	-	ms	
Current Comparator						
Trans-conductance	G _{cs}	-	3	-	A/V	
Output						
High-side Nch-FET ON Resistance	R _{onH}	-	800	-	mΩ	
Min ON Time	T _{min}	-	100	-	ns	
OCP Detect Current	I _{ocp}	0.85	1.2	-	A	
CTL						
EN Threshold Voltage	ON	VENON	2.0	-	VCC	V
	OFF	VENOFF	-0.3	-	0.8	V
EN Input Current	I _{EN}	2.7	5.5	11	μA	VEN=3V

Operating Ratings

Item	Symbol	Ratings			Unit
		Min	Typ	Max	
Input Voltage	VCC	6	-	42	V
Output Voltage	VOUT	1.0 ^(*3)	-	VCC x 0.7 ^(*4)	V
Output Current	IOUT	-	-	500	mA

(*3) Restricted by Min ON Time typ 100ns.
 (*4) Restricted by Max duty, RonH and BST-UVLO.

Output voltage range and Output voltage setting

BD9G101G is limited the range of use by Max duty (min85%), Min ON Time (Typ 100ns), high-side Nch-FET ON resistance (RonH) and low voltage protect (BST-UVLO) for drive voltage of high-side Nch-FET between BST and LX.

1. BST-UVLO

It is the function that secure gate voltage of Nch-FET and prevent malfunction of the IC. If the voltage between BST and LX is lower than 1.5V, Nch-FET is turned off and there is new pass to charge voltage VCC to BST. BST voltage is charged by VCC. If the voltage between BST and LX is upper than 1.8V, BST-UVLO is released.

The condition that BST-UVLO is working property is $VCC > (BST-UVLO + Vf) + VOUT$.

Therefore, maximum output voltage is restricted VCC -3V.

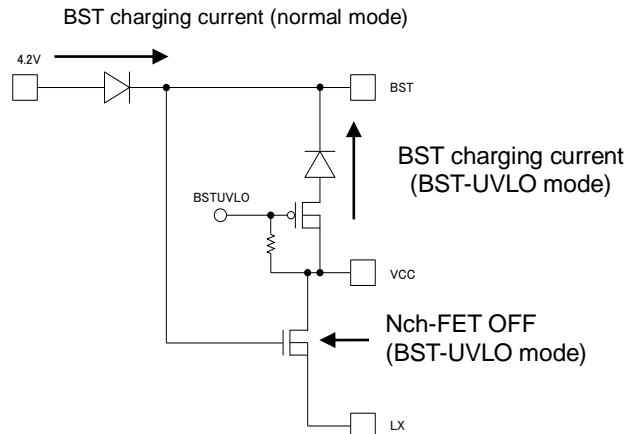

Figure 4. BST-UVLO equivalent circuit

*When operation can be considered by $VCC - VOUT < 3V$, output voltage leaps up to near input voltage by BST-UVLO operation at the time of a light load.

The waveform of operation and a mechanism are shown.

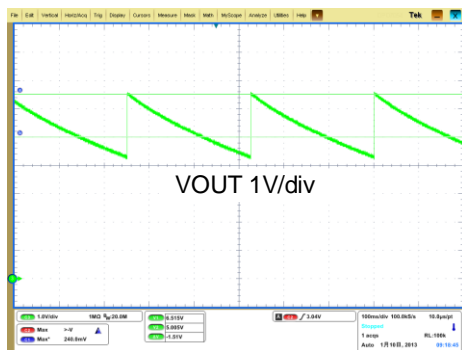
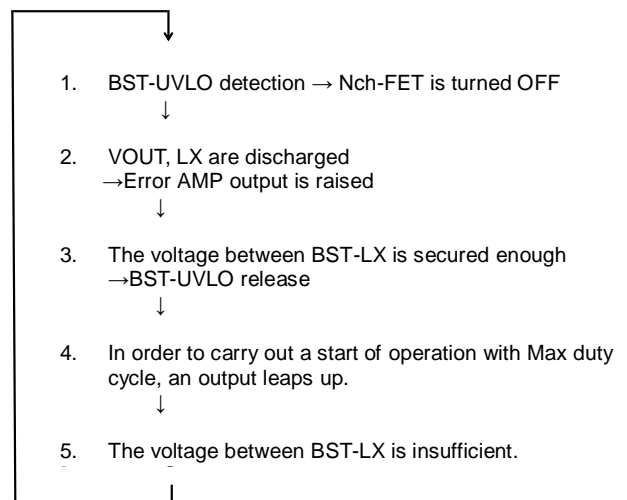

Figure 5. Low voltage and light load, BST-UVLO operation waveform
 VOUT=5V VCC=7V IOUT=0mA



Frequency fold-back function

This IC has the frequency fold-back function to prevent from over current when the output is shorted. The frequency fold-back has the function that the frequency is changed by FB voltage. Figure.7 shows FB voltage vs frequency Characteristics.

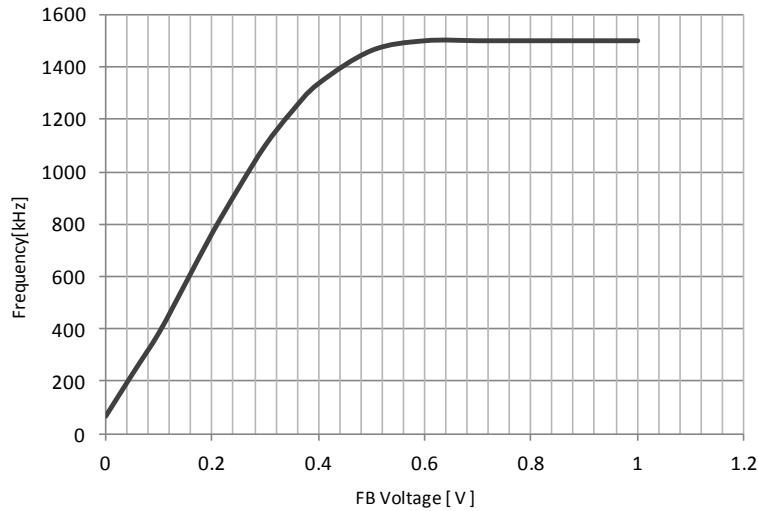

Figure 7. FB voltage -frequency Characteristics

When the output node is shorted, the IC narrows the frequency to about 150kHz(Typ) so that input current limiting. This IC operates on 1.5MHz in case of normal mode, the voltage of FB is about 0.75V.

Start-up Characteristics

When the IC is starting up, it gently raises FB voltage by Soft start function and prevent rush-current. FB voltage of starting up gently raises by synchronized internal clock. Because internal clock depends on FB voltage by frequency fold-back, Soft start time become faster in accordance with rising FB voltage.

Start-up characteristics depend on application condition such as load and output capacitor. Please check the using condition and refer the typical application waveform (P.11, P14) because of the Start-up characteristics changes to the output load and the output capacitor.

Typical Performance Characteristics

(Unless otherwise specified, $T_a=25^\circ\text{C}$, $V_{CC}=12\text{V}$, $V_{OUT}=5\text{V}$, $EN=3\text{V}$)

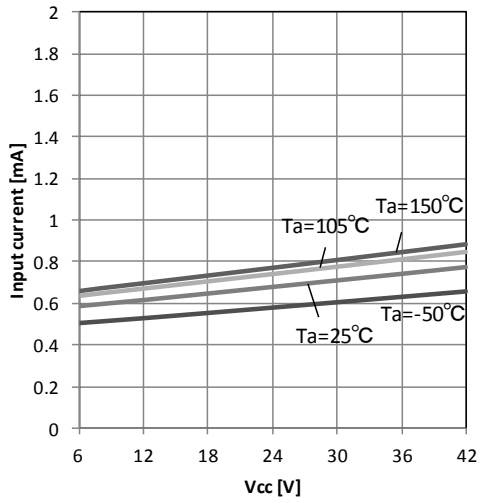

Figure 8. Operating Current - Input Voltage

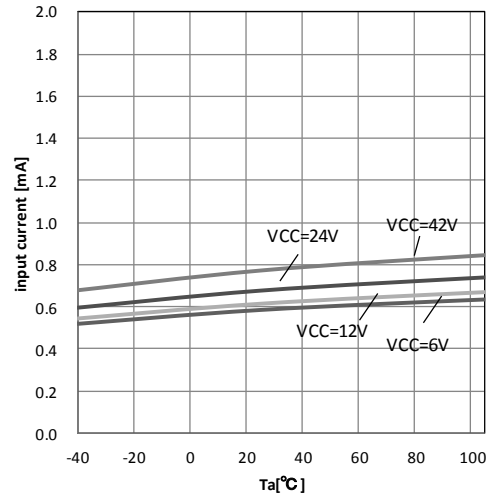

Figure 9. Operating Current - Temperature

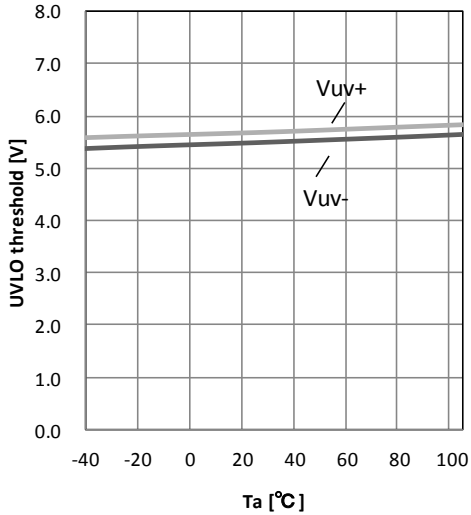

Figure 10. UVLO Threshold - Temperature

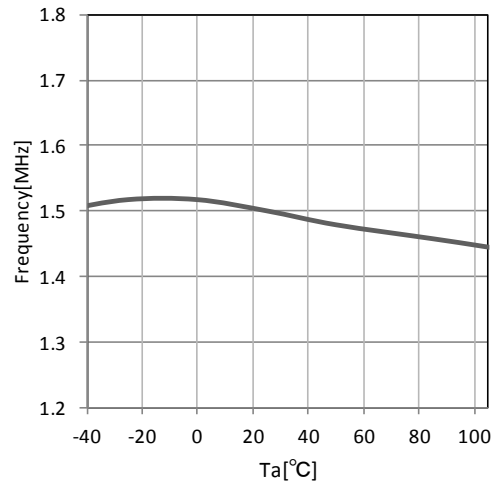

Figure 11. Oscillation frequency - Temperature

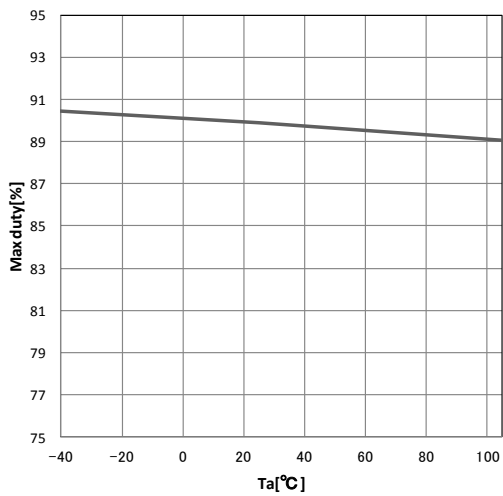

Figure 12. Max Duty - Temperature

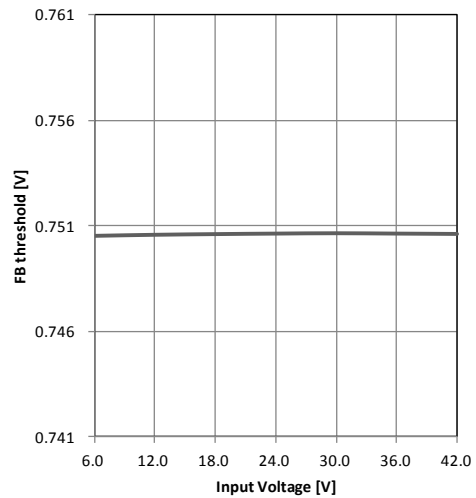

Figure 13. FB Pin Reference Voltage – Input Voltage

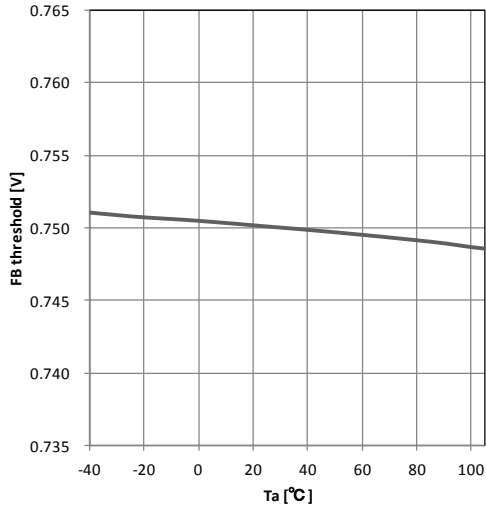

Figure 14. FB Threshold - Temperature

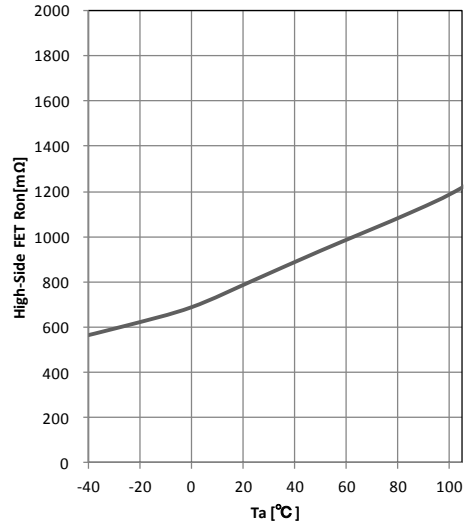

Figure 15. High-side Nch-FET ON Resistance - Temperature

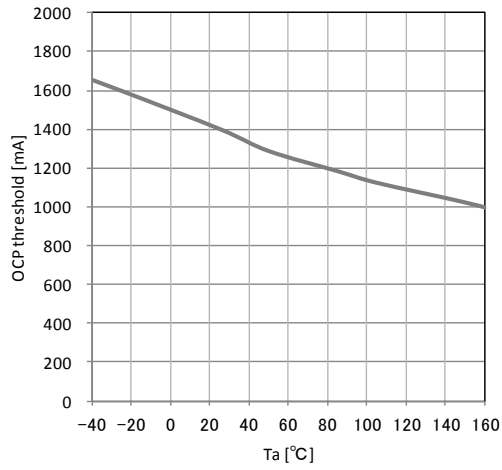

Figure 16. OCP threshold- Temperature

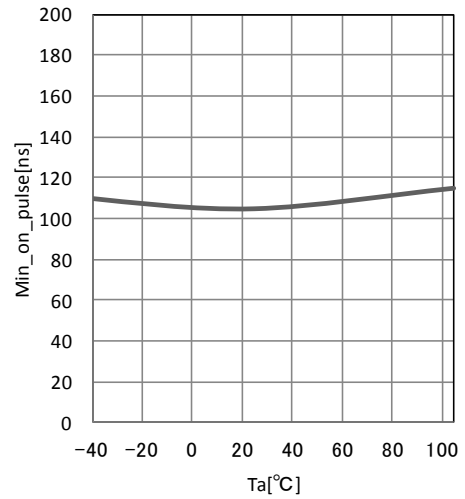

Figure 17. Min ON Time - Temperature

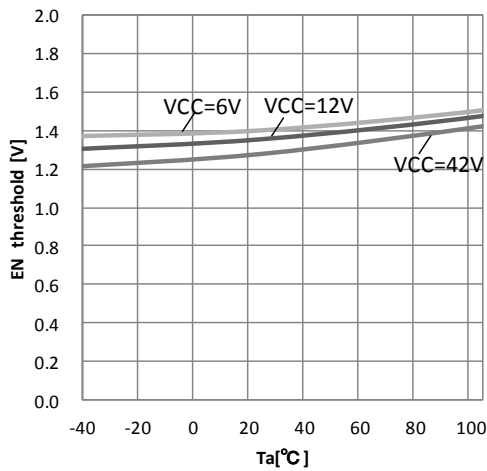

Figure 18. EN Threshold Voltage - Temperature

Reference Characteristics of typical Application Circuits

1. VOUT=5V, IOUT=0.5A

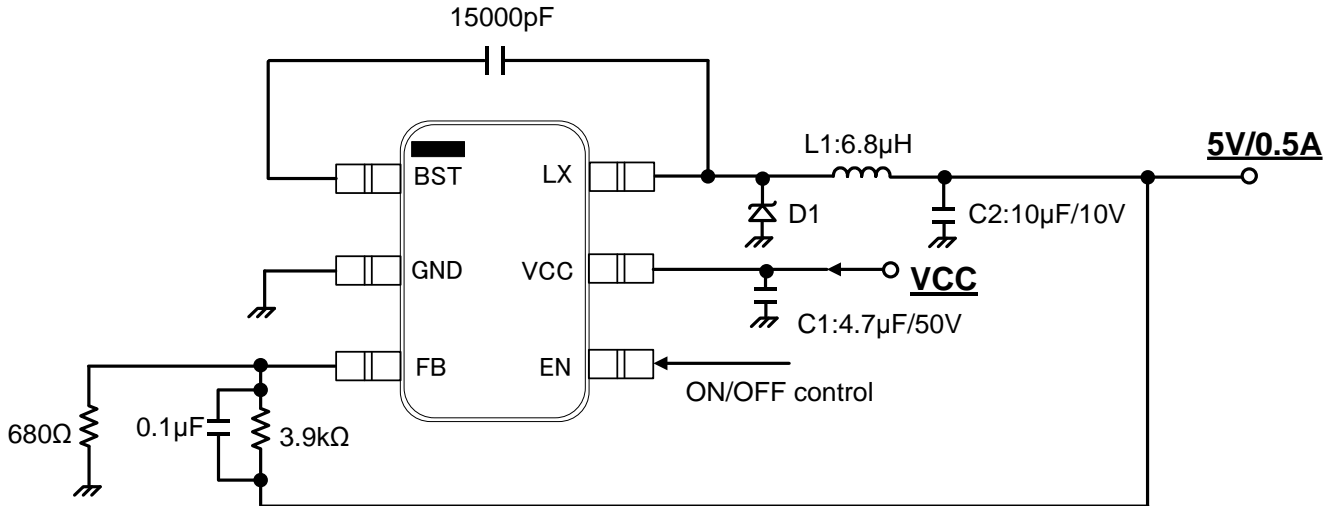

Figure 19. Typical Application Circuit (VOUT=5V)

Parts	L1	DEM4518C 1235AS-H-6R8M	6.8µH	
	TAIYO YUDEN	NR4018T680M	6.8µH	
	C1	Murata	GRM32EB31H475KA87	4.7µF/50V
	C2	Murata	GRM31CB11A106KA01	10µF/10V
	D1	Rohm	RB060M-60	

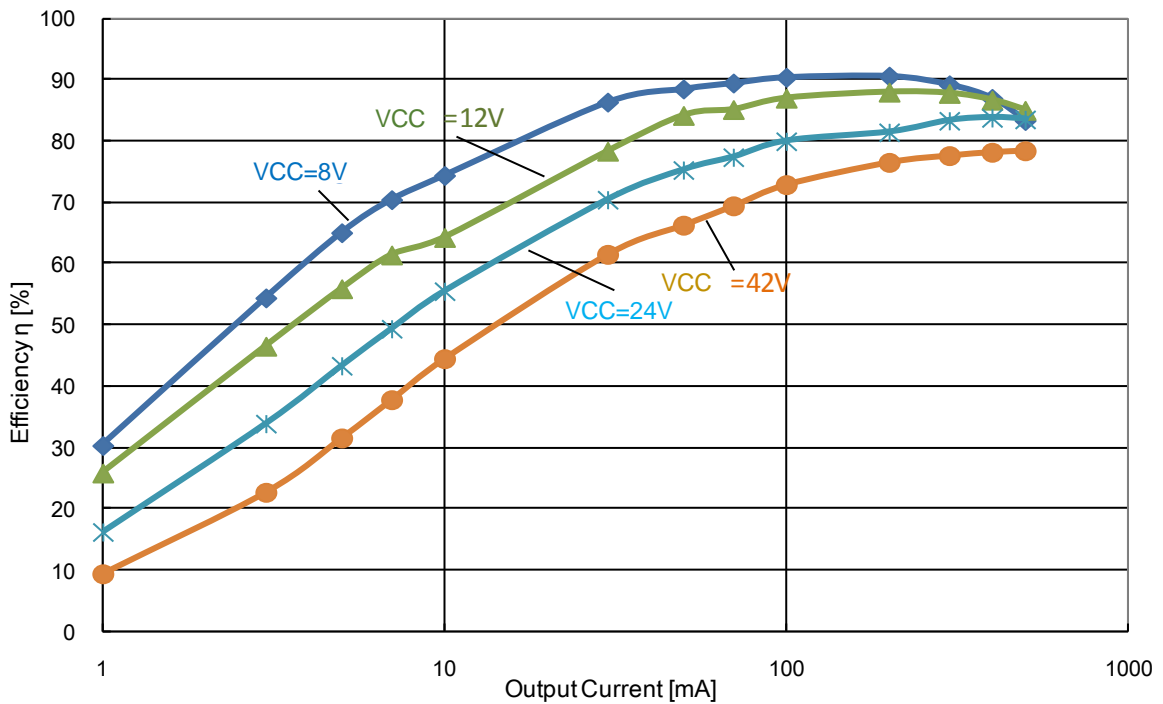

Figure 20. Power Conversion Efficiency - Output Current VOUT=5V

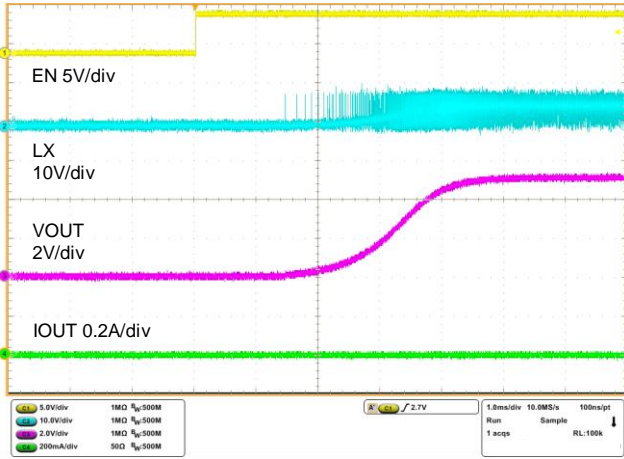

Figure 21. Start-up Characteristics
VCC=8V, IOUT=0mA, VOUT=5V

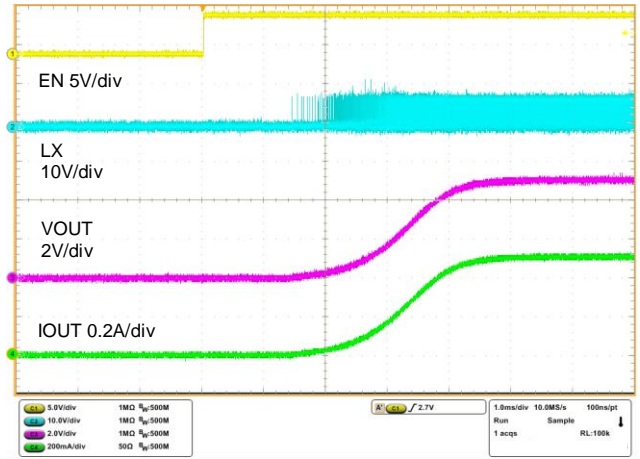

Figure 22. Start-up Characteristics
VCC=8V, IOUT=500mA, VOUT=5V

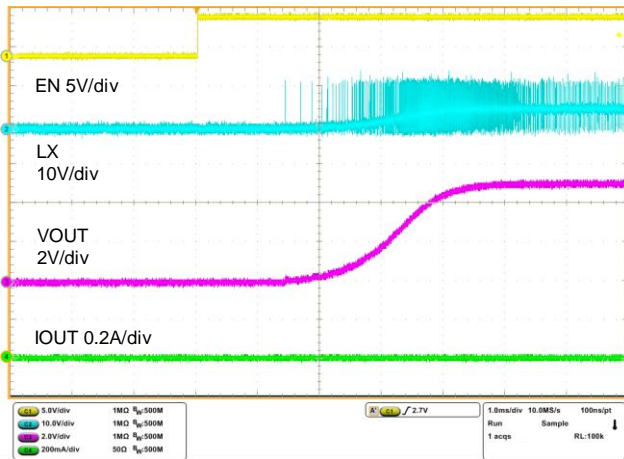

Figure 23. Start-up Characteristics
VCC=12V, IOUT=0mA, VOUT=5V

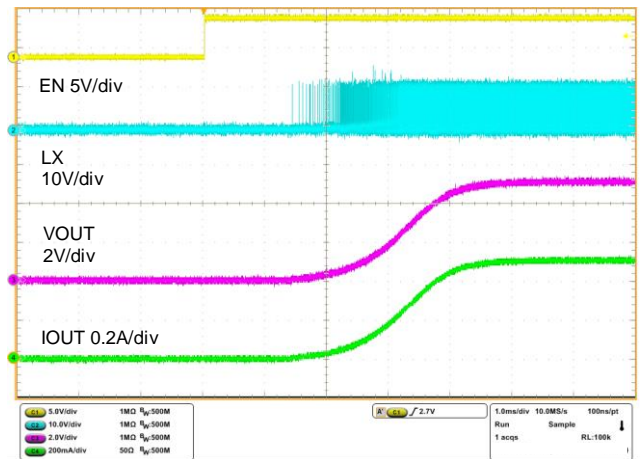

Figure 24. Start-up Characteristics
VCC=12V, IOUT=500mA, VOUT=5V

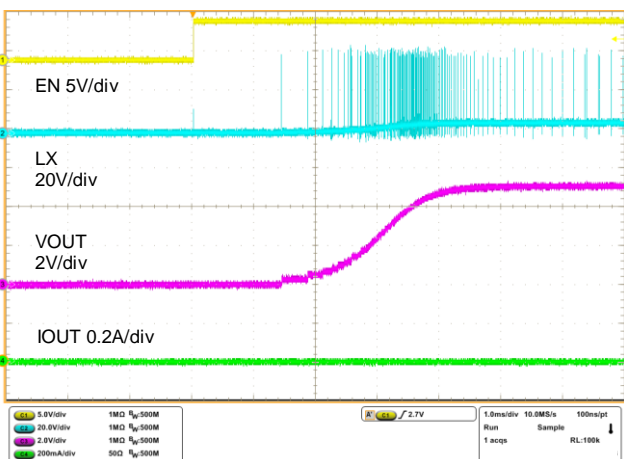

Figure 25. Start-up Characteristics
VCC=42V, IOUT=0mA, VOUT=5V

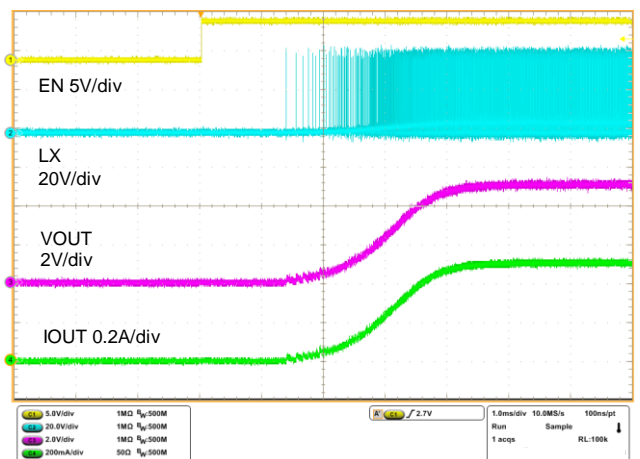

Figure 26. Start-up Characteristics
VCC=42V, IOUT=500mA, VOUT=5V

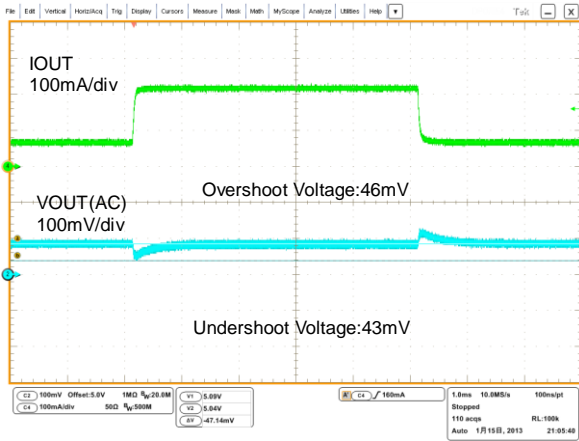

Figure 27. Load Response
IOUT=50mA<->200mA, VOUT=5V

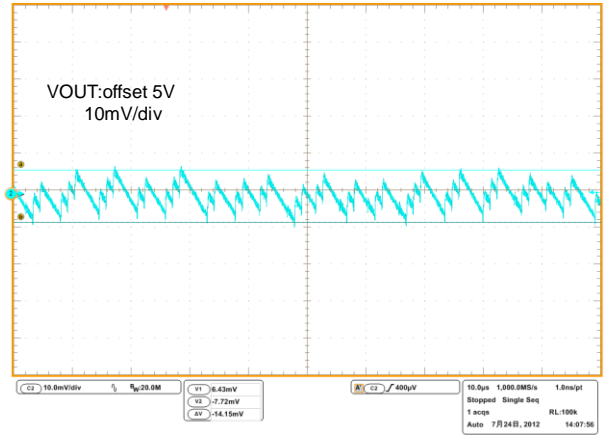

Figure 28. VOUT Ripple
IOUT=20mA, VOUT=5V

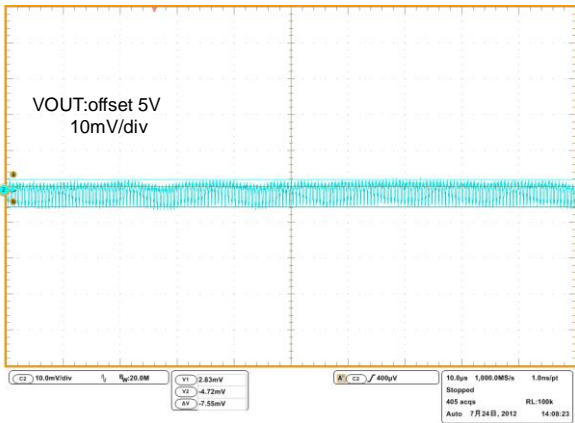

Figure 29. VOUT Ripple
IOUT=200mA, VOUT=5V

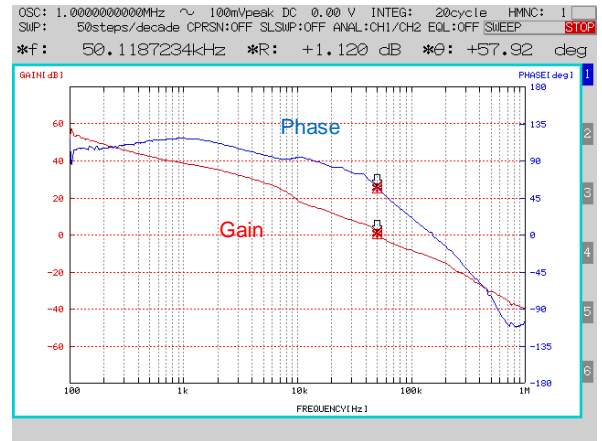

Figure 30. Frequency Response
IOUT=100mA, VOUT=5V

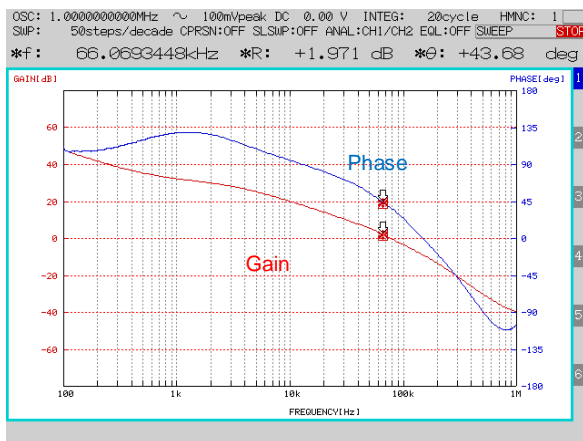

Figure 31. Frequency Response
IOUT=500mA, VOUT=5V

2. VOUT=12V, IOUT=0.5A

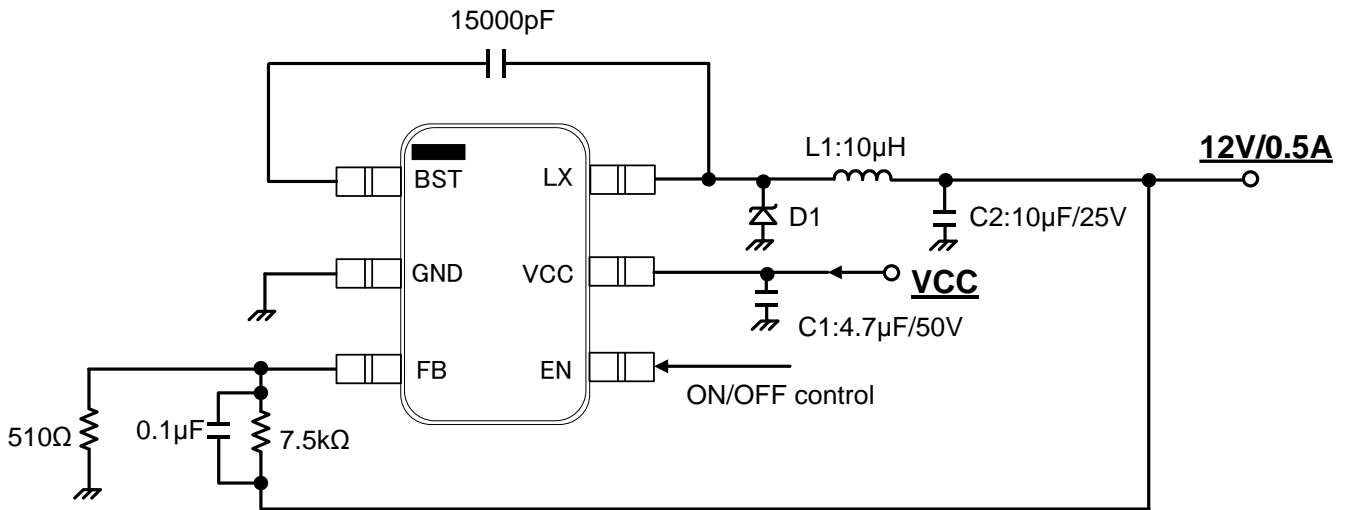
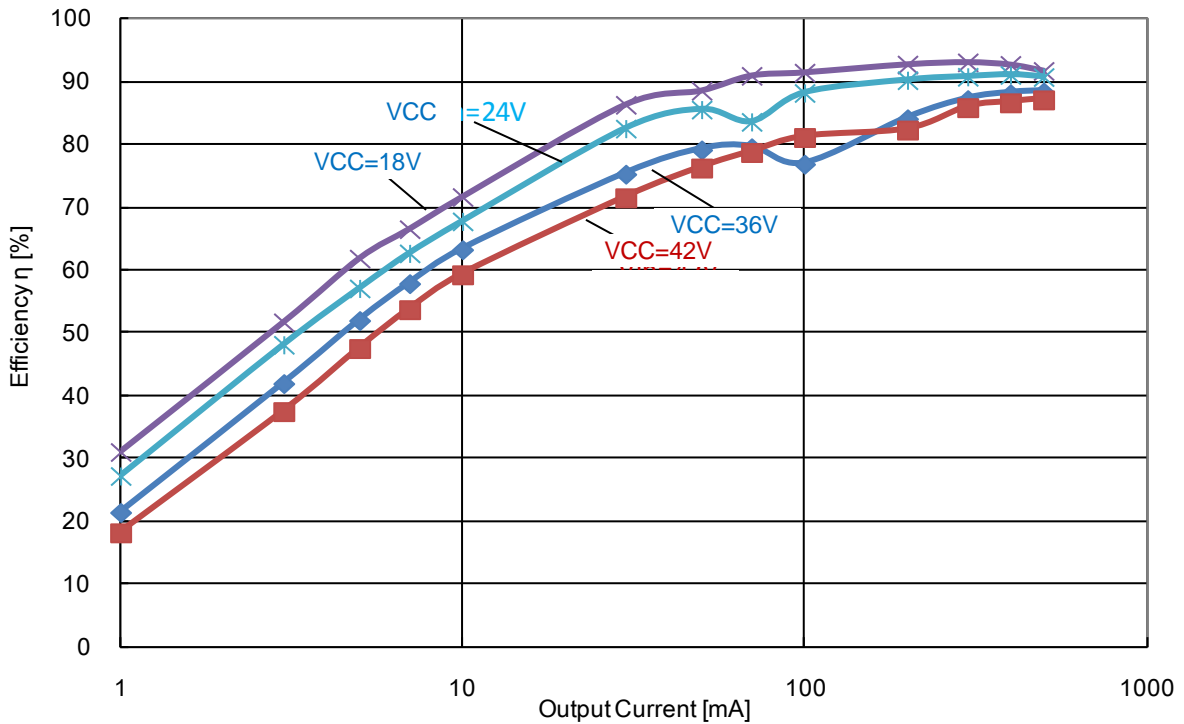

Figure 32. Typical Application Circuit (VOUT=12V)

Parts	L1	TOKO TAIYO YUDEN	DEM4518C 1235AS-H-100M NR4018T100M	10μH 10μH
	C1	Murata	GRM32EB31H475KA87	4.7μF/50V
	C2	Murata	GRM319B31E106KA12	10μF/25V
	D1	Rohm	RB060M-60	



*The efficiency falls when the switching waveform is turning from intermittent mode to continuous mode

Figure 33. Power Conversion Efficiency - Output Current VOUT=12V

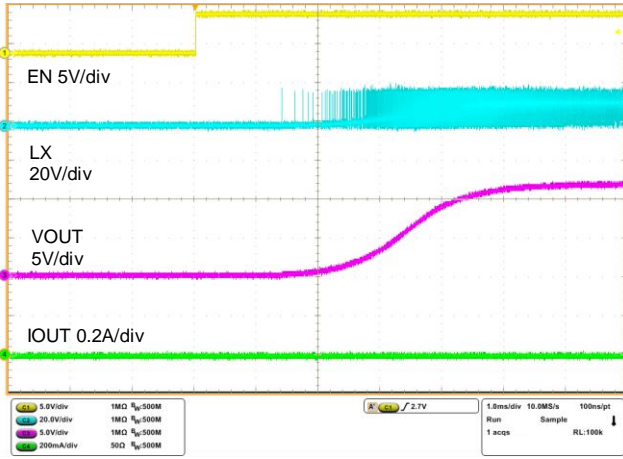

Figure 34. Start-up Characteristics
VCC=18V, IOUT=0mA, VOUT=12V

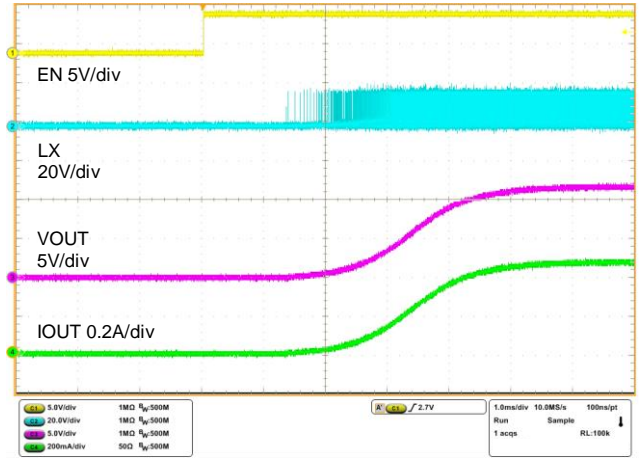

Figure 35. Start-up Characteristics
VCC=18V, IOUT=500mA, VOUT=12V

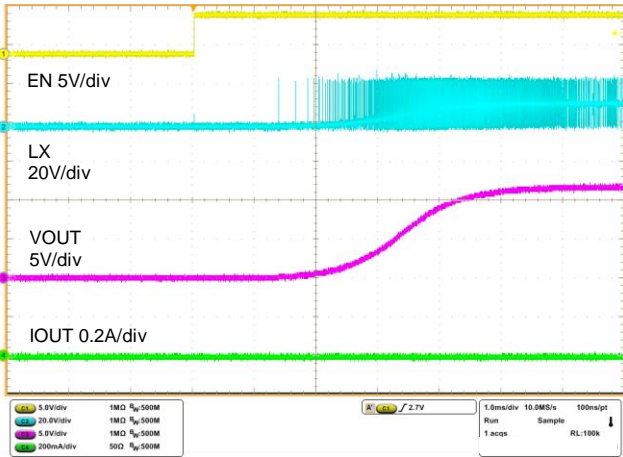

Figure 36. Start-up Characteristics
VCC=24V, IOUT=0mA, VOUT=12V

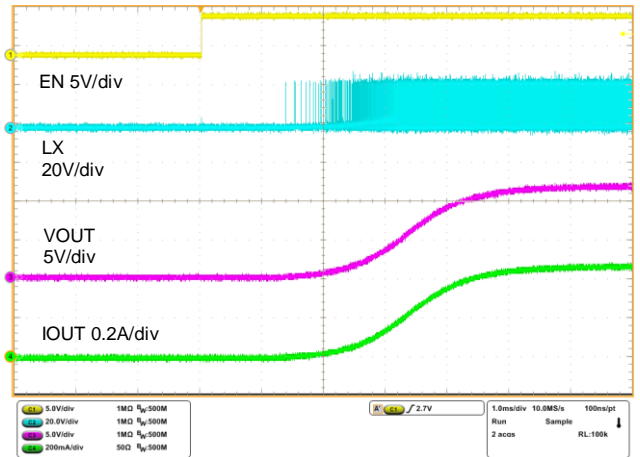

Figure 37. Start-up Characteristics
VCC=24V, IOUT=500mA, VOUT=12V

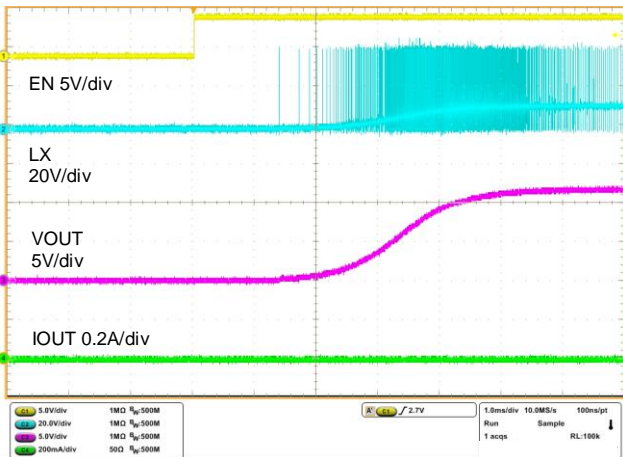

Figure 38. Start-up Characteristics
VCC=42V, IOUT=0mA, VOUT=12V

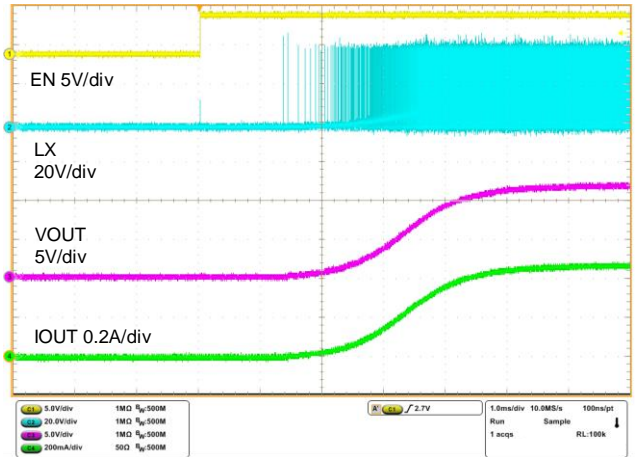

Figure 39. Start-up Characteristics
VCC=42V, IOUT=500mA, VOUT=12V

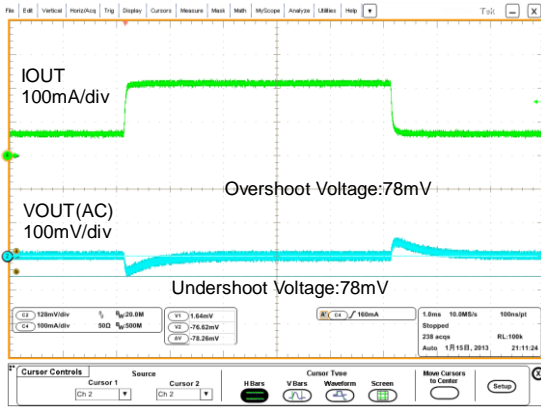

Figure 40. Load Response
IOUT=50mA<->200mA, VOUT=12V

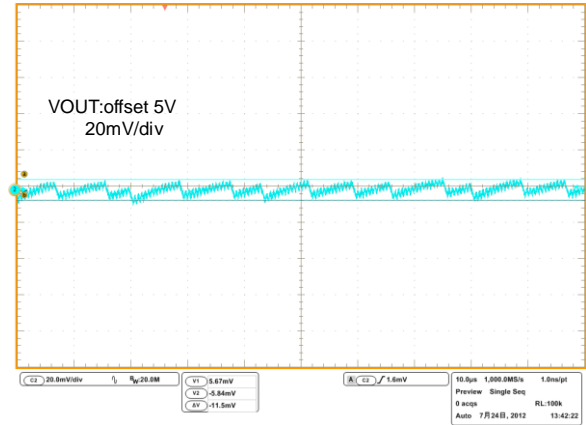

Figure 41. VOUT Ripple
IOUT=50mA, VOUT=12V

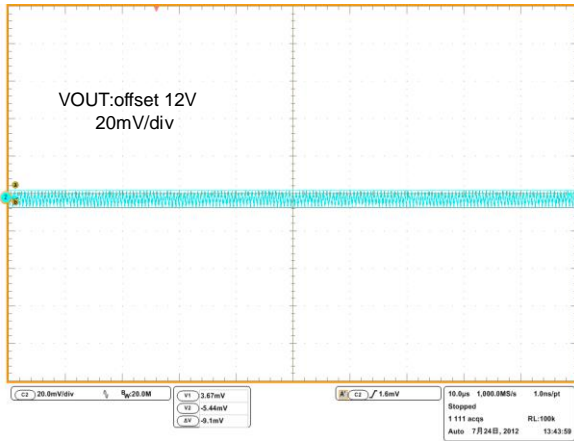

Figure 42. VOUT Ripple
IOUT=200mA, VOUT=12V

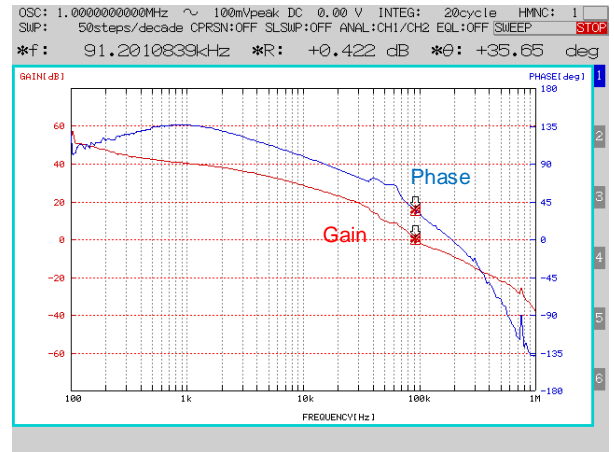

Figure 43. Frequency Response
IOUT=100mA, VOUT=12V

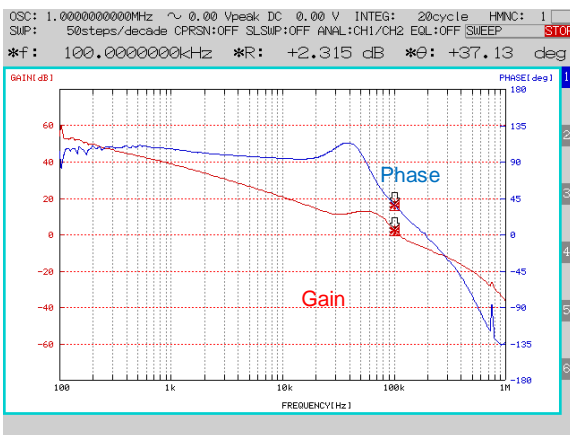
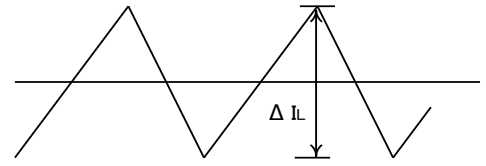

Figure 44. Frequency Response
IOUT=500mA, VOUT=12V

Application Components Selection Method

(1) Inductors

Something of the shield type that fulfills the current rating (Current value I_{peak} below), with low DCR (Direct-Current Resistance component) is recommended. Value of Inductance influences Inductor Ripple Current and becomes the cause of Output Ripple. In the same way as the formula below, this Ripple Current can be made small for as big as the L value of inductor or as high as the Switching Frequency.



$$I_{peak} = I_{OUT} + \Delta I_L / 2 \text{ [A]} \tag{4}$$

$$\Delta I_L = \frac{V_{CC} - V_{OUT}}{L} \times \frac{V_{OUT}}{V_{CC}} \times \frac{1}{f} \text{ [A]} \tag{5}$$

(ΔIL: Output Ripple Current, f: Switching Frequency)

In the BD9G101G, it is recommended the below series of 4.7μH to 15μH inductance value.

Recommended Inductor TOKO DE4518C Series
 TAIYO YUDEN NR4018 Series

Figure 45. Inductor Current

(2) Input Capacitor

In order to reduce input ripple, mount ceramic capacitor of low ESR near the VCC pin. In the BD9G101G, it is recommended the 4.7μF or more capacitor value. In case of using the electrolytic capacitor, mount about 1μF ceramic capacitor in parallel in order to prevent oscillation

(3) Output Capacitor

In order for capacitor to be used in output to reduce output ripple, ceramic capacitor of low ESR is recommended. Also, for capacitor rating, on top of putting into consideration DC Bias characteristics, please use something whose maximum rating has sufficient margin with respect to the Output Voltage. Output ripple voltage is calculated for using the following formula.

$$V_{pp} = \Delta I_L \times \frac{1}{2\pi \times f \times C_O} + \Delta I_L \times R_{ESR} \text{ [V]} \tag{6}$$

Please design in a way that it is held within Capacity Ripple Voltage. In the BD9G101G, it is recommended a ceramic capacitor 10μF or more.

(4) Output voltage setting

The internal reference voltage of error-amplifier is 0.75V. Output voltage is determined like formula (7).

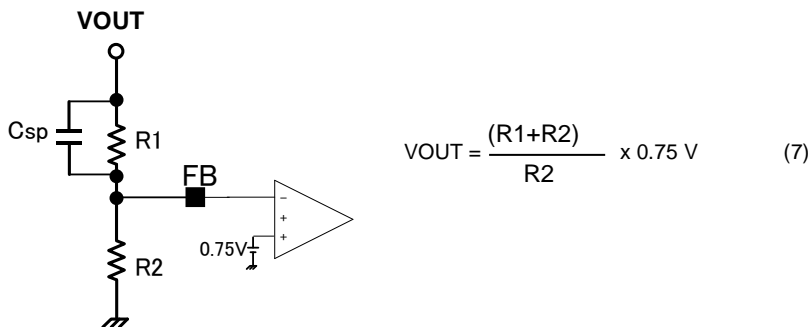

Figure 46. Voltage feedback resistance setting

However, in order to avoid the BST-UVLO operation at the time of a reduced power and light load, please set up R1+R2 is satisfied the following formulas.

$$R1 + R2 \leq V_{OUT} \times 10^3 \dots (8)$$

(5) Feed-forward capacitor Csp

Please mount feed-forward capacitor in parallel to output resistance R1.

In order that a feed-forward capacitor adjust the loop characteristic by adding the pair of a pole and zero to the loop characteristic. Therefore, a phase margin is improved and then transient response speed is improved.

The feed-forward capacitor Csp should use the value near the following formulas.

$$C_{sp} = \frac{4.7k}{R1} \times 0.15 \quad [\mu F] \quad \cdot \cdot \cdot (9)$$

(6) Bootstrap Capacitor

Please connect ceramic capacitor of 15000pF between BST Pin and LX Pin to prevent a malfunction of the internal circuit of the BST pin.

(7) Diode

Select suitable schottky diode for strength voltage and input current.

Cautions on PCB layout

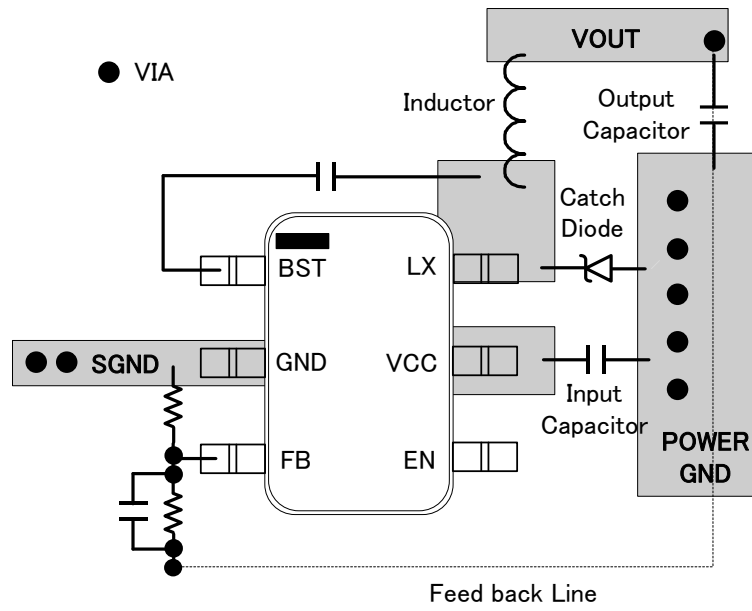

Figure 47. Reference PCB layout

Layout is a critical portion of good power supply design. There are several signals paths that conduct switching of high current or switching node of high slew rate that can interact with leakage flux or parasitic capacitance to generate noise or degrade the power supplies performance. To help reduce these problems, it should locate a low ESR ceramic capacitor as bypass capacitor near the VCC pin. Also, high current is flowed generated loop by bypass capacitor, PCB pattern of anode of catch diode. Care should be taken to minimize the current loop.

In the BD9G101G, to avoid the high frequency wave noise of high current loop, it is not connected the GND pin at the top layer and it is connected the GND pin at common line of bottom layer like Figure 47. Bypass capacitor of input, catch diode and inductor should be located as close to the IC as possible.

Power Dissipation

Figure 48 shows reducing characteristics of power dissipation measured with mount 70mm x 70mm x 1.6mm, 1layer PCB. Junction temperature must be designed not to exceed 150°C and it should have margin design. In actual use, it has difference of power dissipation and temperature increase by another heat source. Please examine it enough.

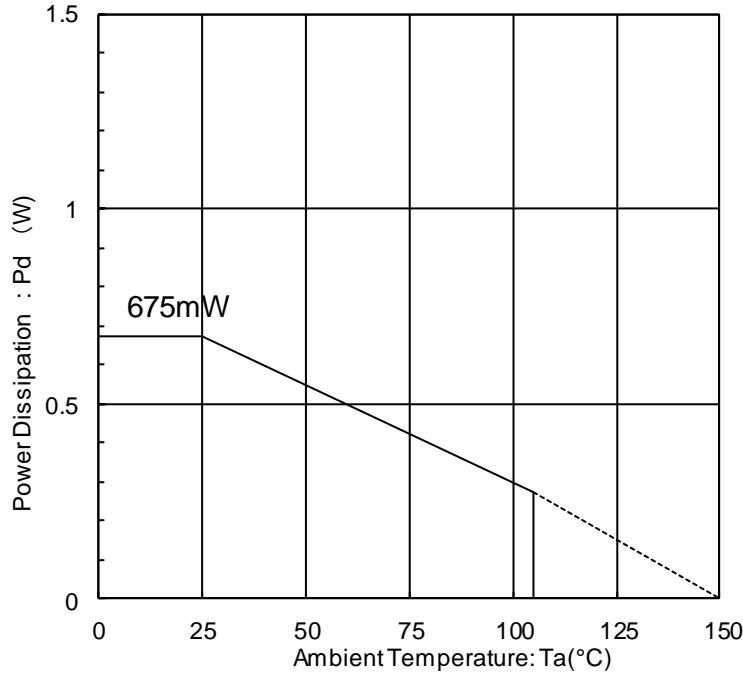

Figure 48. Power Dissipation (70mm x 70mm x 1.6mm 1layer PCB)

Power Dissipation Estimate

The following formulas show how to estimate the device power dissipation under continuous mode operations. Do not use these formulas, if the device is working in the discontinuous conduction mode.

The device power dissipation includes:

- 1) Conduction loss : $P_{con} = I_{OUT}^2 \times R_{onH} \times V_{OUT}/V_{CC}$
- 2) Switching loss : $P_{sw} = 2.5 \times 10^{-9} \times V_{CC} \times I_{OUT} \times f_{sw}$
- 3) Gate charge loss : $P_{gc} = 4.88 \times 10^{-9} \times f_{sw}$
- 4) Current loss at non switching : $P_q = 0.8 \times 10^{-3} \times V_{CC}$

Where:

I_{OUT} is the output current (A), R_{onH} is the on-resistance of the high-side Nch-FET(Ω), V_{OUT} is the output voltage (V). V_{CC} is the input voltage (V), f_{sw} is the switching frequency (Hz).

Therefore

Power dissipation of IC (P_d) is the sum of above dissipation.

$$P_d = P_{con} + P_{sw} + P_{gc} + P_q$$

The junction temperature is as follows.

$$T_j = T_a + \theta_{ja} \times P_d$$

Where:

T_a is the ambient temperature (°C)

T_j is the junction temperature (°C), θ_{ja} is the thermal resistance of the package (°C)

Please design thermal design with enough margin so that the junction temperature is not beyond maximum $T_{j_max}=150^\circ\text{C}$.

Operational Notes

1. Reverse Connection of Power Supply

Connecting the power supply in reverse polarity can damage the IC. Take precautions against reverse polarity when connecting the power supply, such as mounting an external diode between the power supply and the IC's power supply pins.

2. Power Supply Lines

Design the PCB layout pattern to provide low impedance supply lines. Furthermore, connect a capacitor to ground at all power supply pins. Consider the effect of temperature and aging on the capacitance value when using electrolytic capacitors.

3. Ground Voltage

Ensure that no pins are at a voltage below that of the ground pin at any time, even during transient condition.

4. Ground Wiring Pattern

When using both small-signal and large-current ground traces, the two ground traces should be routed separately but connected to a single ground at the reference point of the application board to avoid fluctuations in the small-signal ground caused by large currents. Also ensure that the ground traces of external components do not cause variations on the ground voltage. The ground lines must be as short and thick as possible to reduce line impedance.

5. Recommended Operating Conditions

The function and operation of the IC are guaranteed within the range specified by the recommended operating conditions. The characteristic values are guaranteed only under the conditions of each item specified by the electrical characteristics.

6. Inrush Current

When power is first supplied to the IC, it is possible that the internal logic may be unstable and inrush current may flow instantaneously due to the internal powering sequence and delays, especially if the IC has more than one power supply. Therefore, give special consideration to power coupling capacitance, power wiring, width of ground wiring, and routing of connections.

7. Testing on Application Boards

When testing the IC on an application board, connecting a capacitor directly to a low-impedance output pin may subject the IC to stress. Always discharge capacitors completely after each process or step. The IC's power supply should always be turned off completely before connecting or removing it from the test setup during the inspection process. To prevent damage from static discharge, ground the IC during assembly and use similar precautions during transport and storage.

8. Inter-pin Short and Mounting Errors

Ensure that the direction and position are correct when mounting the IC on the PCB. Incorrect mounting may result in damaging the IC. Avoid nearby pins being shorted to each other especially to ground, power supply and output pin. Inter-pin shorts could be due to many reasons such as metal particles, water droplets (in very humid environment) and unintentional solder bridge deposited in between pins during assembly to name a few.

9. Unused Input Pins

Input pins of an IC are often connected to the gate of a MOS transistor. The gate has extremely high impedance and extremely low capacitance. If left unconnected, the electric field from the outside can easily charge it. The small charge acquired in this way is enough to produce a significant effect on the conduction through the transistor and cause unexpected operation of the IC. So unless otherwise specified, unused input pins should be connected to the power supply or ground line.

Operational Notes – continued

10. Regarding the Input Pin of the IC

This monolithic IC contains P+ isolation and P substrate layers between adjacent elements in order to keep them isolated. P-N junctions are formed at the intersection of the P layers with the N layers of other elements, creating a parasitic diode or transistor. For example (refer to figure below):

When $GND > Pin A$ and $GND > Pin B$, the P-N junction operates as a parasitic diode.

When $GND > Pin B$, the P-N junction operates as a parasitic transistor.

Parasitic diodes inevitably occur in the structure of the IC. The operation of parasitic diodes can result in mutual interference among circuits, operational faults, or physical damage. Therefore, conditions that cause these diodes to operate, such as applying a voltage lower than the GND voltage to an input pin (and thus to the P substrate) should be avoided.

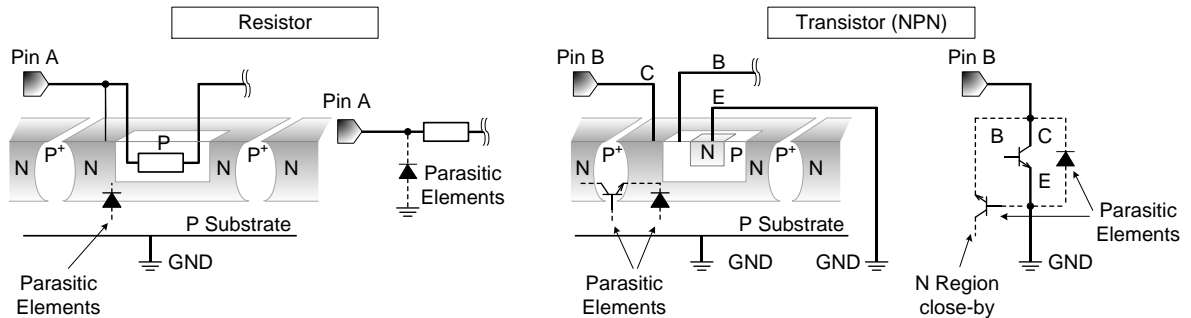

Figure50. Example of monolithic IC structure

11. Ceramic Capacitor

When using a ceramic capacitor, determine a capacitance value considering the change of capacitance with temperature and the decrease in nominal capacitance due to DC bias and others.

12. Thermal Shutdown Circuit(TSD)

This IC has a built-in thermal shutdown circuit that prevents heat damage to the IC. Normal operation should always be within the IC's maximum junction temperature rating. If however the rating is exceeded for a continued period, the junction temperature (T_j) will rise which will activate the TSD circuit that will turn OFF power output pins. When the T_j falls below the TSD threshold, the circuits are automatically restored to normal operation.

Note that the TSD circuit operates in a situation that exceeds the absolute maximum ratings and therefore, under no circumstances, should the TSD circuit be used in a set design or for any purpose other than protecting the IC from heat damage.

13. Over Current Protection Circuit (OCP)

This IC incorporates an integrated overcurrent protection circuit that is activated when the load is shorted. This protection circuit is effective in preventing damage due to sudden and unexpected incidents. However, the IC should not be used in applications characterized by continuous operation or transitioning of the protection circuit.

Ordering part number

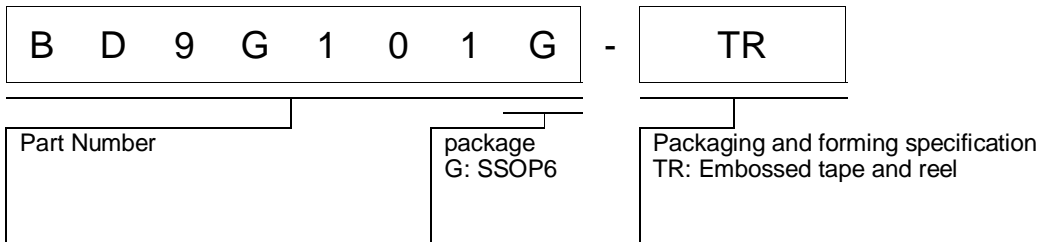

Marking Diagram

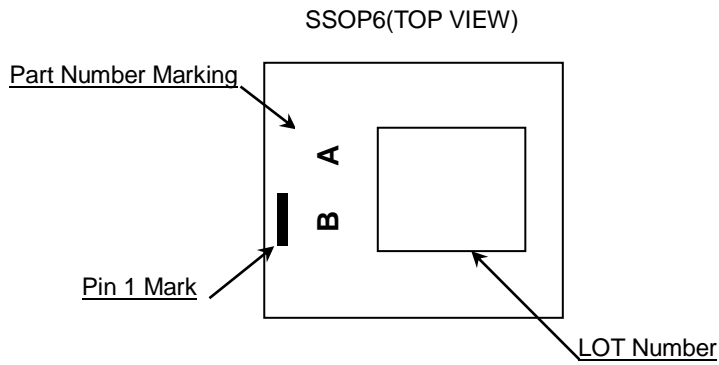

Physical Dimension and Packing Information

Package Name	SSOP6
--------------	-------

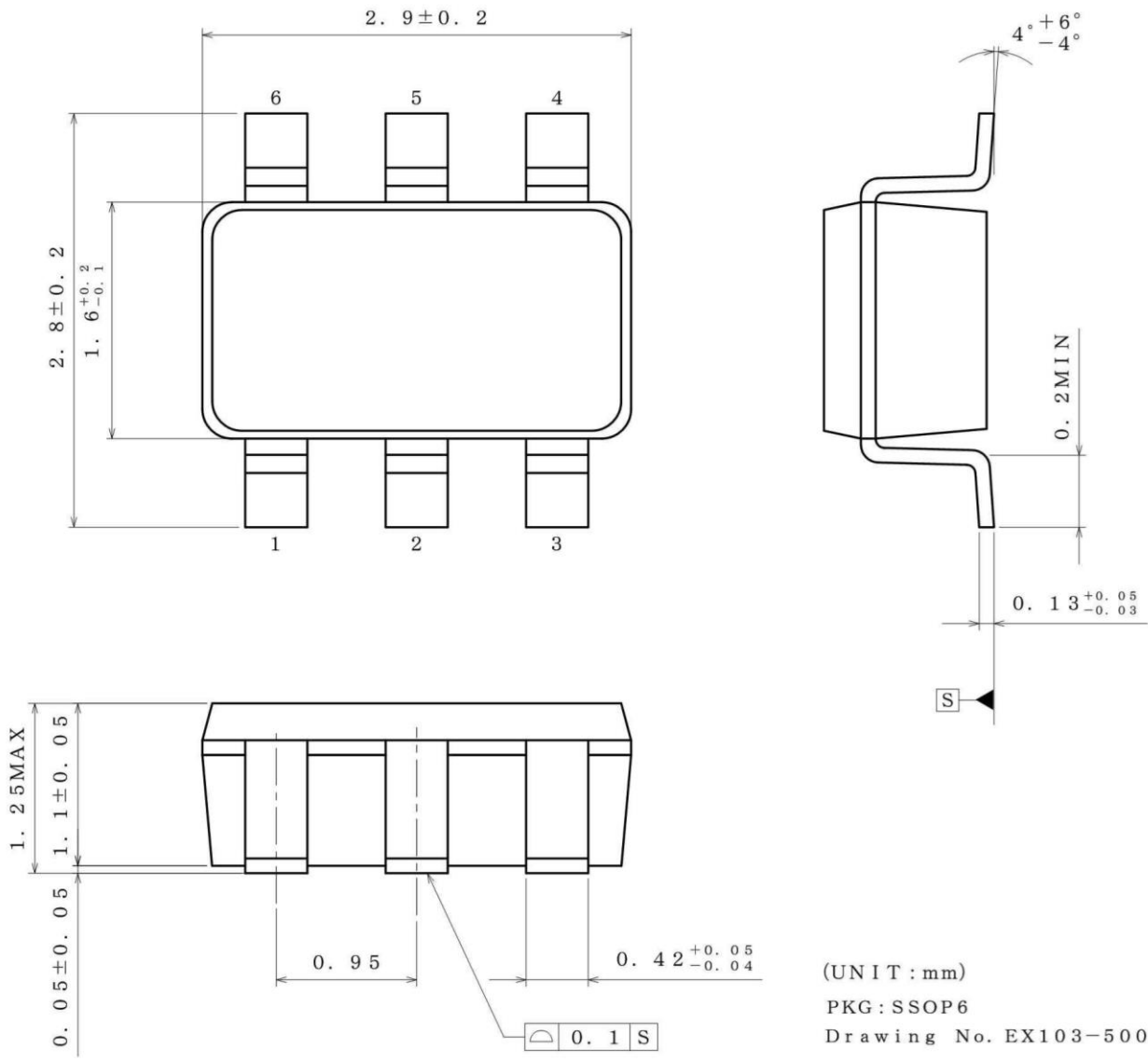

<Tape and Reel information>

Tape	Embossed carrier tape
Quantity	3000pcs
Direction of feed	TR (The direction is the 1pin of product is at the upper right when you hold reel on the left hand and you pull out the tape on the right hand)

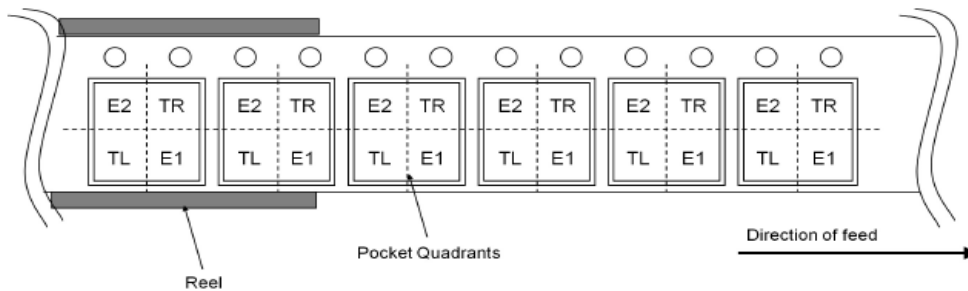

Revision History

Date	Revision	Changes
21.Aug.2012	001	New Release
04.Feb.2013	002	5~6 page : Adding of output voltage range 1, 10, 13 page : Change of typical application circuit 12, 15 page : Change of typical performance characteristic
22.Mar.2013	003	16 page : Added description of input capacitor
04.Mar.2014	004	10, 13page : Correction of application parts
13.Jan.2015	005	19 page : Correction of erroneous power dissipation estimate
16.Feb.2015	006	23 page : Correction of ordering part number format
26.Jun.2017	007	17 page : Correction of erroneous feed-forward capacitor formula
11.Dec.2018	008	1 page : Deletion of car application in use application 11, 14 page : Correction of characteristics in typical application Review sentences over all pages

Notice

Precaution on using ROHM Products

1. If you intend to use our Products in devices requiring extremely high reliability (such as medical equipment ^(Note 1), aircraft/spacecraft, nuclear power controllers, etc.) and whose malfunction or failure may cause loss of human life, bodily injury or serious damage to property ("Specific Applications"), please consult with the ROHM sales representative in advance. Unless otherwise agreed in writing by ROHM in advance, ROHM shall not be in any way responsible or liable for any damages, expenses or losses incurred by you or third parties arising from the use of any ROHM's Products for Specific Applications.

(Note1) Medical Equipment Classification of the Specific Applications

JAPAN	USA	EU	CHINA
CLASS III	CLASS III	CLASS II b	CLASS III
CLASS IV		CLASS III	

2. ROHM designs and manufactures its Products subject to strict quality control system. However, semiconductor products can fail or malfunction at a certain rate. Please be sure to implement, at your own responsibilities, adequate safety measures including but not limited to fail-safe design against the physical injury, damage to any property, which a failure or malfunction of our Products may cause. The following are examples of safety measures:
 - [a] Installation of protection circuits or other protective devices to improve system safety
 - [b] Installation of redundant circuits to reduce the impact of single or multiple circuit failure
3. Our Products are not designed under any special or extraordinary environments or conditions, as exemplified below. Accordingly, ROHM shall not be in any way responsible or liable for any damages, expenses or losses arising from the use of any ROHM's Products under any special or extraordinary environments or conditions. If you intend to use our Products under any special or extraordinary environments or conditions (as exemplified below), your independent verification and confirmation of product performance, reliability, etc. prior to use, must be necessary:
 - [a] Use of our Products in any types of liquid, including water, oils, chemicals, and organic solvents
 - [b] Use of our Products outdoors or in places where the Products are exposed to direct sunlight or dust
 - [c] Use of our Products in places where the Products are exposed to sea wind or corrosive gases, including Cl₂, H₂S, NH₃, SO₂, and NO₂
 - [d] Use of our Products in places where the Products are exposed to static electricity or electromagnetic waves
 - [e] Use of our Products in proximity to heat-producing components, plastic cords, or other flammable items
 - [f] Sealing or coating our Products with resin or other coating materials
 - [g] Use of our Products without cleaning residue of flux (Exclude cases where no-clean type fluxes is used. However, recommend sufficiently about the residue.); or Washing our Products by using water or water-soluble cleaning agents for cleaning residue after soldering
 - [h] Use of the Products in places subject to dew condensation
4. The Products are not subject to radiation-proof design.
5. Please verify and confirm characteristics of the final or mounted products in using the Products.
6. In particular, if a transient load (a large amount of load applied in a short period of time, such as pulse, is applied, confirmation of performance characteristics after on-board mounting is strongly recommended. Avoid applying power exceeding normal rated power; exceeding the power rating under steady-state loading condition may negatively affect product performance and reliability.
7. De-rate Power Dissipation depending on ambient temperature. When used in sealed area, confirm that it is the use in the range that does not exceed the maximum junction temperature.
8. Confirm that operation temperature is within the specified range described in the product specification.
9. ROHM shall not be in any way responsible or liable for failure induced under deviant condition from what is defined in this document.

Precaution for Mounting / Circuit board design

1. When a highly active halogenous (chlorine, bromine, etc.) flux is used, the residue of flux may negatively affect product performance and reliability.
2. In principle, the reflow soldering method must be used on a surface-mount products, the flow soldering method must be used on a through hole mount products. If the flow soldering method is preferred on a surface-mount products, please consult with the ROHM representative in advance.

For details, please refer to ROHM Mounting specification

Precautions Regarding Application Examples and External Circuits

1. If change is made to the constant of an external circuit, please allow a sufficient margin considering variations of the characteristics of the Products and external components, including transient characteristics, as well as static characteristics.
2. You agree that application notes, reference designs, and associated data and information contained in this document are presented only as guidance for Products use. Therefore, in case you use such information, you are solely responsible for it and you must exercise your own independent verification and judgment in the use of such information contained in this document. ROHM shall not be in any way responsible or liable for any damages, expenses or losses incurred by you or third parties arising from the use of such information.

Precaution for Electrostatic

This Product is electrostatic sensitive product, which may be damaged due to electrostatic discharge. Please take proper caution in your manufacturing process and storage so that voltage exceeding the Products maximum rating will not be applied to Products. Please take special care under dry condition (e.g. Grounding of human body / equipment / solder iron, isolation from charged objects, setting of Ionizer, friction prevention and temperature / humidity control).

Precaution for Storage / Transportation

1. Product performance and soldered connections may deteriorate if the Products are stored in the places where:
 - [a] the Products are exposed to sea winds or corrosive gases, including Cl₂, H₂S, NH₃, SO₂, and NO₂
 - [b] the temperature or humidity exceeds those recommended by ROHM
 - [c] the Products are exposed to direct sunshine or condensation
 - [d] the Products are exposed to high Electrostatic
2. Even under ROHM recommended storage condition, solderability of products out of recommended storage time period may be degraded. It is strongly recommended to confirm solderability before using Products of which storage time is exceeding the recommended storage time period.
3. Store / transport cartons in the correct direction, which is indicated on a carton with a symbol. Otherwise bent leads may occur due to excessive stress applied when dropping of a carton.
4. Use Products within the specified time after opening a humidity barrier bag. Baking is required before using Products of which storage time is exceeding the recommended storage time period.

Precaution for Product Label

A two-dimensional barcode printed on ROHM Products label is for ROHM's internal use only.

Precaution for Disposition

When disposing Products please dispose them properly using an authorized industry waste company.

Precaution for Foreign Exchange and Foreign Trade act

Since concerned goods might be fallen under listed items of export control prescribed by Foreign exchange and Foreign trade act, please consult with ROHM in case of export.

Precaution Regarding Intellectual Property Rights

1. All information and data including but not limited to application example contained in this document is for reference only. ROHM does not warrant that foregoing information or data will not infringe any intellectual property rights or any other rights of any third party regarding such information or data.
2. ROHM shall not have any obligations where the claims, actions or demands arising from the combination of the Products with other articles such as components, circuits, systems or external equipment (including software).
3. No license, expressly or implied, is granted hereby under any intellectual property rights or other rights of ROHM or any third parties with respect to the Products or the information contained in this document. Provided, however, that ROHM will not assert its intellectual property rights or other rights against you or your customers to the extent necessary to manufacture or sell products containing the Products, subject to the terms and conditions herein.

Other Precaution

1. This document may not be reprinted or reproduced, in whole or in part, without prior written consent of ROHM.
2. The Products may not be disassembled, converted, modified, reproduced or otherwise changed without prior written consent of ROHM.
3. In no event shall you use in any way whatsoever the Products and the related technical information contained in the Products or this document for any military purposes, including but not limited to, the development of mass-destruction weapons.
4. The proper names of companies or products described in this document are trademarks or registered trademarks of ROHM, its affiliated companies or third parties.

General Precaution

1. Before you use our Products, you are requested to carefully read this document and fully understand its contents. ROHM shall not be in any way responsible or liable for failure, malfunction or accident arising from the use of any ROHM's Products against warning, caution or note contained in this document.
2. All information contained in this document is current as of the issuing date and subject to change without any prior notice. Before purchasing or using ROHM's Products, please confirm the latest information with a ROHM sales representative.
3. The information contained in this document is provided on an "as is" basis and ROHM does not warrant that all information contained in this document is accurate and/or error-free. ROHM shall not be in any way responsible or liable for any damages, expenses or losses incurred by you or third parties resulting from inaccuracy or errors of or concerning such information.

X-ON Electronics

Largest Supplier of Electrical and Electronic Components

Click to view similar products for [Switching Voltage Regulators](#) category:

Click to view products by [ROHM](#) manufacturer:

Other Similar products are found below :

[FAN53610AUC33X](#) [FAN53611AUC123X](#) [FAN48610BUC33X](#) [FAN48610BUC45X](#) [FAN48617UC50X](#) [R3](#) [430464BB](#) [KE177614](#)
[MAX809TTR](#) [NCV891234MW50R2G](#) [NCP81103MNTXG](#) [NCP81203PMNTXG](#) [NCP81208MNTXG](#) [NCP81109GMNTXG](#)
[SCY1751FCCT1G](#) [NCP81109JMNTXG](#) [AP3409ADNTR-G1](#) [NCP81241MNTXG](#) [LTM8064IY](#) [LT8315EFE#TRPBF](#) [LTM4664EY#PBF](#)
[LTM4668AIY#PBF](#) [NCV1077CSTBT3G](#) [XCL207A123CR-G](#) [MPM54304GMN-0002](#) [MPM54304GMN-0004](#) [MPM54304GMN-0003](#)
[XDPE132G5CG000XUMA1](#) [AP62300Z6-7](#) [MP8757GL-P](#) [MIC23356YFT-TR](#) [LD8116CGL](#) [HG2269M/TR](#) [OB2269](#) [XD3526](#) [U6215A](#)
[U6215B](#) [U6620S](#) [LTC3412IFE](#) [LT1425IS](#) [MAX25203BATJA/VY+](#) [MAX77874CEWM+](#) [XC9236D08CER-G](#) [ISL95338IRTZ](#) [MP3416GJ-P](#)
[BD9S201NUX-CE2](#) [MP5461GC-Z](#) [MPQ4415AGQB-Z](#) [MPQ4590GS-Z](#) [MAX38640BENT18+T](#)