

A/D Converter Series

# Successive Approximation A/D Converter

## 10bit, 50k to 220kSPS, 2.7 to 5.25V, 8-channel, SPI™ Interface

**BH2715FV**

**General Description**

The BH2715FV is a general purpose, 10-bit 8-channel successive approximation A/D converter. The sampling rate of BH2715FV ranges from 50kSPS to 220kSPS.

**Features**

- Successive Approximation A/D Converter with a Built-in Track/Hold Circuit
- 8 Input Channels
- Separate Analog and Digital Power Supplies
- Serial Interface Compatible with SPI™/DSP™/MICROWIRE™
- Low Power Consumption
- Power Down Mode

**Key Specifications**

- Supply Voltage Range: 2.7V to 5.25V
- Resolution: 10bit
- INL: ±1.5 LSB
- DNL: ±1.2 LSB
- Sampling Rate: 220kSPS(Max)
- Power Consumption
  - In 220kSPS Operation: 1.2mW at V<sub>DD</sub>=3V(Typ)
  - 6.5mW at V<sub>DD</sub>=5V(Typ)
- Supply Current In Power Down: 0µA (Typ)
- Operational Temperature Range: -40°C to +85°C

**Package**

SSOP-B16 W(Typ) x D(Typ) x H(Max)  
5.00mm x 6.40mm x 1.35mm

**Applications**

- Sensors / Scanners
- Battery Monitors and Power Supply Monitors
- Control of the Various Types of FA Equipment



**Typical Application Circuit**

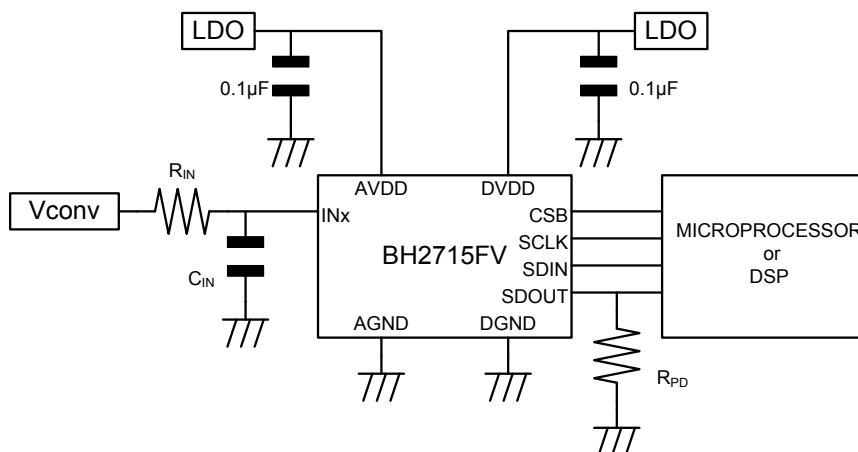

## Pin Configuration

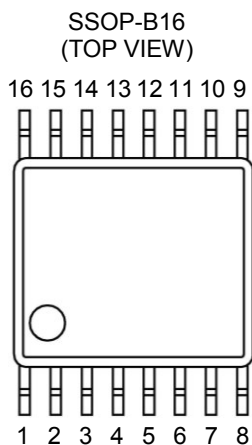

## Pin Descriptions

Pin No.	Pin Name	Description
1	CSB	Chip select input terminal. Logic input in active-low. The falling edge of CSB starts A/D conversion.
2	AVDD	Analog power supply terminal.
3	AGND	Analog ground terminal.
4	IN0	Analog input terminal. Input range : 0 to $V_A[V]$ .
5	IN1	Analog input terminal. Input range : 0 to $V_A[V]$ .
6	IN2	Analog input terminal. Input range : 0 to $V_A[V]$ .
7	IN3	Analog input terminal. Input range : 0 to $V_A[V]$ .
8	IN4	Analog input terminal. Input range : 0 to $V_A[V]$ .
9	IN5	Analog input terminal. Input range : 0 to $V_A[V]$ .
10	IN6	Analog input terminal. Input range : 0 to $V_A[V]$ .
11	IN7	Analog input terminal. Input range : 0 to $V_A[V]$ .
12	DGND	Digital ground terminal.
13	DVDD	Digital power supply terminal.
14	SDIN	Serial data input terminal to set a register.
15	SDOUT	Serial data output terminal. SDOUT outputs serial data synchronously to the falling edge of SCLK. In the 16-bit serial data, the first 4 bits are zeros, the following 10-bit data is an A/D conversion result in MSB first and the last 2 bits are zeros.
16	SCLK	Clock input terminal. Controlling serial data output and A/D conversion processing.

Block Diagram

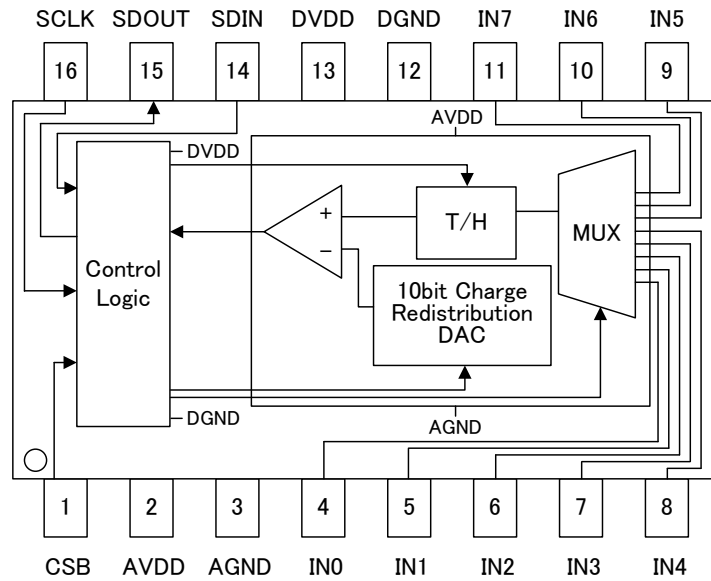

1. MUX(Analog Multiplexer)  
 MUX is a group of analog switches which connects one of the input terminals IN0 through IN7 to the Track/Hold circuit for A/D conversions. MUX is controlled by the 3-wire serial interface.
2. T/H(Track/Hold circuit)  
 Track/Hold circuit tracks the input terminal voltage before A/D conversion starts, and the input voltage is held just after the A/D conversion starts. Even if the terminal voltage changes in the A/D conversion, it is possible to convert correctly the input voltage which is captured just as the A/D conversion starts.
3. 10bit Charge-Redistribution DAC  
 The capacitor type D/A converter with the 10 bit resolution. It gives a comparison voltage for A/D conversion to the voltage comparator.

Absolute Maximum Ratings (T<sub>A</sub>=25°C)

Parameter	Symbol	Ratings	Unit
Supply Voltage	V <sub>DD</sub>	-0.3 to +6.5	V
Analog Input Voltage	V <sub>IN ANA</sub>	-0.3 to V <sub>DD</sub> +0.3 ≤ +6.5	V
Digital Input Voltage	V <sub>IN DIG</sub>	-0.3 to +6.5	V
Power Dissipation	P <sub>D</sub>	Unmounted	0.40 <sup>(Note1)</sup>
		mounted	0.70 <sup>(Note2)</sup>
Junction Temperature	T <sub>Jmax</sub>	125	°C
Storage Temperature	T <sub>stg</sub>	-55 to +125	°C

(Note 1) Derate by 4.0mW/°C when operating above T<sub>A</sub>=25°C. (Unmounted on a PCB board)

(Note 2) Derate by 7.0mW/°C when operating above T<sub>A</sub>=25°C. (when mounted on a 70mm×70mm×1.6mm, 1-layer, glass-epoxy board.)

**Caution:** Operating the IC over the absolute maximum ratings may damage the IC. The damage can either be a short circuit between pins or an open circuit between pins and the internal circuitry. Therefore, it is important to consider circuit protection measures, such as adding a fuse, in case the IC is operated over the absolute maximum ratings.

## Recommended Operational Conditions

Parameter	Symbol	Ratings	Unit
Analog Supply Voltage	V <sub>A</sub>	2.7 to 5.25	V
Digital Supply Voltage	V <sub>D</sub>	2.7 to 5.25	V
Analog Input Voltage	V <sub>IN ANA</sub>	0 to V <sub>A</sub>	V
Digital Input Voltage	V <sub>IN DIG</sub>	0 to 5.25	V
Clock Frequency	f <sub>SCLK</sub>	0.8 to 3.52	MHz
Sampling Rate	f <sub>SAMPLE</sub>	50 to 220	KSPS
Operational Temperature	T <sub>opr</sub>	-40 to +85	°C

## Electrical Characteristics

(Unless otherwise specified,  $V_{DD}=2.7$  to  $5.25V$ ,  $f_{SCLK}=0.8$  to  $3.52MHz$ ,  $f_{SAMPLE}=50$  to  $220kSPS$ ,  $C_L=10pF$ ,  $T_A=-25$  to  $+85^{\circ}C$ , Typical values are at  $V_{DD}=5V$  and  $T_A=25^{\circ}C$ )

Parameter	Symbol	Limits			Unit	Condition
		Min	Typ	Max		
<b>&lt;Static Converter Characteristics&gt;</b>						
Resolution with No missing codes	RES	10	-	-	Bits	$T_A=25^{\circ}C$
Integral Non-Linearity	INL	-1.5	-	+1.5	LSB	$T_A=25^{\circ}C$ , End point method
Differential Non-Linearity	DNL	-1.2	-	+1.2	LSB	$T_A=25^{\circ}C$
Offset Error	ZE	-1	-	+1	LSB	$T_A=25^{\circ}C$
Full Scale Error	FSE	-1	-	+1	LSB	$T_A=25^{\circ}C$
<b>&lt;Analog Input Characteristics&gt;</b>						
Input Voltage Range	$V_{IN}$	0	-	$V_A$	V	
Input DC Leakage Current	$I_{LEAK}$	-1	-	+1	$\mu A$	
Input Capacitance	$C_{INA}$	-	32	-	pF	In the Track mode
<b>&lt;Digital Input Characteristics&gt;</b>						
High Input Voltage1	$V_{IH1}$	2.1	-	-	V	$V_{DD}=2.7$ to $3.6V$
High Input Voltage2	$V_{IH2}$	2.4	-	-	V	$V_{DD}=4.75$ to $5.25V$
Low Input Voltage	$V_{IL}$	-	-	0.8	V	
Input Current	$I_{IND}$	-1	-	+1	$\mu A$	
<b>&lt;Digital Output Characteristics&gt;</b>						
Output High Voltage	$V_{OH}$	$V_D-0.5$	-	-	V	$I_L=200\mu A$
Output Low Voltage	$V_{OL}$	-	-	0.4	V	$I_L=-1.0mA$
Leakage current in the high-impedance state	$I_{OZ}$	-1	-	+1	$\mu A$	
Output Coding		Straight Binary				
<b>&lt;Power Supply Characteristics&gt;</b>						
Supply Current (Operational)	$I_{DD1}$	-	1.3	2.1	mA	$V_{DD}=5.25V$ , $V_{IN}=V_{DD}/2$ , $f_{SAMPLE}=220kSPS$
	$I_{DD2}$	-	0.4	0.94	mA	$V_{DD}=3.6V$ , $V_{IN}=V_{DD}/2$ , $f_{SAMPLE}=220kSPS$
Supply Current (Power Down)	$I_{PD1}$	-1	0	+1	$\mu A$	$V_{DD}=5.25V$ , $V_{IN}=GND$ , $f_{SAMPLE}=0SPS$ , $f_{SCLK}=0Hz$
	$I_{PD2}$	-1	0	+1	$\mu A$	$V_{DD}=5.25V$ , $V_{IN}=GND$ , $f_{SAMPLE}=0SPS$ , $f_{SCLK}=0Hz$
<b>&lt;AC characteristic&gt;</b>						
Clock Frequency	$f_{SCLK}$	0.8	-	3.52	MHz	
Sample Rate	$f_{SAMPLE}$	50	-	220	kSPS	
Conversion Time	$t_{CONVERT}$	-	13	-	SCLK	
Clock Duty Cycle	DC	40	-	60	%	
Acquisition Time	$t_{ACQ}$	-	3	-	SCLK	
Throughput Time	$t_{TP}$	-	16	-	SCLK	

## Timing Specifications

(Unless otherwise specified,  $V_{DD}=2.7$  to  $5.25V$ ,  $f_{SCLK}=0.8$  to  $3.52MHz$ ,  $f_{SAMPLE}=50$  to  $220kSPS$ ,  $C_L=10pF$ ,  $T_A=25^{\circ}C$ )

Parameter	Symbol	Limits			Unit	Condition
		Min	Typ	Max		
CSB Setup Time	$t_{CS}$	10	-	-	ns	
DOU Access Time	$t_{DACC}$	-	-	27	ns	
DIN Setup Time	$t_{DS}$	10	-	-	ns	
DIN Hold Time	$t_{DH}$	10	-	-	ns	
DOU Enable Time	$t_{EN}$	-	-	30	ns	
DOU Disable Time	$t_{DIS}$	-	-	20	ns	

Timing Chart

1. Serial Interface Timing Diagram

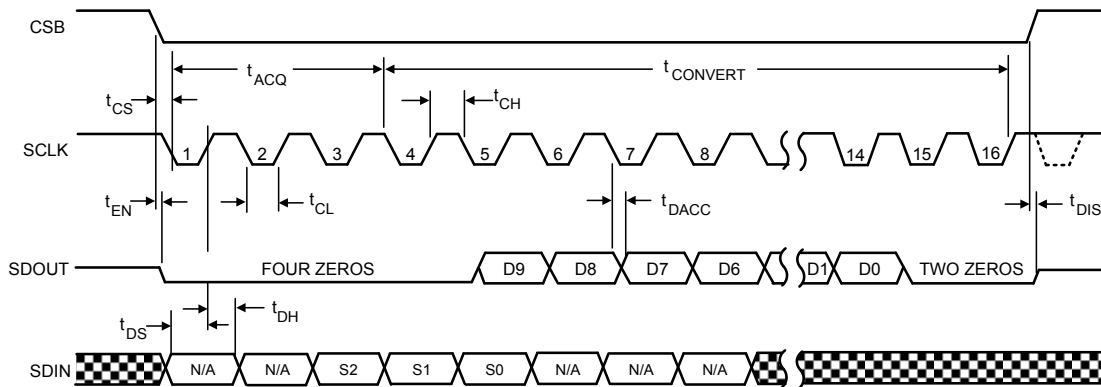

2. A/D Conversion Timing Diagram

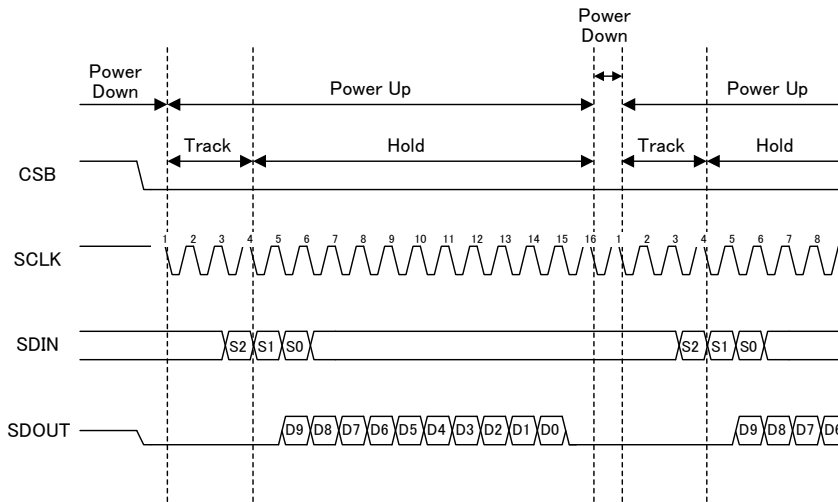

Analog Input Terminal Selection

1. Control Register

Bit7	Bit6	Bit5	Bit4	Bit3	Bit2	Bit1	Bit0
N/A	N/A	S2	S1	S0	N/A	N/A	N/A

- (1) Eight-bit data is loaded into the control register from SDIN on the first eight rising edges of SCLK after CSB falls.
- (2) A selected channel is used in the subsequent conversion.
- (3) The bits described as N/A don't affect any functions.

2. Input Channel Selection

S2	S1	S0	Input Channel
0	0	0	IN0
0	0	1	IN1
0	1	0	IN2
0	1	1	IN3
1	0	0	IN4
1	0	1	IN5
1	1	0	IN6
1	1	1	IN7

Typical Performance Characteristics

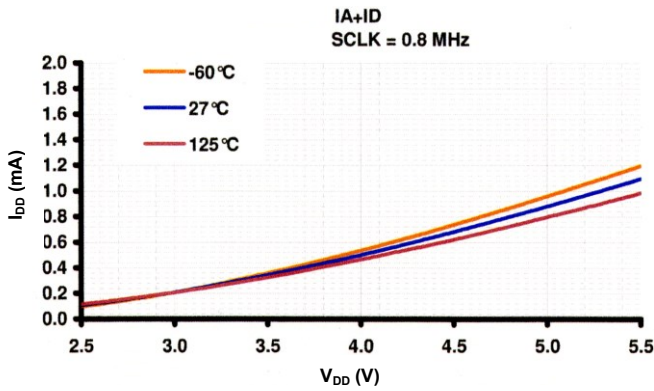

Figure 1.  $I_{DD}$  vs  $V_{DD}$  ( $f_{SCLK}=0.8MHz$ )

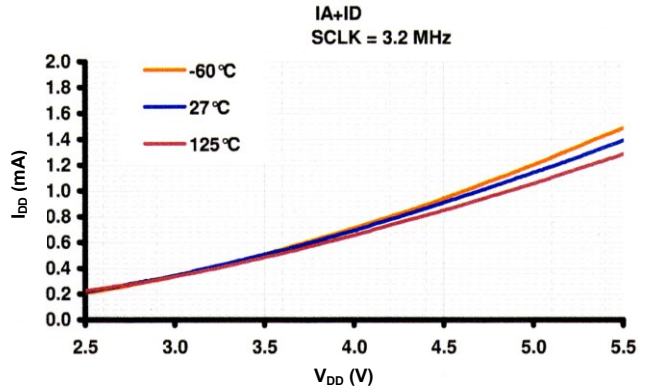

Figure 2.  $I_{DD}$  vs  $V_{DD}$  ( $f_{SCLK}=3.2MHz$ )

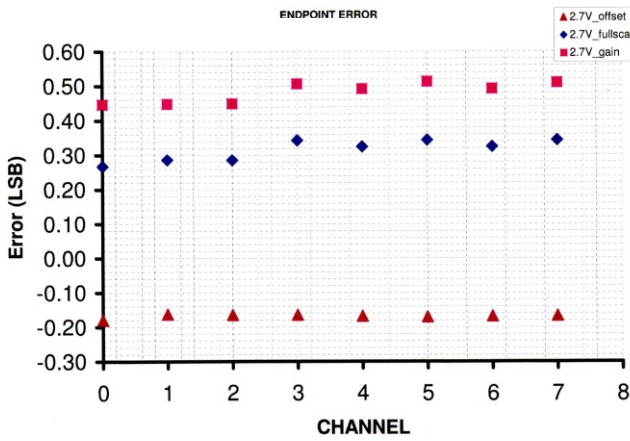

Figure 3. ENDPOINT ERROR vs CHANNEL ( $V_{DD}=2.7V$ )

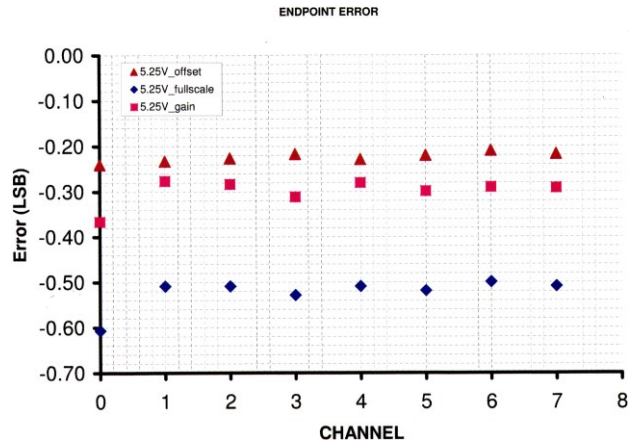

Figure 4. ENDPOINT ERROR vs CHANNEL ( $V_{DD}=5.25V$ )

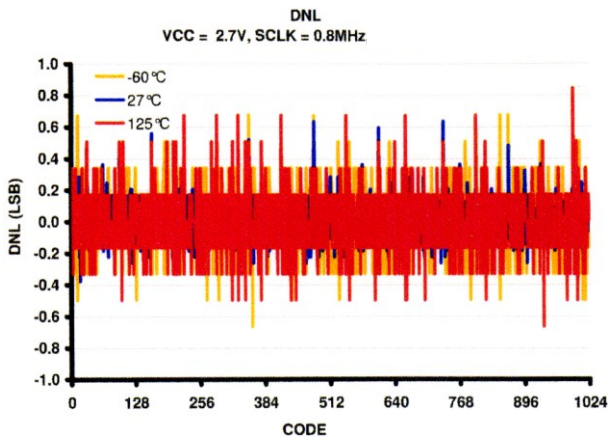

Figure 5. DNL vs OUTPUT CODE ( $V_{DD}=2.7V, f_{SCLK}=0.8MHz, f_{SAMPLE}=50kSPS$ )

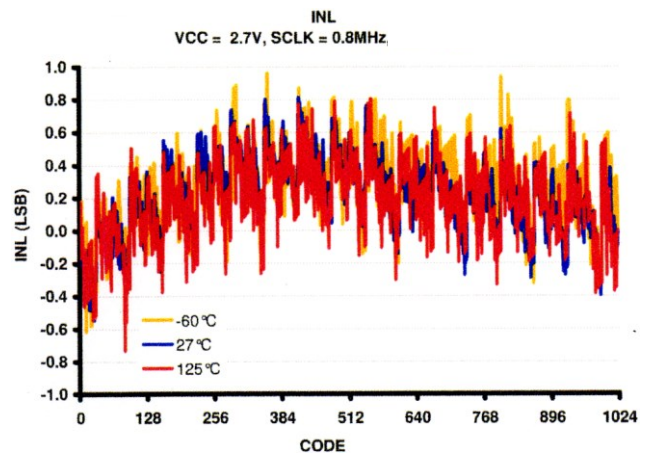

Figure 6. INL vs OUTPUT CODE ( $V_{DD}=2.7V, f_{SCLK}=0.8MHz, f_{SAMPLE}=50kSPS$ )

(\*)The data above is measurement value of typical sample, it is not guaranteed.



Typical Performance Characteristics – continued

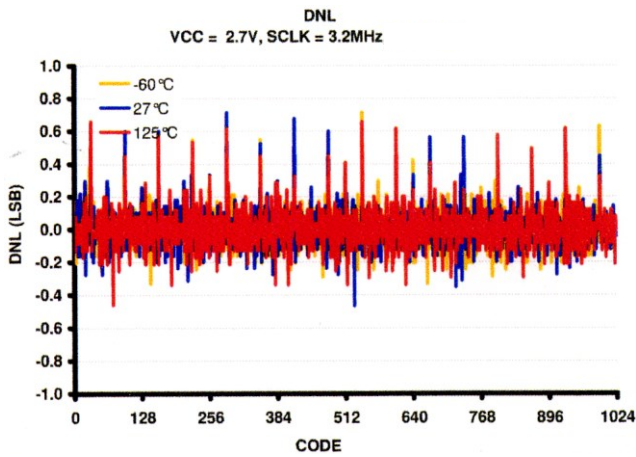

Figure 7. DNL vs OUTPUT CODE  
( $V_{DD}=2.7V$ ,  $f_{SCLK}=3.2MHz$ ,  $f_{SAMPLE}=200kSPS$ )

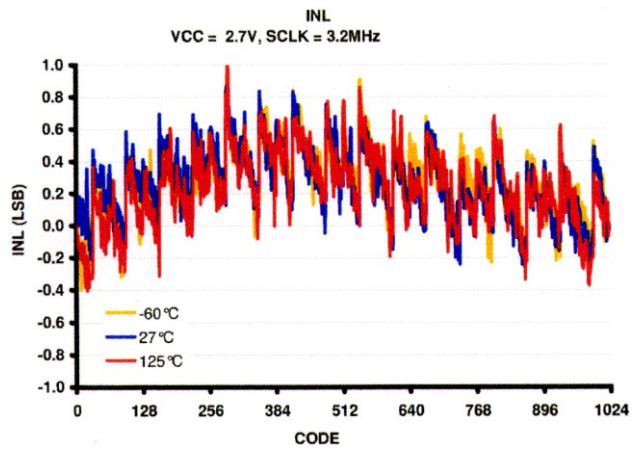

Figure 8. INL vs OUTPUT CODE  
( $V_{DD}=2.7V$ ,  $f_{SCLK}=3.2MHz$ ,  $f_{SAMPLE}=200kSPS$ )

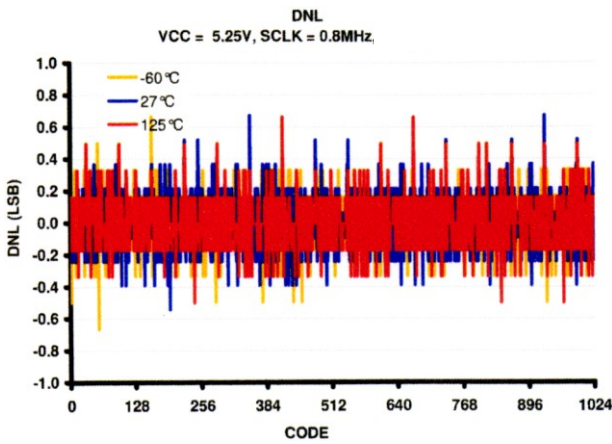

Figure 9. DNL vs OUTPUT CODE  
( $V_{DD}=5.25V$ ,  $f_{SCLK}=0.8MHz$ ,  $f_{SAMPLE}=50kSPS$ )

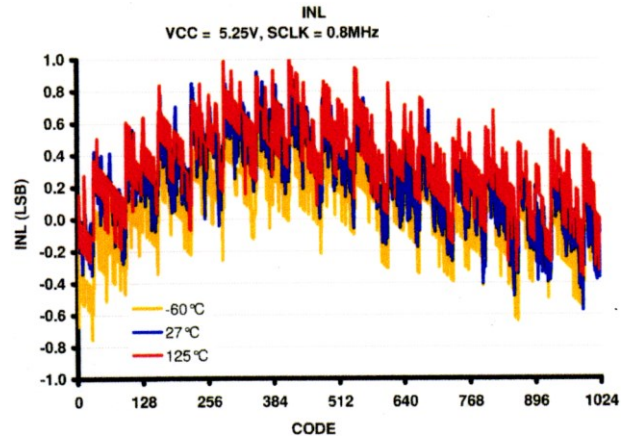

Figure 10. INL vs OUTPUT CODE  
( $V_{DD}=5.25V$ ,  $f_{SCLK}=0.8MHz$ ,  $f_{SAMPLE}=50kSPS$ )

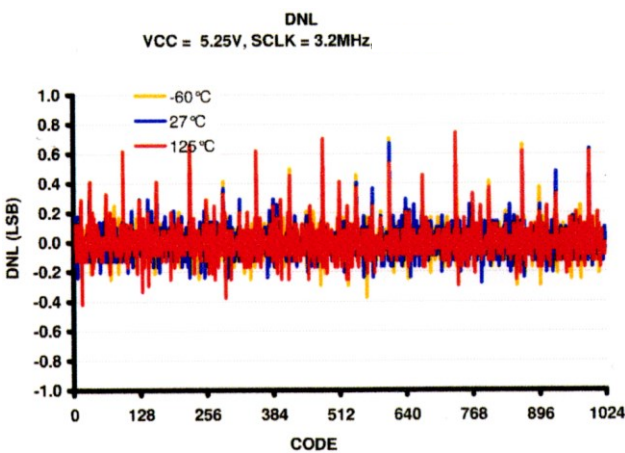

Figure 11. DNL vs OUTPUT CODE  
( $V_{DD}=5.25V$ ,  $f_{SCLK}=3.2MHz$ ,  $f_{SAMPLE}=200kSPS$ )

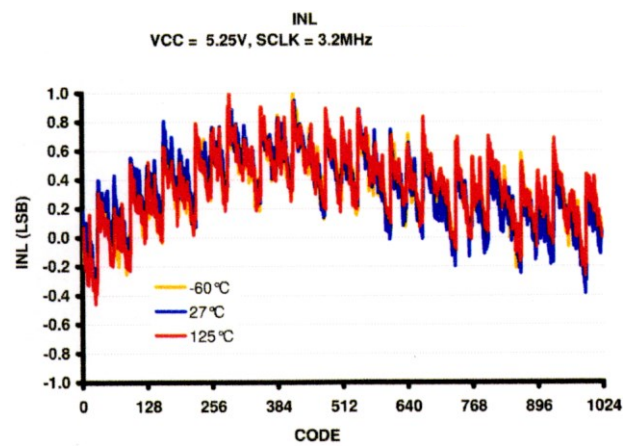
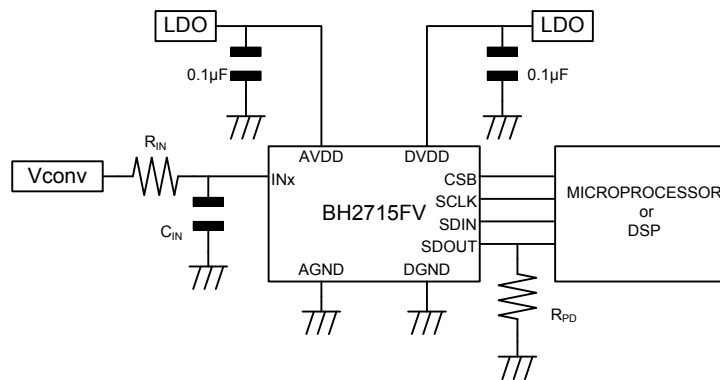

Figure 12. INL vs OUTPUT CODE  
( $V_{DD}=5.25V$ ,  $f_{SCLK}=3.2MHz$ ,  $f_{SAMPLE}=200kSPS$ )

(\*)The data above is measurement value of typical sample, it is not guaranteed.



## Application Circuit Example



## Consideration Point

## 1. Bypass Capacitor

Because the voltages of AVDD and AGND are used as the reference voltages for the A/D conversion, the deviation of the supply voltages directly affects A/D conversion accuracy. Please ensure to insert a low ESR bypass condenser (equal to or more than 0.1µF) between AVDD and AGND.

DVDD and DGND are the power supply and ground lines of the digital block. Please ensure to insert bypass condenser (equal to or more than 0.1µF) between DVDD and DGND.

## 2. Pull-down Resistor on SDOUT

SDOUT is a digital output terminal with a 3-state output buffer. When CSB=H, the SDOUT output is Hi-Z and the SDOUT line is floating. Please insert a pull-down resistor or a pull-up resistor as needed. A low resistance pull-up/pull-down resistor is not necessary, because SDOUT has a CMOS output buffer. Please insert a high resistance resistor. The resistance should be decided so that a circuit (microprocessor, etc.) which receives SDATA output doesn't malfunction.

## 3. External Circuit of Analog Input Terminals IN0 through IN7

Voltages of the terminals IN0 through IN7 are used for A/D conversions. Capacitors between the analog input terminals and ground should be placed as close to the analog input terminals as possible. A low ESR capacitor which has equal to or higher than 47pF is recommended. A capacitor  $C_{IN}$  should be connected to a ground with low noise like AGND. When conversion results are not stable, please insert a resistor  $R_{IN}$  between Vconv, which is an A/D conversion input voltage, and INx. Conversion results are improved by a first-order low pass filter composed of  $C_{IN}$  and  $R_{IN}$ . Please decide the values of  $C_{IN}$  and  $R_{IN}$  in consideration of the slew-rate or the frequency characteristic of Vconv. The lower cut-off frequency of the low pass filter makes the higher noise rejection rate from Vconv and the better A/D conversion characteristics of the BH2715FV as long as the low pass filter rejects a necessary signal frequency in Vconv.

## 4. Crosstalk between Analog Input Terminals and Noise Sources

Design a wire layout on a printed circuit board which doesn't cause crosstalk between the A/D conversion input signal lines IN0 through IN7 and other signal lines of possible noise sources due to capacitive coupling. Particularly, it should be avoided to route a input signal line in parallel with a noise source line. If it is unavoidable that an A/D conversion input line intersects with a noise source line, it is desired to make it orthogonal and also to take a measure to prevent crosstalk such as inserting a ground shield between layers of the printed circuit board.

I/O Equivalence Circuit

1. Analog Input Terminal

(1) Selected CH in Track Mode

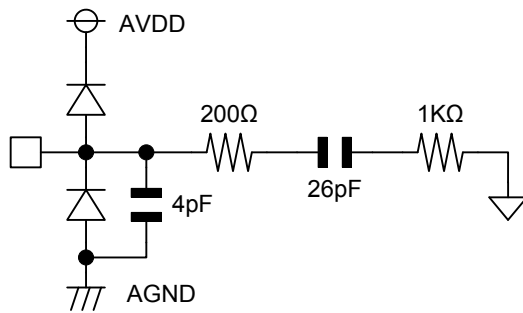

(2) Unselected CH or Selected CH in Hold Mode

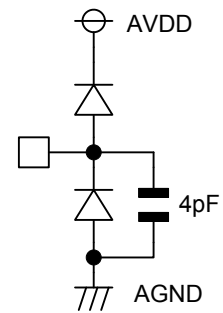

2. Digital Input Terminal

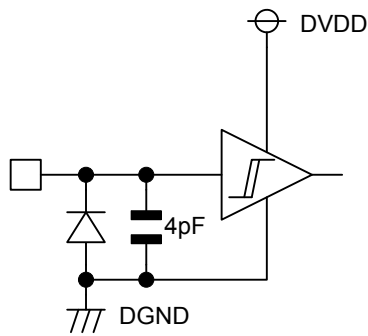

3. Digital Output Terminal

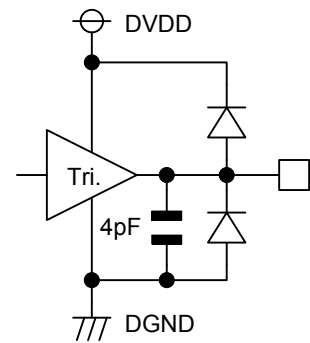

## Operational Notes

### 1. Reverse Connection of Power Supply

Connecting the power supply in reverse polarity can damage the IC. Take precautions against reverse polarity when connecting the power supply, such as mounting an external diode between the power supply and the IC's power supply pins.

### 2. Power Supply Lines

Design the PCB layout pattern to provide low impedance supply lines. Separate the ground and supply lines of the digital and analog blocks to prevent noise in the ground and supply lines of the digital block from affecting the analog block. Furthermore, connect a capacitor to ground at all power supply pins. Consider the effect of temperature and aging on the capacitance value when using electrolytic capacitors.

### 3. Ground Voltage

Ensure that no pins are at a voltage below that of the ground pin at any time, even during transient condition.

### 4. Ground Wiring Pattern

When using both small-signal and large-current ground traces, the two ground traces should be routed separately but connected to a single ground at the reference point of the application board to avoid fluctuations in the small-signal ground caused by large currents. Also ensure that the ground traces of external components do not cause variations on the ground voltage. The ground lines must be as short and thick as possible to reduce line impedance.

### 5. Thermal Consideration

Should by any chance the maximum junction temperature rating be exceeded the rise in temperature of the chip may result in deterioration of the properties of the chip. In case of exceeding this absolute maximum rating, increase the board size and copper area to prevent exceeding the maximum junction temperature rating.

### 6. Recommended Operating Conditions

These conditions represent a range within which the expected characteristics of the IC can be approximately obtained. The electrical characteristics are guaranteed under the conditions of each parameter.

### 7. Inrush Current

When power is first supplied to the IC, it is possible that the internal logic may be unstable and inrush current may flow instantaneously due to the internal powering sequence and delays, especially if the IC has more than one power supply. Therefore, give special consideration to power coupling capacitance, power wiring, width of ground wiring, and routing of connections.

### 8. Operation Under Strong Electromagnetic Field

Operating the IC in the presence of a strong electromagnetic field may cause the IC to malfunction.

### 9. Testing on Application Boards

When testing the IC on an application board, connecting a capacitor directly to a low-impedance output pin may subject the IC to stress. Always discharge capacitors completely after each process or step. The IC's power supply should always be turned off completely before connecting or removing it from the test setup during the inspection process. To prevent damage from static discharge, ground the IC during assembly and use similar precautions during transport and storage.

### 10. Inter-pin Short and Mounting Errors

Ensure that the direction and position are correct when mounting the IC on the PCB. Incorrect mounting may result in damaging the IC. Avoid nearby pins being shorted to each other especially to ground, power supply and output pin. Inter-pin shorts could be due to many reasons such as metal particles, water droplets (in very humid environment) and unintentional solder bridge deposited in between pins during assembly to name a few.

### 11. Unused Input Pins

Input pins of an IC are often connected to the gate of a MOS transistor. The gate has extremely high impedance and extremely low capacitance. If left unconnected, the electric field from the outside can easily charge it. The small charge acquired in this way is enough to produce a significant effect on the conduction through the transistor and cause unexpected operation of the IC. So unless otherwise specified, unused input pins should be connected to the power supply or ground line.

Operational Notes – continued

12. Regarding the Input Pin of the IC

In the construction of this IC, P-N junctions are inevitably formed creating parasitic diodes or transistors. The operation of these parasitic elements can result in mutual interference among circuits, operational faults, or physical damage. Therefore, conditions which cause these parasitic elements to operate, such as applying a voltage to an input pin lower than the ground voltage should be avoided. Furthermore, do not apply a voltage to the input pins when no power supply voltage is applied to the IC. Even if the power supply voltage is applied, make sure that the input pins have voltages within the values specified in the electrical characteristics of this IC.

13. Ceramic Capacitor

When using a ceramic capacitor, determine the dielectric constant considering the change of capacitance with temperature and the decrease in nominal capacitance due to DC bias and others.

Ordering Information

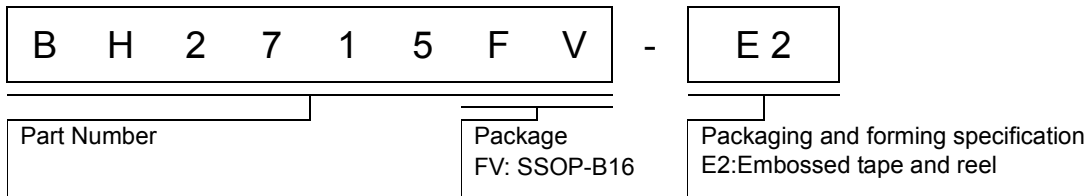

Marking Diagrams

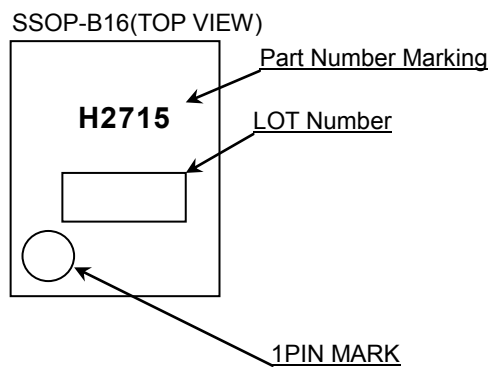

Physical Dimension, Tape and Reel Information

Package Name	SSOP-B16
--------------	----------

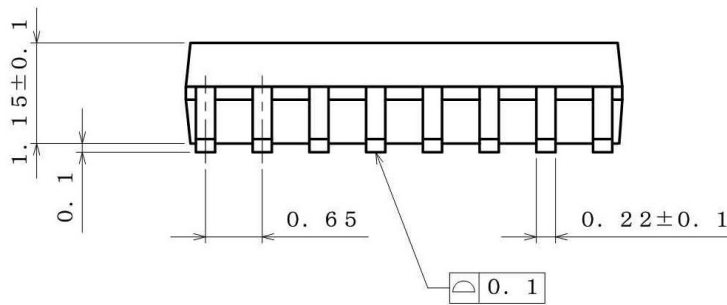
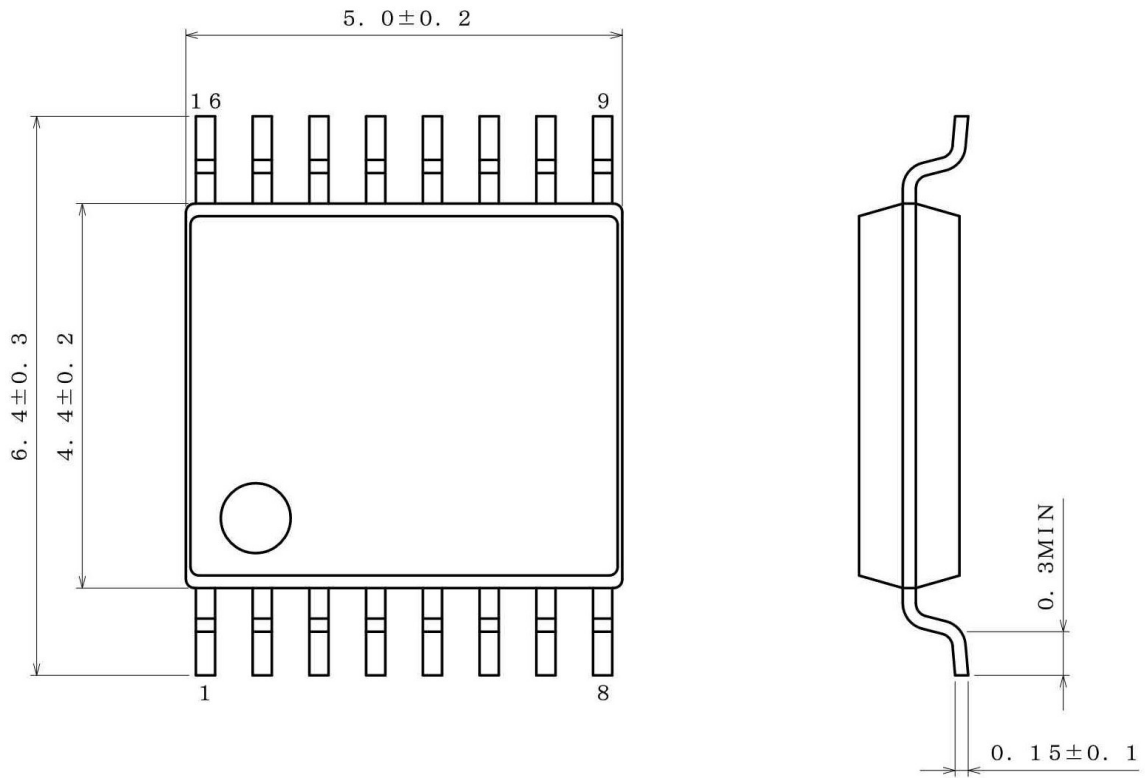

(UNIT : mm)  
 PKG : SSOP-B16  
 Drawing No. B0771

**<Tape and Reel information>**

Tape	Embossed carrier tape
Quantity	2500pcs
Direction of feed	E2 ( The direction is the 1pin of product is at the upper left when you hold reel on the left hand and you pull out the tape on the right hand )

1pin  
 \*Order quantity needs to be multiple of the minimum quantity.

## Revision History

Date	Revision	Changes
25.Feb.2016	002	New Release

# Notice

## Precaution on using ROHM Products

- Our Products are designed and manufactured for application in ordinary electronic equipments (such as AV equipment, OA equipment, telecommunication equipment, home electronic appliances, amusement equipment, etc.). If you intend to use our Products in devices requiring extremely high reliability (such as medical equipment <sup>(Note 1)</sup>, transport equipment, traffic equipment, aircraft/spacecraft, nuclear power controllers, fuel controllers, car equipment including car accessories, safety devices, etc.) and whose malfunction or failure may cause loss of human life, bodily injury or serious damage to property ("Specific Applications"), please consult with the ROHM sales representative in advance. Unless otherwise agreed in writing by ROHM in advance, ROHM shall not be in any way responsible or liable for any damages, expenses or losses incurred by you or third parties arising from the use of any ROHM's Products for Specific Applications.

(Note1) Medical Equipment Classification of the Specific Applications

JAPAN	USA	EU	CHINA
CLASS III	CLASS III	CLASS II b	CLASS III
CLASS IV		CLASS III	

- ROHM designs and manufactures its Products subject to strict quality control system. However, semiconductor products can fail or malfunction at a certain rate. Please be sure to implement, at your own responsibilities, adequate safety measures including but not limited to fail-safe design against the physical injury, damage to any property, which a failure or malfunction of our Products may cause. The following are examples of safety measures:
  - Installation of protection circuits or other protective devices to improve system safety
  - Installation of redundant circuits to reduce the impact of single or multiple circuit failure
- Our Products are designed and manufactured for use under standard conditions and not under any special or extraordinary environments or conditions, as exemplified below. Accordingly, ROHM shall not be in any way responsible or liable for any damages, expenses or losses arising from the use of any ROHM's Products under any special or extraordinary environments or conditions. If you intend to use our Products under any special or extraordinary environments or conditions (as exemplified below), your independent verification and confirmation of product performance, reliability, etc. prior to use, must be necessary:
  - Use of our Products in any types of liquid, including water, oils, chemicals, and organic solvents
  - Use of our Products outdoors or in places where the Products are exposed to direct sunlight or dust
  - Use of our Products in places where the Products are exposed to sea wind or corrosive gases, including Cl<sub>2</sub>, H<sub>2</sub>S, NH<sub>3</sub>, SO<sub>2</sub>, and NO<sub>2</sub>
  - Use of our Products in places where the Products are exposed to static electricity or electromagnetic waves
  - Use of our Products in proximity to heat-producing components, plastic cords, or other flammable items
  - Sealing or coating our Products with resin or other coating materials
  - Use of our Products without cleaning residue of flux (even if you use no-clean type fluxes, cleaning residue of flux is recommended); or Washing our Products by using water or water-soluble cleaning agents for cleaning residue after soldering
  - Use of the Products in places subject to dew condensation
- The Products are not subject to radiation-proof design.
- Please verify and confirm characteristics of the final or mounted products in using the Products.
- In particular, if a transient load (a large amount of load applied in a short period of time, such as pulse. is applied, confirmation of performance characteristics after on-board mounting is strongly recommended. Avoid applying power exceeding normal rated power; exceeding the power rating under steady-state loading condition may negatively affect product performance and reliability.
- De-rate Power Dissipation depending on ambient temperature. When used in sealed area, confirm that it is the use in the range that does not exceed the maximum junction temperature.
- Confirm that operation temperature is within the specified range described in the product specification.
- ROHM shall not be in any way responsible or liable for failure induced under deviant condition from what is defined in this document.

## Precaution for Mounting / Circuit board design

- When a highly active halogenous (chlorine, bromine, etc.) flux is used, the residue of flux may negatively affect product performance and reliability.
- In principle, the reflow soldering method must be used on a surface-mount products, the flow soldering method must be used on a through hole mount products. If the flow soldering method is preferred on a surface-mount products, please consult with the ROHM representative in advance.

For details, please refer to ROHM Mounting specification



### Precautions Regarding Application Examples and External Circuits

1. If change is made to the constant of an external circuit, please allow a sufficient margin considering variations of the characteristics of the Products and external components, including transient characteristics, as well as static characteristics.
2. You agree that application notes, reference designs, and associated data and information contained in this document are presented only as guidance for Products use. Therefore, in case you use such information, you are solely responsible for it and you must exercise your own independent verification and judgment in the use of such information contained in this document. ROHM shall not be in any way responsible or liable for any damages, expenses or losses incurred by you or third parties arising from the use of such information.

### Precaution for Electrostatic

This Product is electrostatic sensitive product, which may be damaged due to electrostatic discharge. Please take proper caution in your manufacturing process and storage so that voltage exceeding the Products maximum rating will not be applied to Products. Please take special care under dry condition (e.g. Grounding of human body / equipment / solder iron, isolation from charged objects, setting of Ionizer, friction prevention and temperature / humidity control).

### Precaution for Storage / Transportation

1. Product performance and soldered connections may deteriorate if the Products are stored in the places where:
  - [a] the Products are exposed to sea winds or corrosive gases, including Cl<sub>2</sub>, H<sub>2</sub>S, NH<sub>3</sub>, SO<sub>2</sub>, and NO<sub>2</sub>
  - [b] the temperature or humidity exceeds those recommended by ROHM
  - [c] the Products are exposed to direct sunshine or condensation
  - [d] the Products are exposed to high Electrostatic
2. Even under ROHM recommended storage condition, solderability of products out of recommended storage time period may be degraded. It is strongly recommended to confirm solderability before using Products of which storage time is exceeding the recommended storage time period.
3. Store / transport cartons in the correct direction, which is indicated on a carton with a symbol. Otherwise bent leads may occur due to excessive stress applied when dropping of a carton.
4. Use Products within the specified time after opening a humidity barrier bag. Baking is required before using Products of which storage time is exceeding the recommended storage time period.

### Precaution for Product Label

A two-dimensional barcode printed on ROHM Products label is for ROHM's internal use only.

### Precaution for Disposition

When disposing Products please dispose them properly using an authorized industry waste company.

### Precaution for Foreign Exchange and Foreign Trade act

Since concerned goods might be fallen under listed items of export control prescribed by Foreign exchange and Foreign trade act, please consult with ROHM in case of export.

### Precaution Regarding Intellectual Property Rights

1. All information and data including but not limited to application example contained in this document is for reference only. ROHM does not warrant that foregoing information or data will not infringe any intellectual property rights or any other rights of any third party regarding such information or data.
2. ROHM shall not have any obligations where the claims, actions or demands arising from the combination of the Products with other articles such as components, circuits, systems or external equipment (including software).
3. No license, expressly or implied, is granted hereby under any intellectual property rights or other rights of ROHM or any third parties with respect to the Products or the information contained in this document. Provided, however, that ROHM will not assert its intellectual property rights or other rights against you or your customers to the extent necessary to manufacture or sell products containing the Products, subject to the terms and conditions herein.

### Other Precaution

1. This document may not be reprinted or reproduced, in whole or in part, without prior written consent of ROHM.
2. The Products may not be disassembled, converted, modified, reproduced or otherwise changed without prior written consent of ROHM.
3. In no event shall you use in any way whatsoever the Products and the related technical information contained in the Products or this document for any military purposes, including but not limited to, the development of mass-destruction weapons.
4. The proper names of companies or products described in this document are trademarks or registered trademarks of ROHM, its affiliated companies or third parties.

**General Precaution**

1. Before you use our Products, you are requested to carefully read this document and fully understand its contents. ROHM shall not be in any way responsible or liable for failure, malfunction or accident arising from the use of any ROHM's Products against warning, caution or note contained in this document.
2. All information contained in this document is current as of the issuing date and subject to change without any prior notice. Before purchasing or using ROHM's Products, please confirm the latest information with a ROHM sales representative.
3. The information contained in this document is provided on an "as is" basis and ROHM does not warrant that all information contained in this document is accurate and/or error-free. ROHM shall not be in any way responsible or liable for any damages, expenses or losses incurred by you or third parties resulting from inaccuracy or errors of or concerning such information.

## X-ON Electronics

Largest Supplier of Electrical and Electronic Components

*Click to view similar products for [Analog to Digital Converters - ADC category](#):*

*Click to view products by [ROHM manufacturer](#):*

Other Similar products are found below :

[ADC0804LCD](#) [ADC0808](#) [MCP37211-200I/TE](#) [MAX15511TGTL+](#) [MCP3202T-CI/MS](#) [ADE1201ACCZ](#) [ADE1202ACCZ](#) [LTC1090CN](#)  
[LTC1605IG](#) [LTC1605AIG](#) [LTC2208IUP](#) [ADS1282HPW](#) [LTC1297DCN8](#) [LTC1741CFW](#) [MCP3422A0-E/MS](#) [MCP3426A2-E/MC](#)  
[MCP3426A3-E/MC](#) [MCP3427-E/MF](#) [TLC0820ACN](#) [TLC2543IN](#) [TLV2543IDW](#) [NCD9830DBR2G](#) [ADS5231IPAG](#) [ADS7807U](#)  
[ADS7891IPFBT](#) [ADS8328IBPW](#) [AMC1204BDWR](#) [ADS7959QDBTRQ1](#) [ADS7807UB](#) [ADS7805UB](#) [ADS1220IPWR](#) [MCP3426A0-E/MS](#)  
[MCP3423-E/UN](#) [MCP3422A0-E/MC](#) [AD9220AR](#) [MAX11123ATI+](#) [MAX11212AEUB+](#) [MAX11135ATI+](#) [TLV1570CDW](#) [TLC3574IDWR](#)  
[TLC0838CDWR](#) [AD7714ARZ-5REEL](#) [AD7914BRUZ-REEL7](#) [AD977ABRZ](#) [ADC101S021CIMFX/NOPB](#) [ADC12130CIWM/NOPB](#)  
[MAX11213EEE+](#) [MAX11626EEE+](#) [MAX11136ATI+](#) [MAX11628EEE+](#)