

DC Brushless Motor Drivers for Cooling Fans

Three-Phase Full-Wave Fan Motor Driver for Note PC



BH6717NUV

No.12010EAT18

●Description

BH6717NUV is a three-phase sensorless fan motor driver used to cool off notebook PCs. It is controlled by a variable speed provided through the PWM input signal. Its feature is sensorless drive which doesn't require a hall device as a location detection sensor and motor downsizing can be achieved by limiting the number of external components as much as possible. Furthermore, introducing a direct PWM soft switched driving mechanism achieves silent operations and low vibrations.

●Features

- 1) Speed controllable by PWM input signal
- 2) Sensorless drive
- 3) Soft switched drive
- 4) Power save function

●Applications

small fan motor notebook PCs etc

●Absolute maximum ratings(Ta=25°C)

Parameter	Symbol	Ratings	Unit
Supply voltage	VCC	-0.3~6.5	V
Power dissipation	Pd	560 *	mW
Operating temperature	Topr	-25~+95	°C
Storage temperature	Tstg	-55~+125	°C
Output current	Iomax	700 **	mA
FG signal output voltage	VFG	6.5	V
FG signal output current	IFG	6	mA
Junction temperature	Tjmax	125	°C

* Reduce by 5.6mW/°C over 25/°C. (On 70mm × 70mm × 1.6mm glass epoxy board)

** This value is not to exceed Pd.

●Operating conditions

Parameter	Symbol	Ratings	Unit
Operating supply voltage range	VCC	1.8 ~ 5.5	V

*These specifications might change for their improvement etc.

●Electrical characteristics(Unless otherwise specified VCC=5V, Ta=25°C)

Parameter	Symbol	Limits			Unit	Conditions
		Min.	Typ.	Max.		
Circuit current STB	ICST	-	20	50	μ A	
Circuit current	ICC		4		mA	
PWM input H level	VPH	2.5	-	VCC	V	
PWM input L level	VPL	0	-	0.7	V	
PWM input current H	IPH	-	0	1	μ A	PWM=VCC
PWM input current L	IPL	-50	-20	-	μ A	PWM=GND
Input frequency	FP	20	-	50	kHz	
FR input H level	VFRH	4.5	-	VCC	V	FR=H : Reverse drive
FR input L level	VFRL	0	-	0.5	V	FR=L : Forward drive
PWM off time	TPO	500	1000	2000	μ s	
Limit voltage	VLM	0.2	0.25	0.3	V	
Output voltage	VO	-	0.25	0.325	V	Io=250mA (H.L. total)
FG low voltage	VFGL	-	-	0.4	V	IFG=5mA
Lock protection det.time	LDT	-	0.5	-	s	
Lock protection rel.time	LRT	2.5	5	10	s	
Lock protection ratio	RLT	-	10	-	-	rel.time/det.time ratio

Package outlines (Unit : mm)

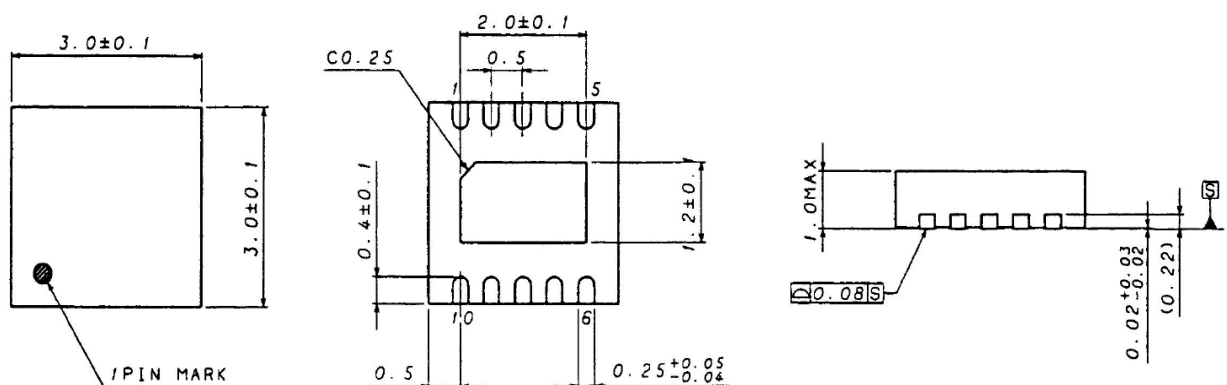

Package : VSON010V3030

●Block diagram

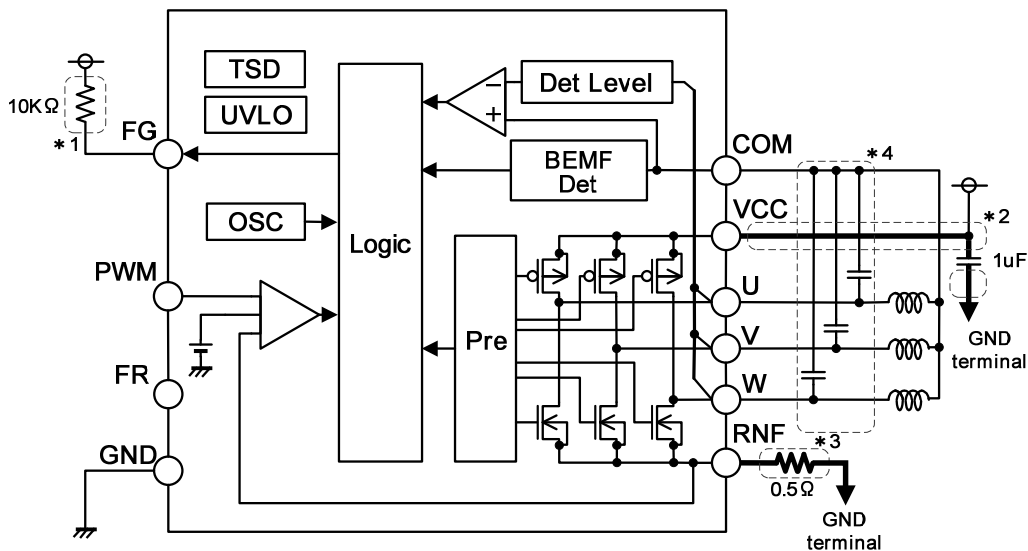

OSC : Oscillation circuit TSD : Thermal shutdown (heat rejection circuit) Pre : Pre driver
 UVLO : Under voltage lock out circuit BEMF Det : Induced electromotive voltage detection circuit
 Det Level : Offset circuit

- *1 Open collector output. A pull-up resistances of $10k\Omega$ should be inserted.
- *2 The wiring patterns from the VCC terminal and GND terminal to the bypass capacitor must be routed as short as possible. With respect to the wiring pattern, It has been confirmed that 0.03 for $1\mu F$ at the bypass capacitor doesn't cause problems under our operation environment. This can be used as a reference value to check for validity.
- *3 Be careful with the wattage because a large current may pass through the output current detection resistance. The current limit value is determined by the internal limit voltage value (typ.0.25V) and the output current detection resistance (See Description of Functional Operation 3.). Accordingly, the resistance of the wiring pattern routed from the RNF terminal and GND terminal to the output current detection resistance also affects to the current limit value, and therefore the resistance of the wiring pattern should be as small as possible.
- *4 When it is noisy, Capacitance should be inserted between U,V,and W,.

●Pin assignment

Pin No.	Terminal name	Function
1	FG	FG output terminal
2	COM	Coil midpoint terminal
3	VCC	Power supply terminal
4	U	U phase output terminal
5	RNF	Current limit detection terminal
6	W	W phase output terminal
7	V	V phase output terminal
8	GND	GND terminal
9	FR	Forward/Reverse switch terminal
10	PWM	PWM signal input terminal

●Description of Function Operation

1. Sensorless Drive

BH6717NUV is a motor driver IC for driving a three-phase brushless DC motor without a hall sensor. Detecting a rotor location firstly at startup, an appropriate logic for the rotation direction is obtained using this information and given to each phase to rotate the motor. Then, the rotation of the motor induces electromotive voltage in each phase wiring and the logic based on the induced electromotive voltage is applied to the each phase to continue rotating.

2. Lock Protection Feature, Automatic Recovery Circuit

To prevent passing a coil current on any phase when a motor is locked, it is provided with a function which can turn OFF the output for a certain period of time and then automatically restore itself to the normal operation. During the motor rotation, an appropriate logic based on the induced electromotive voltage can be continuously given to each phase; on the other hand, when the motor is locked, no induced electromotive voltage is obtained. Utilizing this phenomenon to take a protective against locking, when the induced electromotive voltage is not detected for a predetermined period of time (TON), it is judged that the motor is locked and the output is turned OFF for a predetermined period of time (TOFF). In Fig.1, the timing chart is shown.

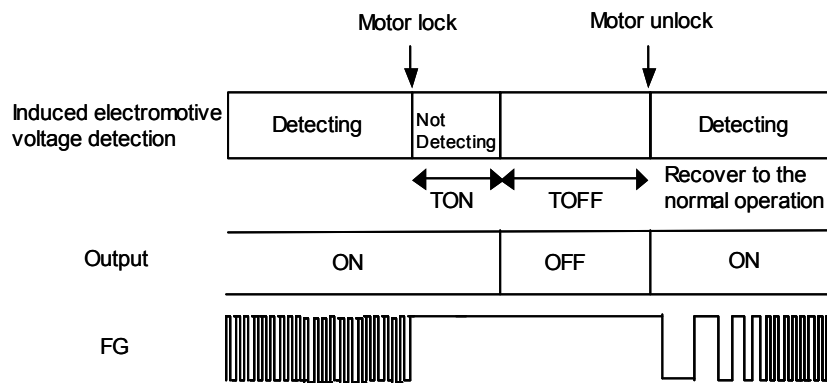

Fig.1

3. Current limit circuit

A current passing through the motor coil can be detected on the output current detection resistance to prohibit a current flow larger than a current limit value. The current limit value is determined by settings of the IC internal limit voltage: 0.25V (typ.) and the output current detection resistance value using the following equation:

$$\text{Current limit value(mA)} = \frac{\text{Internal limit voltage}(0.25\text{V})}{\text{Output current detection resistance}(\Omega)}$$

For example the RNF resistance is 0.5Ω, the current limit is activated at 500mA by calculation.

4. UVLO (Under voltage lock out circuit)

In the operation area under the guaranteed operating power supply voltage of 1.8V (typ.), the transistor on the output can be turned OFF at a power supply voltage of 1.58V (typ.). A hysteresis width of 100mV is provided and a normal operation can be performed at 1.68V. This function is installed to prevent unpredictable operations, such as a large amount of current passing through the output, by means of intentionally turning OFF the output during an operation at a very low power supply voltage which may cause an abnormal function in the internal circuit.

5. Power saving function / Speed control by PWM input

The power saving function is controlled by an input logic of the PWM terminal.

- (a) Operate mode when the PWM terminal is High.
- (b) Standby mode when the PWM terminal is Low for a time period of 1ms (typ.).

When the PWM terminal is open, High logic is set.

Input logic of the PWM terminal is set at Low and then the Standby mode becomes effective 1ms (typ.) (Fig.2). In the Standby mode, the lock protection function is deactivated and the lock protection is not effective. Therefore, this device can start up instantly even from the stop state when the input logic of the PWM terminal is set at High.

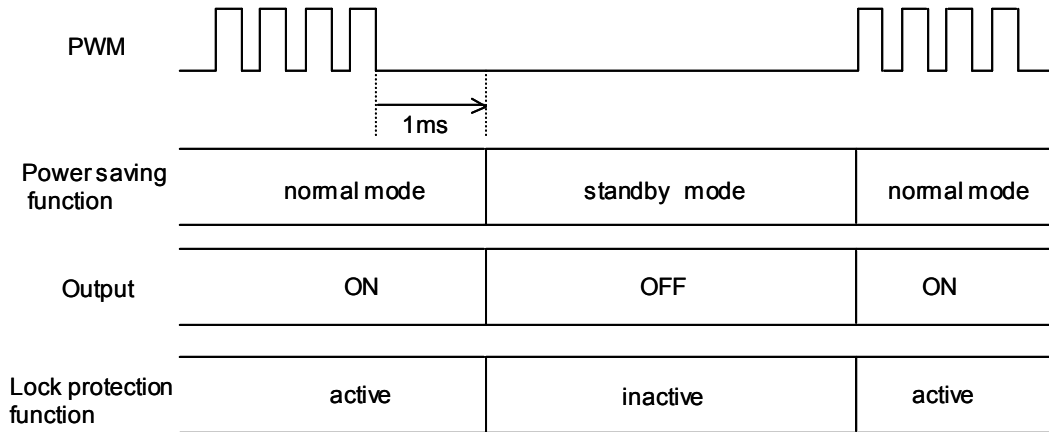

Fig.2

• Speed Control by PWM input

Depending on the Duty value of the input signal on the PWM terminal, the output is controlled by switching between ON and OFF. The higher Duty value results in the higher motor rotation speed, while the lower Duty value the lower speed.

6. U,V,W phase and FG output signals

In Fig.3, the timing charts of the output signals from the U, V and W phases as well as the FG terminal is shown. Assuming that a three-slot tetrode motor is used, two pulse outputs of FG are produced for one motorcycle. The three phases are excited in the order of U, V and W phases.

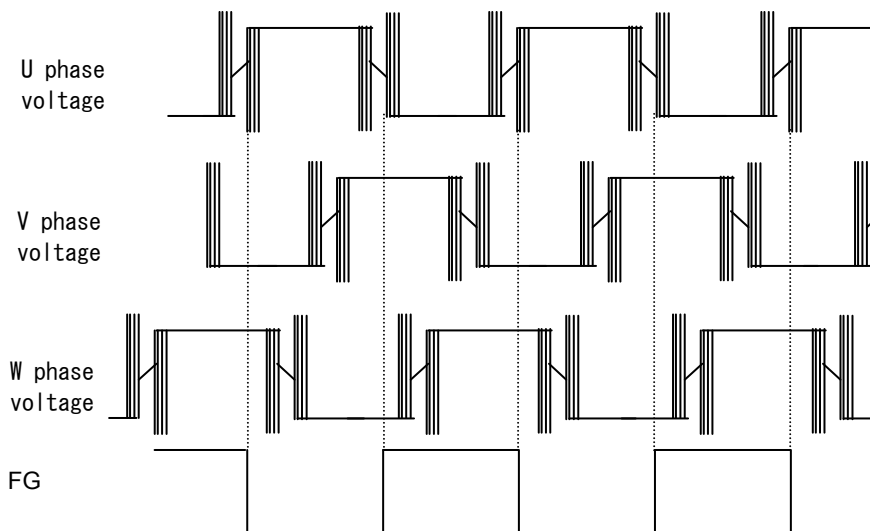
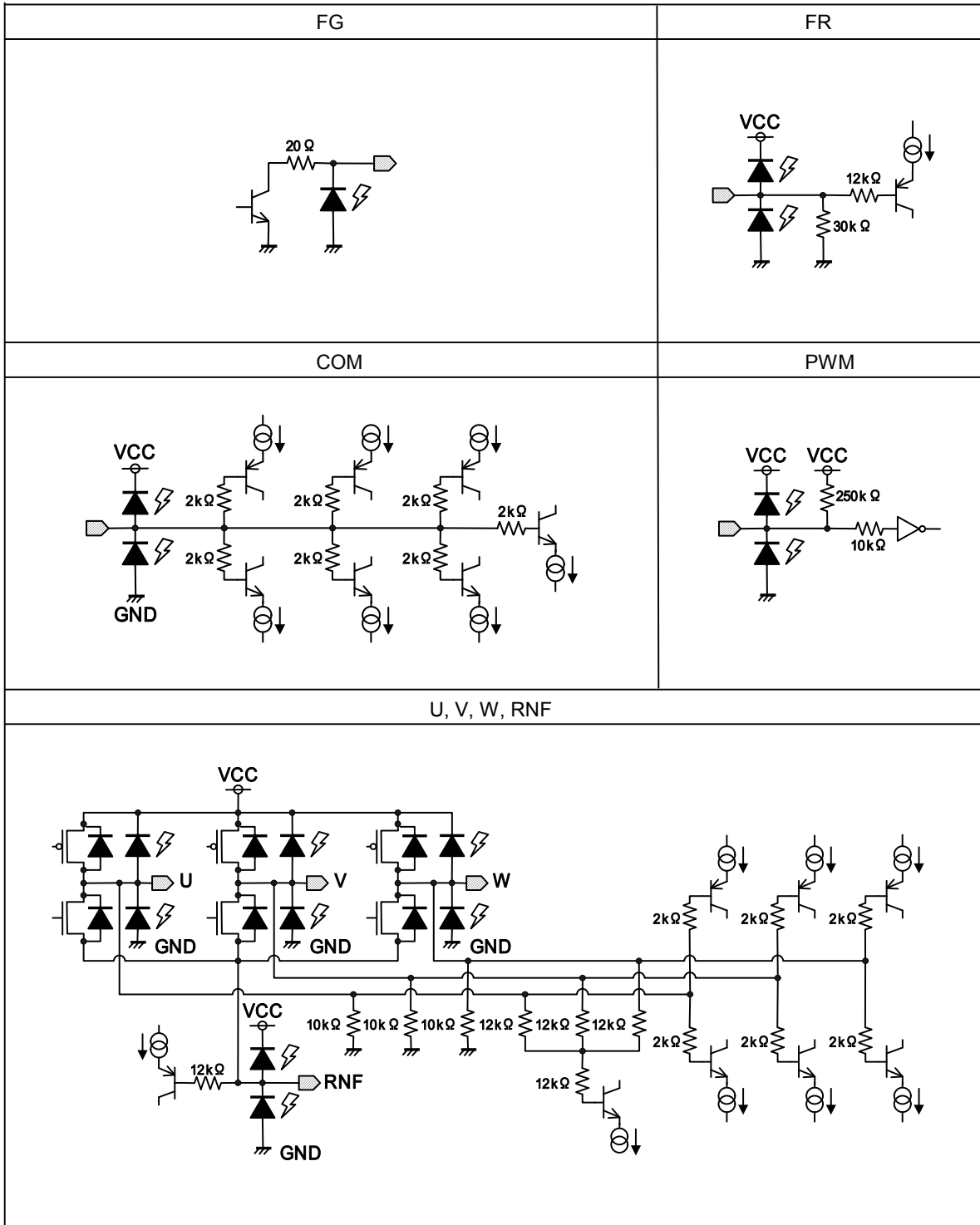

Fig.3

Equivalent circuit



● Thermal derating curve

Permissible dissipation (total loss) indicates the power that can be consumed by IC at Ta = 25°C (normal temperature). IC is heated when it consumes power, and the temperature of IC chip becomes higher than ambient temperature. The temperature that can be accepted by IC chip depends on circuit configuration, manufacturing process, etc, and consumable power is limited. Permissible dissipation is determined by the temperature allowed in IC chip (maximum junction temperature) and thermal resistance of package (heat dissipation capability). The maximum junction temperature is in general equal to the maximum value in the storage temperature range.

Heat generated by consumed power of IC is radiated from the mold resin or lead frame of package. The parameter which indicates this heat dissipation capability (hardness of heat release) is called heat resistance, represented by the symbol θ_{ja} [°C/W]. The temperature of IC inside the package can be estimated by this heat resistance. Below Figure shows the model of heat resistance of the package.

Heat resistance θ_{ja} , ambient temperature Ta, junction temperature Tj, and power consumption P can be calculated by the equation below:

$$\theta_{ja} = (T_j - T_a) / P \quad [^{\circ}\text{C}/\text{W}]$$

Thermal derating curve indicates power that can be consumed by IC with reference to ambient temperature. Power that can be consumed by IC begins to attenuate at certain ambient temperature. This gradient is determined by thermal resistance θ_{ja} .

Thermal resistance θ_{ja} depends on chip size, power consumption, package ambient temperature, packaging condition, wind velocity, etc even when the same package is used. Thermal derating curve indicates a reference value measured at a specified condition. Below Figure shows a thermal derating curve. (Value when mounting FR4 glass epoxy board 70 [mm] x 70 [mm] x 1.6 [mm] (copper foil area below 3 [%]))

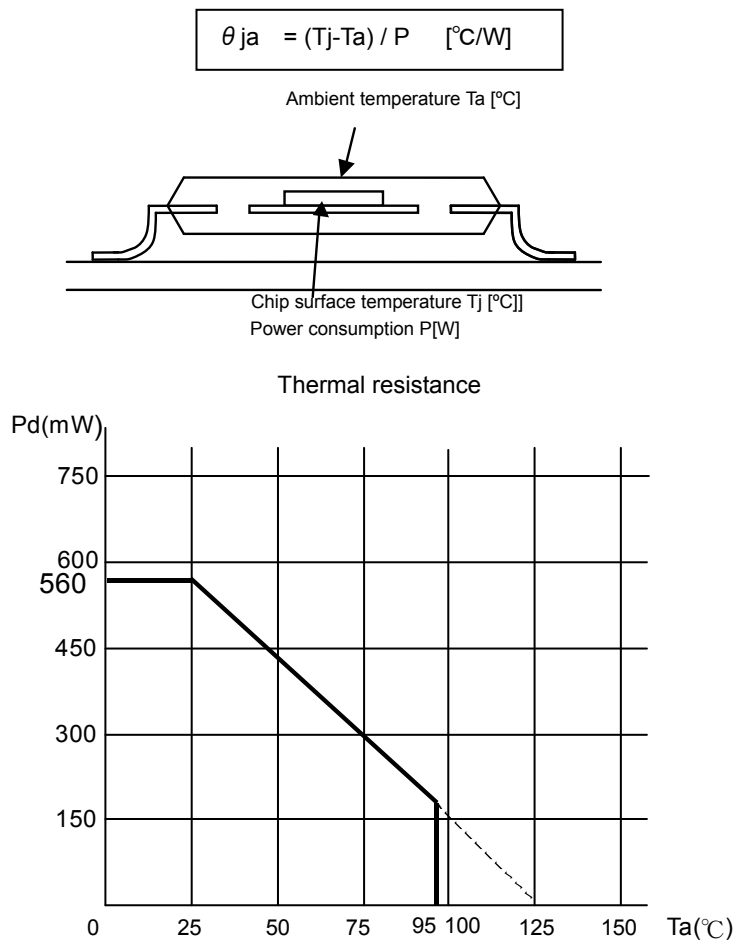

* Above Ta = 25°C, derating by 5.6 mW/°C
(When glass epoxy board of 70.0 mm x 70.0 mm x 1.6 mm is mounted)

Thermal derating curve

●Note for contents

1) To explain about function of operation, timing charts might be partly omitted.

●Location of IC (Generally three-phase sensorless driver IC)

- 1) Generally, three-phase sensorless driver is rotated motor by detecting the induced electromotive voltage. Line noise, line resistance is influenced for detecting the induced electromotive voltage. From motor to IC line should be shorted, its suggest that location of IC is on the board of Motor in below Fig.4.
- 2) In three-phase sensorless and variable speed driver, It is necessary to tuning motor and IC (each motor units). (Usually Motor maker does it to tuning motor and IC.)

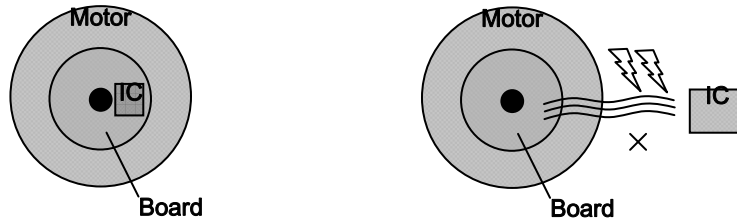

Fig.4

●Cautions on use

- 1) Absolute maximum ratings
An excess in the absolute maximum ratings, such as supply voltage, temperature range of operating conditions, etc., can break down the devices, thus making impossible to identify breaking mode, such as a short circuit or an open circuit. If any over rated values will expect to exceed the absolute maximum ratings, consider adding circuit protection devices, such as fuses.
- 2) Connecting the power supply connector backward
Connecting of the power supply in reverse polarity can damage IC. Take precautions when connecting the power supply lines. An external direction diode can be added.
- 3) Power supply line
Back electromotive force causes regenerated current to power supply line, therefore take a measure such as placing a capacitor between power supply and GND for routing regenerated current. And fully ensure that the capacitor characteristics have no problem before determine a capacitor value. (when applying electrolytic capacitors, capacitance characteristic values are reduced at low temperatures)
- 4) GND potential
The potential of GND pin must be minimum potential in all operating conditions. Also ensure that all terminals except GND terminal do not fall below GND voltage including transient characteristics. However, it is possible that the motor output terminal may deflect below GND because of influence by back electromotive force of motor. Malfunction may possibly occur depending on use condition, environment, and property of individual motor. Please make fully confirmation that no problem is found on operation of IC.
- 5) Thermal design
Use a thermal design that allows for a sufficient margin in light of the power dissipation (Pd) in actual operating conditions.
- 6) Inter-pin shorts and mounting errors
Use caution when positioning the IC for mounting on printed circuit boards. The IC may be damaged if there is any connection error or if pins are shorted together.
- 7) Actions in strong electromagnetic field
Use caution when using the IC in the presence of a strong electromagnetic field as doing so may cause the IC to malfunction.
- 8) ASO
When using the IC, set the output transistor so that it does not exceed absolute maximum ratings or ASO.
- 9) Thermal shut down circuit
The IC incorporates a built-in thermal shutdown circuit (TSD circuit). Operation temperature is 150°C(Typ.) and has a hysteresis width of 15°C(Typ.). When IC chip temperature rises and TSD circuit works, the output terminal becomes an open state. TSD circuit is designed only to shut the IC off to prevent thermal runaway. It is not designed to protect the IC or guarantee its operation. Do not continue to use the IC after operation this circuit or use the IC in an environment where the operation of this circuit is assumed.
- 10) Testing on application boards
When testing the IC on an application board, connecting a capacitor to a pin with low impedance subjects the IC to stress. Always discharge capacitors after each process or step. Always turn the IC's power supply off before connecting it to or removing it from a jig or fixture during the inspection process. Ground the IC during assembly steps as an antistatic measure. Use similar precaution when transporting or storing the IC.
- 11) GND wiring pattern
When using both small signal and large current GND patterns, it is recommended to isolate the two ground patterns, placing a single ground point at the ground potential of application so that the pattern wiring resistance and voltage variations caused by large currents do not cause variations in the small signal ground voltage. Be careful not to change the GND wiring pattern of any external components, either.
- 12) IC terminal input
When VCC voltage is not applied to IC, do not apply voltage to each input terminal. When voltage above VCC or below GND is applied to the input terminal, parasitic element is actuated due to the structure of IC. Operation of parasitic element causes mutual interference between circuits, resulting in malfunction as well as destruction in the last. Do not use in a manner where parasitic element is actuated.

●Physical Dimension

VSON010V3030

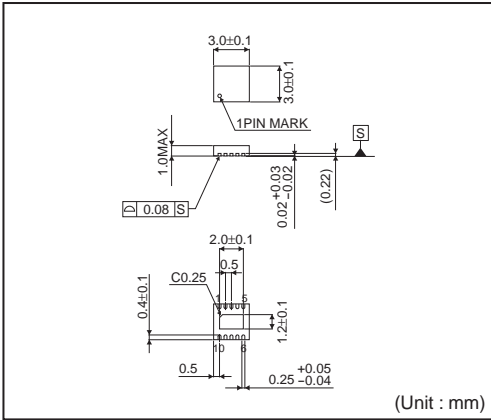

<Tape and Reel information>

Tape	Embossed carrier tape
Quantity	3000pcs
Direction of feed	E2 (The direction is the 1pin of product is at the upper left when you hold reel on the left hand and you pull out the tape on the right hand)

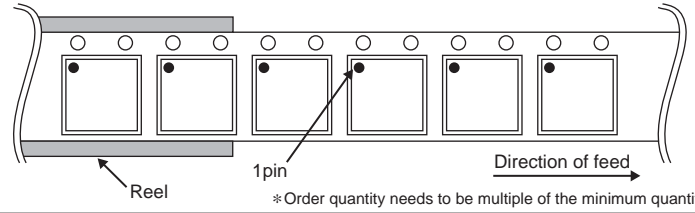

Notes

No copying or reproduction of this document, in part or in whole, is permitted without the consent of ROHM Co.,Ltd.

The content specified herein is subject to change for improvement without notice.

The content specified herein is for the purpose of introducing ROHM's products (hereinafter "Products"). If you wish to use any such Product, please be sure to refer to the specifications, which can be obtained from ROHM upon request.

Examples of application circuits, circuit constants and any other information contained herein illustrate the standard usage and operations of the Products. The peripheral conditions must be taken into account when designing circuits for mass production.

Great care was taken in ensuring the accuracy of the information specified in this document. However, should you incur any damage arising from any inaccuracy or misprint of such information, ROHM shall bear no responsibility for such damage.

The technical information specified herein is intended only to show the typical functions of and examples of application circuits for the Products. ROHM does not grant you, explicitly or implicitly, any license to use or exercise intellectual property or other rights held by ROHM and other parties. ROHM shall bear no responsibility whatsoever for any dispute arising from the use of such technical information.

The Products specified in this document are intended to be used with general-use electronic equipment or devices (such as audio visual equipment, office-automation equipment, communication devices, electronic appliances and amusement devices).

The Products specified in this document are not designed to be radiation tolerant.

While ROHM always makes efforts to enhance the quality and reliability of its Products, a Product may fail or malfunction for a variety of reasons.

Please be sure to implement in your equipment using the Products safety measures to guard against the possibility of physical injury, fire or any other damage caused in the event of the failure of any Product, such as derating, redundancy, fire control and fail-safe designs. ROHM shall bear no responsibility whatsoever for your use of any Product outside of the prescribed scope or not in accordance with the instruction manual.

The Products are not designed or manufactured to be used with any equipment, device or system which requires an extremely high level of reliability the failure or malfunction of which may result in a direct threat to human life or create a risk of human injury (such as a medical instrument, transportation equipment, aerospace machinery, nuclear-reactor controller, fuel-controller or other safety device). ROHM shall bear no responsibility in any way for use of any of the Products for the above special purposes. If a Product is intended to be used for any such special purpose, please contact a ROHM sales representative before purchasing.

If you intend to export or ship overseas any Product or technology specified herein that may be controlled under the Foreign Exchange and the Foreign Trade Law, you will be required to obtain a license or permit under the Law.



Thank you for your accessing to ROHM product informations.
More detail product informations and catalogs are available, please contact us.

ROHM Customer Support System

<http://www.rohm.com/contact/>

X-ON Electronics

Largest Supplier of Electrical and Electronic Components

Click to view similar products for [Motor/Motion/Ignition Controllers & Drivers](#) category:

Click to view products by [ROHM](#) manufacturer:

Other Similar products are found below :

[FSB50550TB2](#) [FSBF15CH60BTH](#) [MSVCPM2-63-12](#) [MSVGW45-14-2](#) [MSVGW54-14-3](#) [MSVGW54-14-5](#) [NTE7043](#) [LA6565VR-TLM-E](#)
[LB11650-E](#) [LB1837M-TLM-E](#) [LB1845DAZ-XE](#) [LC898300XA-MH](#) [SS30-TE-L-E](#) [26700](#) [LV8281VR-TLM-H](#) [BA5839FP-E2](#) [IRAM236-1067A](#) [LA6584JA-AH](#) [LB11847L-E](#) [NCV70501DW002R2G](#) [AH293-PL-B](#) [STK672-630CN-E](#) [TND315S-TL-2H](#) [FNA23060](#) [FSB50250AB](#)
[FNA41060](#) [MSVB54](#) [MSVBTC50E](#) [MSVCPM3-54-12](#) [MSVCPM3-63-12](#) [MSVCPM4-63-12](#) [MSVTA120](#) [FSB50550AB](#)
[NCV70501DW002G](#) [LC898301XA-MH](#) [LV8413GP-TE-L-E](#) [MSVGW45-14-3](#) [MSVGW45-14-4](#) [MSVGW45-14-5](#) [MSVGW54-14-4](#)
[STK984-091A-E](#) [MP6519GQ-Z](#) [LB11651-E](#) [IRSM515-025DA4](#) [LV8127T-TLM-H](#) [MC33812EKR2](#) [NCP81382MNTXG](#) [TDA21801](#)
[LB11851FA-BH](#) [NCV70627DQ001R2G](#)