

**Gate Driver**  
**BM60212FV-C Evaluation Board**  
**BM60212FV-EVK001**

## <High Voltage Safety Precautions>

◇ Read all safety precautions before use

Please note that this document covers only the BM60212FV-C evaluation board (BM60212FV-EVK001) and its functions. For additional information, please refer to the datasheet.

**To ensure safe operation, please carefully read all precautions before handling the evaluation board**



Depending on the configuration of the board and voltages used,

**Potentially lethal voltages may be generated.**

Therefore, please make sure to read and observe all safety precautions described in the red box below.

### Before Use

- [1] Verify that the parts/components are not damaged or missing (i.e. due to the drops).
- [2] Check that there are no conductive foreign objects on the board.
- [3] Be careful when performing soldering on the module and/or evaluation board to ensure that solder splash does not occur.
- [4] Check that there is no condensation or water droplets on the circuit board.

### During Use

- [5] Be careful to not allow conductive objects to come into contact with the board.
- [6] **Brief accidental contact or even bringing your hand close to the board may result in discharge and lead to severe injury or death.**

**Therefore, DO NOT touch the board with your bare hands or bring them too close to the board.** In addition, as mentioned above please exercise extreme caution when using conductive tools such as tweezers and screwdrivers.

- [7] If used under conditions beyond its rated voltage, it may cause defects such as short-circuit or, depending on the circumstances, explosion or other permanent damages.
- [8] Be sure to wear insulated gloves when handling is required during operation.

### After Use

- [9] The ROHM Evaluation Board contains the circuits which store the high voltage. Since it stores the charges even after the connected power circuits are cut, please discharge the electricity after using it, and please deal with it after confirming such electric discharge.
- [10] Protect against electric shocks by wearing insulated gloves when handling.

This evaluation board is intended for use only in research and development facilities and should be handled **only by qualified personnel familiar with all safety and operating procedures.**

We recommend carrying out operation in a safe environment that includes the use of high voltage signage at all entrances, safety interlocks, and protective glasses.

## Gate Driver

# BM60212FV-C Evaluation Board

## BM60212FV-EVK001

The BM60212FV-EVK001 board can be driving IGBT Power Devices for High-side and Low-side on Half-Bridge application. The BM60212FV-C has Power Supply protections which are the Under-Voltage Lockout (UVLO) function at VCCA and VCCB. The Active Miller Clamping is included for gate control. The BM60212FV-EVK001 allows designers to evaluate Rohm's Gate Driver family for various applications.

### Application

IGBT Gate Drive, MOSFET Gate Drive

### Electric Characteristics

Features and electric characteristics are complied with BM60212FV-C. The BM60212FV-C datasheet can be referenced to help facilitate designs.

### Operating Range

Parameter	Symbol	Min	Typ	Max	Units
High-side Floating Supply Voltage	V <sub>CCA</sub>	GND2+10	GND2+15	GND2+24	V
Low-side Supply Voltage	V <sub>CCB</sub>	10	15	24	V
Operating Temperature	T <sub>opr</sub>	-40		+125	°C

### Absolute Maximum Ratings

Parameter	Symbol	Limits	Units
High-side Floating Supply Voltage	V <sub>CCA</sub>	-0.3 to +1230.0 <sup>(Note 1)</sup>	V
Low-side Supply Voltage	V <sub>CCB</sub>	-0.3 to +30.0 <sup>(Note 1)</sup>	V
Logic Input Voltage (INA, INB, ENA)	V <sub>IN</sub>	-0.3 to +V <sub>CCB</sub> +0.3 or +30.0 <sup>(Note1)</sup>	V

(Note 1): Relative to GND1

Terminal Descriptions

Pin name	Description
VCCA	High-side power supply
VCCB	Low-side and input-side power supply
ENA	Input enabling signal input
INA	Control input pin for high-side
INB	Control input pin for low-side
GATE_L	Low-side Gate Control
GND1	Low-side and input-side ground
GND2	High-side ground
GATE_H	High-side Gate Control

Input / Output terminal Control

ENA (input)	INA (input)	INB (input)	GATE_H (Output)	GATE_L (Output)
L	X	X	L	L
H	L	L	L	L
H	L	H	L	H
H	H	L	H	L
H	H	H	L	L

X: Don't care

Waveform

When ENA = High:

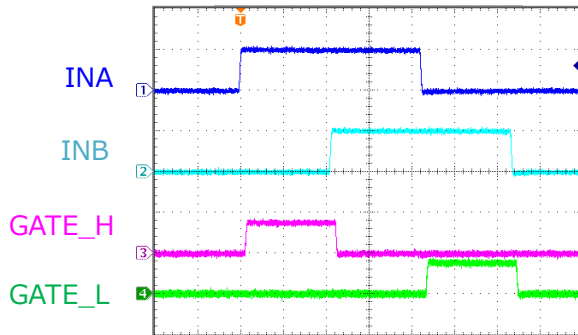

Evaluation Board

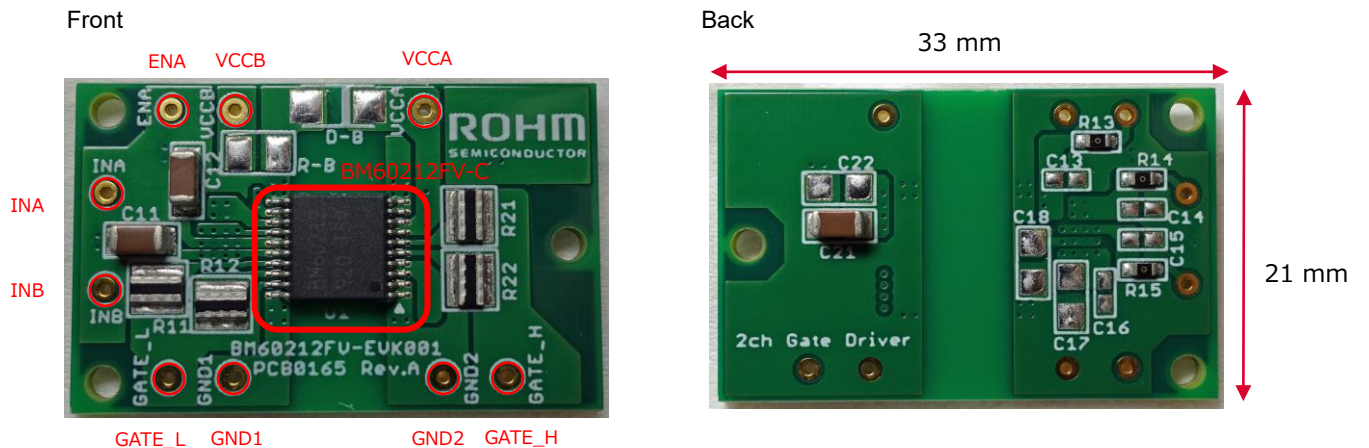

Schematics

R11, R12, R13, R14, R15, R21, and R22 are implemented interim resistors for shipment check. Please replace each resistor which can work with Power Device or input device appropriately.

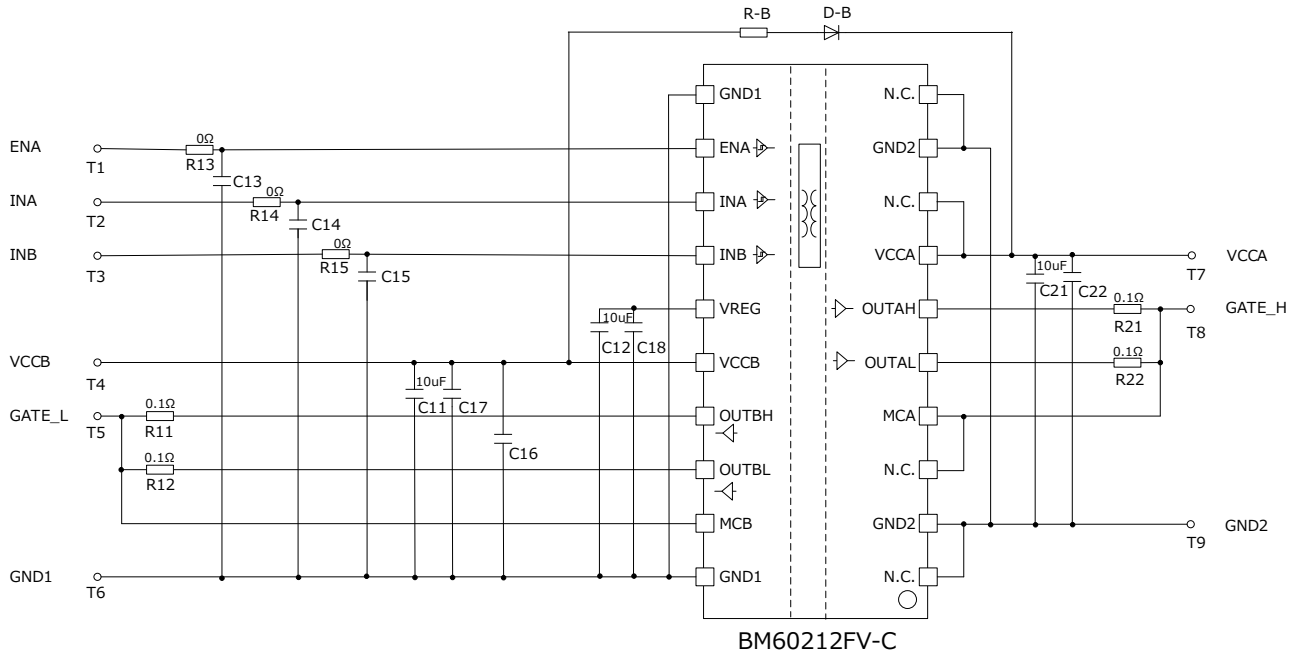

Bill of Materials

Device	Parts Number	Description	Manufacturer	Parts name	Qty.
Gate Driver	U1	2ch, 10-24V	ROHM	BM60212FV-C	1
Low-side and Input-side Capacitor	C11	10μF, 50V, X7R, 3216	TDK	CGA5L1X7R1H106K160	1
	C17	(no stuff)			0
High-side Capacitor	C21	10μF, 50V, X7R, 3216	TDK	CGA5L1X7R1H106K160	1
	C22	(no stuff)			0
VREG Capacitor	C12	10μF, 50V, X7R, 3216	TDK	CGA5L1X7R1H106K160	1
	C18	(no stuff)			0
Input signal filter	R13, R14, R15	0 ohm, 1608	ROHM	MCR03EZPJ000	3
	C13, C14, C15	(no stuff)			0
Low-side Gate	R11	0.1 ohm, 3216	ROHM	LTR18EZPJLR10	1
	R12	0.1 ohm, 3216	ROHM	LTR18EZPJLR10	1
High-side Gate	R21	0.1 ohm, 3216	ROHM	LTR18EZPJLR10	1
	R22	0.1 ohm, 3216	ROHM	LTR18EZPJLR10	1
Bootstrap	D-B	(no stuff)			0
	R-B	(no stuff)			0
Bypass	C16	(no stuff)			0
Test pin	T1, T2, T3, T4, T5, T6, T7, T8, T9 ( Option )	(no stuff)	Hirosugi-Keiki	HT-0710-3	9
Spacer	( Option )	M2, 10mm	Hirosugi-Keiki	BSN2010	3
Nut	( Option )	M2	Hirosugi-Keiki	NNT-00	3

Materials may be changed without notice.

### Application and Operation procedure

Following figure is shown the example application. IGBT [Power Device] and microcontroller [MCU] are connected to the board via terminals. VCCA power can be supplied from VCCB by using bootstrap circuit. Please place appropriate components on the EVK for bootstrap. Please make sure to replace the appropriate value for each resistor and capacitor on the board depends on your applications. The numerous application notes can be referenced to help facilitate designs. Useful application notes are listed on page 7.

#### Example Application

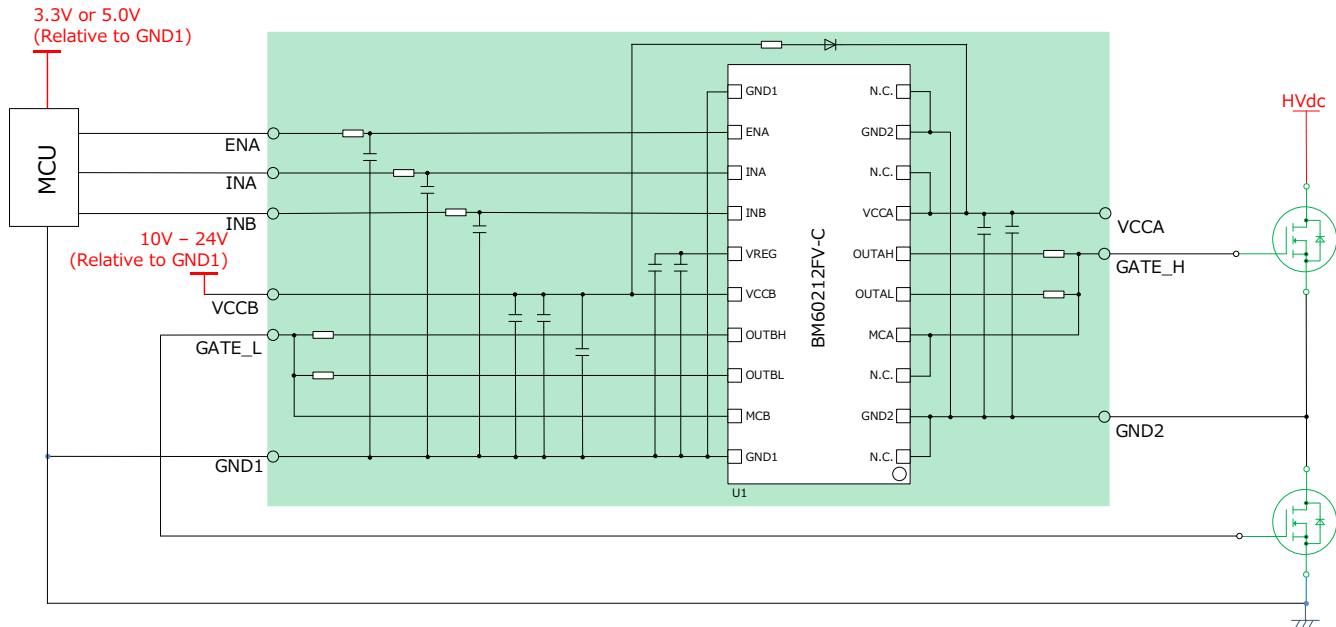

#### Additional Components for Bootstrapping

R-B and D-B parts are for bootstrapping. Place appropriate components depends on your applications.

Examples:

D-B: ROHM RFN2LAM6STF [Reverse voltage: 600V, Current: 1.5A, Package: PMDTM]

R-B: ROHM ESR18 series resistor [Package size: 3216mm]

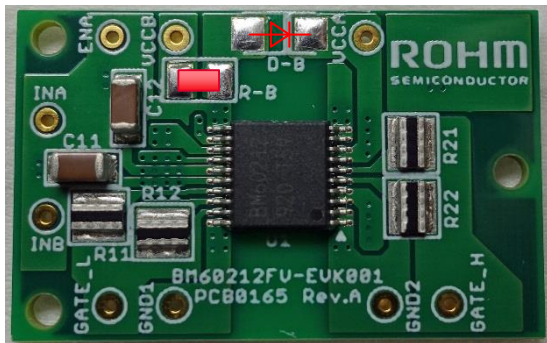

#### Equipment

- DC Power Supply: 5 V or 3.3V for control signal [5 VDC], 10 to 24 V for Power Device [10 to 24 VDC]
- Microcontroller [MCU]: Input signal for controlling GATE\_H and GATE\_L outputs
- Power Device: IGBT

We have many power devices which can work with Evaluation Board. You can get applicable product information from our web site. Some products are shown on page 7.

Instructions

Before start to connect, make sure to turn off all equipment for your safety.

1. Connect 5 VDC to VCC1-GND1 terminal on board.  
Stay turn off the power supply.
2. Connect 10 to 24 VDC to VCC2-GND2 terminal on board.  
Stay turn off the power supply.
3. Connect MCU to the ENA, INA, and INB terminal on board.  
Refer to the Input / Output terminal Control description on page 2.
4. Connect GATE\_H and GATE\_L terminal on board to gate terminals on high-side and low-side power devices.
5. Turn on the 5 VDC and MCU.
6. Turn on the 10 to 24 VDC.

**PCB Layout**

Board size: 33 x 21 mm, Material: FR-4, 4-layer.

Input-side capacitors and output capacitors [C16, C17, C18, C21, and C22] are placed on bottom side in order to reduce board size. When you design your PCB layout, we recommend to place them to the same side and near the gate driver as close as possible.

Top Layer with Pad and Silkscreen (Top View)

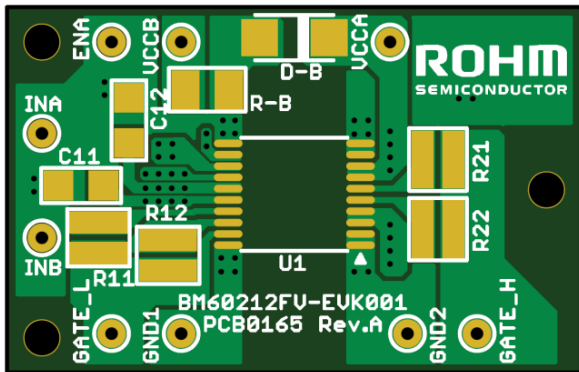

Bottom Layer with Pad and Silkscreen (Top View)

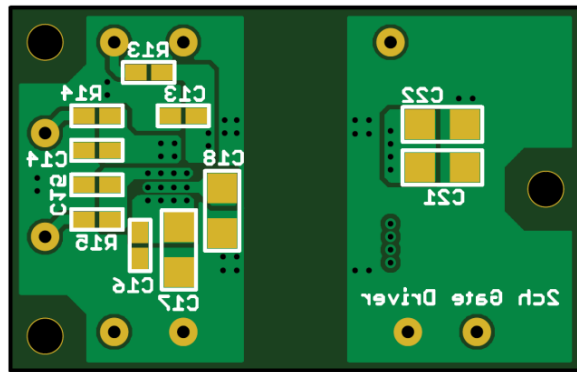

Top Layer (Top View)

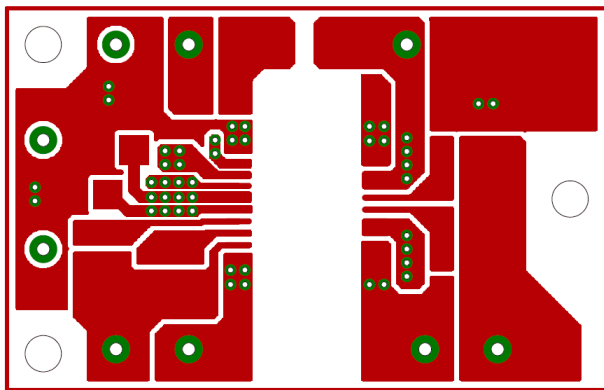

2<sup>nd</sup> Layer (Top View)

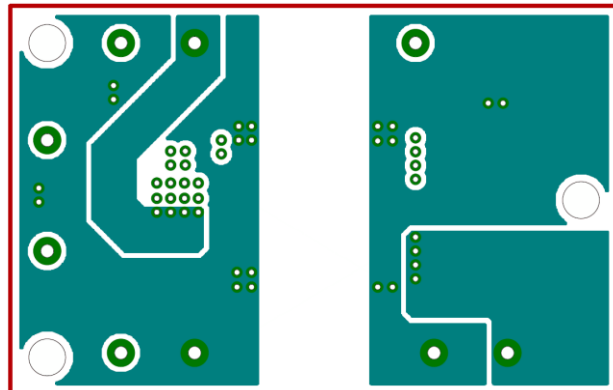

3<sup>rd</sup> Layer (Top View)

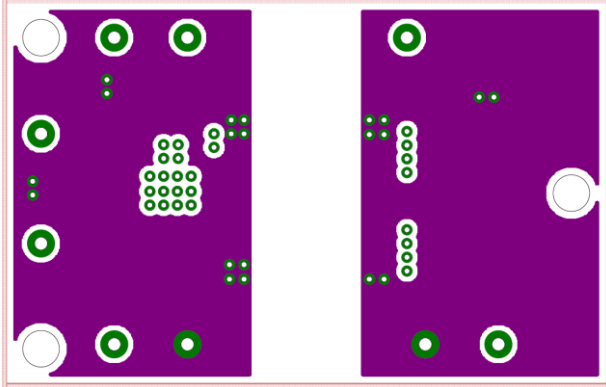

Bottom Layer (Top View)

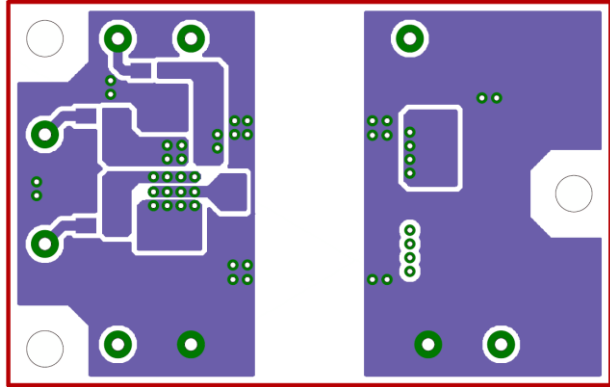

Silkscreen (Top)

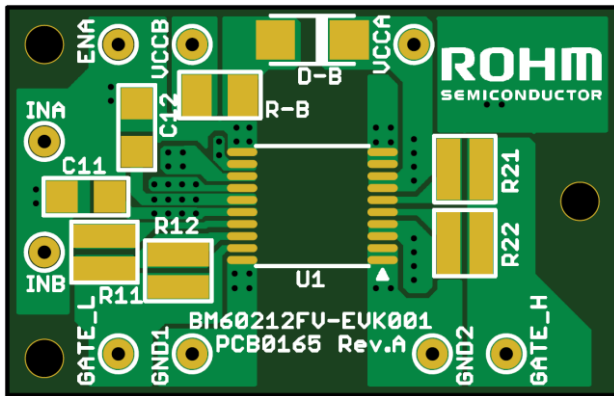

Silkscreen (Bottom)

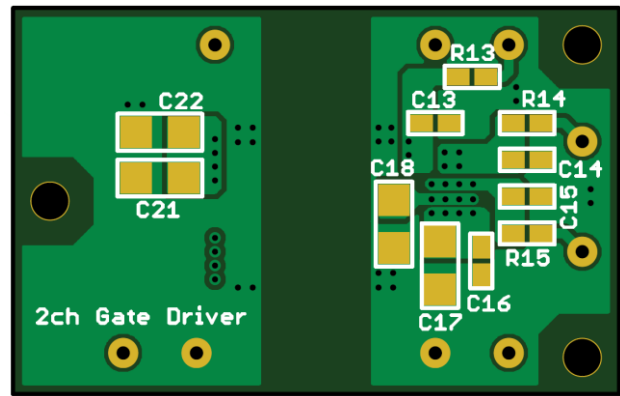



We have numerous power devices which are suitable for your requests.

For the IGBT, please visit our web site below:

<https://www.rohm.com/products/igbt>

Following examples are IGBT for high speed fast switching with fast recovery diode.

Matching Parts	V <sub>CES</sub> [V]	I <sub>c</sub> [A] (100°C)	V <sub>CE(SAT)</sub> (Typ.)[V]	tf(Typ.) [ns]	Diode	Package
RGW40TS65D	650	20	1.5	63	FRD	TO-247N
RGW50TS65D		25		53		
RGW60TS65D		30		35		
RGW80TS65D		40		34		
RGW00TS65D		50		33		
RGWX5TS65D		75		31		
RGW40TK65D		16		63		TO-3PFM
RGW50TK65D		18		53		
RGW60TK65D		20		35		
RGW80TK65D		23		34		
RGW80TK65E		23		34		
RGW00TK65D		26		33		

We also offer useful power device application notes for design and evaluation.

Please visit our web site below:

<https://www.rohm.com/search/application-notes>

1. Gate-source voltage behavior in a bridge configuration, No.60AN135E
2. Gate-Source Voltage Surge Suppression Methods, No.62AN010E
3. Snubber circuits design method for SiC MOSFET, No.62AN037E
4. Switching Loss improvement by TO-247-4L with Driver Source, No.62AN04E

**Revision History**

Date	Revision Number	Description
2019.10	001	

## Notes

- 1) The information contained herein is subject to change without notice.
- 2) Before you use our Products, please contact our sales representative and verify the latest specifications :
- 3) Although ROHM is continuously working to improve product reliability and quality, semiconductors can break down and malfunction due to various factors.  
Therefore, in order to prevent personal injury or fire arising from failure, please take safety measures such as complying with the derating characteristics, implementing redundant and fire prevention designs, and utilizing backups and fail-safe procedures. ROHM shall have no responsibility for any damages arising out of the use of our Products beyond the rating specified by ROHM.
- 4) Examples of application circuits, circuit constants and any other information contained herein are provided only to illustrate the standard usage and operations of the Products. The peripheral conditions must be taken into account when designing circuits for mass production.
- 5) The technical information specified herein is intended only to show the typical functions of and examples of application circuits for the Products. ROHM does not grant you, explicitly or implicitly, any license to use or exercise intellectual property or other rights held by ROHM or any other parties. ROHM shall have no responsibility whatsoever for any dispute arising out of the use of such technical information.
- 6) The Products specified in this document are not designed to be radiation tolerant.
- 7) For use of our Products in applications requiring a high degree of reliability (as exemplified below), please contact and consult with a ROHM representative : transportation equipment (i.e. cars, ships, trains), primary communication equipment, traffic lights, fire/crime prevention, safety equipment, medical systems, servers, solar cells, and power transmission systems.
- 8) Do not use our Products in applications requiring extremely high reliability, such as aerospace equipment, nuclear power control systems, and submarine repeaters.
- 9) ROHM shall have no responsibility for any damages or injury arising from non-compliance with the recommended usage conditions and specifications contained herein.
- 10) ROHM has used reasonable care to ensure the accuracy of the information contained in this document. However, ROHM does not warrants that such information is error-free, and ROHM shall have no responsibility for any damages arising from any inaccuracy or misprint of such information.
- 11) Please use the Products in accordance with any applicable environmental laws and regulations, such as the RoHS Directive. For more details, including RoHS compatibility, please contact a ROHM sales office. ROHM shall have no responsibility for any damages or losses resulting non-compliance with any applicable laws or regulations.
- 12) When providing our Products and technologies contained in this document to other countries, you must abide by the procedures and provisions stipulated in all applicable export laws and regulations, including without limitation the US Export Administration Regulations and the Foreign Exchange and Foreign Trade Act.
- 13) This document, in part or in whole, may not be reprinted or reproduced without prior consent of ROHM.



Thank you for your accessing to ROHM product informations.  
More detail product informations and catalogs are available, please contact us.

**ROHM Customer Support System**

<http://www.rohm.com/contact/>

## X-ON Electronics

Largest Supplier of Electrical and Electronic Components

*Click to view similar products for [Power Management IC Development Tools](#) category:*

*Click to view products by [ROHM](#) manufacturer:*

Other Similar products are found below :

[EVAL-ADM1168LQEBZ](#) [EVB-EP5348UI](#) [MIC23451-AAAYFL EV](#) [MIC5281YMME EV](#) [DA9063-EVAL](#) [ADP122-3.3-EVALZ](#) [ADP130-0.8-EVALZ](#) [ADP130-1.2-EVALZ](#) [ADP130-1.5-EVALZ](#) [ADP130-1.8-EVALZ](#) [ADP1712-3.3-EVALZ](#) [ADP1714-3.3-EVALZ](#) [ADP1715-3.3-EVALZ](#) [ADP1716-2.5-EVALZ](#) [ADP1740-1.5-EVALZ](#) [ADP1752-1.5-EVALZ](#) [ADP1828LC-EVALZ](#) [ADP1870-0.3-EVALZ](#) [ADP1871-0.6-EVALZ](#) [ADP1873-0.6-EVALZ](#) [ADP1874-0.3-EVALZ](#) [ADP1882-1.0-EVALZ](#) [ADP199CB-EVALZ](#) [ADP2102-1.25-EVALZ](#) [ADP2102-1.875EVALZ](#) [ADP2102-1.8-EVALZ](#) [ADP2102-2-EVALZ](#) [ADP2102-3-EVALZ](#) [ADP2102-4-EVALZ](#) [ADP2106-1.8-EVALZ](#) [ADP2147CB-110EVALZ](#) [AS3606-DB](#) [BQ24010EVM](#) [BQ24075TEVM](#) [BQ24155EVM](#) [BQ24157EVM-697](#) [BQ24160EVM-742](#) [BQ24296MEVM-655](#) [BQ25010EVM](#) [BQ3055EVM](#) [NCV891330PD50GEVB](#) [ISLUSBI2CKIT1Z](#) [LM2744EVAL](#) [LM2854EVAL](#) [LM3658SD-AEV/NOPB](#) [LM3658SDEV/NOPB](#) [LM3691TL-1.8EV/NOPB](#) [LM4510SDEV/NOPB](#) [LM5033SD-EVAL](#) [LP38512TS-1.8EV](#)