

DC / DC converter for LCDs

BP5302A / BP5302XA

The BP5302A and BP5302XA are DC / DC converters for supplying power to liquid crystal display (LCD) panels. The modules supply a negative voltage from a positive power supply. They are available in a single in-line package as an upright (BP5302A) or L-shaped lead (BP5302XA) type.

● Applications

LCD panels in personal computers and word processors

● Features

- 1) Wide input voltage range. (+5V to +14V)
- 2) High accurate output voltage. ($-24\pm 0.75V$)
- 3) High conversion efficiency. (Typ. 80%)
- 4) Built-in protection circuit.
- 5) Built-in ON/OFF switch.
- 6) Compact and light.
- 7) Available as an upright or L-shaped lead type.

● Absolute maximum ratings (Ta=25°C)

Parameter	Symbol	Limits	Unit
Input voltage	V _{IN}	15	V
Operating temperature range	Topr	0~60	°C
Storage temperature range	Tstg	-30~85	°C

● Electrical characteristics

(Unless otherwise noted: Ta=25°C, and R1 and R2 resistors in the measurement circuit of Fig.1 are disconnected)

Parameter	Symbol	Min.	Typ.	Max.	Unit	Conditions
Input voltage	V _{IN}	5	–	14	V	
Output current	I _{OUT}	–	–	30	mA	
Output voltage	V _{OUT}	-23.25	-24.00	-24.75	V	V _{IN} =12V, I _{OUT} =20mA
Line regulation	DV1	–	–	0.75	V	V _{IN} =5~14V, I _{OUT} =20mA
Load regulation	DV2	–	–	0.5	V	V _{IN} =12V, I _{OUT} =0~20mA
Ripple nose voltage	n1	–	–	200	mV _{P.P}	V _{IN} =12V, I _{OUT} =20mA *
Efficiency	h	70	80	-	%	V _{IN} =12V, I _{OUT} =20mA
ON / OFF CTL vottage when ON	V _{CTL}	1.5	–	6.0	V	V _{IN} =5~14V
ON / OFF CTL vottage when OFF	V _{CTL}	–	–	0.5	V	V _{IN} =5~14V (Alternatively, when OPEN)
ON / OFF CTL current	I _{CTL}	–	–	150	μA	V _{IN} =5~14V, V _{CTL} =5V
Current consumption when OFF	I _{OFF}	–	–	10	μA	V _{IN} =5~14V, V _{CTL} =0V
R1 resistance	R1	50	–	∞	kΩ	V _{IN} =5~14V, V _{CTL} =5V
R2 resistance	R2	20	–	∞	kΩ	V _{IN} =5~14V, V _{CTL} =5V

* Measured with a band width of 20MHz.

● Pin descriptions

Pin No.	Pin name	Function
1	C _o	Output smoothing capacitor connection pin; connect a low-impedance capacitor with a recommended capacitance of 47 μ F between this pin and GND
2	V _{OUT}	Output pin
3	V _{ref}	Output voltage adjustment pin for contrast; output voltage is adjusted by connecting a resistor between pins 2 and 3 or pins 3 and 4
4, 7	GND	Ground pin
8	V _{CTL}	Output ON / OFF control pin; output starts when the pin is HIGH level, and stops when the pin is LOW or OPEN
9	V _{IN}	Input pin; connect a low-impedance capacitor with a recommended capacitance of 100 μ F between this pin and GND

● Measurement circuit and Application example

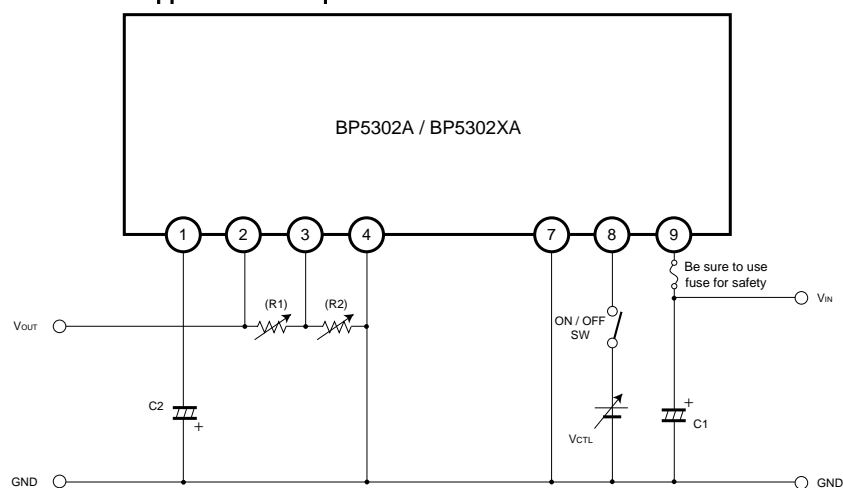

Fig.1

C1 : 100 μ F / 16V (Low impedance)
 C2 : 47 μ F / 35V (Low impedance)
 R1, R2 : Resistors for adjusting output voltage
 (Disconnected during test measurement)

● Operation notes

- (1) Place I/O external capacitors as near as possible to the connection pins. In particular, make sure to minimize the impedance between the input-side capacitor (C1) and pin 9. (Reference value: A length less than 50mm is recommended for a copper foil of 1.0mm wide and 35 μ F thick.)
- (2) Avoid frequent switching using the ON/OFF CTL pin (5 times per second at the maximum).
- (3) R1 and R2 resistors, which are used for changing the output voltage, are usually not required.

● Electrical characteristic curves

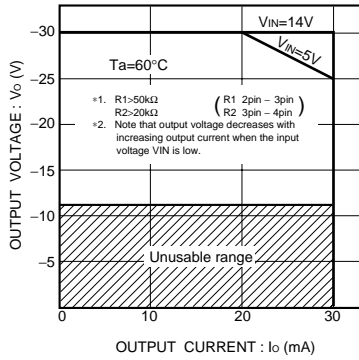

Fig.2 Derating curve

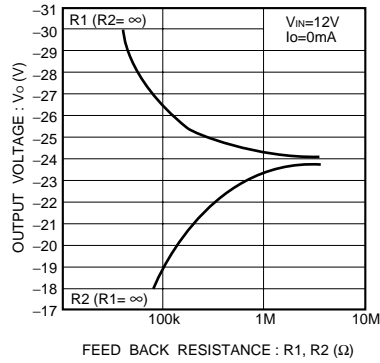

Fig.3 Output voltage vs. Feedback resistance (R1, R2)

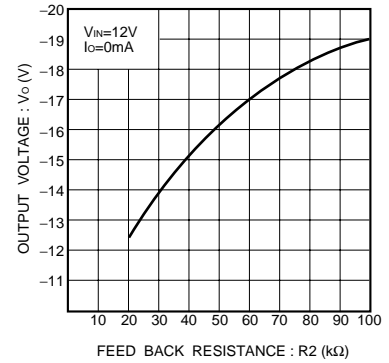
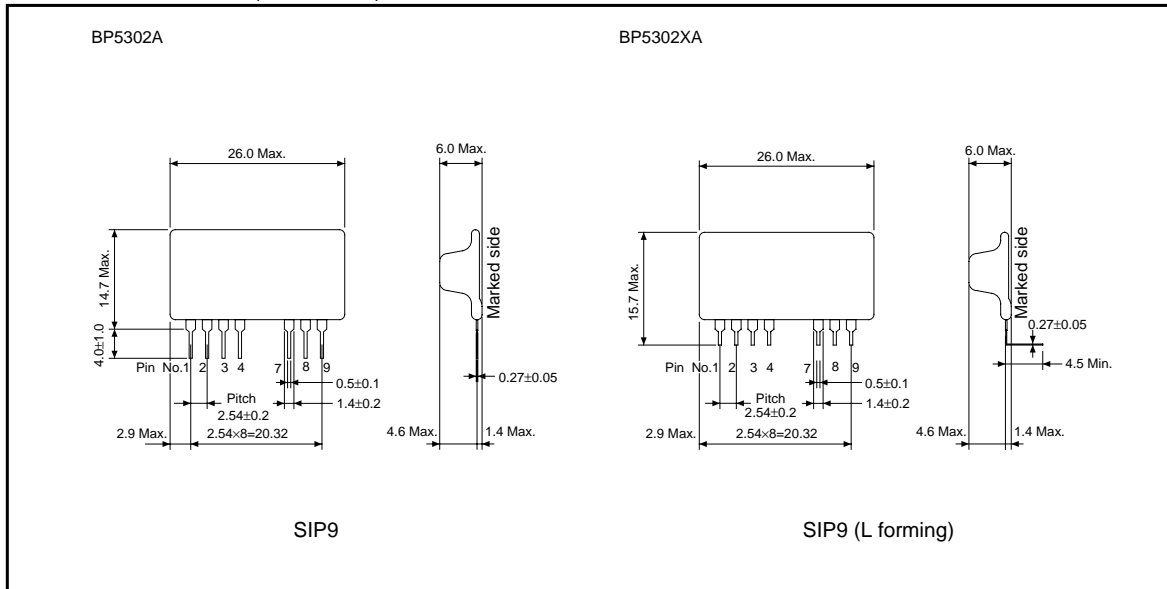

Fig.4 Output voltage vs. Feedback resistance (R2 < 100kΩ)

● External dimensions (Units : mm)



Precautions on Use of ROHM Power Module

Safety Precautions

- 1) The products are designed and produced for application in ordinary electronic equipment (AV equipment, OA equipment, telecommunication equipment, home appliances, amusement equipment etc.).
If the products are to be used in devices requiring extremely high reliability (medical equipment, transport equipment, aircraft/spacecraft, nuclear power controllers, fuel controllers, car equipment including car accessories, safety devices, etc.) and whose malfunction or operational error may endanger human life and sufficient fail-safe measures, please consult with the Company's sales staff in advance. If product malfunctions may result in serious damage, including that to human life, sufficient fail-safe measures must be taken, including the following:
 - [a] Installation of protection circuits or other protective devices to improve system safety
 - [b] Installation of redundant circuits in the case of single-circuit failure
- 2) The products are designed for use in a standard environment and not in any special environments. Application of the products in a special environment can deteriorate product performance. Accordingly, verification and confirmation of product performance, prior to use, is recommended if used under the following conditions:
 - [a] Use in various types of liquid, including water, oils, chemicals, and organic solvents
 - [b] Use outdoors where the products are exposed to direct sunlight, or in dusty places
 - [c] Use in places where the products are exposed to sea winds or corrosive gases, including Cl₂, H₂S, NH₃, SO₂, and NO₂
 - [d] Use in places where the products are exposed to static electricity or electromagnetic waves
 - [e] Use in proximity to heat-producing components, plastic cords, or other flammable items
 - [f] Use involving sealing or coating the products with resin or other coating materials
 - [g] Use involving unclean solder or use of water or water-soluble cleaning agents for cleaning after soldering
 - [h] Use of the products in places subject to dew condensation
- 3) The products are not radiation resistant.
- 4) The Company is not responsible for any problems resulting from use of the products under conditions not recommended herein.
- 5) The Company should be notified of any product safety issues. Moreover, product safety issues should be periodically monitored by the customer.

Precautions Regarding Application Example and External Circuits

- 1) If change is made to the constant of an external circuit, allow a sufficient margin due to variations of the characteristics of the products and external components, including transient characteristics, as well as static characteristics. Please be informed that the Company has not conducted investigations on whether or not particular changes in the application examples or external circuits would result in the infringement of patent rights of a third party.
- 2) The application examples, their constants, and other types of information contained herein are applicable only when the products are used in accordance with standard methods.
Therefore, if mass production is intended, sufficient consideration to external conditions must be made.

Prohibitions Regarding Industrial Property

- 1) These Specifications contain information related to the Company's industrial property. Any use of them other than pertaining to the usage of appropriate products is not permitted. Duplication of these Specifications and its disclosure to a third party without the Company's permission is prohibited.
- 2) Information and data on products, including application examples, contained in these specifications are simply for reference; the Company does not guarantee any industrial property rights, intellectual property rights, or any other rights of a third party regarding this information or data. Accordingly, the Company does not bear any responsibility for:
 - [a] infringement of the intellectual property rights of a third party
 - [b] any problems incurred by the use of the products listed herein.
- 3) The Company prohibits the purchaser of its products to exercise or use the intellectual property rights, industrial property rights, or any other rights that either belong to or are controlled by the Company, other than the right to use, sell, or dispose of the products.

X-ON Electronics

Largest Supplier of Electrical and Electronic Components

Click to view similar products for [Switching Voltage Regulators](#) category:

Click to view products by [ROHM](#) manufacturer:

Other Similar products are found below :

[FAN53610AUC33X](#) [FAN53611AUC123X](#) [FAN48610BUC33X](#) [FAN48610BUC45X](#) [FAN48617UC50X](#) [R3](#) [430464BB](#) [KE177614](#)
[MAX809TTR](#) [NCV891234MW50R2G](#) [NCP81103MNTXG](#) [NCP81203PMNTXG](#) [NCP81208MNTXG](#) [NCP81109GMNTXG](#)
[SCY1751FCCT1G](#) [NCP81109JMNTXG](#) [AP3409ADNTR-G1](#) [NCP81241MNTXG](#) [LTM8064IY](#) [LT8315EFE#TRPBF](#) [LTM4668AIY#PBF](#)
[NCV1077CSTBT3G](#) [XCL207A123CR-G](#) [MPM54304GMN-0002](#) [MPM54304GMN-0003](#) [XDPE132G5CG000XUMA1](#) [MP8757GL-P](#)
[MP9943AGQ-P](#) [MIC23356YFT-TR](#) [LD8116CGL](#) [HG2269M/TR](#) [OB2269](#) [XD3526](#) [U6215A](#) [U6215B](#) [U6620S](#) [LTC3412IFE](#) [LT1425IS](#)
[MAX25203BATJA/VY+](#) [MAX77874CEWM+](#) [XC9236D08CER-G](#) [ISL95338IRTZ](#) [MP3416GJ-P](#) [BD9S201NUX-CE2](#) [MP5461GC-Z](#)
[MPQ4415AGQB-Z](#) [MPQ4590GS-Z](#) [MCP1603-330IMC](#) [MCP1642B-18IMC](#) [MCP1642D-ADJIMC](#)