

12-bit, serial IN, parallel OUT driver

BU2090 / BU2090F / BU2090FS / BU2092 / BU2092F / BU2092FV

The BU2090, BU2090F, BU2090FS, BU2092, BU2092F, and BU2092FV are 12-bit serial input, parallel output drivers.

For the BU2090 / F / FS, data input is shifted to the 12-bit internal shift register on the rising edge of a clock pulse. On the falling edge of the pulse, if the DATA pin is HIGH, the data in the shift register is output in parallel to Q0 to Q11.

For the BU2092 / F / FV, shift data read at the rising edge of CLOCK is output in parallel to Q0 to Q11 at the rising edge of LCK. These ICs also have an OE pin, which when HIGH, forces data to be output, regardless of the shift data state.

●Applications

Radio cassette players, telephones, compact audio systems, car stereos, and others

●Features

- 1) Low power dissipation.
- 2) Operating voltages ranging from 2.7 to 5.5V.
- 3) Output is Nch open drain.
- 4) High output withstand voltage of + 25V.
- 5) Diverse variety of packages.
BU2090 / F / FS: DIP16, SOP16, SSOP-A16
BU2092 / F / FV: DIP18, SOP18, SSOP-A18
(plastic molds)
- 6) High drive capability; direct lighting of green LED possible.

● Absolute maximum ratings (Ta = 25°C)
(BU2090 / F / FS, BU2092 / F / FV)

Parameter		Symbol	Limits	Unit
Power supply voltage		V _{DD}	- 0.3 ~ + 7.0	V
Power dissipation	BU2090 / F / FS	P _d	1000 (DIP), 300 (SOP), 500 (SSOP)*1	mW
	BU2092 / F / FV		1050 (DIP), 450 (SOP), 400 (SSOP)*1	
Power dissipation	BU2090 / F / FS	P _d	500 (SOP)*2, 650 (SSOP)*3	mW
	BU2092 / F / FV		500 (SOP)*2, 650 (SSOP)*4	
Operating temperature		T _{opr}	- 25 ~ + 75	°C
Storage temperature		T _{stg}	- 55 ~ + 125	°C
Input voltage		V _{IN}	V _{SS} - 0.3 ~ V _{DD} + 0.3	V
Output voltage		V _O	V _{SS} ~ 25.0	V

*1 Unmounted

*2 When mounted on a glass epoxy board of 50mm × 50mm × 1.6mm

*3 When mounted on a glass epoxy board of 90mm × 50mm × 1.6mm

*4 When mounted on a glass epoxy board of 70mm × 70mm × 1.6mm

● Recommended operating conditions

Parameter	Symbol	Limits	Unit
Power supply voltage	V _{DD}	2.7 ~ 5.5	V

●Block diagram

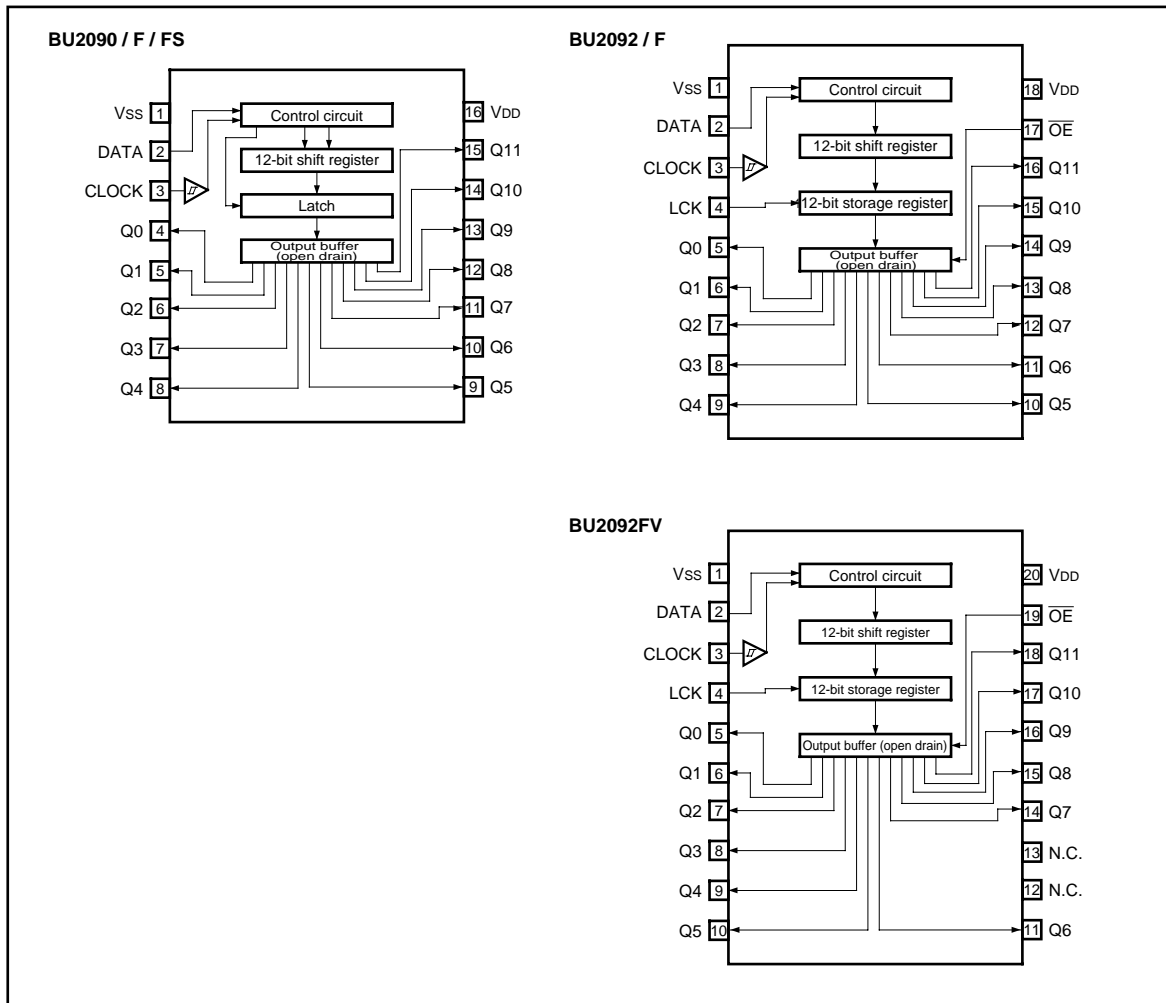

●Pin descriptions

Pin No.			Pin name	Function
BU2090 / F / FS	BU2092 / F	BU2092 / FV		
1	1	1	V _{SS}	GND
2	2	2	DATA	Serial data input
3	3	3	CLOCK	Data shift clock input
—	4	4	LCK	Data latch clock input
4	5	5	Q0	Parallel data output
5	6	6	Q1	Parallel data output
6	7	7	Q2	Parallel data output
7	8	8	Q3	Parallel data output
8	9	9	Q4	Parallel data output
9	10	10	Q5	Parallel data output
10	11	11	Q6	Parallel data output
—	—	12	N.C.	Not connected
—	—	13	N.C.	Not connected
11	12	14	Q7	Parallel data output
12	13	15	Q8	Parallel data output
13	14	16	Q9	Parallel data output
14	15	17	Q10	Parallel data output
15	16	18	Q11	Parallel data output
—	17	19	$\overline{\text{OE}}$	Output Enable
16	18	20	V _{DD}	Power supply

●Electrical characteristics (Ta = 25°C)

DC characteristics (unless otherwise noted, Ta = 25°C, Vss = 0V)

Parameter	Symbol	Min.	Typ.	Max.	Unit	VDD	Conditions
Input high level voltage	VIH	3.5	—	—	V	5	—
		2.5	—	—		3	
Input low level voltage	VIL	—	—	1.5	V	5	—
		—	—	0.4		3	
Output low level voltage	VOL	—	—	2.0	V	5	IoL = 20mA
		—	—	1.0		3	IoL = 5mA
"H" output disable current	IoZH	—	—	10.0	μA	5	Vo = 25.0V
"L" output disable current	IoZL	—	—	- 5.0	μA	5	Vo = 0V
Current dissipation	IDD	—	—	5.0	μA	5	VIN = Vss or VDD
		—	—	3.0		3	OUTPUT: OPEN

BU2090 / F / FS switching characteristics (unless otherwise noted, Ta = 25°C, Vss = 0V)

Parameter	Symbol	Min.	Typ.	Max.	Unit	VDD	Conditions
Minimum clock pulse width	tw	500	—	—	ns	5	—
		1000	—	—		3	
Data shift setup time	tsu	200	—	—	ns	5	—
		300	—	—		3	
Data shift hold time	th	200	—	—	ns	5	—
		400	—	—		3	
Data latch setup time	tLSUH	50	—	—	ns	5	—
		100	—	—		3	
Data latch hold time	tLHH	250	—	—	ns	5	—
		500	—	—		3	
Data latch "L" setup time	tLSUL	200	—	—	ns	5	—
		400	—	—		3	
Data latch "L" hold time	tLHL	250	—	—	ns	5	—
		500	—	—		3	

○Not designed for radiation resistance.

BU2090 / F / FS switching characteristics measurement conditions

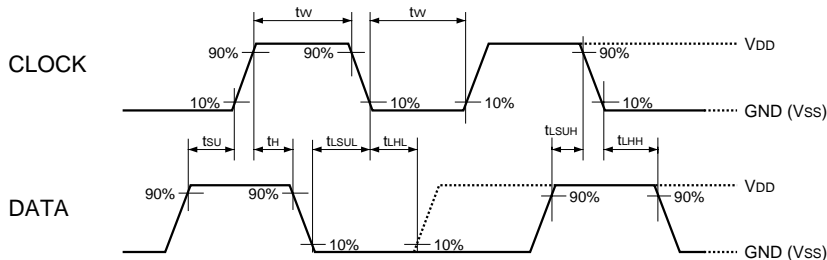

Fig.1

BU2092 / F / FV switching characteristics (unless otherwise noted, Ta = 25°C, Vss = 0V)

Parameter	Symbol	Min.	Typ.	Max.	Unit	V _{DD}	Conditions
Transmission delay time (LCK to OUTPUT QX)	t _{PLZ (LCK)}	—	55	—	ns	5	R _L = 5kΩ C _L = 10pF
		—	90	—		3	
	t _{PZL (LCK)}	—	50	—	ns	5	
		—	115	—		3	
Output disable time (OE to OUTPUT QX)	t _{PLZ}	—	45	—	ns	5	R _L = 5kΩ C _L = 10pF
		—	70	—		3	
	t _{PZL}	—	35	—	ns	5	
		—	80	—		3	
Minimum clock pulse width	t _w	500	—	—	ns	5	—
		1000	—	—		3	
Minimum latch pulse width	t _{w (LCK)}	500	—	—	ns	5	—
		1000	—	—		3	
Setup time (LCK to CLOCK)	t _s	200	—	—	ns	5	—
		400	—	—		3	
Setup time (DATA to CLOCK)	t _{su}	200	—	—	ns	5	—
		400	—	—		3	
Hold time (CLOCK to DATA)	t _h	200	—	—	ns	5	—
		400	—	—		3	

○ Not designed for radiation resistance.

BU2092 / F / FV switching characteristics measurement conditions

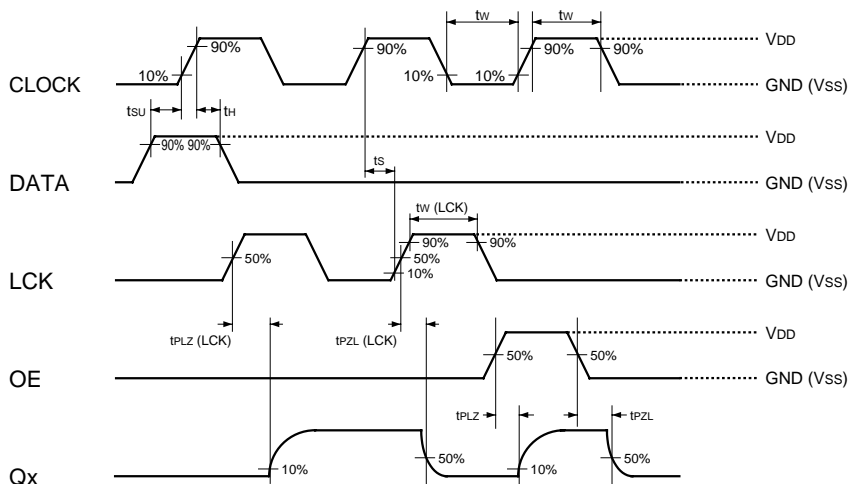







Fig.2

● Truth table

BU2092 / F / FV

INPUT				FUNCTION
CLOCK	DATA	LCK	OE	
×	×	×	H	Output (Q0 to Q11) disabled
×	×	×	L	Output (Q0 to Q11) enabled
	L	×	×	First cell of the shift register stores the LOW. Other cells, respectively, store data from the preceding cells or other prior data. (Output state is HOLD.)
	H	×	×	First cell of the shift register stores the HIGH. Other cells, respectively, store data from the preceding cells or other prior data. (Storage state and output state are HOLD.)
	×	×	×	No change in shift register.
×	×		×	Contents of shift register are stored in storage register.
×	×		×	No change in shift register.

Q0 to Q11 output for the BU2090 / F / FS and BU2092 / F / FV is Nch open drain output. When the shift register transfer data is LOW, the corresponding output FET is ON (continuous state). When the transfer data is HIGH, the output FET is OFF (discontinuous).

● Input / output circuit

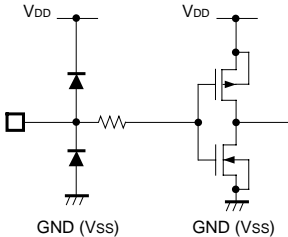
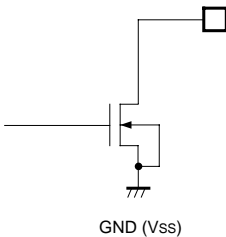
BU2090 / F / FS		BU2092 / F		BU2092FV		BU2090 / F / FS		BU2092 / F		BU2092FV	
Pin No.	2, 3	Pin No.	2, 3, 4, 17	Pin No.	2, 3, 4, 19	Pin No.	4, 5, 6, 7, 8, 9, 10, 11, 12, 13, 14, 15	Pin No.	5, 6, 7, 8, 9, 10, 11, 12, 13, 14, 15, 16	Pin No.	5, 6, 7, 8, 9, 10, 11, 14, 15, 16, 17, 18
											

●Circuit operation

The logic of the DATA pin is sent to the 12-bit shift register on the rising edge of the CLOCK pulse. Subsequently, it is shifted from Q0 to Q11 for every clock rising edge.

For the BU2090 / F / FS

When the DATA pin is LOW on the CLOCK falling edge, the data does not change its output state. It is only shifted in the internal shift register. However, when the DATA pin is HIGH, the content of the 12-bit shift register is latched and is output to the corresponding Q0 to Q11.

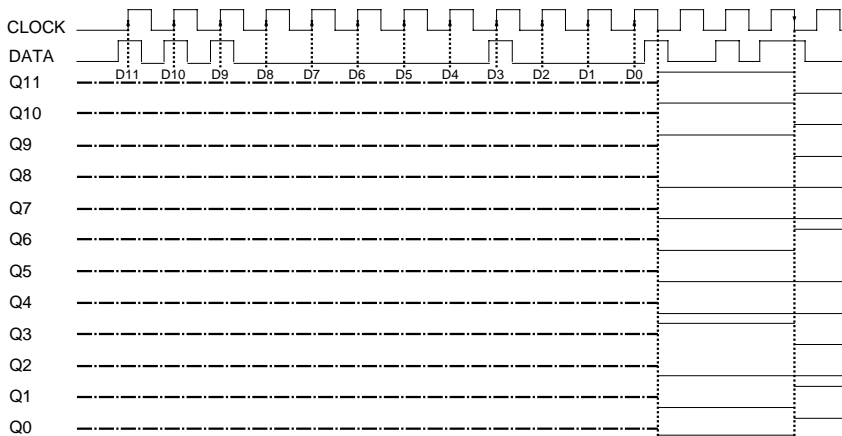

Note 1) ——— indicates unstable output.

Note 2) Pull-up resistance is connected to the output pin.

Fig.3 Operation timing chart

For the BU2092 / F / FV

The content of the 12-bit shift register is stored in the 12-bit storage register at the rising edge of LCK, and is output to the corresponding Q0 to Q11. When OE is HIGH, regardless of the content of the storage register, the output FET turns OFF and enters a HIGH (discontinuous) state.

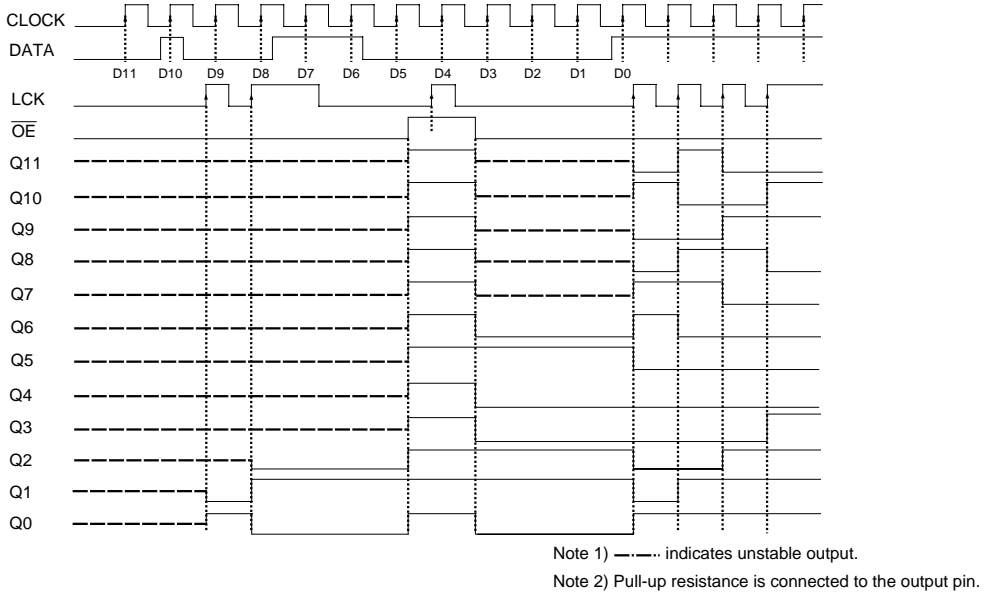

Fig.4 Operation timing chart

●Application example
BU2090 / F / FS

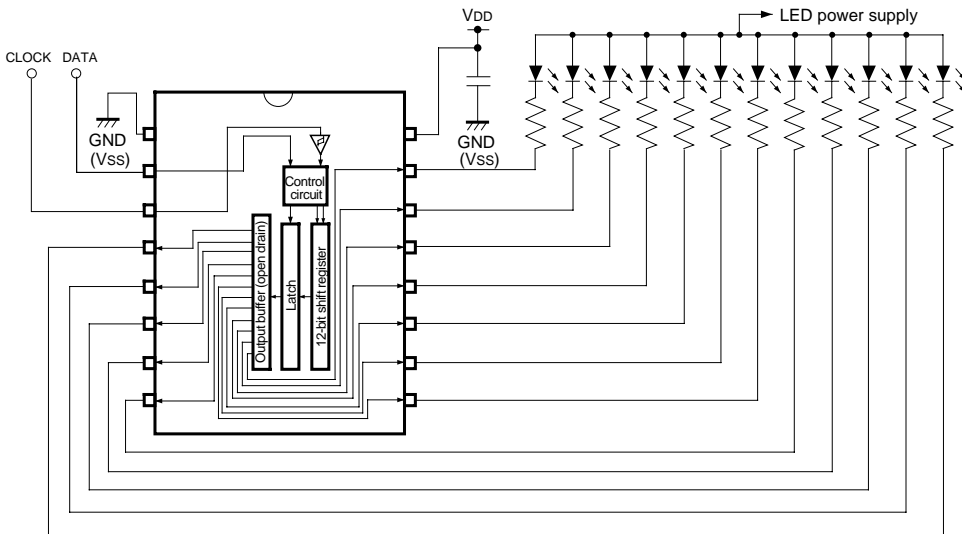

Fig.5

BU2092 / F / (FV)

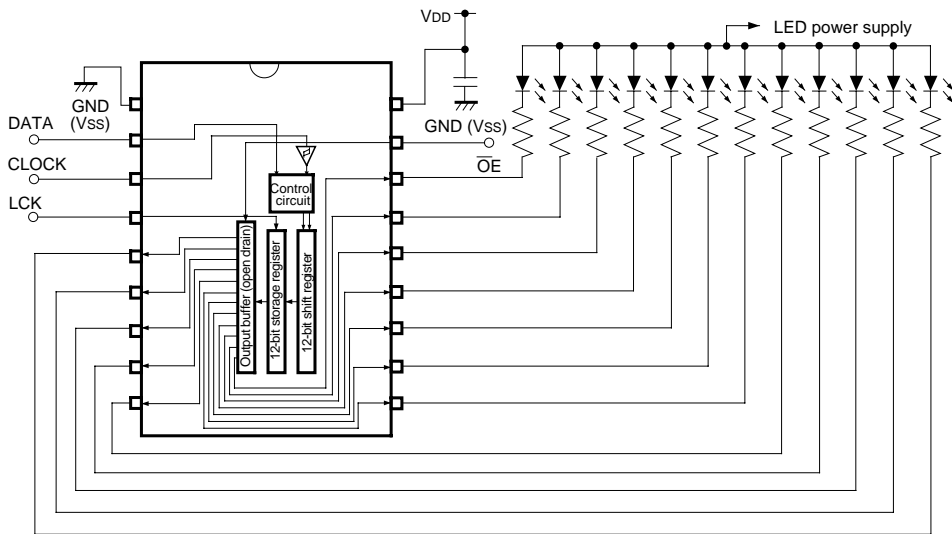

Fig.6

●Electrical characteristic curves

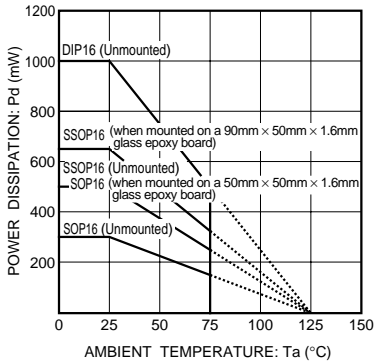

Fig.7 BU2090 / F / FS thermal derating characteristics

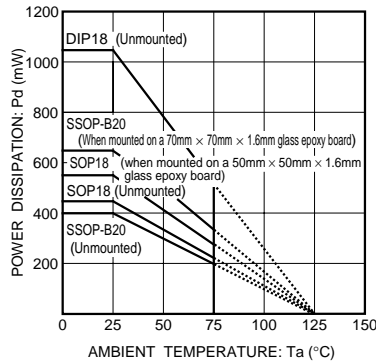

Fig.8 BU2092 / F / FV thermal derating characteristics

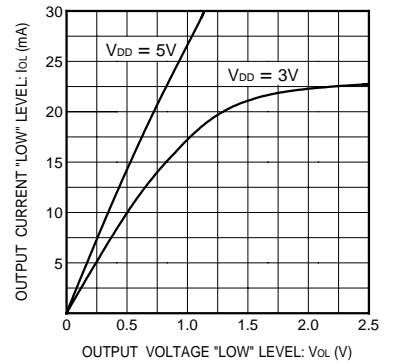
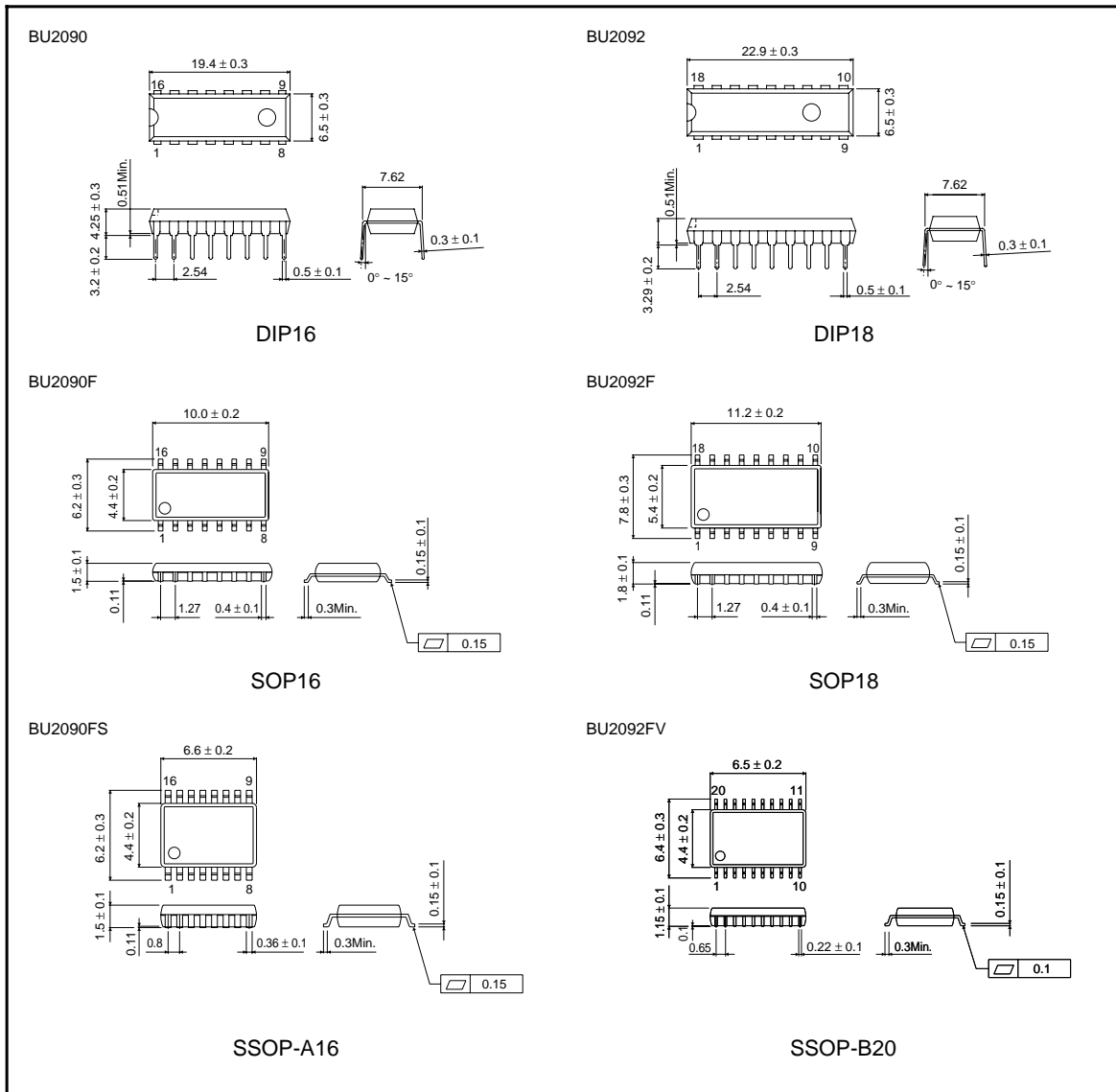

Fig.9 Output current vs.output low level voltage

●External dimensions (Units: mm)



X-ON Electronics

Largest Supplier of Electrical and Electronic Components

Click to view similar products for [Buffers & Line Drivers](#) category:

Click to view products by [ROHM](#) manufacturer:

Other Similar products are found below :

[LXV200-024SW](#) [74AUP2G34FW3-7](#) [HEF4043BP](#) [NLU1GT126CMUTCG](#) [PI74FCT3244L](#) [MC74HCT365ADTR2G](#) [Le87401NQC](#)
[Le87402MQC](#) [028192B](#) [042140C](#) [051117G](#) [070519XB](#) [NL17SZ07P5T5G](#) [NLU1GT126AMUTCG](#) [74AUP1G17FW5-7](#) [74LVC2G17FW4-7](#)
[CD4502BE](#) [5962-8982101PA](#) [5962-9052201PA](#) [74LVC1G125FW4-7](#) [NL17SH17P5T5G](#) [NL17SH125P5T5G](#) [NLV37WZ07USG](#)
[RHRXH162244K1](#) [74AUP1G34FW5-7](#) [74AUP1G07FW5-7](#) [74LVC2G126RA3-7](#) [NLX2G17CMUTCG](#) [74LVCE1G125FZ4-7](#) [Le87501NQC](#)
[74AUP1G126FW5-7](#) [TC74HC4050AP\(F\)](#) [74LVCE1G07FZ4-7](#) [NLX3G16DMUTCG](#) [NLX2G06AMUTCG](#) [NLVVHC1G50DFT2G](#)
[NLU2G17AMUTCG](#) [LE87100NQC](#) [LE87290YQC](#) [LE87290YQCT](#) [LE87511NQC](#) [LE87511NQCT](#) [LE87557NQC](#) [LE87557NQCT](#)
[LE87614MQC](#) [LE87614MQCT](#) [74AUP1G125FW5-7](#) [NLU2G16CMUTCG](#) [MC74LCX244MN2TWG](#) [NLV74VHC125DTR2G](#)