

8bit 12-channel D/A converter

BU2500FV / BU2501FV

BU2500FV / BU2501FV is a 12ch high-performance 8bit D/A converter which adopts the R-2R system. The BU2500FV utilizes a 5V supply voltage and the BU2501FV a 3V. Each channel output incorporates a Rail to Rail output type buffer amplifier. Three wire serial data input and cascade connection is possible. Small package (0.65mm pitch and 20pin) is adopted.

●Applications

CD-R, CD-RW, DVC, Digital camera and industrial equipment

●Features

- 1) High-performance 8bit 12-channel D/A converter adopting the R-2R system.
- 2) Output of each channel incorporates a Rail to Rail output type buffer amplifier.
- 3) Digital input compatible with TTL levels.
- 4) 12bit 3wire serial data input, cascade connection is possible.
- 5) Buffer amplifier of each channel is highly-stable. Prevents oscillation even with capacitance loads.

●Absolute maximum ratings (Ta=25°C)

Parameter	Symbol	Limits	Unit
Supply voltage	V _{CC}	-0.3~+6.0	V
Upper reference voltage of D/A converter	V _{DD}	-0.3~+6.0	V
Input voltage	V _{IN}	-0.3~+6.0	V
Output voltage	V _{OUT}	-0.3~+6.0	V
Power dissipation	P _d	400*	mW
Operating temperature	T _{opr}	-25~+85	°C
Storage temperature	T _{stg}	-55~+125	°C

* Reduced by 4mW for each increase in Ta of 1°C over 25°C.

●Recommended operating conditions (Ta=25°C)

Parameter	Symbol	Limits	Unit
Supply voltage (BU2500FV)	V _{CC}	4.5~5.5	V
Supply voltage (BU2501FV)	V _{CC}	2.7~3.6	V

Optical disc ICs

●Block diagram

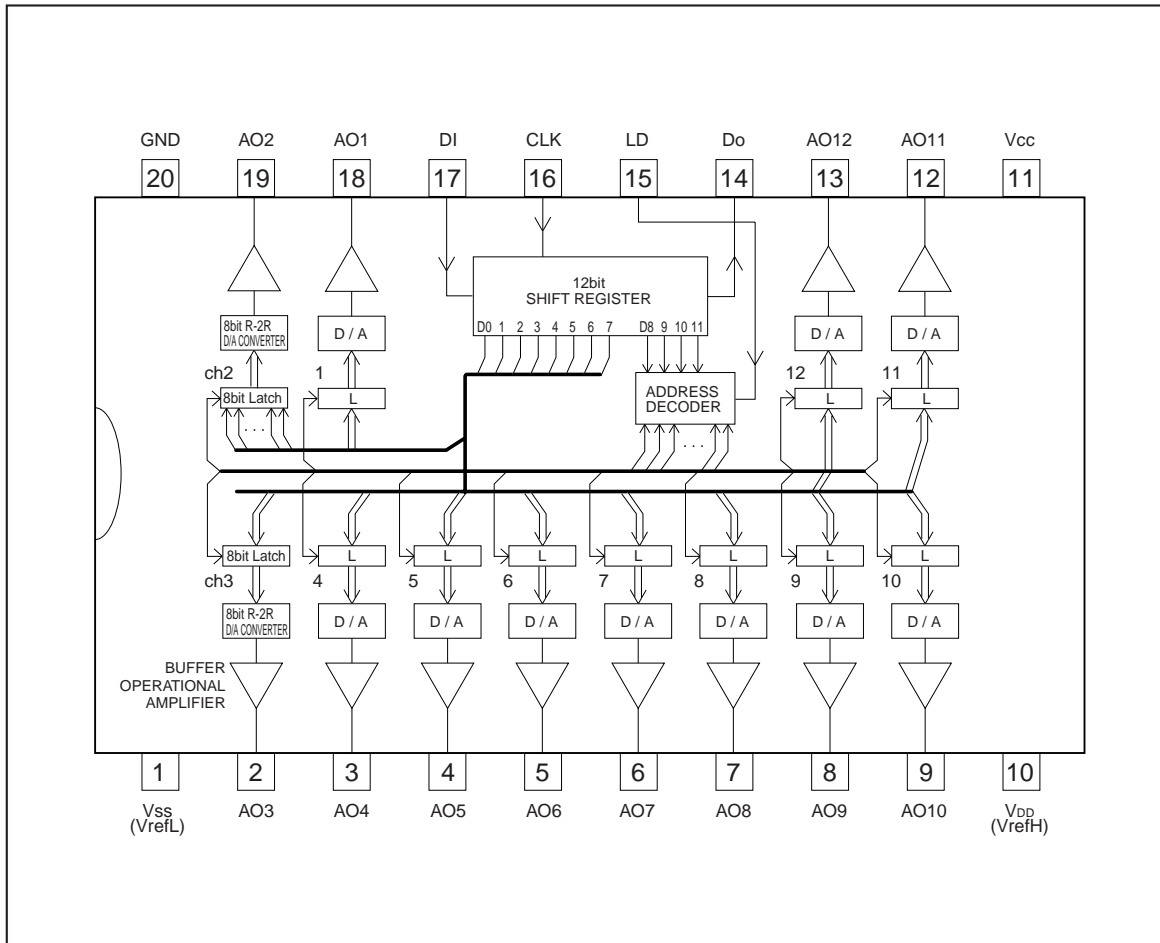

Optical disc ICs

●Pin descriptions

Pin No.	Pin name	Analog / Digital	I / O	Function	Circuit
1	Vss	Analog	–	D/A converter lower reference voltage input terminal	5
2	Ao3	Analog	O	8bit D/A converter output terminal (CH3)	3
3	Ao4	Analog	O	8bit D/A converter output terminal (CH4)	3
4	Ao5	Analog	O	8bit D/A converter output terminal (CH5)	3
5	Ao6	Analog	O	8bit D/A converter output terminal (CH6)	3
6	Ao7	Analog	O	8bit D/A converter output terminal (CH7)	3
7	Ao8	Analog	O	8bit D/A converter output terminal (CH8)	3
8	Ao9	Analog	O	8bit D/A converter output terminal (CH9)	3
9	Ao10	Analog	O	8bit D/A converter output terminal (CH10)	3
10	VDD	Analog	–	D/A converter upper reference voltage input terminal	4
11	Vcc	–	–	Power supply terminal	–
12	Ao11	Analog	O	8bit D/A converter output terminal (CH11)	3
13	Ao12	Analog	O	8bit D/A converter output terminal (CH12)	3
14	Do	Digital	O	Terminal to output MSB data of 12-bit shift register	2
15	LD	Digital	I	When H-level signal is input to this terminal, the value stored in 12-bit shift register is loaded in decoder and D/A converter output register.	1
16	CLK	Digital	I	Shift clock input terminal. Input signal at DI pin is input to 12-bit shift register at rise of shift clock pulse	1
17	DI	Digital	I	Serial data input terminal to input 12-bit long serial data	1
18	Ao1	Analog	O	8bit D/A converter output terminal (CH1)	3
19	Ao2	Analog	O	8bit D/A converter output terminal (CH2)	3
20	GND	–	–	GND terminal	–

●External dimensions (Unit : mm)

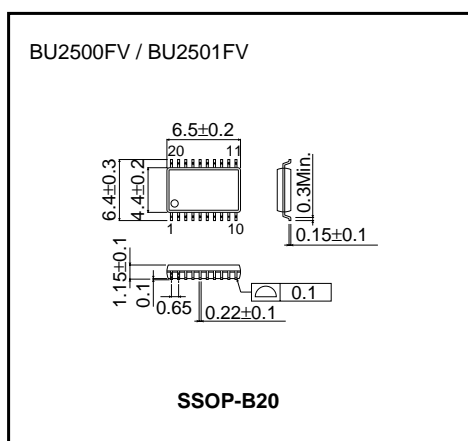

X-ON Electronics

Largest Supplier of Electrical and Electronic Components

Click to view similar products for [Digital to Analog Converters - DAC category](#):

Click to view products by [ROHM manufacturer](#):

Other Similar products are found below :

[5962-8871903MYA](#) [5962-8876601LA](#) [AD5311BRMZ-REEL7](#) [AD664AJ](#) [AD7534JPZ](#) [TCC-103A-RT](#) [057536E](#) [5962-89657023A](#)
[702423BB](#) [TCC-202A-RT](#) [AD664BE](#) [TCC-303A-RT](#) [TCC-206A-RT](#) [AD5770RBCBZ-RL7](#) [DAC8229FSZ-REEL](#) [AD5673RBCPZ-2](#)
[MCP48FVB24-20E/ST](#) [MCP48FVB28-E/MQ](#) [MCP48FEB18-20E/ST](#) [MCP48FEB18-E/MQ](#) [MCP48FEB24-E/MQ](#) [MCP48FEB28T-20E/ST](#)
[MCP47FVB04T-E/MQ](#) [MCP48FEB28T-E/MQ](#) [MCP48FVB28T-20E/ST](#) [MCP47FVB28T-20E/ST](#) [MCP47FEB24T-E/MQ](#) [MCP48FVB24T-](#)
[E/MQ](#) [MCP48FVB18T-20E/ST](#) [MCP47FEB14T-E/MQ](#) [MCP48FVB14T-20E/ST](#) [MCP48FEB08T-E/MQ](#) [MCP47FEB08T-E/MQ](#)
[MCP48FVB08T-20E/ST](#) [MCP48FEB04T-20E/ST](#) [MCP47FEB04T-E/MQ](#) [MCP48FVB04T-20E/ST](#) [MCP47FVB04T-20E/ST](#) [AD7524JRZ-](#)
[REEL](#) [LTC1664CGN](#) [LTC1664IGN](#) [LTC7545ACSW](#) [MCP47DA1T-A1E/OT](#) [MCP4921-E/MC](#) [UC3910D](#) [DAC39J84IAAV](#)
[DAC8218SPAG](#) [DAC8562TDGSR](#) [MAX551ACUB+](#) [MAX545BCPD+](#)