

Bi-directional VCM driver for Auto focus

BU64295GWZ BU64296GWX

General Description

The BU64295GWZ and BU64296GWX are designed to drive Bi-directional voice coil motors. Additionally the drivers are able to source the output current without the need for a direction control signal. The drivers include ISRC (intelligent slew rate control) to reduce mechanical ringing to optimize the camera's autofocus capabilities.

Key Specifications

■ Power Supply Range:	2.3V to 4.8V
■ Standby Current:	70µA (Typ)
■ Internal Resistance:	2.0Ω (Typ)
■ Master Clock:	2MHz (Typ)
■ Maximum Output Current:	+100mA, -100mA (Typ)
■ Temperature Range:	-25°C to +85°C

Features

- Bi-directional Constant Current Driver
- 10 bit Resolution Current Control
- ISRC Mechanical Ringing Compensation
- 2-wire Serial Interface (I²C compatible)
- Integrated Current Sense Resistor

Applications

- Mobile Camera Module
- Bi-directional VCM Actuators

Packages

■ BU64295GWZ	W (Typ) x D (Typ) x H (Max)
UCSP30L1	0.77mm x 1.2mm x 0.33mm
■ BU64296GWX	W (Typ) x D (Typ) x H (Max)
UCSP16X1	0.77mm x 1.2mm x 0.20mm

Typical Application Circuit

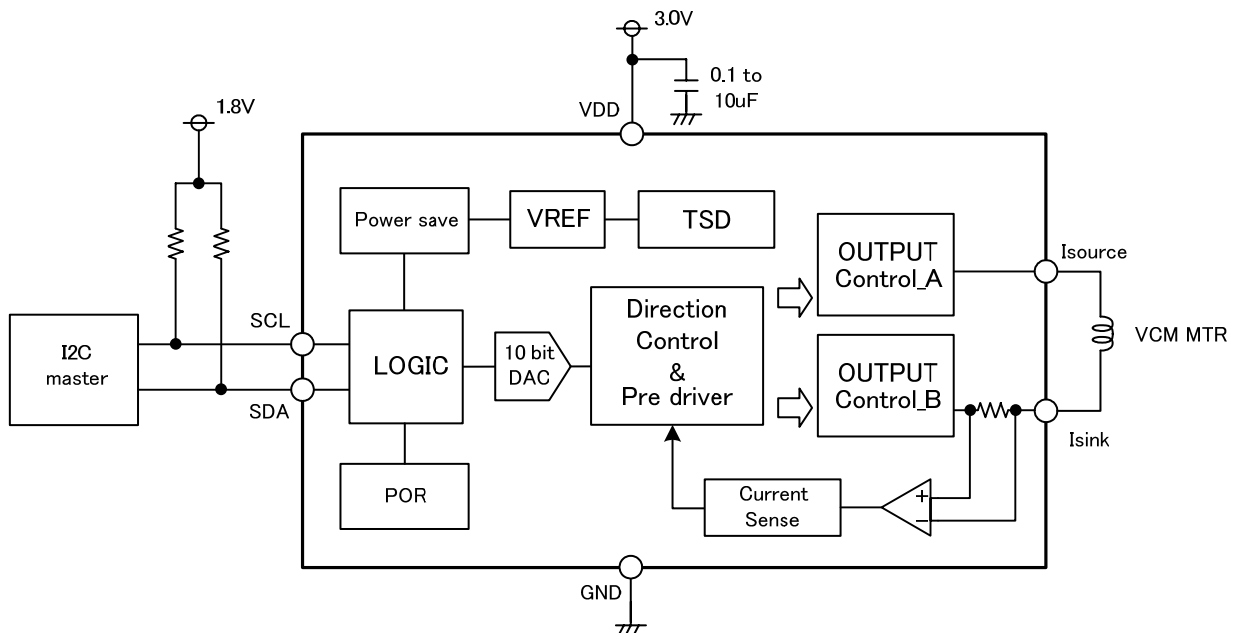

Figure 1. Typical Application Circuit

Pin Configuration

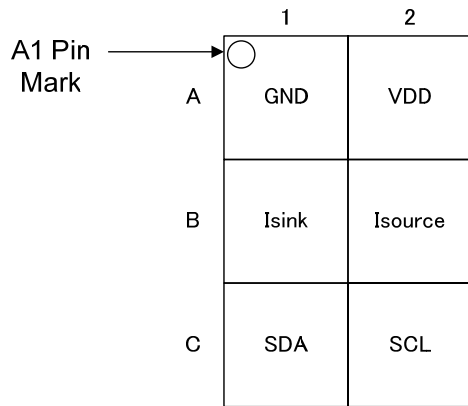

Figure 2. Pin Configuration (Top View)

Pin Descriptions

Pin No.	Symbol	Function
A1	GND	Ground
A2	VDD	Power supply voltage
B1	Isink	Output terminal
B2	Isource	Output terminal
C1	SDA	2-wire serial interface data input
C2	SCL	2-wire serial interface clock input

Block Diagram

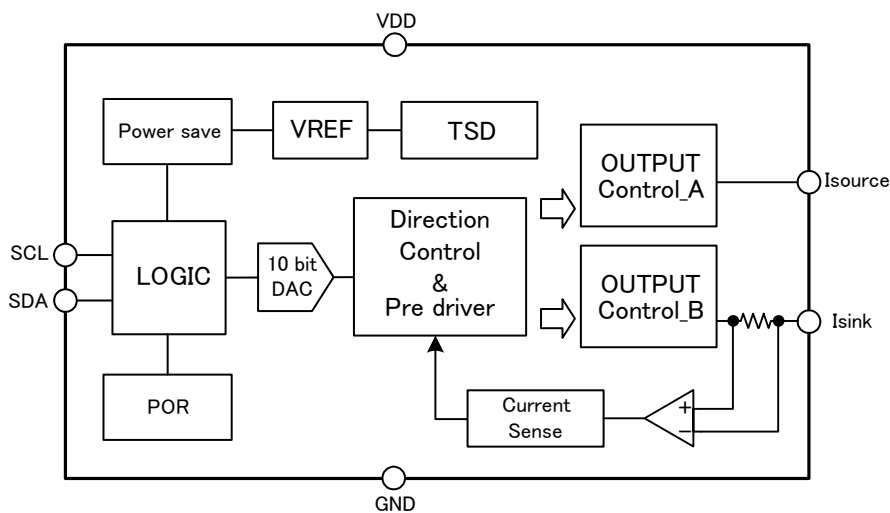

Figure 3. Block Diagram

Absolute Maximum Ratings

Parameter	Symbol	Limits	Unit
Power supply voltage	VDD	-0.5 to +5.5	V
Control input voltage ^(Note1)	VIN	-0.5 to +5.5	V
Power dissipation	Pd	0.32 ^(Note2) , 0.23 ^(Note3)	W
Operating temperature range	Topr	-25 to +85	°C
Junction temperature	Tjmax	125	°C
Storage temperature range	Tstg	-55 to +125	°C
Output current	IOUT	+200, -200 ^(Note4)	mA

(Note 1) VIN is 2-wire serial interface input pins (SCL, SDA).

(Note 2) UCSP30L1 package. Derate by 3.2 mW/°C when operating above Ta=25°C (when mounted in ROHM's standard board).

(Note 3) UCSP16X1 package. Derate by 2.3 mW/°C when operating above Ta=25°C (when mounted in ROHM's standard board).

(Note 4) Must not exceed Pd, ASO, or Tjmax of 125°C.

Caution: Operating the IC over the absolute maximum ratings may damage the IC. The damage can either be a short circuit between pins or an open circuit between pins and the internal circuitry. Therefore, it is important to consider circuit protection measures, such as adding a fuse, in case the IC is operated over the absolute maximum ratings.

Recommended Operating Ratings

Parameter	Symbol	Limits	Unit
Power supply voltage	VDD	+2.3 to +4.8	V
Control input voltage ^(Note1)	VIN	0.0 to +4.8	V
2-wire serial interface frequency	FCLK	400	kHz
Output current	IOUT	+100, -100 ^(Note4)	mA

(Note 1) VIN is 2-wire serial interface input pins (SCL, SDA).

(Note 4) Must not exceed Pd, ASO, or Tjmax of 125°C.

Electrical Characteristics (Unless otherwise specified Ta = 25 °C, VDD = 3.0 V)

Parameter	Symbol	Limit			Unit	Conditions
		Min	Typ	Max		
Power Consumption						
Standby current	ICCST	-	70	120	μA	PS bit = 0
Circuit current	ICC	-	1.0	1.5	mA	EN bit = 0
Control Input (VIN = SCL, SDA)						
High level input voltage	VINH	1.2	-	4.8	V	
Low level input voltage	VINL	0	-	0.5	V	
Low level output voltage	VINOL	-	-	0.4	V	IIN = +3mA (SDA)
High level input current	IINH	-10	-	+10	μA	Input voltage = 0.9 x VIN
Low level input current	IINL	-10	-	+10	μA	Input voltage = 0.1 x VIN
Master Clock						
MCLK frequency	MCLK	-3	-	+3	%	T _{CLK} = 500nsec 2MHz (Typ)
10 Bit D/A Converter (for Controlling Output Current)						
Resolution	DRES	-	10	-	bits	
Differential nonlinearity	DDNL	-1	-	+1	LSB	
Integral nonlinearity	DINL	-4	-	+4	LSB	
Output Current Performance						
Output reference current 1	IOREF1	-3	0	+3	mA	DAC_code=0x200
Output reference current 2	IOREF2	95	100	105	mA	DAC_code=0x3FF
Output reference current 3	IOREF3	-105	-100	-95	mA	DAC_code=0x000
Output resistance	ROUT	-	2.0	3.0	Ω	Ron_P + RNF + Ron_N

2-wire Serial BUS Format (Fast mode SCL = 400 kHz)

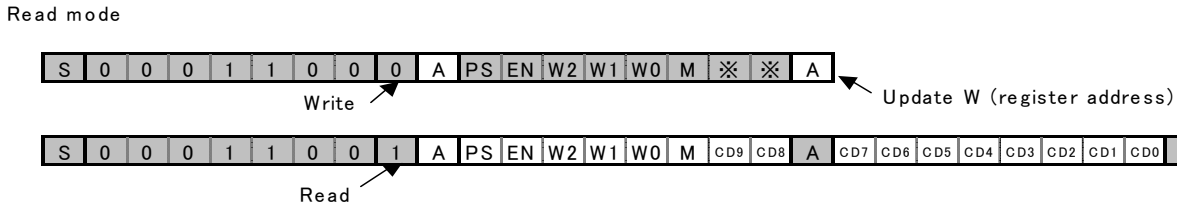
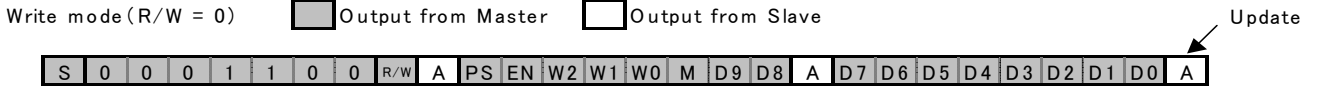

S : start signal P : stop signal
 A : acknowledge nA : non acknowledge ※ : Don't care

Register name	Setting item	Description	Initial value
R/W	Read/write setting	0 = Write to serial registers, 1 = Read from serial registers	0
PS	Serial power save	0 = Driver in standby mode, 1 = Driver in operating mode	0
EN	OUT pin status	0 = Output current set to zero & idling current set to zero, 1 = Constant current drive	0
W2W1W0	Register address	000 = Limit Current	0x0
		001 = ISRC mode or Step mode setting	
		010 = Resonance frequency	
		011 = Step time at Step mode	
		100 = Step width at Step mode	
		110 = Test mode	
M	Mode select signal	0 = Direct mode, 1 = ISRC or Step mode	0
D9 to D0	Limit Current	Target position DAC code [D9:D0]	0x200
	ISRC or Step mode	ISRC Slew rate or Step mode setting [D2:D0] [D2:D0] = 0x00: ISRC mode ((1/f ₀) x 0.5) [D2:D0] = 0x01: ISRC mode ((1/f ₀) x 0.8) [D2:D0] = 0x02: ISRC mode ((1/f ₀) x 1.0) [D2:D0] = 0x03: Step mode	0x00
	Resonance Frequency	Actuator resonance frequency setting [D7:D0], 0.4Hz/LSB(0x01 to 0xFF) [D7:D0] = 0x00: 30Hz [D7:D0] = 0xFF: 132Hz	0x7D
	Step time	Step time [D7:D0], 50us/LSB (0x01 to 0xFF) [D7:D0] = 0x00: 50us [D7:D0] = 0x01: 50us [D7:D0] = 0xFF: 12.75ms	0x00
	Step width	Step resolution [D2:D0] (Step resolution = 1LSB @ 10bit DAC) [D2:D0] = 0x0: 1LSB [D2:D0] = 0x1: 1LSB [D2:D0] = 0x7: 7LSB	0x0

ISRC mode Update Timing (Typ)

Following shows ISRC slew rate parameters.

Register address W[2:0]	ISRC slew_rate D[2:0]	Settling time	Function name
0x1	0x0	$(1/f_0) \times 0.5$	0.5 times control mode
0x1	0x1	$(1/f_0) \times 0.8$	0.8 times control mode
0x1	0x2	$(1/f_0) \times 1.0$	1.0 times control mode

1. Setting 0.5 times control mode

(1) Limit current (W[2:0]=0x0) Update Timing

Settling time is controlled by the resonant frequency of the actuator and the driver's slew rate speed setting. This settling time is decided by the below Equation (1.1). Utilize the slew rate speed parameter in order to modify the settling time so that any updates to the limit current code do not occur before the lens has settled.

$$\text{Equation (1.1)} \quad 0.7 \times T_0$$

where:

f_0 is the VCM resonant frequency.

T_0 is the 1 over f_0 .

$$\text{Example (1.1)} \quad \text{When } f_0 = 100 \text{ Hz, } 0.7 \times 10 \text{ ms} = 7 \text{ ms}$$

(2) Slew_rate Update Timing (Change 0.8 times control mode or 1.0 times control mode)

Slew_rate update timing is also decided by the Equation (1.1).

Take care to not change slew_rate D[2:0] earlier than the timing decided by the Equation (1.1) so that the accidental current may be happened. However, this accidental current doesn't exceed maximum output current.

(3) Step mode Update Timing

When ISRC slew_rate D[2:0] is changed from ISRC mode to step mode, update timing is also decided by the Equation (1.1). While when ISRC slew_rate D[2:0] is changed from step mode to ISRC mode, update timing is after the step action is finished.

2. Setting 0.8 times control mode

(1) Limit current (W[2:0]=0x0) Update Timing

Settling time is controlled by the resonant frequency of the actuator and the driver's slew rate speed setting.

This settling time is decided by the below Equation (2.1). Utilize the slew rate speed parameter in order to modify the settling time so that any updates to the limit current code do not occur before the lens has settled.

$$\text{Equation (2.1)} \quad 1.4 \times T_0$$

$$\text{Example (2.1)} \quad \text{In case } f_0 = 100 \text{ Hz, } 1.4 \times 10 \text{ ms} = 14 \text{ ms}$$

(2) Slew_rate Update Timing (Change 0.5 times control mode or 1.0 times control mode)

Slew_rate update timing is obtained by the Equation (2.2).

For $M = "1"$, take care to not change slew_rate D[2:0] earlier than the timing decided by the Equation (2.2) so that the accidental current may be happened. However, this accidental current doesn't exceed maximum output current.

$$\text{Equation (2.2)} \quad 4.2 \times T_0$$

$$\text{Example (2.2)} \quad \text{In case } f_0 = 100\text{Hz, } 4.2 \times 10 \text{ ms} = 42 \text{ ms}$$

It is necessary to changed from $M = "1"$ to $M = "0"$ when ISRC slew_rate D[2:0] is changed after the time obtained by the Equation (2.1) passes.

Meanwhile, $M = "1"$ and limit current code are input at the same time after ISRC slew_rate D[2:0] is updated.

(3) Step mode Update Timing

When ISRC slew_rate D[2:0] is changed from ISRC mode to step mode, update timing is also decided by the Equation (2.1). While when ISRC slew_rate D[2:0] is changed from step mode to ISRC mode, update timing is after the step action is finished.

3. Setting 1.0 times control mode

Refer to setting 0.8 times control mode in order to the formula for computation is Equation (2.1) and Equation (2.2).

Characteristics of the SDA and SCL Bus Lines for 2-wire Serial Interface
 (Ta = - 25 °C to +85 °C, VDD = 2.3V to 4.8 V)

Parameter	Symbol	STANDARD-MODE ^(Note 5)		FAST-MODE ^(Note 5)		Unit
		Min	Max	Min	Max	
Pulse width of spikes which must be suppressed by the input filter	tSP	0	50	0	50	ns
Hold time (repeated) start condition. The first clock pulse is generated after this period.	tHD;STA	4.0	-	0.6	-	µs
Low period of the SCL clock	tLOW	4.7	-	1.3	-	µs
High period of the SCL clock	tHIGH	4.0	-	0.6	-	µs
Set-up time for repeated START condition	tSU;STA	4.7	-	0.6	-	µs
Data hold time	tHD;DAT	0	3.45	0	0.9	µs
Data set-up time	tSU;DAT	250	-	100	-	ns
Set-up time for stop condition	tSU;STO	4.0	-	0.6	-	µs
Bus free time between a stop and start condition	tBUF	4.7	-	1.3	-	µs

(Note 5) Standard-mode and Fast-mode 2-wire serial interface devices must be able to transmit or receive at that speed.
 The maximum bit transfer rates of 100 kHz for Standard-mode devices and 400 kHz for Fast-mode devices.
 This transfer rates is provided the maximum transfer rates, for example it is able to drive 100 kHz of clocks with Fast-mode.

2-wire Serial Interface Timing

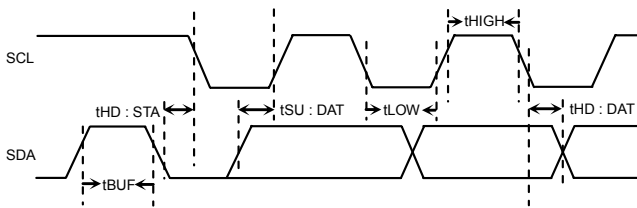

Figure 4. Serial Data Timing

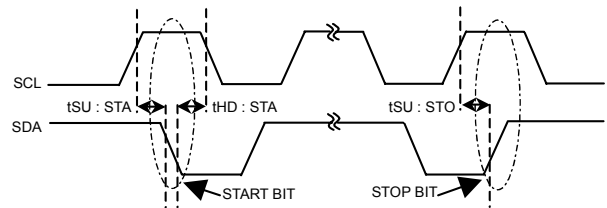

Figure 5. START and STOP Bit Timing

Description of Output Current Characteristics

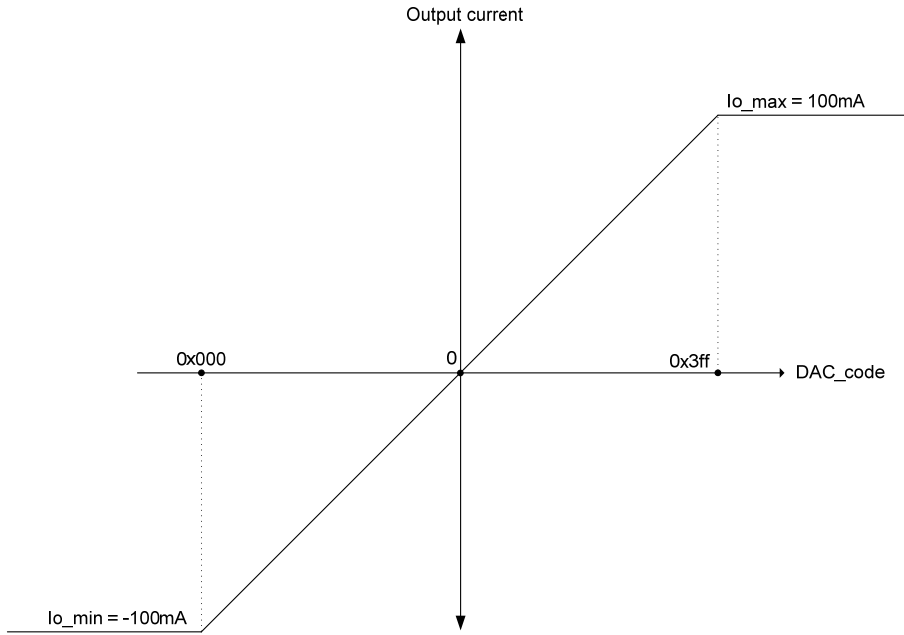
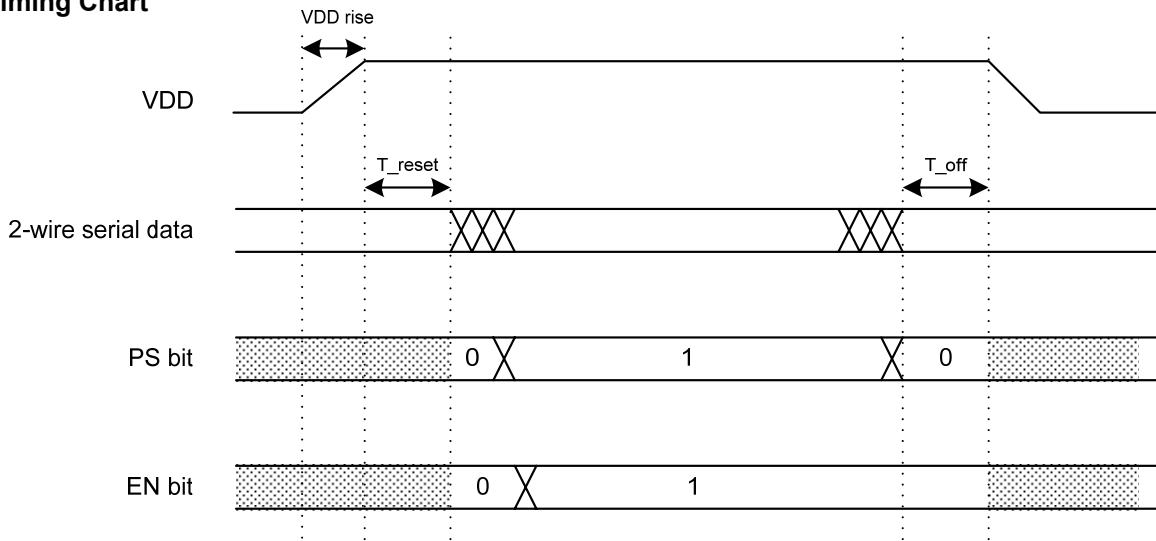

Figure 6. Description of Output Current Characteristics

Timing Chart



Parameter	Symbol	Target			Unit
		Min	Typ	Max	
VDD Rise Time	VDD_rise	0	-	-	μs
Time from VDD rise to first serial command	T_reset	20	-	-	μs
Time delay of last serial command to VDD fall	T_off	1.3	-	-	μs

Power Dissipation

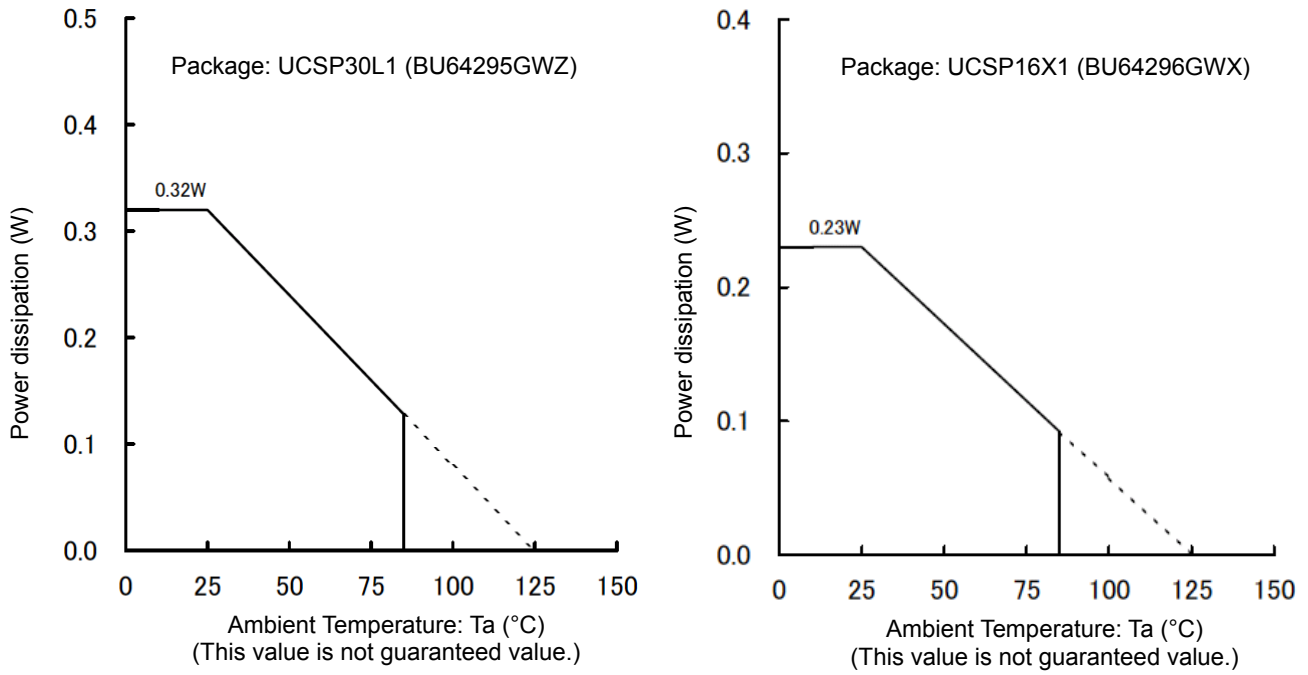
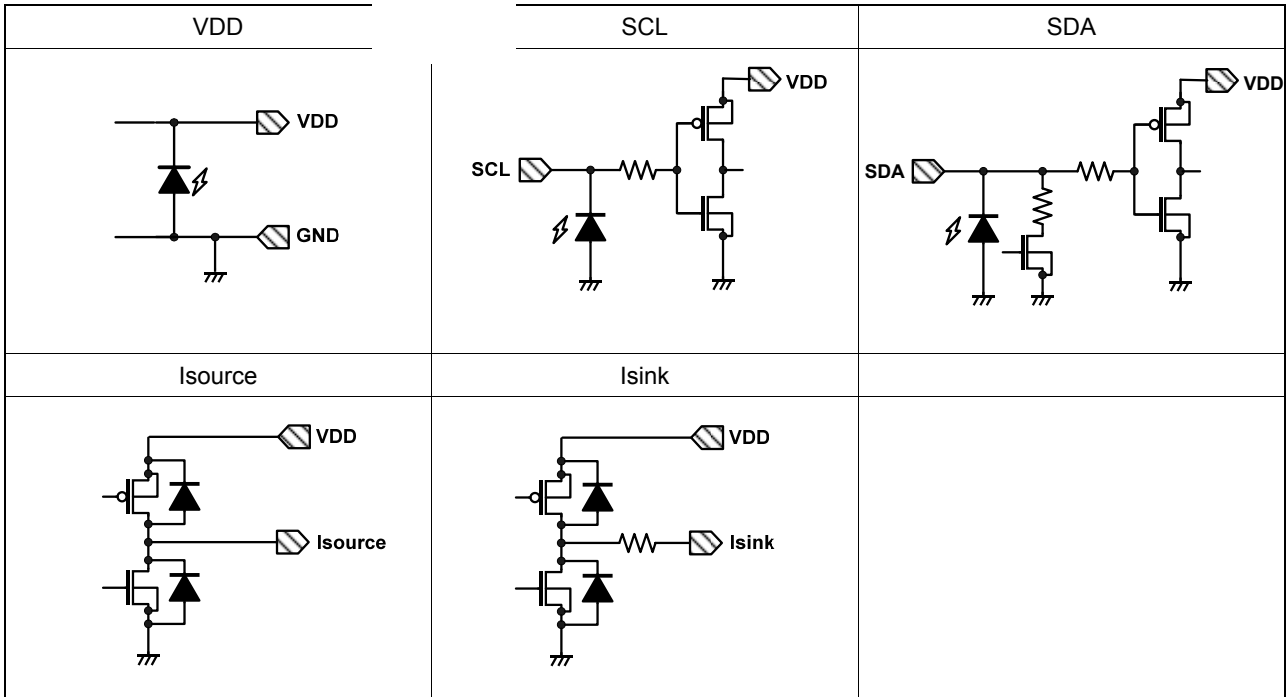

Figure 7. Power dissipation Pd [W]

I/O Equivalence Circuit



Operational Notes

1. Reverse Connection of Power Supply

Connecting the power supply in reverse polarity can damage the IC. Take precautions against reverse polarity when connecting the power supply, such as mounting an external diode between the power supply and the IC's power supply pins.

2. Power Supply Lines

Design the PCB layout pattern to provide low impedance supply lines. Separate the ground and supply lines of the digital and analog blocks to prevent noise in the ground and supply lines of the digital block from affecting the analog block. Furthermore, connect a capacitor to ground at all power supply pins. Consider the effect of temperature and aging on the capacitance value when using electrolytic capacitors.

3. Ground Voltage

Ensure that no pins are at a voltage below that of the ground pin at any time, even during transient condition.

4. Ground Wiring Pattern

When using both small-signal and large-current ground traces, the two ground traces should be routed separately but connected to a single ground at the reference point of the application board to avoid fluctuations in the small-signal ground caused by large currents. Also ensure that the ground traces of external components do not cause variations on the ground voltage. The ground lines must be as short and thick as possible to reduce line impedance.

5. Thermal Consideration

Should by any chance the power dissipation rating be exceeded the rise in temperature of the chip may result in deterioration of the properties of the chip. The absolute maximum rating of the Pd stated in this specification is when the IC is mounted on a 50mm x 58mm x 1.75mm glass epoxy board. In case of exceeding this absolute maximum rating, increase the board size and copper area to prevent exceeding the Pd rating.

6. Recommended Operating Conditions

These conditions represent a range within which the expected characteristics of the IC can be approximately obtained. The electrical characteristics are guaranteed under the conditions of each parameter.

7. Inrush Current

When power is first supplied to the IC, it is possible that the internal logic may be unstable and inrush current may flow instantaneously due to the internal powering sequence and delays, especially if the IC has more than one power supply. Therefore, give special consideration to power coupling capacitance, power wiring, width of ground wiring, and routing of connections.

8. Operation Under Strong Electromagnetic Field

Operating the IC in the presence of a strong electromagnetic field may cause the IC to malfunction.

9. Testing on Application Boards

When testing the IC on an application board, connecting a capacitor directly to a low-impedance output pin may subject the IC to stress. Always discharge capacitors completely after each process or step. The IC's power supply should always be turned off completely before connecting or removing it from the test setup during the inspection process. To prevent damage from static discharge, ground the IC during assembly and use similar precautions during transport and storage.

10. Inter-pin Short and Mounting Errors

Ensure that the direction and position are correct when mounting the IC on the PCB. Incorrect mounting may result in damaging the IC. Avoid nearby pins being shorted to each other especially to ground, power supply and output pin. Inter-pin shorts could be due to many reasons such as metal particles, water droplets (in very humid environment) and unintentional solder bridge deposited in between pins during assembly to name a few.

Operational Notes – continued**11. Unused Input Pins**

Input pins of an IC are often connected to the gate of a MOS transistor. The gate has extremely high impedance and extremely low capacitance. If left unconnected, the electric field from the outside can easily charge it. The small charge acquired in this way is enough to produce a significant effect on the conduction through the transistor and cause unexpected operation of the IC. So unless otherwise specified, unused input pins should be connected to the power supply or ground line.

12. Regarding the Input Pin of the IC

In the construction of this IC, P-N junctions are inevitably formed creating parasitic diodes or transistors. The operation of these parasitic elements can result in mutual interference among circuits, operational faults, or physical damage. Therefore, conditions which cause these parasitic elements to operate, such as applying a voltage to an input pin lower than the ground voltage should be avoided. Furthermore, do not apply a voltage to the input pins when no power supply voltage is applied to the IC. Even if the power supply voltage is applied, make sure that the input pins have voltages within the values specified in the electrical characteristics of this IC.

13. Ceramic Capacitor

When using a ceramic capacitor, determine the dielectric constant considering the change of capacitance with temperature and the decrease in nominal capacitance due to DC bias and others.

14. Area of Safe Operation (ASO)

Operate the IC such that the output voltage, output current, and power dissipation are all within the Area of Safe Operation (ASO).

15. Thermal Shutdown Circuit(TSD)

This IC has a built-in thermal shutdown circuit that prevents heat damage to the IC. Normal operation should always be within the IC's power dissipation rating. If however the rating is exceeded for a continued period, the junction temperature (T_j) will rise which will activate the TSD circuit that will turn OFF all output pins. When the T_j falls below the TSD threshold, the circuits are automatically restored to normal operation.

Note that the TSD circuit operates in a situation that exceeds the absolute maximum ratings and therefore, under no circumstances, should the TSD circuit be used in a set design or for any purpose other than protecting the IC from heat damage.

Ordering Information BU64295GWZ

B U 6 4 2 9 5 G W Z

TR

Part Number

Package
GWZ: UCSP30L1

Packaging and forming specification
TR: Embossed carrier tape

Marking Diagram BU64295GWZ (TOP VIEW)

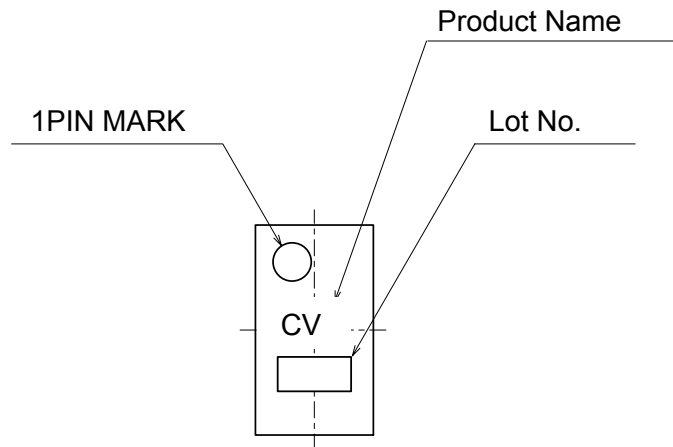

Ordering Information BU64296GWX

B U 6 4 2 9 6 G W X

TR

Part Number

Package
GWZ: UCSP16X1

Packaging and forming specification
TR: Embossed carrier tape

Marking Diagram BU64296GWX (TOP VIEW)

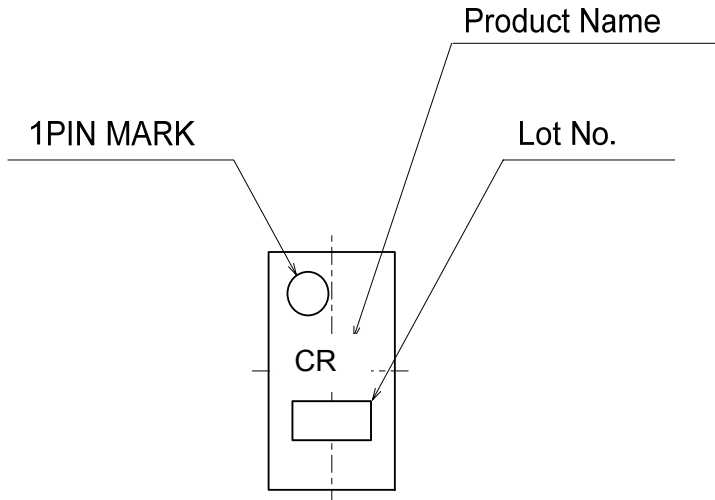

Physical Dimension Tape and Reel Information

Package Name	UCSP30L1(BU64295GWZ)
--------------	----------------------

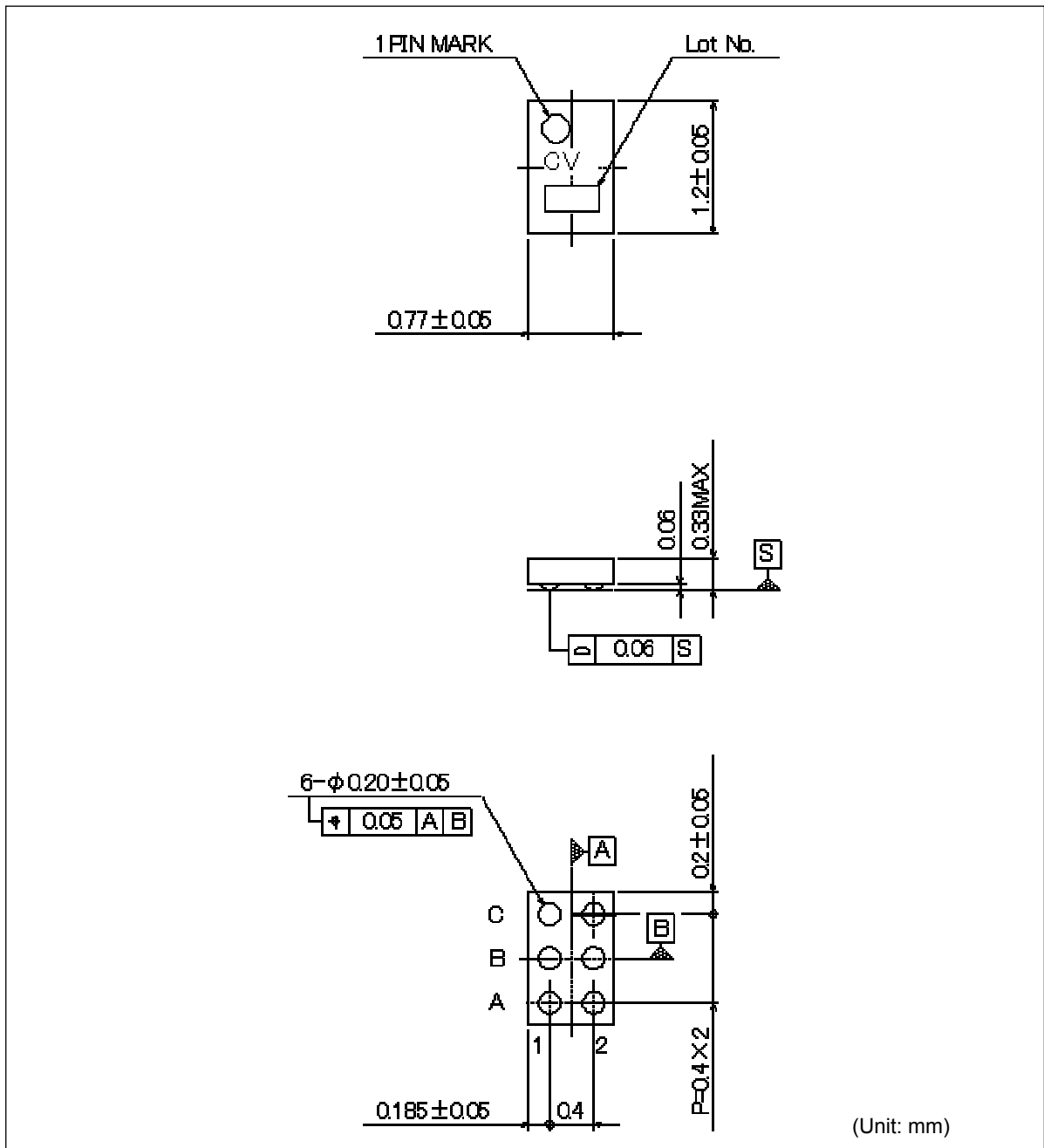

(Unit: mm)

< Tape and Reel Information >

Tape	Embossed carrier tape
Quantity	6,000pcs
Direction of feed	TR The direction is the pin 1 of product is at the upper right when you hold reel on the left hand and you pull out the tape on the right hand.

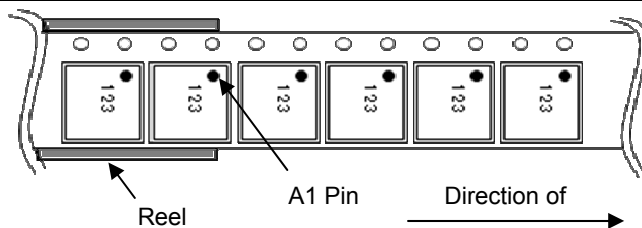

*Order quantity needs to be multiple of the minimum quantity.

Physical Dimension Tape and Reel Information

Package Name	UCSP16X1(BU64296GWX)
--------------	----------------------

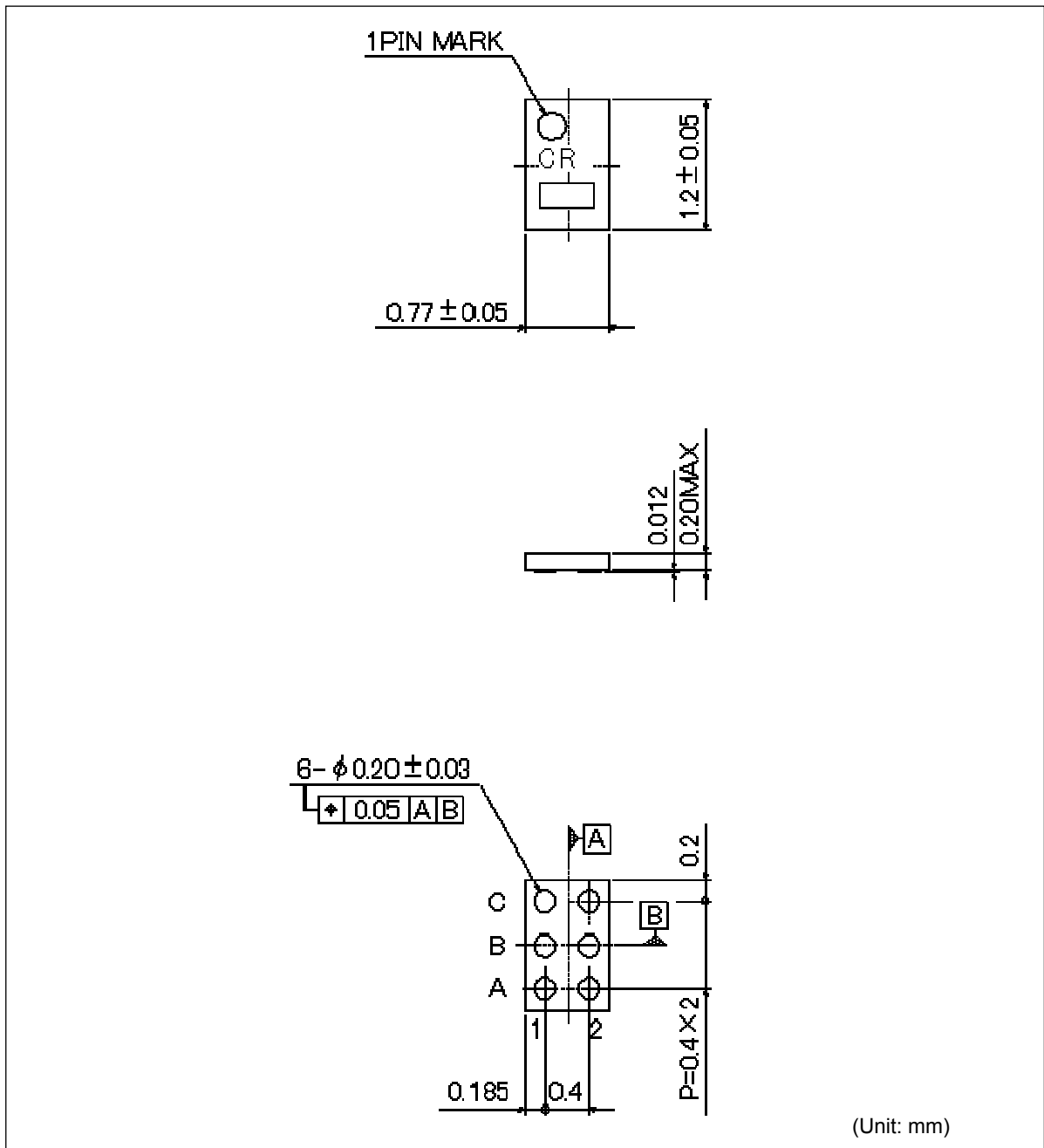

(Unit: mm)

< Tape and Reel Information >

Tape	Embossed carrier tape
Quantity	6,000pcs
Direction of feed	TR The direction is the pin 1 of product is at the upper right when you hold reel on the left hand and you pull out the tape on the right hand.

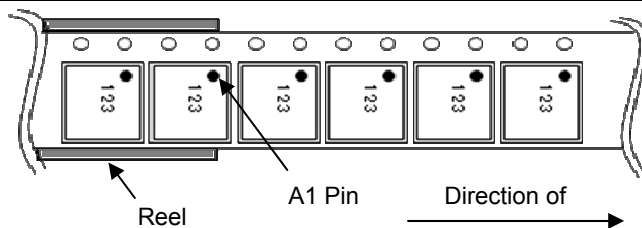

*Order quantity needs to be multiple of the minimum quantity.

Revision History

Date	Revision	Changes
15. Apr. 2014	001	New Release
26. Jun. 2014	002	Change quantity of BU64297GWZ from 3000 to 6000 at page 16.
13. Nov.2014	003	Delete BU64297GWZ

Notice

Precaution on using ROHM Products

- Our Products are designed and manufactured for application in ordinary electronic equipments (such as AV equipment, OA equipment, telecommunication equipment, home electronic appliances, amusement equipment, etc.). If you intend to use our Products in devices requiring extremely high reliability (such as medical equipment ^(Note 1), transport equipment, traffic equipment, aircraft/spacecraft, nuclear power controllers, fuel controllers, car equipment including car accessories, safety devices, etc.) and whose malfunction or failure may cause loss of human life, bodily injury or serious damage to property ("Specific Applications"), please consult with the ROHM sales representative in advance. Unless otherwise agreed in writing by ROHM in advance, ROHM shall not be in any way responsible or liable for any damages, expenses or losses incurred by you or third parties arising from the use of any ROHM's Products for Specific Applications.

(Note1) Medical Equipment Classification of the Specific Applications

JAPAN	USA	EU	CHINA
CLASS III	CLASS III	CLASS II b	CLASS III
CLASS IV		CLASS III	

- ROHM designs and manufactures its Products subject to strict quality control system. However, semiconductor products can fail or malfunction at a certain rate. Please be sure to implement, at your own responsibilities, adequate safety measures including but not limited to fail-safe design against the physical injury, damage to any property, which a failure or malfunction of our Products may cause. The following are examples of safety measures:
 - Installation of protection circuits or other protective devices to improve system safety
 - Installation of redundant circuits to reduce the impact of single or multiple circuit failure
- Our Products are designed and manufactured for use under standard conditions and not under any special or extraordinary environments or conditions, as exemplified below. Accordingly, ROHM shall not be in any way responsible or liable for any damages, expenses or losses arising from the use of any ROHM's Products under any special or extraordinary environments or conditions. If you intend to use our Products under any special or extraordinary environments or conditions (as exemplified below), your independent verification and confirmation of product performance, reliability, etc. prior to use, must be necessary:
 - Use of our Products in any types of liquid, including water, oils, chemicals, and organic solvents
 - Use of our Products outdoors or in places where the Products are exposed to direct sunlight or dust
 - Use of our Products in places where the Products are exposed to sea wind or corrosive gases, including Cl₂, H₂S, NH₃, SO₂, and NO₂
 - Use of our Products in places where the Products are exposed to static electricity or electromagnetic waves
 - Use of our Products in proximity to heat-producing components, plastic cords, or other flammable items
 - Sealing or coating our Products with resin or other coating materials
 - Use of our Products without cleaning residue of flux (even if you use no-clean type fluxes, cleaning residue of flux is recommended); or Washing our Products by using water or water-soluble cleaning agents for cleaning residue after soldering
 - Use of the Products in places subject to dew condensation
- The Products are not subject to radiation-proof design.
- Please verify and confirm characteristics of the final or mounted products in using the Products.
- In particular, if a transient load (a large amount of load applied in a short period of time, such as pulse. is applied, confirmation of performance characteristics after on-board mounting is strongly recommended. Avoid applying power exceeding normal rated power; exceeding the power rating under steady-state loading condition may negatively affect product performance and reliability.
- De-rate Power Dissipation depending on ambient temperature. When used in sealed area, confirm that it is the use in the range that does not exceed the maximum junction temperature.
- Confirm that operation temperature is within the specified range described in the product specification.
- ROHM shall not be in any way responsible or liable for failure induced under deviant condition from what is defined in this document.

Precaution for Mounting / Circuit board design

- When a highly active halogenous (chlorine, bromine, etc.) flux is used, the residue of flux may negatively affect product performance and reliability.
- In principle, the reflow soldering method must be used on a surface-mount products, the flow soldering method must be used on a through hole mount products. If the flow soldering method is preferred on a surface-mount products, please consult with the ROHM representative in advance.

For details, please refer to ROHM Mounting specification

Precautions Regarding Application Examples and External Circuits

1. If change is made to the constant of an external circuit, please allow a sufficient margin considering variations of the characteristics of the Products and external components, including transient characteristics, as well as static characteristics.
2. You agree that application notes, reference designs, and associated data and information contained in this document are presented only as guidance for Products use. Therefore, in case you use such information, you are solely responsible for it and you must exercise your own independent verification and judgment in the use of such information contained in this document. ROHM shall not be in any way responsible or liable for any damages, expenses or losses incurred by you or third parties arising from the use of such information.

Precaution for Electrostatic

This Product is electrostatic sensitive product, which may be damaged due to electrostatic discharge. Please take proper caution in your manufacturing process and storage so that voltage exceeding the Products maximum rating will not be applied to Products. Please take special care under dry condition (e.g. Grounding of human body / equipment / solder iron, isolation from charged objects, setting of Ionizer, friction prevention and temperature / humidity control).

Precaution for Storage / Transportation

1. Product performance and soldered connections may deteriorate if the Products are stored in the places where:
 - [a] the Products are exposed to sea winds or corrosive gases, including Cl₂, H₂S, NH₃, SO₂, and NO₂
 - [b] the temperature or humidity exceeds those recommended by ROHM
 - [c] the Products are exposed to direct sunshine or condensation
 - [d] the Products are exposed to high Electrostatic
2. Even under ROHM recommended storage condition, solderability of products out of recommended storage time period may be degraded. It is strongly recommended to confirm solderability before using Products of which storage time is exceeding the recommended storage time period.
3. Store / transport cartons in the correct direction, which is indicated on a carton with a symbol. Otherwise bent leads may occur due to excessive stress applied when dropping of a carton.
4. Use Products within the specified time after opening a humidity barrier bag. Baking is required before using Products of which storage time is exceeding the recommended storage time period.

Precaution for Product Label

A two-dimensional barcode printed on ROHM Products label is for ROHM's internal use only.

Precaution for Disposition

When disposing Products please dispose them properly using an authorized industry waste company.

Precaution for Foreign Exchange and Foreign Trade act

Since concerned goods might be fallen under listed items of export control prescribed by Foreign exchange and Foreign trade act, please consult with ROHM in case of export.

Precaution Regarding Intellectual Property Rights

1. All information and data including but not limited to application example contained in this document is for reference only. ROHM does not warrant that foregoing information or data will not infringe any intellectual property rights or any other rights of any third party regarding such information or data.
2. ROHM shall not have any obligations where the claims, actions or demands arising from the combination of the Products with other articles such as components, circuits, systems or external equipment (including software).
3. No license, expressly or implied, is granted hereby under any intellectual property rights or other rights of ROHM or any third parties with respect to the Products or the information contained in this document. Provided, however, that ROHM will not assert its intellectual property rights or other rights against you or your customers to the extent necessary to manufacture or sell products containing the Products, subject to the terms and conditions herein.

Other Precaution

1. This document may not be reprinted or reproduced, in whole or in part, without prior written consent of ROHM.
2. The Products may not be disassembled, converted, modified, reproduced or otherwise changed without prior written consent of ROHM.
3. In no event shall you use in any way whatsoever the Products and the related technical information contained in the Products or this document for any military purposes, including but not limited to, the development of mass-destruction weapons.
4. The proper names of companies or products described in this document are trademarks or registered trademarks of ROHM, its affiliated companies or third parties.

General Precaution

1. Before you use our Products, you are requested to carefully read this document and fully understand its contents. ROHM shall not be in any way responsible or liable for failure, malfunction or accident arising from the use of any ROHM's Products against warning, caution or note contained in this document.
2. All information contained in this document is current as of the issuing date and subject to change without any prior notice. Before purchasing or using ROHM's Products, please confirm the latest information with a ROHM sales representative.
3. The information contained in this document is provided on an "as is" basis and ROHM does not warrant that all information contained in this document is accurate and/or error-free. ROHM shall not be in any way responsible or liable for any damages, expenses or losses incurred by you or third parties resulting from inaccuracy or errors of or concerning such information.

X-ON Electronics

Largest Supplier of Electrical and Electronic Components

Click to view similar products for [Motor/Motion/Ignition Controllers & Drivers](#) category:

Click to view products by [ROHM](#) manufacturer:

Other Similar products are found below :

[FSB50550TB2](#) [FSBF15CH60BTH](#) [MSVCPM2-63-12](#) [MSVGW45-14-2](#) [MSVGW54-14-3](#) [MSVGW54-14-5](#) [NTE7043](#) [LA6565VR-TLM-E](#)
[LB11650-E](#) [LB1837M-TLM-E](#) [LB1845DAZ-XE](#) [LC898300XA-MH](#) [SS30-TE-L-E](#) [26700](#) [LV8281VR-TLM-H](#) [BA5839FP-E2](#) [IRAM236-1067A](#) [LA6584JA-AH](#) [LB11847L-E](#) [NCV70501DW002R2G](#) [AH293-PL-B](#) [TND315S-TL-2H](#) [FNA23060](#) [FSB50250AB](#) [FNA41060](#)
[MSVB54](#) [MSVBTC50E](#) [MSVCPM3-54-12](#) [MSVCPM3-63-12](#) [MSVCPM4-63-12](#) [MSVTA120](#) [FSB50550AB](#) [NCV70501DW002G](#)
[LC898301XA-MH](#) [LV8413GP-TE-L-E](#) [MSVGW45-14-3](#) [MSVGW45-14-4](#) [MSVGW45-14-5](#) [MSVGW54-14-4](#) [STK984-091A-E](#)
[SLA7026M](#) [MP6519GQ-Z](#) [LB11651-E](#) [IRSM515-025DA4](#) [LV8127T-TLM-H](#) [MC33812EKR2](#) [NCP81382MNTXG](#) [TDA21801](#)
[LB11851FA-BH](#) [NCV70627DQ001R2G](#)