



## ± 2g / 4g / 8g Tri-axis Digital Accelerometer Specifications

PART NUMBER:

KX126-1063

Rev. 1.0

22-Jun-17

### Product Description

The KX126-1063 is a tri-axis  $\pm 2g$ ,  $\pm 4g$  or  $\pm 8g$  silicon micromachined accelerometer with integrated Pedometer, 2048-byte buffer, orientation, tap/double tap, activity detecting, and Free fall algorithms. The sense element is fabricated using Kionix's proprietary plasma micromachining process technology. Acceleration sensing is based on the principle of a differential capacitance arising from acceleration-induced motion of the sense element, which further utilizes common mode cancellation to decrease errors from process variation, temperature, and environmental stress. The sense element is hermetically sealed at the wafer level by bonding a second silicon lid wafer to the device using a glass frit. A separate ASIC device packaged with the sense element provides signal conditioning, and intelligent user-programmable application algorithms. The accelerometer is delivered in a 2 x 2 x 0.9 mm LGA plastic package

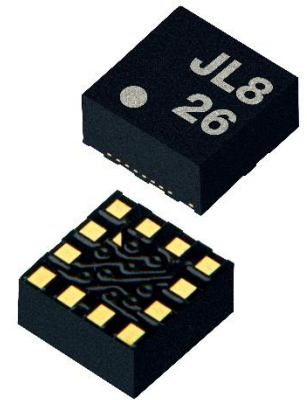

operating from a 1.71V – 3.6V DC supply. Voltage regulators are used to maintain constant internal operating voltages over the range of input supply voltages. This results in stable operating characteristics over the range of input supply voltages. I<sup>2</sup>C or SPI digital protocol is used to communicate with the chip to configure and check for updates to the orientation, Directional Tap™ detection, Free fall detection, Pedometer and activity monitoring algorithms.

### Features

- Small footprint: 2 x 2 x 0.9 mm LGA 12-pin package (pin-to-pin compatible with KX122)
- User-configurable g-range up to  $\pm 8g$  and Output Data Rate up to 25600Hz
- Integrated pedometer (step counter) with overflow, watermark, and increment interrupts
- High resolution Wake-Up/Back-to-Sleep functions with threshold configurable down to 3.9 mg
- User accessible manufacturer and part ID registers
- Integrated Free fall, Directional Tap/Double-Tap™, and Device-orientation Algorithms
- Improved ODR accuracy in low power mode over temperature
- Factory Programmed Offset and Sensitivity with improved performance over temperature
- Extra-large embedded 2048 byte FIFO/FILO buffer continues to record data even when being read
- Low Power Consumption with FlexSet™ Performance Optimization
- User-selectable Low Power or High Resolution modes
- Internal voltage regulator
- Digital I<sup>2</sup>C up to 3.4MHz and Digital SPI up to 10MHz
- RoHS / REACH compliant
- Excellent temperature performance with high shock survivability
- Self-test Function
- Digital High-Pass Filter Outputs



# ± 2g / 4g / 8g Tri-axis Digital Accelerometer Specifications

**PART NUMBER:**  
**KX126-1063**  
**Rev. 1.0**  
**22-Jun-17**

## Table of Contents

<b>PRODUCT DESCRIPTION</b> .....	<b>1</b>
<b>FEATURES</b> .....	<b>1</b>
<b>TABLE OF CONTENTS</b> .....	<b>2</b>
<b>FUNCTIONAL DIAGRAM</b> .....	<b>5</b>
<b>PRODUCT SPECIFICATIONS</b> .....	<b>6</b>
MECHANICAL .....	6
ELECTRICAL .....	7
<i>Start Up Time Profile</i> .....	8
<i>Current Profile</i> .....	8
<i>Power-On Procedure</i> .....	9
ENVIRONMENTAL .....	10
TERMINOLOGY .....	11
FUNCTIONALITY .....	12
APPLICATION SCHEMATIC .....	13
PIN DESCRIPTIONS .....	13
PACKAGE DIMENSIONS AND ORIENTATION .....	14
<i>Dimensions</i> .....	14
<i>Orientation</i> .....	15
<b>DIGITAL INTERFACE</b> .....	<b>17</b>
I <sup>2</sup> C SERIAL INTERFACE .....	17
<i>I<sup>2</sup>C Operation</i> .....	18
<i>Writing to an 8-bit Register</i> .....	20
<i>Reading from an 8-bit Register</i> .....	20
<i>Data Transfer Sequences</i> .....	21
<i>HS-mode</i> .....	22
<i>I<sup>2</sup>C Timing Diagram</i> .....	23
SPI COMMUNICATIONS .....	24
<i>4-Wire SPI Interface</i> .....	24
<i>4-Wire SPI Timing Diagram</i> .....	25
<i>4-Wire Read and Write Registers</i> .....	26
<i>3-Wire SPI Interface</i> .....	27
<i>3-Wire SPI Timing Diagram</i> .....	28
<i>3-Wire Read and Write Registers</i> .....	29
<b>EMBEDDED REGISTERS</b> .....	<b>30</b>
ACCELEROMETER OUTPUTS .....	31
MAN_ID .....	32
PART_ID .....	32
XHP_L .....	32
XHP_H .....	32
YHP_L .....	33



# ± 2g / 4g / 8g Tri-axis Digital Accelerometer Specifications

**PART NUMBER:**

**KX126-1063**

**Rev. 1.0**

**22-Jun-17**

YHP_H .....	33
ZHP_L .....	33
ZHP_H .....	33
XOUT_L .....	34
XOUT_H.....	34
YOUT_L .....	34
YOUT_H.....	34
ZOUT_L.....	35
ZOUT_H.....	35
PED_STP_L AND PED_STP_H .....	35
COTR .....	35
WHO_AM_I.....	36
TSCP .....	36
TSPP .....	36
INS1.....	37
INS2.....	37
INS3.....	38
STAT .....	39
INT_REL.....	40
CNTL1.....	40
CNTL2.....	41
CNTL3.....	42
CNTL4.....	43
CNTL5.....	45
ODCNTL.....	46
INC1 .....	48
INC2 .....	49
INC3 .....	49
INC4 .....	50
INC5 .....	51
INC6 .....	52
INC7 .....	53
TILT_TIMER .....	54
TDTRC.....	54
TDTC.....	55
TTH.....	55
TTL.....	56
FTD .....	56
STD .....	57
TLT.....	57
TWS.....	58
FFTH .....	58
FFC .....	58
FFCNTL .....	58



# ± 2g / 4g / 8g Tri-axis Digital Accelerometer Specifications

**PART NUMBER:**  
**KX126-1063**  
**Rev. 1.0**  
**22-Jun-17**

TILT\_ANGLE\_LL ..... 59

TILT\_ANGLE\_HL..... 60

HYST\_SET ..... 60

LP\_CNTL ..... 61

WUFTH, BTSWUFTH AND BTSTH ..... 62

BTSC ..... 62

WUFC ..... 63

PED\_STPWM\_L AND PED\_STPWM\_H ..... 63

PED\_CNTL1 ..... 63

PED\_CNTL2 ..... 64

PED\_CNTL3 ..... 65

PED\_CNTL4 ..... 65

PED\_CNTL5 ..... 66

PED\_CNTL6 ..... 66

PED\_CNTL7 ..... 66

PED\_CNTL8 ..... 67

PED\_CNTL9 ..... 67

PED\_CNTL10 ..... 67

SELF\_TEST ..... 68

BUF\_CNTL1 ..... 68

BUF\_CNTL2 ..... 69

BUF\_STATUS\_1 AND BUF\_STATUS\_2 ..... 70

BUF\_CLEAR ..... 71

BUF\_READ ..... 71

**EMBEDDED APPLICATIONS ..... 72**

    ORIENTATION DETECTION FEATURE ..... 72

*Hysteresis*..... 72

*Device Orientation Angle (aka Tilt Angle)*..... 73

    MOTION INTERRUPT FEATURE DESCRIPTION ..... 75

    DIRECTIONAL TAP DETECTION FEATURE DESCRIPTION ..... 78

*Performance Index*..... 78

*Single Tap Detection*..... 79

*Double Tap Detection* ..... 80

    FREE FALL DETECT..... 81

    SAMPLE BUFFER FEATURE DESCRIPTION ..... 83

*FIFO Mode* ..... 83

*Stream Mode* ..... 83

*Trigger Mode* ..... 84

*FILO Mode* ..... 84

*Buffer Operation*..... 84

    PEDOMETER (STEP COUNTER) FEATURE ..... 90

**REVISION HISTORY ..... 91**

**APPENDIX ..... 92**



# ± 2g / 4g / 8g Tri-axis Digital Accelerometer Specifications

PART NUMBER:

KX126-1063

Rev. 1.0

22-Jun-17

## Functional Diagram

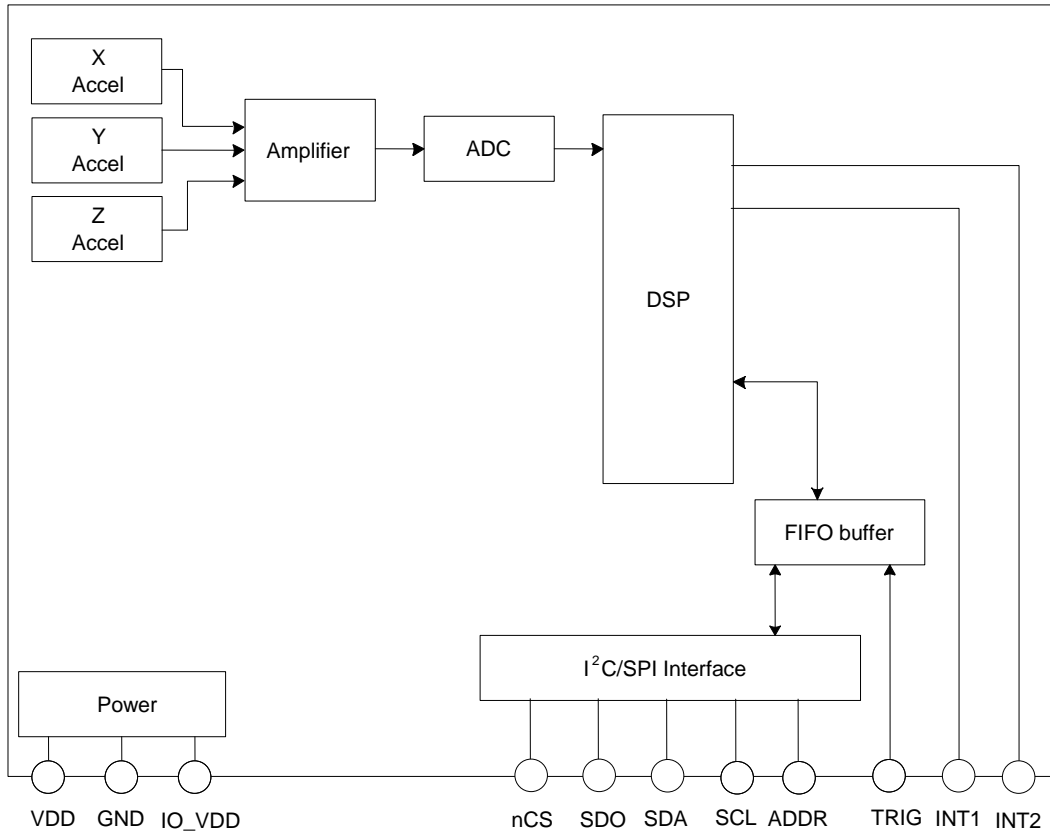

	<b>± 2g / 4g / 8g Tri-axis Digital Accelerometer Specifications</b>	<b>PART NUMBER:</b> <b>KX126-1063</b> <b>Rev. 1.0</b> <b>22-Jun-17</b>
---	---	---

## Product Specifications

### Mechanical

(specifications are for operation at 2.5V and T = 25°C unless stated otherwise)

Parameters		Units	Min	Typical	Max
Operating Temperature Range		°C	-40	-	85
Zero-g Offset		mg		±25	±90
Zero-g Offset Variation from RT over Temp.		± mg/°C		0.2	
Sensitivity <sup>1</sup> (16 bit)	GSEL1=0, GSEL0=0 (± 2g)	counts/g	15401	16384	17367
	GSEL1=0, GSEL0=1 (± 4g)		7700	8192	8684
	GSEL1=1, GSEL0=0 (± 8g)		3850	4096	4342
Sensitivity (Buffer 8-bit mode) <sup>1,2</sup>	GSEL1=0, GSEL0=0 (± 2g)	counts/g	60	64	68
	GSEL1=0, GSEL0=1 (± 4g)		30	32	34
	GSEL1=1, GSEL0=0 (± 8g)		15	16	17
Sensitivity Variation from RT over Temp.		%/°C		0.01	
Positive Self Test Output change on Activation <sup>5</sup>		g		0.5	
Mechanical Resonance (-3dB) <sup>3</sup>		Hz		3500 (xy) 1800 (z)	
Non-Linearity		% of FS		0.6	
Cross Axis Sensitivity		± %		2	
Noise <sup>4,6</sup>	RMS	mg		0.70	
	Density	µg/√Hz		130	

**Table 1: Mechanical Specifications**

#### Notes:

- Resolution and acceleration ranges are user selectable via I<sup>2</sup>C or SPI.
- Sensitivity is proportional to BRES in BUF\_CNTL2.
- Resonance as defined by the dampened mechanical sensor.
- Noise varies with Output Data Rate (ODR), and the Average Filter Control settings and can be tested using Kionix FlexSet™ Performance Optimization Tool found at <http://www.kionix.com/flexset>.
- Requires changing of STPOL bit in INC1 register to 1 prior to performing self-test
- Measured with ODR = 50Hz, LPRO = 1 (filter corner frequency set to ODR/2)



# ± 2g / 4g / 8g Tri-axis Digital Accelerometer Specifications

**PART NUMBER:**  
**KX126-1063**  
**Rev. 1.0**  
**22-Jun-17**

## Electrical

(specifications are for operation at 2.5V and T = 25°C unless stated otherwise)

Parameters		Units	Min	Typical	Max
Supply Voltage (VDD)	Operating	V	1.71	2.5	3.6
I/O Pads Supply Voltage (IO_VDD)		V	1.7		VDD
Current Consumption	High Resolution Mode (RES = 1)	μA		145	
	Low Power Mode <sup>1</sup> (RES = 0)			10	
	Standby			0.9	
Output Low Voltage (IO_VDD < 2V) <sup>2</sup>		V	-	-	0.2 * IO_VDD
Output Low Voltage (IO_VDD ≥ 2V) <sup>2</sup>		V	-	-	0.4
Output High Voltage		V	0.8 * IO_VDD	-	-
Input Low Voltage		V	-	-	0.2 * IO_VDD
Input High Voltage		V	0.8 * IO_VDD	-	-
Start Up Time <sup>3</sup>		ms	2.0		1300
Power Up Time <sup>4</sup>		ms		20	50
I <sup>2</sup> C Communication Rate		MHz			3.4
SPI Communication Rate		MHz			10
Output Data Rate (ODR) <sup>5</sup>		Hz	0.781	50	25600
Bandwidth (-3dB) <sup>6</sup>	RES = 0	Hz		800	
	RES = 1	Hz		ODR/2	

**Table 2: Electrical Specifications**

**Notes:**

1. Current varies with Output Data Rate (ODR) as shown in Figure 1, types and number of enabled digital engines, and the Average Filter Control settings that can be tested using Kionix FlexSet™ Performance Optimization Tool found at <http://www.kionix.com/flexset>.
2. For I<sup>2</sup>C communication, this assumes a minimum 1.5kΩ pull-up resistor on SCL and SDA pins.
3. Start up time is from PC1 set to valid outputs. Time varies with Output Data Rate (ODR); see chart below
4. Power up time is from VDD valid to device boot completion.
5. User selectable through I<sup>2</sup>C or SPI.
6. User selectable and dependent on ODR and RES.



# ± 2g / 4g / 8g Tri-axis Digital Accelerometer Specifications

**PART NUMBER:**

**KX126-1063**

**Rev. 1.0**

**22-Jun-17**

## Start Up Time Profile

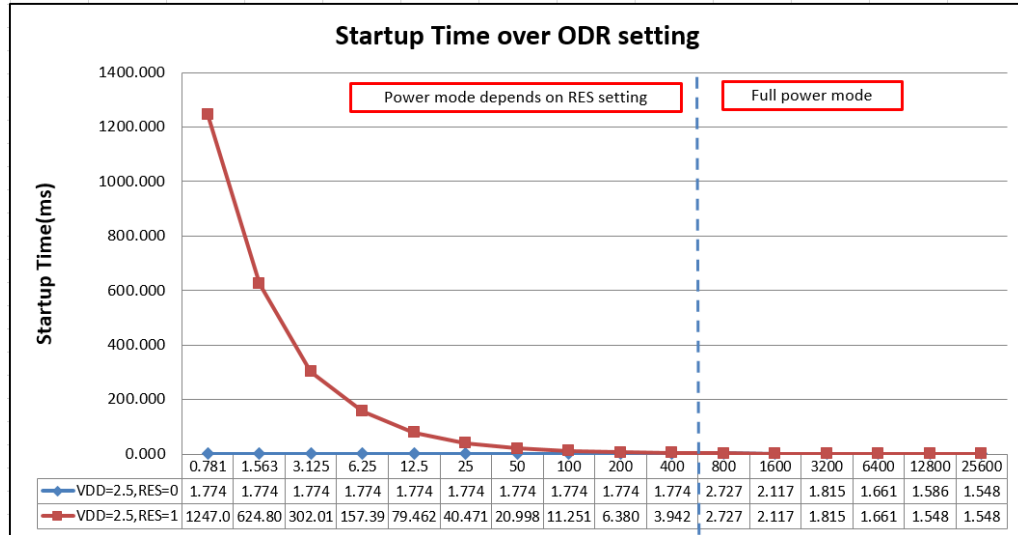

## Current Profile

Representative Current Profile (µA)		
ODR (Hz)	High Res	Low Current
0	145	0.9
0.781	145	1.8
1.563	145	2.0
3.125	145	2.2
6.25	145	3.0
12.5	145	5
25	145	7
50	145	13
100	145	21
200	145	43
400	145	145
800	145	145
1600	145	145
3200	145	145
6400	145	145
12800	145	145
25600	145	145

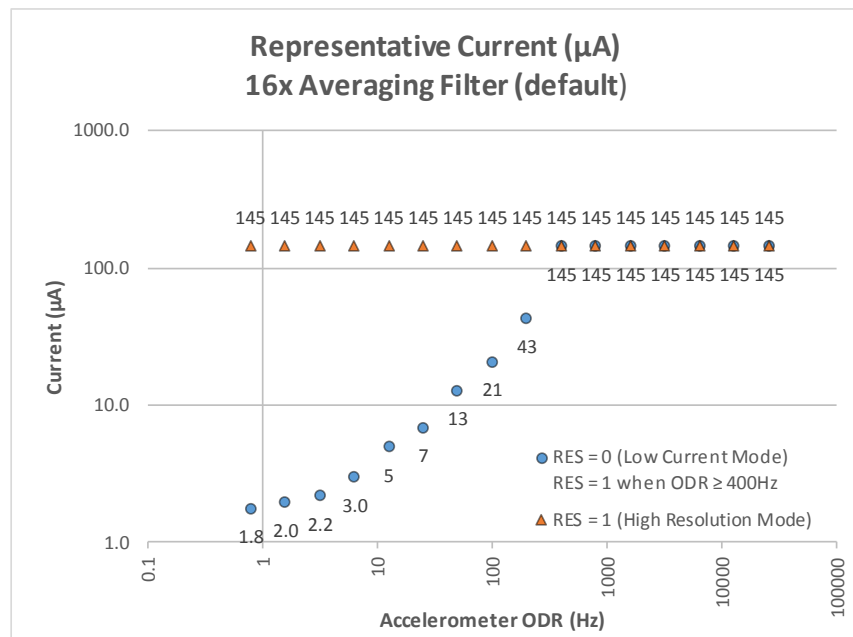

**Figure 1:** Current as a function of Output Data Rate (ODR) and Power Mode Settings



	<b>± 2g / 4g / 8g Tri-axis Digital Accelerometer Specifications</b>	<b>PART NUMBER:</b> <b>KX126-1063</b> <b>Rev. 1.0</b> <b>22-Jun-17</b>
---	---	---

### Power-On Procedure

Proper functioning of power-on reset (POR) is dependent on the specific **VDD**, **VDD<sub>Low</sub>**, **T<sub>VDD</sub>** (rise time), and **T<sub>VDD\_OFF</sub>** profile of individual applications. It is recommended to minimize **VDD<sub>Low</sub>**, and **T<sub>VDD</sub>**, and maximize **T<sub>VDD\_OFF</sub>**. It is also advised that the **VDD** ramp up time **T<sub>VDD</sub>** be monotonic. Note that the outputs will not be stable until **VDD** has reached its final value.

- ! *To assure proper POR, the application should be evaluated over the customer specified range of VDD, VDD<sub>Low</sub>, T<sub>VDD</sub>, T<sub>VDD\_OFF</sub> and temperature as POR performance can vary depending on these parameters.*

Please refer to Technical Note [TN021 Power-On Procedure](#) for more information.

	<b>± 2g / 4g / 8g Tri-axis Digital Accelerometer Specifications</b>	<b>PART NUMBER:</b> <b>KX126-1063</b> <b>Rev. 1.0</b> <b>22-Jun-17</b>
---	---	---

**Environmental**

Parameters		Units	Min	Typical	Max
Supply Voltage (VDD)	Absolute Limits	V	-0.3	-	3.60
Operating Temperature Range		°C	-40	-	85
Storage Temperature Range		°C	-55	-	150
Mech. Shock (powered and unpowered)		g	-	-	5000 for 0.5ms 10000 for 0.2ms
ESD	HBM	V	-	-	2000

**Table 3:** Environmental Specifications



Caution: ESD Sensitive and Mechanical Shock Sensitive Component, improper handling can cause permanent damage to the device.



These products conform to RoHS Directive 2011/65/EU of the European Parliament and of the Council of the European Union that was issued June 8, 2011. Specifically, these products do not contain any non-exempted amounts of lead, mercury, cadmium, hexavalent chromium, polybrominated biphenyls (PBB) or polybrominated diphenyl ethers (PBDE) above the maximum concentration values (MCV) by weight in any of its homogenous materials.

Homogenous materials are “of uniform composition throughout”. The MCV for lead, mercury, hexavalent chromium, PBB, and PBDE is 0.10%. The MCV for cadmium is 0.010%.

Applicable Exemption: 7C-I - *Electrical and electronic components containing lead in a glass or ceramic other than dielectric ceramic in capacitors (piezoelectronic devices) or in a glass or ceramic matrix compound.*



These products are also in conformance with REACH Regulation No 1907/2006 of the European Parliament and of the Council that was issued Dec. 30, 2011. They do not contain any Substances of Very High Concern (SVHC-161) as identified by the European Chemicals Agency as of 17 December 2014.



This product is halogen-free per IEC 61249-2-21. Specifically, the materials used in this product contain a maximum total halogen content of 1500 ppm with less than 900-ppm bromine and less than 900-ppm chlorine.

**Soldering**

Soldering recommendations are available upon request or from [www.kionix.com](http://www.kionix.com).

	<b>± 2g / 4g / 8g Tri-axis Digital Accelerometer Specifications</b>	<b>PART NUMBER:</b> <b>KX126-1063</b> <b>Rev. 1.0</b> <b>22-Jun-17</b>
---	---	---

## Terminology

### g

A unit of acceleration equal to the acceleration of gravity at the earth's surface.

$$1g = 9.8 \frac{m}{s^2}$$

One thousandth of a g (0.0098 m/ s<sup>2</sup>) is referred to as 1 milli-g (1 mg).

### Sensitivity

The sensitivity of an accelerometer is the change in output per unit of input acceleration at nominal VDD and temperature. The term is essentially the gain of the sensor expressed in counts per g (counts/g) or LSB's per g (LSB/g). Occasionally, sensitivity is expressed as a resolution, i.e. milli-g per LSB (mg/LSB) or milli-g per count (mg/count). Sensitivity for a given axis is determined by measurements of the formula:

$$Sensitivity = \frac{(Output @ +1g - Output @ -1g)}{2g}$$

The sensitivity tolerance describes the range of sensitivities that can be expected from a large population of sensors at room temperature and over life. When the temperature deviates from room temperature (25°C), the sensitivity will vary by the amount shown in Table 1.

### Zero-g offset

Zero-g offset or 0-g offset describes the actual output of the accelerometer when no acceleration is applied. Ideally, the output would always be in the middle of the dynamic range of the sensor (content of the OUTX, OUTY, OUTZ registers = 00, expressed as a 2's complement number). However, because of mismatches in the sensor, calibration errors, and mechanical stress, the output can deviate from 00. This deviation from the ideal value is called 0-g offset. The zero-g offset tolerance describes the range of 0-g offsets of a population of sensors over the operating temperature range.

### Self-test

Self-test allows a functional test of the sensor without applying a physical acceleration to it. When activated, an electrostatic force is applied to the sensor, simulating an input acceleration. The sensor outputs respond accordingly. If the output signals change within the amplitude specified in Table 1, then the sensor is working properly and the parameters of the interface chip are within the defined specifications.

	<b>± 2g / 4g / 8g Tri-axis Digital Accelerometer Specifications</b>	<b>PART NUMBER:</b> <b>KX126-1063</b> <b>Rev. 1.0</b> <b>22-Jun-17</b>
---	---	---

## Functionality

### Sense element

The sense element is fabricated using Kionix’s proprietary plasma micromachining process technology. This process technology allows Kionix to create mechanical silicon structures which are essentially mass-spring systems that move in the direction of the applied acceleration. Acceleration sensing is based on the principle of a differential capacitance arising from the acceleration-induced motion. Capacitive plates on the moving mass move relative to fixed capacitive plates anchored to the substrate. The sense element is hermetically sealed at the wafer level by bonding a second silicon lid wafer to the device using a glass frit.

### ASIC interface

A separate ASIC device packaged with the sense element provides all of the signal conditioning and communication with the sensor. The complete measurement chain is composed by a low-noise capacitance to voltage amplifier which converts the differential capacitance of the MEMS sensor into an analog voltage that is sent through an analog-to-digital converter. The acceleration data may be accessed through the I<sup>2</sup>C digital communications provided by the ASIC. In addition, the ASIC contains all of the logic to allow the user to choose data rates, g-ranges, filter settings, and interrupt logic. Plus, there are two programmable state machines which allow the user to create unique embedded functions based on changes in acceleration.

### Factory calibration

Kionix trims the offset and sensitivity of each accelerometer by adjusting gain (sensitivity) and 0-g offset trim codes stored in nonvolatile memory (OTP). Additionally, all functional register default values are also programmed into the nonvolatile memory. Every time the device is turned on or a software reset command is issued, the trimming parameters and default register values are downloaded into the volatile registers to be used during active operation. This allows the device to function without further calibration.



# ± 2g / 4g / 8g Tri-axis Digital Accelerometer Specifications

**PART NUMBER:**  
**KX126-1063**  
**Rev. 1.0**  
**22-Jun-17**

## Application Schematic

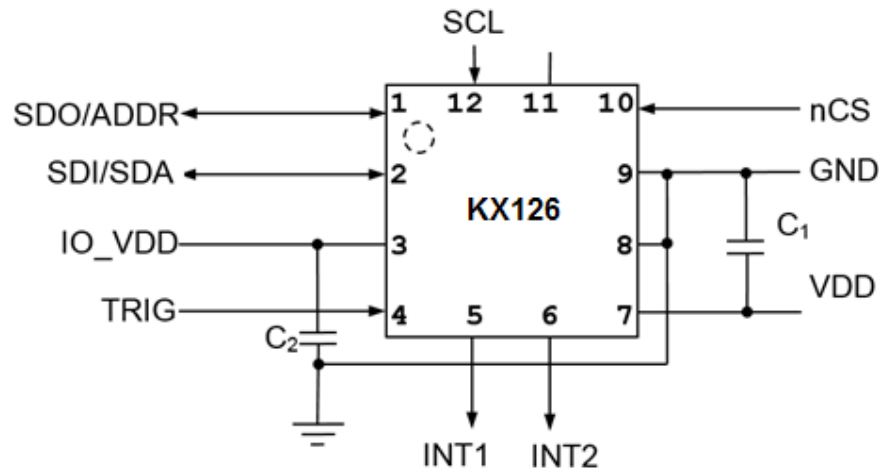

## Pin Descriptions

Pin	Name	Description
1	SDO/ADDR	Serial Data Out pin during 4 wire SPI communication and part of the device address during I <sup>2</sup> C communication. Do not leave floating.
2	SDI/SDA	SPI Data input / I <sup>2</sup> C Serial Data
3	IO_VDD	The power supply input for the I/O. Optionally decouple this pin to ground with a 0.1uF ceramic capacitor.
4	TRIG	Trigger pin for FIFO buffer control. Connect to GND when not using external trigger option
5	INT1	Physical Interrupt 1. Leave floating if not used.
6	INT2	Physical Interrupt 2. Leave floating if not used.
7	VDD	The power supply input. Decouple this pin to ground with a 0.1uF ceramic capacitor.
8	GND	Ground
9	GND	Ground
10	nCS	Chip Select (active LOW) for SPI communication. Connect to IO_VDD for I <sup>2</sup> C communication. Do not leave floating.
11	NC	Not Internally Connected – Can be connected to VDD, IO_VDD, GND or leave floating.
12	SCLK/SCL	SPI and I <sup>2</sup> C Serial Clock

**Table 4:** Pin Description



# ± 2g / 4g / 8g Tri-axis Digital Accelerometer Specifications

**PART NUMBER:**  
**KX126-1063**  
**Rev. 1.0**  
**22-Jun-17**

## Package Dimensions and Orientation

### Dimensions

2 x 2 x 0.9 mm LGA

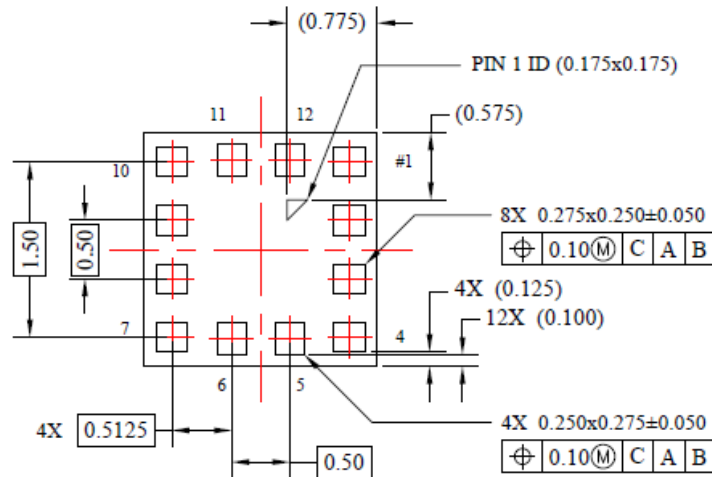
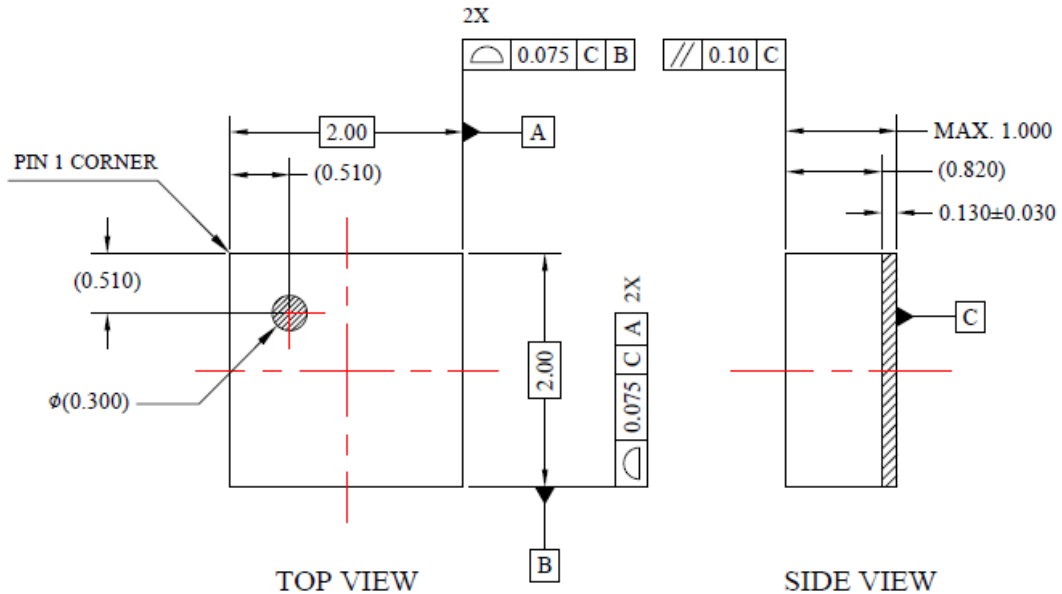

**BOTTOM VIEW**

### NOTES:

1. THE DIMENSIONS IN PARENTHESIS ARE REFERENCE.
2. ALL DIMENSIONS IN MILLIMETERS(MM).

All dimensions and tolerances conform to ASME Y14.5M-1994



# ± 2g / 4g / 8g Tri-axis Digital Accelerometer Specifications

**PART NUMBER:**  
**KX126-1063**  
 Rev. 1.0  
 22-Jun-17

## Orientation

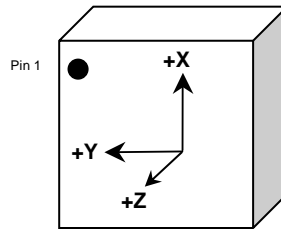

When device is accelerated in +X, +Y or +Z direction, the corresponding output will increase.

### Static X/Y/Z Output Response versus Orientation to Earth's surface (1g): GSEL1=0, GSEL0=0 (± 2g)

Position	1		2		3		4		5		6	
Diagram									Top  Bottom		Bottom  Top	
Resolution (bits)	16	8	16	8	16	8	16	8	16	8	16	8
X (counts)	16384	64	0	0	-16384	-64	0	0	0	0	0	0
Y (counts)	0	0	-16384	-64	0	0	16384	64	0	0	0	0
Z (counts)	0	0	0	0	0	0	0	0	16384	64	-16384	-64
X-Polarity	+		0		-		0		0		0	
Y-Polarity	0		-		0		+		0		0	
Z-Polarity	0		0		0		0		+		-	

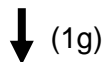

Earth's Surface



# ± 2g / 4g / 8g Tri-axis Digital Accelerometer Specifications

**PART NUMBER:**  
**KX126-1063**  
 Rev. 1.0  
 22-Jun-17

**Static X/Y/Z Output Response versus Orientation to Earth's surface (1g):**  
 GSEL1=0, GSEL0=1 (± 4g)

Position	1		2		3		4		5		6	
Diagram									Top  Bottom		Bottom  Top	
Resolution (bits)	16	8	16	8	16	8	16	8	16	8	16	8
X (counts)	8192	32	0	0	-8192	-32	0	0	0	0	0	0
Y (counts)	0	0	-8192	-32	0	0	8192	32	0	0	0	0
Z (counts)	0	0	0	0	0	0	0	0	8192	32	-8192	-32
X-Polarity	+		0		-		0		0		0	
Y-Polarity	0		-		0		+		0		0	
Z-Polarity	0		0		0		0		+		-	

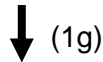

Earth's Surface

**Static X/Y/Z Output Response versus Orientation to Earth's surface (1g):**  
 GSEL1=1, GSEL0=0 (± 8g)

Position	1		2		3		4		5		6	
Diagram									Top  Bottom		Bottom  Top	
Resolution (bits)	16	8	16	8	16	8	16	8	16	8	16	8
X (counts)	4096	16	0	0	-4096	-16	0	0	0	0	0	0
Y (counts)	0	0	-4096	-16	0	0	4096	16	0	0	0	0
Z (counts)	0	0	0	0	0	0	0	0	4096	16	-4096	-16
X-Polarity	+		0		-		0		0		0	
Y-Polarity	0		-		0		+		0		0	
Z-Polarity	0		0		0		0		+		-	



Earth's Surface



	<b>± 2g / 4g / 8g Tri-axis Digital Accelerometer Specifications</b>	<b>PART NUMBER:</b> <b>KX126-1063</b> <b>Rev. 1.0</b> <b>22-Jun-17</b>
---	---	---

## Digital Interface

The Kionix KX126 digital accelerometer can communicate via the I<sup>2</sup>C and SPI digital serial interface protocols. This allows for easy system integration by eliminating analog-to-digital converter requirements and by providing direct communication with system micro-controllers.

The serial interface terms and descriptions as indicated in Table 5 below will be observed throughout this document.

Term	Description
Transmitter	The device that transmits data to the bus.
Receiver	The device that receives data from the bus.
Master	The device that initiates a transfer, generates clock signals, and terminates a transfer.
Slave	The device addressed by the Master.

**Table 5:** Serial Interface Terminologies

## I<sup>2</sup>C Serial Interface

As previously mentioned, the KX126 can communicate on an I<sup>2</sup>C bus. I<sup>2</sup>C is primarily used for synchronous serial communication between a Master device and one or more Slave devices. The Master, typically a micro controller, provides the serial clock signal and addresses Slave devices on the bus. The KX126 always operates as a Slave device during standard Master-Slave I<sup>2</sup>C operation.

I<sup>2</sup>C is a two-wire serial interface that contains a Serial Clock (SCL) line and a Serial Data (SDA) line. SCL is a serial clock that is provided by the Master, but can be held low by any Slave device, putting the Master into a wait condition. SDA is a bi-directional line used to transmit and receive data to and from the interface. Data is transmitted MSB (Most Significant Bit) first in 8-bit per byte format, and the number of bytes transmitted per transfer is unlimited. The I<sup>2</sup>C bus is considered free when both lines are high.

The I<sup>2</sup>C interface is compliant with high-speed mode, fast mode and standard mode I<sup>2</sup>C protocols.

	<b>± 2g / 4g / 8g Tri-axis Digital Accelerometer Specifications</b>	<b>PART NUMBER:</b> <b>KX126-1063</b> <b>Rev. 1.0</b> <b>22-Jun-17</b>
---	---	---

## I<sup>2</sup>C Operation

Transactions on the I<sup>2</sup>C bus begin after the Master transmits a start condition (S), which is defined as a high-to-low transition on the data line while the SCL line is held high. The bus is considered busy after this condition. The next byte of data transmitted after the start condition contains the Slave Address (SAD) in the seven MSBs (Most Significant Bits), and the LSB (Least Significant Bit) tells whether the Master will be receiving data '1' from the Slave or transmitting data '0' to the Slave. When a Slave Address is sent, each device on the bus compares the seven MSBs with its internally stored address. If they match, the device considers itself addressed by the Master. The KX126 Slave Address is comprised of a user programmable part, a factory programmable part, and a fixed part, which allows for connection of multiple accelerometers to the same I<sup>2</sup>C bus. The Slave Address associated with the KX126 is 00111YX, where the user programmable bit X, is determined by the assignment of ADDR (pin 1) to GND or IO\_VDD. Also, the factory programmable bit Y is set at the factory. **For KX126-1063, the factory programmable bit Y is fixed to 1** (contact your Kionix sales representative for list of available devices). Table 6 lists possible I<sup>2</sup>C addresses for KX126-1063. As a result, up to four accelerometers can be implemented on a shared I<sup>2</sup>C bus as shown in Figure 2 (e.g. two KX126 accelerometers and two other accelerometers with factory programmable bit Y set to 0).

Description	Address Pad	7-bit Address	Address	<7>	<6>	<5>	<4>	<3>	Y	X	<0>
									<2>	<1>	
I2C Wr	GND	0x1E	0x3C	0	0	1	1	1	1	0	0
I2C Rd	GND	0x1E	0x3D	0	0	1	1	1	1	0	1
I2C Wr	IO_VDD	0x1F	0x3E	0	0	1	1	1	1	1	0
I2C Rd	IO_VDD	0x1F	0x3F	0	0	1	1	1	1	1	1

**Table 6:** I<sup>2</sup>C Slave Addresses for KX126-1063

It is mandatory that receiving devices acknowledge (ACK) each transaction. Therefore, the transmitter must release the SDA line during this ACK pulse. The receiver then pulls the data line low so that it remains stable low during the high period of the ACK clock pulse. A receiver that has been addressed, whether it is Master or Slave, is obliged to generate an ACK after each byte of data has been received. To conclude a transaction, the Master must transmit a stop condition (P) by transitioning the SDA line from low to high while SCL is high. The I<sup>2</sup>C bus is now free. Note that if the KX126 is accessed through I<sup>2</sup>C protocol before the startup is finished a NACK signal is sent.



# ± 2g / 4g / 8g Tri-axis Digital Accelerometer Specifications

**PART NUMBER:**  
**KX126-1063**  
**Rev. 1.0**  
**22-Jun-17**

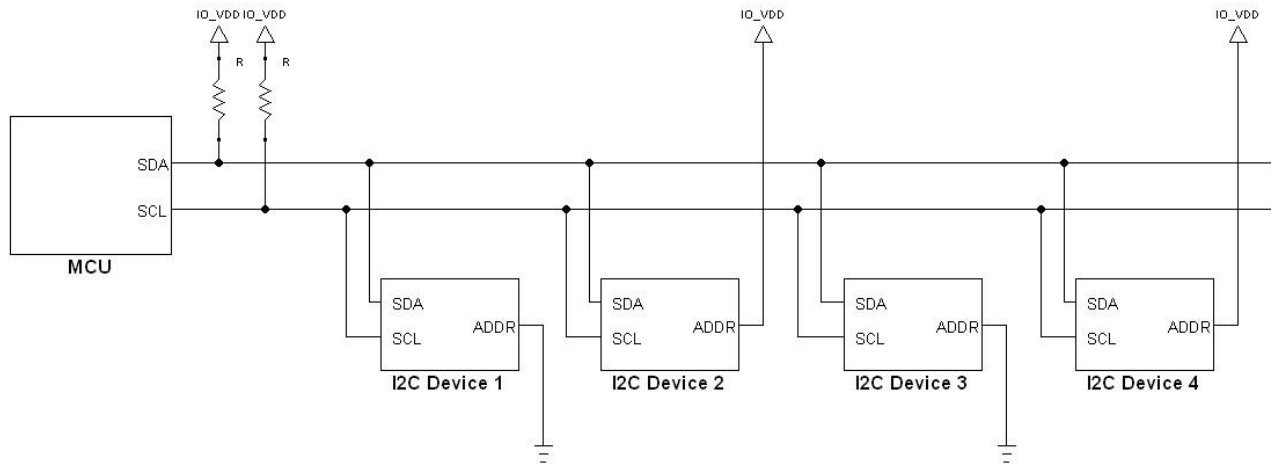

I2C Device	Part Number	ADDR Pin	Slave Address	Bit Y (Bit 1 in 7-bit address)
1	KX126-1063	GND	0x1E	Factory Set to 1
2	KX126-1063	IO_VDD	0x1F	Factory Set to 1
3	*KXMMM	GND	0x1C	Factory Set to 0
4	*KXMMM	IO_VDD	0x1D	Factory Set to 0

\* KXMMM – contact Kionix sales representative for list of compatible devices

**Figure 2: Multiple KX126 Accelerometers on a Shared I<sup>2</sup>C Bus**

	<b>± 2g / 4g / 8g Tri-axis Digital Accelerometer Specifications</b>	<b>PART NUMBER:</b> <b>KX126-1063</b> <b>Rev. 1.0</b> <b>22-Jun-17</b>
---	---	---

### Writing to an 8-bit Register

Upon power up, the Master must write to the KX126's control registers to set its operational mode. Therefore, when writing to a control register on the I<sup>2</sup>C bus, as shown Sequence 1 on the following page, the following protocol must be observed: After a start condition, SAD+W transmission, and the KX126 ACK has been returned, an 8-bit Register Address (RA) command is transmitted by the Master. This command is telling the KX126 to which 8-bit register the Master will be writing the data. Since this is I<sup>2</sup>C mode, the MSB of the RA command should always be zero (0). The KX126 acknowledges the RA and the Master transmits the data to be stored in the 8-bit register. The KX126 acknowledges that it has received the data and the Master transmits a stop condition (P) to end the data transfer. The data sent to the KX126 is now stored in the appropriate register. The KX126 automatically increments the received RA commands and, therefore, multiple bytes of data can be written to sequential registers after each Slave ACK as shown in Sequence 2 on the following page.

Note\*\* If a STOP condition is sent on the least significant bit of write data or the following master acknowledge cycle, the last write operation is not guaranteed and it may alter the content of the affected registers

### Reading from an 8-bit Register

When reading data from a KX126 8-bit register on the I<sup>2</sup>C bus, as shown in Sequence 3 on the next page, the following protocol must be observed: The Master first transmits a start condition (S) and the appropriate Slave Address (SAD) with the LSB set at '0' to write. The KX126 acknowledges and the Master transmits the 8-bit RA of the register it wants to read. The KX126 again acknowledges, and the Master transmits a repeated start condition (Sr). After the repeated start condition, the Master addresses the KX126 with a '1' in the LSB (SAD+R) to read from the previously selected register. The Slave then acknowledges and transmits the data from the requested register. The Master does not acknowledge (NACK) it received the transmitted data, but transmits a stop condition to end the data transfer. Note that the KX126 automatically increments through its sequential registers, allowing data to be read from multiple registers following a single SAD+R command as shown below in Sequence 4 on the following page. Reading data from a buffer read register is a special case because if register address (RA) is set to buffer read register (BUF\_READ) in Sequence 4, the register auto-increment feature is automatically disabled. Instead, the Read Pointer will increment to the next data in the buffer, thus allowing reading multiple bytes of data from the buffer using a single SAD+R command.

Note\*\* Accelerometer's output data should be read in a single transaction using the auto-increment feature to prevent output data from being updated prior to intended completion of the read transaction.

### Data Transfer Sequences

The following information clearly illustrates the variety of data transfers that can occur on the I<sup>2</sup>C bus and how the Master and Slave interact during these transfers. Table 7 defines the I<sup>2</sup>C terms used during the data transfers.

Term	Definition
S	Start Condition
Sr	Repeated Start Condition
SAD	Slave Address
W	Write Bit
R	Read Bit
ACK	Acknowledge
NACK	Not Acknowledge
RA	Register Address
Data	Transmitted/Received Data
P	Stop Condition

**Table 7: I<sup>2</sup>C Terms**

**Sequence 1.** The Master is writing one byte to the Slave.

Master	S	SAD + W		RA		DATA		P
Slave			ACK		ACK		ACK	

**Sequence 2.** The Master is writing multiple bytes to the Slave.

Master	S	SAD + W		RA		DATA		DATA		P
Slave			ACK		ACK		ACK		ACK	

**Sequence 3.** The Master is receiving one byte of data from the Slave.

Master	S	SAD + W		RA		Sr	SAD + R			NACK	P
Slave			ACK		ACK			ACK	DATA		

**Sequence 4.** The Master is receiving multiple bytes of data from the Slave.

Master	S	SAD + W		RA		Sr	SAD + R			ACK		NACK	P
Slave			ACK		ACK			ACK	DATA		DATA		

	<b>± 2g / 4g / 8g Tri-axis Digital Accelerometer Specifications</b>	<b>PART NUMBER:</b> <b>KX126-1063</b> <b>Rev. 1.0</b> <b>22-Jun-17</b>
---	---	---

### HS-mode

To enter the 3.4MHz high speed mode of communication, the device must receive the following sequence of conditions from the master: a Start condition followed by a Master code (00001XXX) and a Master Non-acknowledge. Once recognized, the device switches to HS-mode communication. Read/write data transfers then proceed as described in the sequences above. Devices return to the FS-mode after a STOP occurrence on the bus.

**Sequence 5.** HS-mode data transfer of the Master writing multiple bytes to the Slave.

Speed	FS-mode			HS-mode							FS-mode	
Master	S	M-code	NACK	Sr	SAD + W		RA		DATA		P	
Slave						ACK		ACK		ACK		

n bytes + ack.

**Sequence 6.** HS-mode data transfer of the Master receiving multiple bytes of data from the Slave.

Speed	FS-mode			HS-mode				
Master	S	M-code	NACK	Sr	SAD + W		RA	
Slave						ACK		ACK

Speed	HS-mode							FS-mode
Master	Sr	SAD + R					NACK	P
Slave			ACK	DATA	ACK	DATA		

(n-1) bytes + ack.



# ± 2g / 4g / 8g Tri-axis Digital Accelerometer Specifications

**PART NUMBER:**

**KX126-1063**

**Rev. 1.0**

**22-Jun-17**

## I<sup>2</sup>C Timing Diagram

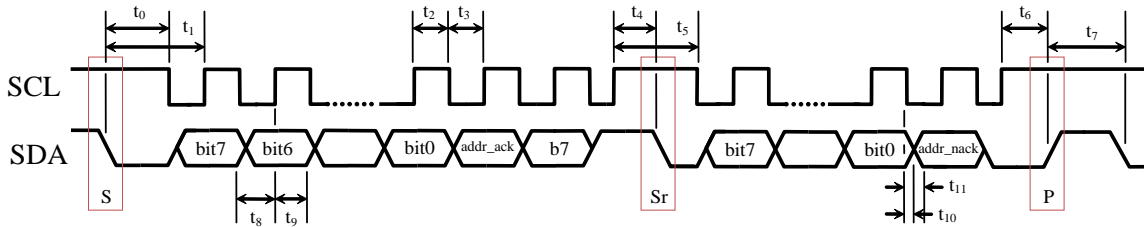

Number	Description	MIN	MAX	Units
$t_0$	SDA low to SCL low transition (Start event)	50	-	ns
$t_1$	SDA low to first SCL rising edge	100	-	ns
$t_2$	SCL pulse width: high	100	-	ns
$t_3$	SCL pulse width: low	100	-	ns
$t_4$	SCL high before SDA falling edge (Start Repeated)	50	-	ns
$t_5$	SCL pulse width: high during a S/Sr/P event	100	-	ns
$t_6$	SCL high before SDA rising edge (Stop)	50	-	ns
$t_7$	SDA pulse width: high	25	-	ns
$t_8$	SDA valid to SCL rising edge	50	-	ns
$t_9$	SCL rising edge to SDA invalid	50	-	ns
$t_{10}$	SCL falling edge to SDA valid (when slave is transmitting)	-	100	ns
$t_{11}$	SCL falling edge to SDA invalid (when slave is transmitting)	0	-	ns
Note	Recommended I <sup>2</sup> C CLK	2.5	-	μs

**Table 8: I<sup>2</sup>C Timing (Fast Mode)**

	<b>± 2g / 4g / 8g Tri-axis Digital Accelerometer Specifications</b>	<b>PART NUMBER:</b> <b>KX126-1063</b> <b>Rev. 1.0</b> <b>22-Jun-17</b>
---	---	---

## SPI Communications

### 4-Wire SPI Interface

The KX126 also utilizes an integrated 4-Wire Serial Peripheral Interface (SPI) for digital communication. The SPI interface is primarily used for synchronous serial communication between one Master device and one or more Slave devices. The Master, typically a micro controller, provides the SPI clock signal (SCLK) and determines the state of Chip Select (nCS). The KX126 always operates as a Slave device during standard Master-Slave SPI operation.

4-wire SPI is a synchronous serial interface that uses two control and two data lines. With respect to the Master, the Serial Clock output (SCLK), the Data Output (SDI or MOSI) and the Data Input (SDO or MISO) are shared among the Slave devices. The Master generates an independent Chip Select (nCS) for each Slave device that goes low at the start of transmission and goes back high at the end. The Slave Data Output (SDO) line, remains in a high-impedance (hi-z) state when the device is not selected, so it does not interfere with any active devices. This allows multiple Slave devices to share a master SPI port as shown in Figure 3 below.

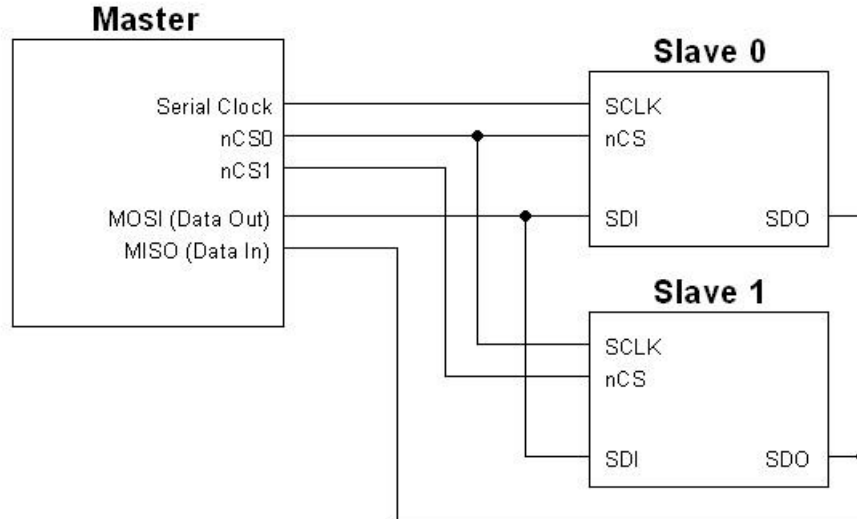

**Figure 3. 4-wire SPI Connections**





# ± 2g / 4g / 8g Tri-axis Digital Accelerometer Specifications

**PART NUMBER:**  
**KX126-1063**  
**Rev. 1.0**  
**22-Jun-17**

## 4-Wire SPI Timing Diagram

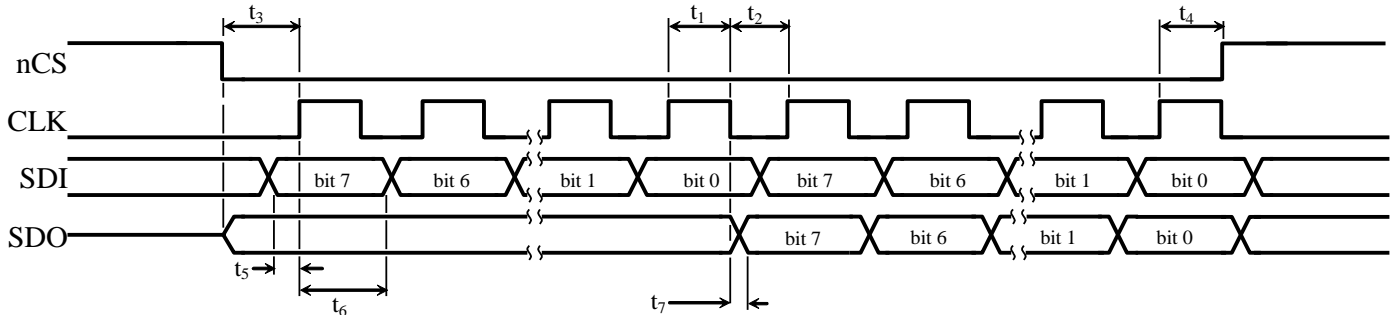

Number	Description	MIN	MAX	Units
t <sub>1</sub>	CLK pulse width: HIGH	45		ns
t <sub>2</sub>	CLK pulse width: LOW	45		ns
t <sub>3</sub>	nCS LOW to first CLK rising edge	20		ns
t <sub>4</sub>	nCS LOW after the final CLK rising edge to nCS HIGH	20		ns
t <sub>5</sub>	SDI valid to CLK rising edge	10		ns
t <sub>6</sub>	CLK rising edge to SDI invalid	10		ns
t <sub>7</sub>	CLK falling edge to SDO valid		35	ns

**Table 9: 4-Wire SPI Timing**

### Notes

1. t<sub>7</sub> is only present during reads.
2. Timings are for VDD of 1.8V to 3.6V with 1kΩ pull-up resistor and maximum 20pF load capacitor on SDO.



# ± 2g / 4g / 8g Tri-axis Digital Accelerometer Specifications

**PART NUMBER:**  
**KX126-1063**  
**Rev. 1.0**  
**22-Jun-17**

## 4-Wire Read and Write Registers

The registers embedded in the KX126 accelerometer have 8-bit addresses. Upon power up, the Master must write to the accelerometer's control registers to set its operational mode. On the falling edge of nCS, a 2-byte command is written to the appropriate control register. The first byte initiates the write to the appropriate register, and is followed by the user-defined, data byte. The MSB (Most Significant Bit) of the register address byte will indicate "0" when writing to the register and "1" when reading from the register. This operation occurs over 16 clock cycles. All commands are sent MSB first. **The host must return nCS high for at least one clock cycle before the next data request.** However, when data is being read from a buffer read register (BUF\_READ), the nCS signal can remain low until the buffer is read. Figure 4 below shows the timing diagram for carrying out an 8-bit register write operation.

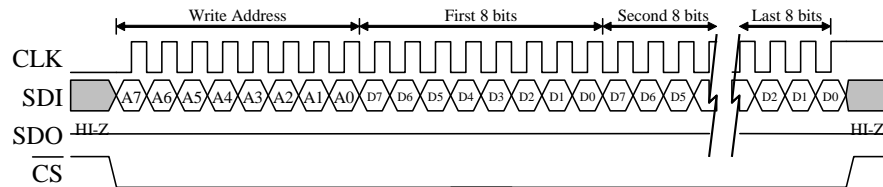

**Figure 4: Timing Diagram for 8-Bit Register Write Operation**

In order to read an 8-bit register, an 8-bit register address must be written to the accelerometer to initiate the read. The MSB of this register address byte will indicate "0" when writing to the register and "1" when reading from the register. Upon receiving the address, the accelerometer returns the 8-bit data stored in the addressed register. This operation also occurs over 16 clock cycles. All returned data is sent MSB first, and the host must return nCS high for at least one clock cycle before the next data request. Figure 5 shows the timing diagram for an 8-bit register read operation.

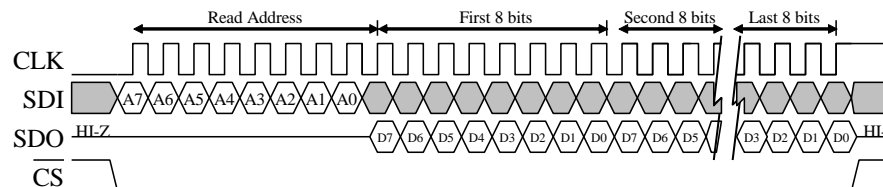

**Figure 5: Timing Diagram for 8-Bit Register Read Operation**



# ± 2g / 4g / 8g Tri-axis Digital Accelerometer Specifications

**PART NUMBER:**  
**KX126-1063**  
**Rev. 1.0**  
**22-Jun-17**

## 3-Wire SPI Interface

The KX126 also utilizes an integrated 3-Wire Serial Peripheral Interface (SPI) for digital communication. 3-wire SPI is a synchronous serial interface that uses two control lines and one data line. With respect to the Master, the Serial Clock output (SCLK), the Data Output/Input (SDI) are shared among the Slave devices. The Master generates an independent Chip Select (nCS) for each Slave device that goes low at the start of transmission and goes back high at the end. This allows multiple Slave devices to share a master SPI port as shown in Figure 6 below.

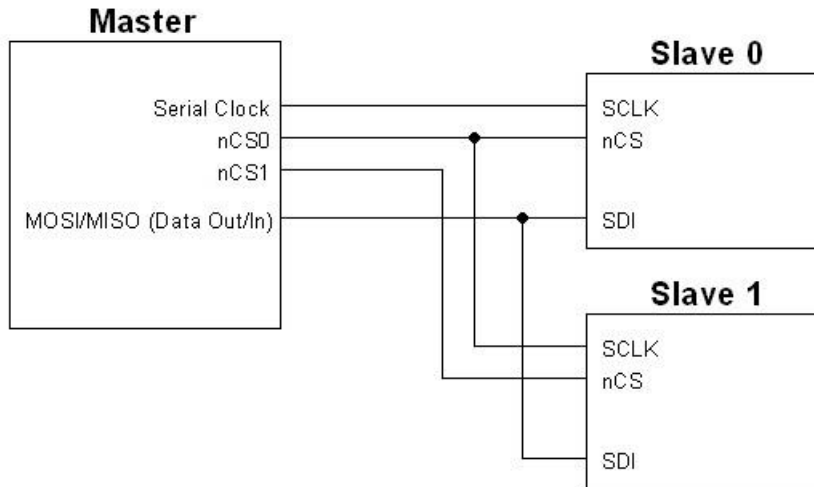

**Figure 6: KX126 3-wire SPI Connections**



# ± 2g / 4g / 8g Tri-axis Digital Accelerometer Specifications

**PART NUMBER:**  
**KX126-1063**  
**Rev. 1.0**  
**22-Jun-17**

## 3-Wire SPI Timing Diagram

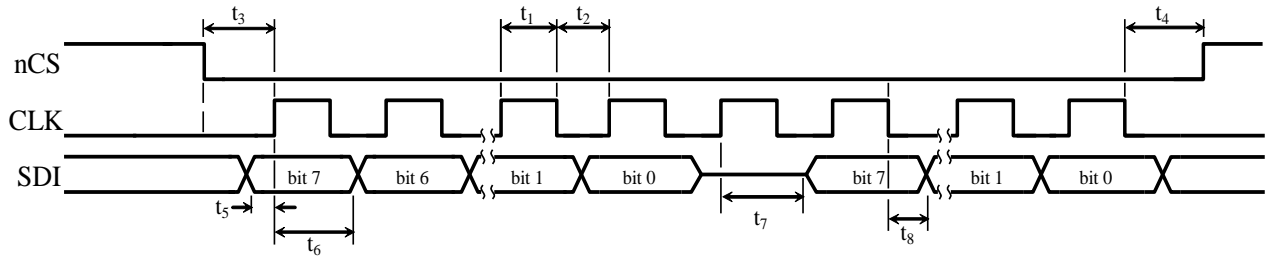

Number	Description	MIN	MAX	Units
$t_1$	CLK pulse width: high	45	-	ns
$t_2$	CLK pulse width: low	45	-	ns
$t_3$	nCS low to first CLK rising edge	20	-	ns
$t_4$	nCS low after the final CLK falling edge to nCS high	20	-	ns
$t_5$	SDI valid to CLK rising edge	10	-	ns
$t_6$	CLK rising edge to SDI input invalid	10	-	ns
$t_7$	CLK extra clock cycle rising edge to SDI output becomes valid	-	-	ns
$t_8$	CLK falling edge to SDI output becomes valid	-	35	ns

**Table 10: 3-Wire SPI Timing**

### Notes

- $t_7$  and  $t_8$  are only present during reads
- Timings are for VDD of 1.8V to 3.6V with 1k $\Omega$  pull-up resistor and maximum 20pF load capacitor on SDI.
- The SDO/ADDR pin is configured in a high-impedance input-state, and must be externally tied to GND or IO\_VDD

	<b>± 2g / 4g / 8g Tri-axis Digital Accelerometer Specifications</b>	<b>PART NUMBER:</b> <b>KX126-1063</b> <b>Rev. 1.0</b> <b>22-Jun-17</b>
---	---	---

### 3-Wire Read and Write Registers

The registers embedded in the KX126 accelerometer have 8-bit addresses. Upon power up, the Master must write to the accelerometer’s control registers to set its operational mode. On the falling edge of nCS, a 2-byte command is written to the appropriate control register. The first byte initiates the write to the appropriate register, and is followed by the user-defined, data byte. The MSB (Most Significant Bit) of the register address byte will indicate “0” when writing to the register and “1” when reading from the register. A read operation occurs over 17 clock cycles and a write operation occurs over 16 clock cycles. All commands are sent MSB first. **The host must return nCS high for at least one clock cycle before the next data request.** However, when data is being read from a buffer read register (BUF\_READ), the nCS signal can remain low until the buffer is read. Figure 7 below shows the timing diagram for carrying out an 8-bit register write operation.

NOTE\*\* If a STOP condition is sent on the least significant bit of write data or the following master acknowledge cycle, the last write operation is not guaranteed and it would cause unexpected register write.

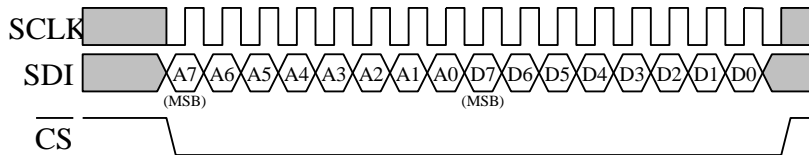

**Figure 7:** Timing Diagram for 8-Bit Register Write Operation

In order to read an 8-bit register, an 8-bit register address must be written to the accelerometer to initiate the read. The MSB of this register address byte will indicate “0” when writing to the register and “1” when reading from the register. Upon receiving the address, the accelerometer returns the 8-bit data stored in the addressed register. **For 3-wire read operations, one extra clock cycle between the address byte and the data output byte is required.** Therefore, this operation occurs over 17 clock cycles. All returned data is sent MSB first, and the host must return nCS high for at least one clock cycle before the next data request. Figure 8 shows the timing diagram for an 8-bit register read operation.

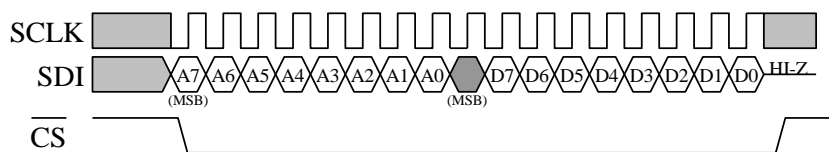

**Figure 8:** Timing Diagram for 8-Bit Register Read Operation



# ± 2g / 4g / 8g Tri-axis Digital Accelerometer Specifications

**PART NUMBER:**  
**KX126-1063**  
**Rev. 1.0**  
**22-Jun-17**

## Embedded Registers

The KX126 has 78 embedded 8-bit registers that are accessible by the user. This section contains the addresses for all embedded registers and describes bit functions of each register. Table 11 below provides a listing of the accessible 8-bit registers and their addresses.

Address	Register Name	R/W	Address	Register Name	R/W	Address	Register Name	R/W
00	MAN_ID	R	1C	CNTL3 <sup>3</sup>	R/W	38-3B	Kionix Reserved <sup>2</sup>	
01	PART_ID	R	1D	CNTL4 <sup>3</sup>	R/W	3C	WUPTH <sup>3</sup>	R/W
02	XHPL <sup>1</sup>	R	1E	CNTL5	R/W	3D	BTSWUPTH <sup>3</sup>	R/W
03	XHPH <sup>1</sup>	R	1F	ODCNTL <sup>3</sup>	R/W	3E	BTSTH <sup>3</sup>	R/W
04	YHPL <sup>1</sup>	R	20	INC1 <sup>3</sup>	R/W	3F	BTSC <sup>3</sup>	R/W
05	YHPH <sup>1</sup>	R	21	INC2 <sup>3</sup>	R/W	40	WUFC <sup>3</sup>	R/W
06	ZHPL <sup>1</sup>	R	22	INC3 <sup>3</sup>	R/W	41	PED_WM_L <sup>3</sup>	R/W
07	ZHPH <sup>1</sup>	R	23	INC4 <sup>3</sup>	R/W	42	PED_WM_H <sup>3</sup>	R/W
08	XOUTL	R	24	INC5 <sup>3</sup>	R/W	43	PED_CNTL1 <sup>3</sup>	R/W
09	XOUTH	R	25	INC6 <sup>3</sup>	R/W	44	PED_CNTL2 <sup>3</sup>	R/W
0A	YOUTL	R	26	INC7 <sup>3</sup>	R/W	45	PED_CNTL3 <sup>3</sup>	R/W
0B	YOUTH	R	27	TILT_TIMER <sup>3</sup>	R/W	46	PED_CNTL4 <sup>3</sup>	R/W
0C	ZOUTL	R	28	TDTRC <sup>3</sup>	R/W	47	PED_CNTL5 <sup>3</sup>	R/W
0D	ZOUTH	R	29	TDTC <sup>3</sup>	R/W	48	PED_CNTL6 <sup>3</sup>	R/W
0E	PED_STPL	R	2A	TTH <sup>3</sup>	R/W	49	PED_CNTL7 <sup>3</sup>	R/W
0F	PED_STPH	R	2B	TTL <sup>3</sup>	R/W	4A	PED_CNTL8 <sup>3</sup>	R/W
10	COTR	R	2C	FTD <sup>3</sup>	R/W	4B	PED_CNTL9 <sup>3</sup>	R/W
11	WHO_AM_I	R	2D	STD <sup>3</sup>	R/W	4C	PED_CNTL10 <sup>3</sup>	R/W
12	TSCP	R	2E	TLT <sup>3</sup>	R/W	4D	SELF_TEST	W
13	TSPP	R	2F	TWS <sup>3</sup>	R/W	4E - 59	Kionix Reserved <sup>2</sup>	
14	INS1	R	30	FFTH <sup>3</sup>	R/W	5A	BUF_CNTL1 <sup>3</sup>	R/W
15	INS2	R	31	FFC <sup>3</sup>	R/W	5B	BUF_CNTL2 <sup>3</sup>	R/W
16	INS3	R	32	FFCNTL <sup>3</sup>	R/W	5C	BUF_STATUS_1	R
17	STAT	R	33	Kionix Reserved <sup>2</sup>		5D	BUF_STATUS_2	R
18	Kionix Reserved <sup>2</sup>		34	TILT_ANGLE_LL <sup>3</sup>	R/W	5E	BUF_CLEAR	W
19	INT_REL	R	35	TILT_ANGLE_HL <sup>3</sup>	R/W	5F	BUF_READ	R
1A	CNTL1 <sup>3</sup>	R/W	36	HYST_SET <sup>3</sup>	R/W			
1B	CNTL2 <sup>3</sup>	R/W	37	LP_CNTL <sup>3</sup>	R/W			

Note<sup>1</sup>: In addition of setting PC=1, HPE in CNTL4 needs to be set high to enable high-pass data outputs

Note<sup>2</sup>: Reserved registers should not be written

Note<sup>3</sup>: When changing the contents of these registers, the PC1 bit in CNTL1 must first be set to "0".

**Table 11: Register Map**



# ± 2g / 4g / 8g Tri-axis Digital Accelerometer Specifications

**PART NUMBER:**  
**KX126-1063**  
**Rev. 1.0**  
**22-Jun-17**

## Register Descriptions

### Accelerometer Outputs

These registers contain up to 16-bits of valid acceleration data for each axis. However, the user may choose to read only the 8 MSB thus reading an effective 8-bit resolution. When BRES = 0 in BUF\_CNTL2 the 8 MSB is the only data recorded in the buffer. The data is updated every user-defined ODR period, is protected from overwrite during each read, and can be converted from digital counts to acceleration (g) per Table 12 below. The register acceleration output binary data is represented in 2's complement format. For example, if N = 16 bits, then the Counts range is from -32768 to 32767, and if N = 8 bits, then the Counts range is from -128 to 127.

16-bit Register Data (2's complement)	Equivalent Counts in decimal	Range = ±2g	Range = ±4g	Range = ±8g
0111 1111 1111 1111	32767	+1.99994g	+3.99988g	+7.99976g
0111 1111 1111 1110	32766	+1.99988g	+3.99976g	+7.99951g
...	...	...	...	...
0000 0000 0000 0001	1	+0.00006g	+0.00012g	+0.00024g
0000 0000 0000 0000	0	0.00000g	0.00000g	0.00000g
1111 1111 1111 1111	-1	-0.00006g	-0.00012g	-0.00024g
...	...	...	...	...
1000 0000 0000 0001	-32767	-1.99994g	-3.99988g	-7.99976g
1000 0000 0000 0000	-32768	-2.00000g	-4.00000g	-8.00000g

8-bit Register Data (2's complement)	Equivalent Counts in decimal	Range = ±2g	Range = ±4g	Range = ±8g
0111 1111	127	+1.9844g	+3.9688g	+7.9375g
0111 1110	126	+1.9688g	+3.9375g	+7.8750g
...	...	...	...	...
0000 0001	1	+0.0156g	+0.0313g	+0.0625g
0000 0000	0	0.0000g	0.0000g	0.0000g
1111 1111	-1	-0.0156g	-0.0313g	-0.0625g
...	...	...	...	...
1000 0001	-127	-1.9844g	-3.9688g	-7.9375g
1000 0000	-128	-2.000g	-4.000g	-8.000g

**Table 12:** Acceleration (g) Calculation

	<b>± 2g / 4g / 8g Tri-axis Digital Accelerometer Specifications</b>	<b>PART NUMBER:</b> <b>KX126-1063</b> <b>Rev. 1.0</b> <b>22-Jun-17</b>
---	---	---

### MAN\_ID

A burst read (reading using the auto-increment) of 4 bytes starting at address 00, returns the manufacturing ID: "K" "i" "o" "n" in ASCII codes "0x4B" "0x69" "0x6F" "0x6E".

R	R	R	R	R	R	R	R
MANID7	MANID6	MANID5	MANID4	MANID3	MANID2	MANID1	MANID0
Bit7	Bit6	Bit5	Bit4	Bit3	Bit2	Bit1	Bit0
Address: 0x00							

### PART\_ID

A burst read (reading using the auto-increment) of 2 bytes starting at address 01, returns Who-Am-I value ("WAI") as the first byte (LSB) and a 2nd byte (MSB) that returns silicon specific ID.

R	R	R	R	R	R	R	R
PARTID7	PARTID6	PARTID5	PARTID4	PARTID3	PARTID2	PARTID1	PARTID0
Bit7	Bit6	Bit5	Bit4	Bit3	Bit2	Bit1	Bit0
Address: 0x01							

Note: A burst read (reading using the auto-increment) of 6 bytes starting at address 00, returns the MAN\_ID followed by the 2 bytes of PART\_ID

### XHP\_L

X-axis high pass filter accelerometer output least significant byte. Data is updated at the ODR frequency determined by OWUF in CNTL3 and is available when HPE bit is set to 1 in CNTL4 register. 2's complement data format is used. Data is protected while reading using auto increment mode.

R	R	R	R	R	R	R	R
XHP7	XHP6	XHP5	XHP4	XHP3	XHP2	XHP1	XHP0
Bit7	Bit6	Bit5	Bit4	Bit3	Bit2	Bit1	Bit0
Address: 0x02							

### XHP\_H

X-axis high pass filter accelerometer output most significant byte. Data is updated at the ODR frequency determined by OWUF in CNTL3 and is available when HPE bit is set to 1 in CNTL4 register. 2's complement data format is used. Data is protected while reading using auto increment mode.

R	R	R	R	R	R	R	R
XHP15	XHP14	XHP13	XHP12	XHP11	XHP10	XHP9	XHP8
Bit7	Bit6	Bit5	Bit4	Bit3	Bit2	Bit1	Bit0
Address: 0x03							





# ± 2g / 4g / 8g Tri-axis Digital Accelerometer Specifications

**PART NUMBER:**  
**KX126-1063**  
**Rev. 1.0**  
**22-Jun-17**

## YHP\_L

Y-axis high pass filter accelerometer output least significant byte. Data is updated at the ODR frequency determined by OWUF in CNTL3 and is available when HPE bit is set to 1 in CNTL4 register. 2's complement data format is used. Data is protected while reading using auto increment mode.

R	R	R	R	R	R	R	R
YHP7	YHP6	YHP5	YHP4	YHP3	YHP2	YHP1	YHP0
Bit7	Bit6	Bit5	Bit4	Bit3	Bit2	Bit1	Bit0
Address: 0x04							

## YHP\_H

Y-axis high pass filter accelerometer output most significant byte. Data is updated at the ODR frequency determined by OWUF in CNTL3 and is available when HPE bit is set to 1 in CNTL4 register. 2's complement data format is used. Data is protected while reading using auto increment mode.

R	R	R	R	R	R	R	R
YHP15	YHP14	YHP13	YHP12	YHP11	YHP10	YHP9	YHP8
Bit7	Bit6	Bit5	Bit4	Bit3	Bit2	Bit1	Bit0
Address: 0x05							

## ZHP\_L

Z-axis high pass filter accelerometer output least significant byte. Data is updated at the ODR frequency determined by OWUF in CNTL3 and is available when HPE bit is set to 1 in CNTL4 register. 2's complement data format is used. Data is protected while reading using auto increment mode.

R	R	R	R	R	R	R	R
ZHP7	ZHP6	ZHP5	ZHP4	ZHP3	ZHP2	ZHP1	ZHP0
Bit7	Bit6	Bit5	Bit4	Bit3	Bit2	Bit1	Bit0
Address: 0x06							

## ZHP\_H

Z-axis high pass filter accelerometer output most significant byte. Data is updated at the ODR frequency determined by OWUF in CNTL3 and is available when HPE bit is set to 1 in CNTL4 register. 2's complement data format is used. Data is protected while reading using auto increment mode.

R	R	R	R	R	R	R	R
ZHP15	ZHP14	ZHP13	ZHP12	ZHP11	ZHP10	ZHP9	ZHP8
Bit7	Bit6	Bit5	Bit4	Bit3	Bit2	Bit1	Bit0
Address: 0x07							



# ± 2g / 4g / 8g Tri-axis Digital Accelerometer Specifications

**PART NUMBER:**  
**KX126-1063**  
**Rev. 1.0**  
**22-Jun-17**

## XOUT\_L

X-axis accelerometer output least significant byte. Data is updated at the ODR frequency determined by OSA in ODCNTL. 2's complement data format is used. Data is protected while reading using auto increment mode.

R	R	R	R	R	R	R	R
XOUT7	XOUT6	XOUT5	XOUT4	XOUT3	XOUT2	XOUT1	XOUT0
Bit7	Bit6	Bit5	Bit4	Bit3	Bit2	Bit1	Bit0
Address: 0x08							

## XOUT\_H

X-axis accelerometer output most significant byte. Data is updated at the ODR frequency determined by OSA in ODCNTL. 2's complement data format is used. Data is protected while reading using auto increment mode.

R	R	R	R	R	R	R	R
XOUT15	XOUT14	XOUT13	XOUT12	XOUT11	XOUT10	XOUT9	XOUT8
Bit7	Bit6	Bit5	Bit4	Bit3	Bit2	Bit1	Bit0
Address: 0x09							

## YOUT\_L

Y-axis accelerometer output least significant byte. Data is updated at the ODR frequency determined by OSA in ODCNTL. 2's complement data format is used. Data is protected while reading using auto increment mode.

R	R	R	R	R	R	R	R
YOUT7	YOUT6	YOUT5	YOUT4	YOUT3	YOUT2	YOUT1	YOUT0
Bit7	Bit6	Bit5	Bit4	Bit3	Bit2	Bit1	Bit0
Address: 0x0A							

## YOUT\_H

Y-axis accelerometer output most significant byte. Data is updated at the ODR frequency determined by OSA in ODCNTL. 2's complement data format is used. Data is protected while reading using auto increment mode.

R	R	R	R	R	R	R	R
YOUT15	YOUT14	YOUT13	YOUT12	YOUT11	YOUT10	YOUT9	YOUT8
Bit7	Bit6	Bit5	Bit4	Bit3	Bit2	Bit1	Bit0
Address: 0x0B							



# ± 2g / 4g / 8g Tri-axis Digital Accelerometer Specifications

**PART NUMBER:**  
**KX126-1063**  
**Rev. 1.0**  
**22-Jun-17**

## ZOUT\_L

Z-axis accelerometer output least significant byte. Data is updated at the ODR frequency determined by OSA in ODCNTL. 2's complement data format is used. Data is protected while reading using auto increment mode.

R	R	R	R	R	R	R	R
ZOUT7	ZOUT6	ZOUT5	ZOUT4	ZOUT3	ZOUT2	ZOUT1	ZOUT0
Bit7	Bit6	Bit5	Bit4	Bit3	Bit2	Bit1	Bit0
Address: 0x0C							

## ZOUT\_H

Z-axis accelerometer output most significant byte. Data is updated at the ODR frequency determined by OSA in ODCNTL. 2's complement data format is used. Data is protected while reading using auto increment mode.

R	R	R	R	R	R	R	R
ZOUT15	ZOUT14	ZOUT13	ZOUT12	ZOUT11	ZOUT10	ZOUT9	ZOUT8
Bit7	Bit6	Bit5	Bit4	Bit3	Bit2	Bit1	Bit0
Address: 0x0D							

## PED\_STP\_L and PED\_STP\_H

16-bit pedometer step counter register. The 16-bit counter value is cleared when PED\_STP\_H register is read. Note, these registers are read-protected, meaning that if read is done at the register update time, the new step will be added to the step counter value read, thus avoiding missing a step during read transaction.

R	R	R	R	R	R	R	R	<b>PED_STP_L</b>
STP7	STP6	STP5	STP4	STP3	STP2	STP1	STP0	
Bit7	Bit6	Bit5	Bit4	Bit3	Bit2	Bit1	Bit0	
Address: 0x0E								

R	R	R	R	R	R	R	R	<b>PED_STP_H</b>
STP15	STP14	STP13	STP12	STP11	STP10	STP9	STP8	
Bit7	Bit6	Bit5	Bit4	Bit3	Bit2	Bit1	Bit0	
Address: 0x0F								

## COTR

Command Test Response: This register can be used to verify proper integrated circuit functionality. It always has a byte value of 0x55 unless the COTC bit in CNTL2 is set. At that point this value is set to 0xAA. The byte value is returned to 0x55 after reading this register and the COTC bit in CNTL2 is cleared.

R	R	R	R	R	R	R	R	Reset Value
COTR7	COTR6	COTR5	COTR4	COTR3	COTR2	COTR1	COTR0	
Bit7	Bit6	Bit5	Bit4	Bit3	Bit2	Bit1	Bit0	01010101
Address: 0x10								

	<b>± 2g / 4g / 8g Tri-axis Digital Accelerometer Specifications</b>	<b>PART NUMBER:</b> <b>KX126-1063</b> <b>Rev. 1.0</b> <b>22-Jun-17</b>
---	---	---

### WHO\_AM\_I

This register can be used for supplier recognition, as it can be factory written to a known byte value. WHO\_AM\_I is the first byte (LSB) of the new PART ID. The default value is 0x38.

R	R	R	R	R	R	R	R	
WAI7	WAI6	WAI5	WAI4	WAI3	WAI2	WAI1	WAI0	Reset Value
Bit7	Bit6	Bit5	Bit4	Bit3	Bit2	Bit1	Bit0	00111000
Address: 0x11								

### Tilt Position Registers

These two registers report previous and current position data that is updated at the user-defined ODR frequency determined by OTP<1:0> in CNTL3. Data is protected during register read. Table 13 describes the reported position for each bit value.

#### TSCP

Current Tilt Position Register.

R	R	R	R	R	R	R	R	
0	0	LE	RI	DO	UP	FD	FU	Reset Value
Bit7	Bit6	Bit5	Bit4	Bit3	Bit2	Bit1	Bit0	00100000
Address: 0x12								

#### TSPP

Previous Tilt Position Register.

R	R	R	R	R	R	R	R	
0	0	LE	RI	DO	UP	FD	FU	Reset Value
Bit7	Bit6	Bit5	Bit4	Bit3	Bit2	Bit1	Bit0	00100000
Address: 0x13								

Bit	Description
LE	Left State (X-)
RI	Right State (X+)
DO	Down State (Y-)
UP	Up State (Y+)
FD	Face-Down State (Z-)
FU	Face-Up State (Z+)

**Table 13: Tilt Position**

	<b>± 2g / 4g / 8g Tri-axis Digital Accelerometer Specifications</b>	<b>PART NUMBER:</b> <b>KX126-1063</b> <b>Rev. 1.0</b> <b>22-Jun-17</b>
---	---	---

### Interrupt Source Registers

These three registers report interrupt state changes. This data is updated when a new interrupt event occurs and each application's result is latched until the interrupt release register is read.

### INS1

This register contains 2 step counter interrupts and contains the tap/double tap axis specific interrupts. Data is updated at the ODR settings determined by OTDT<2:0> in CNTL3.

R	R	R	R	R	R	R	R
STPOVI	STPWMI	TLE	TRI	TDO	TUP	TFD	TFU
Bit7	Bit6	Bit5	Bit4	Bit3	Bit2	Bit1	Bit0
Address: 0x14							

**STPOVI** – Step counter Overflow interrupt. This bit is cleared when the interrupt latch release register (INT\_REL) is read

**STPWMI** – Step counter Watermark interrupt. This bit is cleared when either the PED\_STPL or PED\_STPH step count registers is read.

Bit	Description
<b>TLE</b>	X Negative (X-) Reported
<b>TRI</b>	X Positive (X+) Reported
<b>TDO</b>	Y Negative (Y-) Reported
<b>TUP</b>	Y Positive (Y+) Reported
<b>TFD</b>	Z Negative (Z-) Reported
<b>TFU</b>	Z Positive (Z+) Reported

**Table 14:** Directional Tap™ Reporting

### INS2

This register tells which function caused an interrupt.

R	R	R	R	R	R	R	R
FFS	BFI	WMI	DRDY	TDTS1	TDTS0	STPINCI	TPS
Bit7	Bit6	Bit5	Bit4	Bit3	Bit2	Bit1	Bit0
Address: 0x15							

**FFS** – Free fall. This bit is cleared when the interrupt latch release register (INT\_REL) is read.

FFS = 0 – No Free fall

FFS = 1 – Free fall has activated the interrupt



# ± 2g / 4g / 8g Tri-axis Digital Accelerometer Specifications

**PART NUMBER:**  
**KX126-1063**  
**Rev. 1.0**  
**22-Jun-17**

**BFI** – indicates buffer full interrupt. Automatically cleared when buffer is read.

*BFI = 0 – Buffer is not full*

*BFI = 1 – Buffer is full*

**WMI** – Watermark interrupt, indicates that user-defined buffer's sample threshold (watermark) has been exceeded when in FIFO, FILO, or Stream mode. Not used in Trigger mode. This bit is automatically cleared when buffer is read and the content is below the watermark.

*WMI = 0 – Buffer watermark has not been exceeded*

*WMI = 1 – Buffer watermark has been exceeded*

**DRDY** – indicates that new acceleration data (0x08 to 0x0D) is available. This bit is cleared when acceleration data is read or the interrupt latch release register (INT\_REL) is read.

*DRDY = 0 - new acceleration data not available*

*DRDY = 1 - new acceleration data available*

**TDTS(1,0)** – Status of tap/double tap. This bit is cleared when the interrupt latch release register (INT\_REL) is read.

TDTS1	TDTS0	Event
0	0	No Tap
0	1	Single Tap
1	0	Double Tap
1	1	Do not exist

**STPINCI** – Step counter increment interrupt. This bit is cleared when the interrupt latch release register (INT\_REL) is read.

*STPINCI = 1 – step increment*

*STPINCI = 0 – No step detected*

**TPS** – Tilt Position status.

*TPS = 0 – Position not changed*

*TPS = 1 – Position changed*

## INS3

This register reports the axis and direction of detected motion that triggered the wakeup interrupt.

R	R	R	R	R	R	R	R
WUFS	BTS	XNWU	XPWU	YNWU	YPWU	ZNWU	ZPWU
Bit7	Bit6	Bit5	Bit4	Bit3	Bit2	Bit1	Bit0
Address: 0x16							



# ± 2g / 4g / 8g Tri-axis Digital Accelerometer Specifications

**PART NUMBER:**  
**KX126-1063**  
**Rev. 1.0**  
**22-Jun-17**

**WUFS** – Wake up interrupt. This bit is cleared when the interrupt latch release register (INT\_REL) is read.

WUFS = 1 – Motion is above wake up threshold

WUFS = 0 – Motion is below wake up threshold

**BTS** – Back to sleep interrupt. This bit is cleared when the interrupt latch release register (INT\_REL) is read.

BTS = 1 – Motion is below back to sleep threshold

BTS = 0 – Motion is above back to sleep threshold

Bit	Description
<b>XNWU</b>	X Negative (X-) Reported
<b>XPWU</b>	X Positive (X+) Reported
<b>YNWU</b>	Y Negative (Y-) Reported
<b>YPWU</b>	Y Positive (Y+) Reported
<b>ZNWU</b>	Z Negative (Z-) Reported
<b>ZPWU</b>	Z Positive (Z+) Reported

**Table 15:** Motion Detection™ Reporting

## STAT

Status register - it reports the status of the interrupt.

R	R	R	R	R	R	R	R
0	0	0	INT	0	0	0	WAKE
Bit7	Bit6	Bit5	Bit4	Bit3	Bit2	Bit1	Bit0
Address: 0x17							

**INT** reports the combined (OR) interrupt information according to interrupt setting.

0 = no interrupt event

1 = interrupt event has occurred.

**WAKE** reports the wake/back to sleep state

0 = back-to-sleep state

1 = wake state.

*Note: Wake is the default state at power-up, shown in STAT register. For wake engine only operation, set MAN\_SLEEP bit to 1 in CNTL5 register in order to put KX126 in sleep state for the first time.*



# ± 2g / 4g / 8g Tri-axis Digital Accelerometer Specifications

**PART NUMBER:**  
**KX126-1063**  
 Rev. 1.0  
 22-Jun-17

## INT\_REL

Interrupt latch release. Latched interrupt source information (INS1-INS3) is cleared and physical interrupt latched pin is changed to its inactive state when this register is read. WMI, BFI and STPWMI are not cleared by this command.

R	R	R	R	R	R	R	R
0	0	0	0	0	0	0	0
Bit7	Bit6	Bit5	Bit4	Bit3	Bit2	Bit1	Bit0
Address: 0x19							

## CNTL1

Control register 1. Read/write control register that controls the main feature set.

R/W	R/W	R/W	R/W	R/W	R/W	R/W	R/W	Reset Value
PC1	RES	DRDYE	GSEL1	GSEL0	TDTE	PDE	TPE	00000000
Bit7	Bit6	Bit5	Bit4	Bit3	Bit2	Bit1	Bit0	
Address: 0x1A								

**PC1** controls the operating mode.

*PC1 = 0 - stand-by mode*

*PC1 = 1 - full power or low power mode*

**RES** controls the resolution of the accelerometer output. Note that to change the value of this bit, the PC1 bit must first be set to "0".

*RES = 0 - low power, higher noise mode*

*RES = 1 - higher power, lower noise mode*

**DRDYE** enables the data ready engine. Note that to change the value of this bit, the PC1 bit must first be set to "0".

*DRDYE = 0 - disable*

*DRDYE = 1 - enable*

**GSEL1, GSEL0** selects the acceleration range of the accelerometer outputs per Table 16. Note that to change the value of this bit, the PC1 bit must first be set to "0".

GSEL1	GSEL0	Range
0	0	±2g
0	1	±4g
1	X	±8g

**Table 16:** Selected Acceleration Range





# ± 2g / 4g / 8g Tri-axis Digital Accelerometer Specifications

**PART NUMBER:**  
**KX126-1063**  
**Rev. 1.0**  
**22-Jun-17**

**TDTE** enables the Tap/Double tap engine. Note that to change the value of this bit, the PC1 bit must first be set to “0”.

TDTE = 0 – disable  
 TDTE = 1 – enable

**PDE** enables the Pedometer (step-counter) engine. Note that to change the value of this bit, the PC1 bit must first be set to “0”.

PDE = 0 – disabled  
 PDE = 1 – enable

**TPE** enables the Tilt engine. Note that to change the value of this bit, the PC1 bit must first be set to “0”.

TPE = 0 – disable  
 TPE = 1 – enable

## CNTL2

Control register 2. Read/write control register that primarily controls tilt position state enabling. If a tilt direction bit’s state is set to one (1), a transition into the corresponding orientation state will generate an interrupt. If it is set to zero (0), a transition into the corresponding orientation state will not generate an interrupt. Note that to properly change the value of this register, the PC1 bit in CNTL1 must first be set to “0”.

R/W	R/W	R/W	R/W	R/W	R/W	R/W	R/W	Reset Value
SRST	COTC	LEM	RIM	DOM	UPM	FDM	FUM	00111111
Bit7	Bit6	Bit5	Bit4	Bit3	Bit2	Bit1	Bit0	
Address: 0x1B								

**SRST** initiates software reset, which performs the RAM reboot routine. This bit will remain 1 until the RAM reboot routine is finished.

SRST = 0 – no action  
 SRST = 1 – start POR / RAM reboot routine

Note for I<sup>2</sup>C Communication: Setting SRST = 1 will NOT result in an ACK, since the part immediately enters the RAM reboot routine. NACK may be used to confirm this command.

**COTC** Command test control.

COTC = 0 – no action  
 COTC = 1 – sets AA to COTR register, when the COTR register is read, COTC is cleared and STR = 55.

**LEM, RIM, DOM, UPM, FDM, FUM** these bits control the tilt axis mask. Per Table 17, if a direction’s bit is set to one (1), tilt in that direction will generate an interrupt. If it is set to zero (0), tilt in that direction will not generate an interrupt.



# ± 2g / 4g / 8g Tri-axis Digital Accelerometer Specifications

**PART NUMBER:**  
**KX126-1063**  
**Rev. 1.0**  
**22-Jun-17**

Bit	Description
LEM	<i>Left state enable (X-)</i>
RIM	<i>Right state enable (X+)</i>
DOM	<i>Down state enable (Y-)</i>
UPM	<i>Up state enable (Y+)</i>
FDM	<i>Face-Down state enable (Z-)</i>
FUM	<i>Face-Up state enable (Z+)</i>

**Table 17:** Tilt Direction™ Axis Mask

## CNTL3

Control register 3. Read/write control register that provides more feature set control. Note that to properly change the value of this register, the PC1 bit in CNTL1 must first be set to “0”.

R/W	R/W	R/W	R/W	R/W	R/W	R/W	R/W	Reset Value
OTP1	OTP0	OTDT2	OTDT1	OTDT0	OWUF2	OWUF1	OWUF0	10011000
Bit7	Bit6	Bit5	Bit4	Bit3	Bit2	Bit1	Bit0	
Address: 0x1C								

**OTP1, OTP0** sets the output data rate for the Tilt Position function per Table 18. The default Tilt Position ODR is 12.5Hz.

OTP1	OTP0	Output Data Rate
0	0	1.563Hz
0	1	6.25Hz
1	0	12.5Hz
1	1	50Hz

**Table 18:** Tilt Position Function Output Data Rate

	<b>± 2g / 4g / 8g Tri-axis Digital Accelerometer Specifications</b>	<b>PART NUMBER:</b> <b>KX126-1063</b> <b>Rev. 1.0</b> <b>22-Jun-17</b>
---	---	---

**OTDT2, OTDT1, OTDT0** sets the output data rate for the Directional Tap™ function per Table 19. The default Directional Tap™ ODR is 400Hz.

OTDT2	OTDT1	OTDT0	Output Data Rate
0	0	0	50Hz
0	0	1	100Hz
0	1	0	200Hz
0	1	1	400Hz
1	0	0	12.5Hz
1	0	1	25Hz
1	1	0	800Hz
1	1	1	1600Hz

**Table 19:** Directional Tap™ Function Output Data Rate

**OWUF2, OWUF1, OWUF0** sets the output data rate (per Table 20) at which the wake up (motion detection) performs its function. The default Motion Wake Up ODR is 50Hz.

Note: OWUF<2:0> setting needs to be <= OSA<3:0> to avoid irregular resulting acceleration ODR's

OWUF2	OWUF1	OWUF0	Output Data Rate
0	0	0	0.781Hz
0	0	1	1.563Hz
0	1	0	3.125Hz
0	1	1	6.250Hz
1	0	0	12.5Hz
1	0	1	25Hz
1	1	0	50Hz
1	1	1	100Hz

**Table 20:** Motion Wake Up Function Output Data Rate

### CNTL4

Control register 4. Read/write control register that provides more feature set control. Note that to properly change the value of this register, the PC1 bit in CNTL1 must first be set to “0”.

R/W	R/W	R/W	R/W	R/W	R/W	R/W	R/W	Reset Value
C_MODE	TH_MODE	WUFE	BTSE	HPE	OBTS2	OBTS1	OBTS0	01000000
Bit7	Bit6	Bit5	Bit4	Bit3	Bit2	Bit1	Bit0	
Address: 0x1D								



# ± 2g / 4g / 8g Tri-axis Digital Accelerometer Specifications

**PART NUMBER:**  
**KX126-1063**  
**Rev. 1.0**  
**22-Jun-17**

**C\_MODE** defines debounce counter operation

C\_MODE = 0 – debounce counter is in clear mode

C\_MODE = 1 – debounce counter is in decrement mode

**TH\_MODE** defines wake / back-to-sleep threshold mode

TH\_MODE = 0 – absolute threshold

TH\_MODE = 1 – relative threshold

**WUFE** enables the Wake up engine

WUFE = 0 – disabled

WUFE = 1 – enable

**BTSE** enables the Back to sleep engine

BTSE = 0 – disabled

BTSE = 1 – enable

**HPE** enables the High-pass outputs XHP, YHP, ZHP

HPE = 0 – high-pass outputs disabled

HPE = 1 – high-pass outputs enabled

**OBTS2, OBTS1, OBTS0** sets the output data rate (per Table 22) at which the back-to-sleep (motion detection) performs its function during wake state. The default Motion Wake Up ODR is 0.781Hz

Note: OBTS<2:0> setting needs to be <= OSA<3:0> to avoid irregular resulting acceleration ODR's

OBTS2	OBTS1	OBTS0	Output Data Rate
0	0	0	0.781Hz
0	0	1	1.563Hz
0	1	0	3.125Hz
0	1	1	6.250Hz
1	0	0	12.5Hz
1	0	1	25Hz
1	1	0	50Hz
1	1	1	100Hz

**Table 22:** Motion Back-to-Sleep Function Output Data Rate

	<b>± 2g / 4g / 8g Tri-axis Digital Accelerometer Specifications</b>	<b>PART NUMBER:</b> <b>KX126-1063</b> <b>Rev. 1.0</b> <b>22-Jun-17</b>
---	---	---

### CNTL5

Control register 5. Read/write control register that provides more feature set control. Note that to properly change the value of this register, the PC1 bit in CNTL1 must first be set to “0”.

R/W	R/W	R/W	R/W	R/W	R/W	R/W	R/W	
0	0	0	0	0	0	MAN_WAKE	MAN_SLEEP	Reset Value
Bit7	Bit6	Bit5	Bit4	Bit3	Bit2	Bit1	Bit0	00000001
Address: 0x1E								

**MAN\_WAKE** manual wake-sleep engine overwrite

*MAN\_WAKE = 0 – default*

*MAN\_WAKE = 1 – forces wake state (bit is self-cleared)*

**MAN\_SLEEP** manual wake-sleep engine overwrite

*MAN\_SLEEP = 0 – default*

*MAN\_SLEEP = 1 – forces sleep state (bit is self-cleared)*

**Notes:**

1. For having both WUF & BTS engine which has a wake state, if there is a wake interrupt, no additional wake interrupt is received until part is put back to sleep manually (using man\_sleep bit) or using the BTS interrupt.
2. Wake is the default state at power-up, shown in STAT register. For wake engine only operation, set MAN\_SLEEP bit to 1 in CNTL5 register in order to put KX126 in sleep state for the first time.

### ODCNTL

Output data control register that configures the acceleration outputs. Note that to properly change the value of this register, the PC1 bit in CNTL1 must first be set to “0”.

R/W	R/W	R/W	R/W	R/W	R/W	R/W	R/W	
IIR_BYPASS	LPRO	0	0	OSA3	OSA2	OSA1	OSA0	Reset Value
Bit7	Bit6	Bit5	Bit4	Bit3	Bit2	Bit1	Bit0	00000010
								Address: 0x1F

**IIR\_BYPASS** filter bypass mode

*IIR\_BYPASS = 0 – filtering applied*

*IIR\_BYPASS = 1 – filter bypassed*

**LPRO** low-pass filter roll off control

*LPRO = 0 – filter corner frequency set to ODR/9*

*LPRO = 1 – filter corner frequency set to ODR/2*

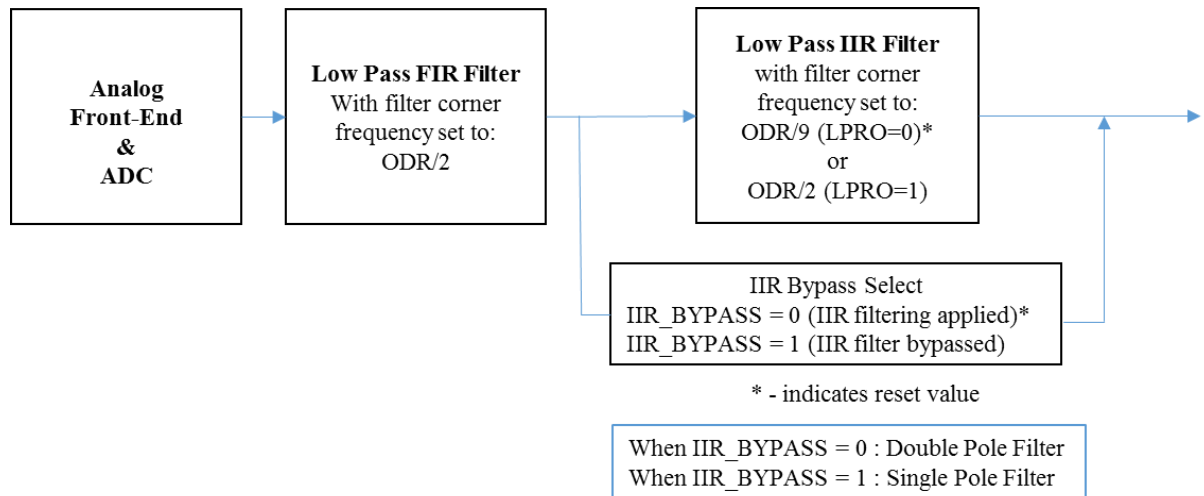

**Figure 9: Low Pass Filter Design and Control Circuitry**



## ± 2g / 4g / 8g Tri-axis Digital Accelerometer Specifications

**PART NUMBER:**  
**KX126-1063**  
 Rev. 1.0  
 22-Jun-17

*OSA3, OSA2, OSA1, OSA0 acceleration output data rate. The default ODR is 50Hz.*

OSA3	OSA2	OSA1	OSA0	Output Data Rate
0	0	0	0	12.5Hz*
0	0	0	1	25Hz*
0	0	1	0	50Hz*
0	0	1	1	100Hz*
0	1	0	0	200Hz*
0	1	0	1	400Hz**
0	1	1	0	800Hz
0	1	1	1	1600Hz
1	0	0	0	0.781Hz*
1	0	0	1	1.563Hz*
1	0	1	0	3.125Hz*
1	0	1	1	6.25Hz*
1	1	0	0	3200Hz**
1	1	0	1	6400Hz**
1	1	1	0	12800Hz**
1	1	1	1	25600Hz**

**Table 23:** Accelerometer Output Data Rates (ODR)

\* Low power mode available, all other data rates will default to High Resolution mode

\*\* 400Hz high resolution mode only (will not output in low power mode)

	<b>± 2g / 4g / 8g Tri-axis Digital Accelerometer Specifications</b>	<b>PART NUMBER:</b> <b>KX126-1063</b> <b>Rev. 1.0</b> <b>22-Jun-17</b>
---	---	---

## INC1

Interrupt Control 1. This register controls the settings for the physical interrupt pin INT1. Note that to properly change the value of this register, the PC1 bit in CNTL1 must first be set to “0”.

R/W	R/W	R/W	R/W	R/W	R/W	R/W	R/W	
PW11	PW10	IEN1	IEA1	IEL1	Reserved	STPOL	SPI3E	Reset Value
Bit7	Bit6	Bit5	Bit4	Bit3	Bit2	Bit1	Bit0	00010000
Address: 0x20								

**PW1<1:0>** – Pulse interrupt 1 width configuration

00 = 50µsec (10 µsec if OSA > 1600Hz)

01 = 1 \* OSA period

10 = 2 \* OSA periods

11 = 4 \* OSA periods

When PW1 > 0, Interrupt source auto-clearing (ACLR1=1) should be set to keep consistency between the internal status and the physical interrupt.

**IEN1** enables/disables the physical interrupt pin

IEN1 = 0 – physical interrupt pin is disabled

IEN1 = 1 – physical interrupt pin is enabled

**IEA1** Interrupt active level control for interrupt pin

IEA1 = 0 – active low

IEA1 = 1 – active high

**IEL1** Interrupt latch control for physical interrupt pin

IEL1 = 0 – latched until cleared by reading INT\_REL

IEL1 = 1 – pulsed. The pulse width is configurable by PW1.

**STPOL** sets the polarity of Self Test. This bit is ignored when STNULL is set.

STPOL = 0 – Negative

STPOL = 1 – Positive

**SPI3E** sets the 3-wire SPI interface

SPI3E = 0 – disabled

SPI3E = 1 – enabled



	<b>± 2g / 4g / 8g Tri-axis Digital Accelerometer Specifications</b>	<b>PART NUMBER:</b> <b>KX126-1063</b> <b>Rev. 1.0</b> <b>22-Jun-17</b>
---	---	---

### INC2

Interrupt Control 2. This register controls which axis and direction of detected motion can cause an interrupt. Note that to properly change the value of this register, the PC1 bit in CNTL1 must first be set to “0”.

R/W	R/W	R/W	R/W	R/W	R/W	R/W	R/W	
0	AOI	XNWUE	XPWUE	YNWUE	YPWUE	ZNWUE	ZPWUE	Reset Value
Bit7	Bit6	Bit5	Bit4	Bit3	Bit2	Bit1	Bit0	00111111
Address: 0x21								

**AOI** – AND-OR configuration on motion detection

0 – OR combination between selected directions

1 – AND combination between selected axes

Ex. If all directions are enabled,

Active state in OR configuration = (XN || XP || YN || YP || ZN || ZP)

Active state in AND configuration = (XN || XP) && (YN || YP) && (ZN || ZP)

**XNWUE** – x negative (x-): 0 = disabled, 1 = enabled

**XPWUE** – x positive (x+): 0 = disabled, 1 = enabled

**YNWUE** – y negative (y-): 0 = disabled, 1 = enabled

**YPWUE** – y positive (y+): 0 = disabled, 1 = enabled

**ZNWUE** – z negative (z-): 0 = disabled, 1 = enabled

**ZPWUE** – z positive (z+): 0 = disabled, 1 = enabled

### INC3

Interrupt Control 3. This register controls which axis and direction of tap/double tap can cause an interrupt. If a direction’s bit is set to one (1), a single or double tap in that direction will generate an interrupt. If it is set to zero (0), a single or double tap in that direction will not generate an interrupt. Note that to properly change the value of this register, the PC1 bit in CNTL1 must first be set to “0”.

R/W	R/W	R/W	R/W	R/W	R/W	R/W	R/W	
0	TMEN	TLEM	TRIM	TDOM	TUPM	TFDM	TFUM	Reset Value
Bit7	Bit6	Bit5	Bit4	Bit3	Bit2	Bit1	Bit0	00111111
Address: 0x22								

**TMEN** – enables/disables alternate tap masking scheme

TMEN = 0 – alternate tap masking scheme disabled

TMEN = 1 – alternate tap masking scheme enabled

**TLEM** – Tilt left state mask: 0 = disabled, 1 = enabled

**TRIM** – Tilt right state mask: 0 = disabled, 1 = enabled

**TDOM** – Tilt down state mask: 0 = disabled, 1 = enabled

**TUPM** – Tilt up state mask: 0 = disabled, 1 = enabled

**TFDM** – Tilt face-down state mask: 0 = disabled, 1 = enabled

**TFUM** – Tilt face-up state mask: 0 = disabled, 1 = enabled

	<b>± 2g / 4g / 8g Tri-axis Digital Accelerometer Specifications</b>	<b>PART NUMBER:</b> <b>KX126-1063</b> <b>Rev. 1.0</b> <b>22-Jun-17</b>
---	---	---

### INC4

Interrupt Control 4. This register controls routing of an interrupt reporting to physical interrupt pin INT1. Note that to properly change the value of this register, the PC1 bit in CNTL1 must first be set to “0”.

R/W	R/W	R/W	R/W	R/W	R/W	R/W	R/W	
FFI1	BFI1	WMI1	DRDY11	BTSI1	TDTI1	WUF11	TPI1	Reset Value
Bit7	Bit6	Bit5	Bit4	Bit3	Bit2	Bit1	Bit0	00000000
Address: 0x23								

**FFI1** – Free fall interrupt reported on physical interrupt pin INT1

FFI1 = 0 – disable

FFI1 = 1 – enable

**BFI1** – Buffer full interrupt reported on physical interrupt pin INT1

BFI1 = 0 – disable

BFI1 = 1 – enable

**WMI1** - Watermark interrupt reported on physical interrupt pin INT1

WMI1 = 0 – disable

WMI1 = 1 – enable

*Note: WMI & BFI1 are level triggered interrupt source. If the valid condition persists, and the interrupt stays enabled, the interrupt will block any further interrupts from other sources from triggering the INT1 pin. In order to let other interrupt sources through, WMI/BFI1 needs to be cleared once detected.*

**DRDY11** – Data ready interrupt reported on physical interrupt pin INT1

DRDY11 = 0 – disable

DRDY11 = 1 – enable

**BTSI1** – Back to sleep interrupt reported on physical interrupt pin INT1

BTSI1 = 0 – disable

BTSI1 = 1 – enable

**TDTI1** - Tap/Double Tap interrupt reported on physical interrupt pin INT1

TDTI1 = 0 – disable

TDTI1 = 1 – enable

**WUF11** – Wake-Up (motion detect) interrupt reported on physical interrupt pin INT1

WUF11 = 0 – disable

WUF11 = 1 – enable

**TPI1** – Tilt position interrupt reported on physical interrupt pin INT1

TPI1 = 0 – disable

TPI1 = 1 – enable

	<b>± 2g / 4g / 8g Tri-axis Digital Accelerometer Specifications</b>	<b>PART NUMBER:</b> <b>KX126-1063</b> <b>Rev. 1.0</b> <b>22-Jun-17</b>
---	---	---

## INC5

Interrupt Control 5. This register controls the settings for the physical interrupt pin INT2. Note that to properly change the value of this register, the PC1 bit in CNTL1 must first be set to “0”.

R/W	R/W	R/W	R/W	R/W	R/W	R/W	R/W	
PW21	PW20	IEN2	IEA2	IEL2	0	ACLR2	ACLR1	Reset Value
Bit7	Bit6	Bit5	Bit4	Bit3	Bit2	Bit1	Bit0	00010000
Address: 0x24								

**PW2<1:0>** – Pulse interrupt 2 width configuration

00 = 50µsec (10 µsec if OSA > 1600Hz)

01 = 1 \* OSA period

10 = 2 \* OSA periods

11 = 4 \* OSA periods

When PW2 > 0, Interrupt source auto-clearing (ACLR2=1) is strongly recommended to keep consistency between the internal status and the physical interrupt.

**IEN2** enables/disables the physical interrupt pin

IEN2 = 0 – physical interrupt pin is disabled

IEN2 = 1 – physical interrupt pin is enabled

**IEA2** Interrupt active level control for interrupt pin

IEA2 = 0 – active low

IEA2 = 1 – active high

**IEL2** Interrupt latch control for interrupt pin

IEL2 = 0 – latched

IEL2 = 1 – pulsed. The pulse width is configurable by PW2.

**ACLR2** – Latched interrupt source information(INS1-INS3) is cleared and physical interrupt-1 latched pin is changed to its inactive state at pulse interrupt-2 trailing edge. Note: WMI, BFI, and STPWMI are not auto-cleared by a pulse interrupt trailing edge.

ACLR2 = 0 – disable

ACLR2 = 1 – enable

**ACLR1** – Latched interrupt source information(INS1-INS3) is cleared and physical interrupt-2 latched pin is changed to its inactive state at pulse interrupt-1 trailing edge. Note: WMI, BFI, and STPWMI are not auto-cleared by a pulse interrupt trailing edge.

ACLR1 = 0 – disable

ACLR1 = 1 – enable

	<b>± 2g / 4g / 8g Tri-axis Digital Accelerometer Specifications</b>	<b>PART NUMBER:</b> <b>KX126-1063</b> <b>Rev. 1.0</b> <b>22-Jun-17</b>
---	---	---

### INC6

Interrupt Control 6. This register controls routing of interrupt reporting to physical interrupt pin INT2. Note that to properly change the value of this register, the PC1 bit in CNTL1 must first be set to “0”.

R/W	R/W	R/W	R/W	R/W	R/W	R/W	R/W	
FFI2	BFI2	WMI2	DRDYI2	BTSI2	TDTI2	WUFI2	TPI2	Reset Value
Bit7	Bit6	Bit5	Bit4	Bit3	Bit2	Bit1	Bit0	00000000
Address: 0x25								

**FFI2** – Free fall interrupt reported on physical interrupt pin INT2

FFI2 = 0 – disable

FFI2 = 1 – enable

**BFI2** – Buffer full interrupt reported on physical interrupt pin INT2

BF2 = 0 – disable

BF2 = 1 – enable

**WMI2** - Watermark interrupt reported on physical interrupt pin INT2

WMI2 = 0 – disable

WMI2 = 1 – enable

*Note: WMI is a level triggered interrupt source. If the valid condition persists, and the interrupt stays enabled, the interrupt will block any further interrupts from other sources from triggering the INT2 pin. In order to let other interrupt sources through, WMI needs to be cleared once detected.*

**DRDYI2** – Data ready interrupt reported on physical interrupt pin INT2

DRDYI2 = 0 – disable

DRDYI2 = 1 – enable

**BTSI2** – Back to sleep interrupt reported on physical interrupt pin INT2

BTSI2 = 0 – disable

BTSI2 = 1 – enable

**TDTI2** - Tap/Double Tap interrupt reported on physical interrupt pin INT2

TDTI2 = 0 – disable

TDTI2 = 1 – enable

**WUFI2** – Wake-Up (motion detect) interrupt reported on physical interrupt pin INT2

WUFI2 = 0 – disable

WUFI2 = 1 – enable

**TPI2** – Tilt position interrupt reported on physical interrupt pin INT2

TPI2 = 0 – disable

TPI2 = 1 – enable

	<b>± 2g / 4g / 8g Tri-axis Digital Accelerometer Specifications</b>	<b>PART NUMBER:</b> <b>KX126-1063</b> <b>Rev. 1.0</b> <b>22-Jun-17</b>
---	---	---

### INC7

Interrupt Control 7 – Pedometer (step counter) Interrupt control. Note that to properly change the value of this register, the PC1 bit in CNTL1 must first be set to “0”.

R/W	R/W	R/W	R/W	R/W	R/W	R/W	R/W	
0	STPOVI2	STPWMI2	STPINCI2	0	STPOVI1	STPWMI1	STPINCI1	Reset Value
Bit7	Bit6	Bit5	Bit4	Bit3	Bit2	Bit1	Bit0	00000000
Address: 0x26								

Please note, that the STPWMI is a level triggered interrupt source (same as buffer's WMI). Any mechanism to clear the INS register bits will fail as long as the condition persists. If the condition persists and the STPWMI interrupt stays enabled, the level triggered interrupt will block any further interrupts from other sources from triggering the pin. In order to let other interrupt sources through, STPWMI needs to be set low once detected. STPINCI and STPOVI are momentary events that do not persist.

**STPOVI2** – Step counter overflow interrupt reported on physical interrupt pin INT2

STPOVI2 = 0 – disable

STPOVI2 = 1 – enable

**STPWMI2** – Step counter watermark interrupt reported on physical interrupt pin INT2

STPWMI2 = 0 – disable

STPWMI2 = 1 – enable

**STPINCI2** – Step counter increment interrupt reported on physical interrupt pin INT2

STPINCI2 = 0 – disable

STPINCI2 = 1 – enable

**STPOVI1** – Step counter overflow interrupt reported on physical interrupt pin INT1

STPOVI1 = 0 – disable

STPOVI1 = 1 – enable

**STPWMI1** – Step counter watermark interrupt reported on physical interrupt pin INT1

STPWMI1 = 0 – disable

STPWMI1 = 1 – enable

**STPINCI1** – Step counter increment interrupt reported on physical interrupt pin INT1

STPINCI1 = 0 – disable

STPINCI1 = 1 – enable

	<b>± 2g / 4g / 8g Tri-axis Digital Accelerometer Specifications</b>	<b>PART NUMBER:</b> <b>KX126-1063</b> <b>Rev. 1.0</b> <b>22-Jun-17</b>
---	---	---

### TILT\_TIMER

This register is the initial count register for the tilt position state timer (0 to 255 counts). Every count is calculated as 1/ODR delay period, where the ODR is user-defined per Table 18. A new state must be valid as many measurement periods before the change is accepted. Note that to properly change the value of this register, the PC1 bit in CNTL1 must first be set to “0”.

R/W	R/W	R/W	R/W	R/W	R/W	R/W	R/W	
TSC7	TSC6	TSC5	TSC4	TSC3	TSC2	TSC1	TSC0	Reset Value
Bit7	Bit6	Bit5	Bit4	Bit3	Bit2	Bit1	Bit0	00000000
Address: 0x27								

### TDTRC

Tap/Double Tap Report Control. Note that to properly change the value of this register, the PC1 bit in CNTL1 must first be set to “0”.

R/W	R/W	R/W	R/W	R/W	R/W	R/W	R/W	
0	0	0	0	0	0	DTRE	STRE	Reset Value
Bit7	Bit6	Bit5	Bit4	Bit3	Bit2	Bit1	Bit0	00000011
Address: 0x28								

**DTRE** – enables/disables the double tap interrupt

*DTRE = 0 – do not update INS1 or DTDS if double tap occurs*

*DTRE = 1 – update INS1 and DTDS in INS2 with double tap events*

**STRE** – enables/disables single tap interrupt

*STRE = 0 – do not update INS1 or DTDS if single tap occurs.*

*STRE = 1 – update INS1 and DTDS in INS2 single tap events*

	<b>± 2g / 4g / 8g Tri-axis Digital Accelerometer Specifications</b>	<b>PART NUMBER:</b> <b>KX126-1063</b> <b>Rev. 1.0</b> <b>22-Jun-17</b>
---	---	---

### TDTC

This register contains counter information for the detection of a double tap event. When the Directional TapTM ODR is 400Hz or less, every count is calculated as 1/ODR delay period. When the Directional TapTM ODR is 800Hz, every count is calculated as 2/ODR delay period. When the Directional TapTM ODR is 1600Hz, every count is calculated as 4/ODR delay period. The Directional TapTM ODR is user-defined per Table 19. The TDTC counts starts at the beginning of the first tap and it represents the minimum time separation between the first tap and the second tap in a double tap event. More specifically, the second tap event must end outside of the TDTC. The Kionix recommended default value is 0.3 seconds (0x78). Note that to properly change the value of this register, the PC1 bit in CNTL1 must first be set to “0”.

R/W	R/W	R/W	R/W	R/W	R/W	R/W	R/W	
TDTC7	TDTC6	TDTC5	TDTC4	TDTC3	TDTC2	TDTC1	TDTC0	Reset Value
Bit7	Bit6	Bit5	Bit4	Bit3	Bit2	Bit1	Bit0	01111000
Address: 0x29								

### TTH

This register represents the 8-bit jerk high threshold to determine if a tap is detected. Though this is an 8-bit register, the register value is internally multiplied by two in order to set the high threshold. This multiplication results in a range of 0d to 510d with a resolution of two counts. The Performance Index (PI) is the jerk signal that is expected to be less than this threshold, but greater than the TTL threshold during single and double tap events. Note that to properly change the value of this register, the PC1 bit in CNTL1 must first be set to “0”. The Kionix recommended default value is 203 (0xCB) and the Performance Index is calculated as:

$$\begin{aligned}
 X' &= X(\text{current}) - X(\text{previous}) \\
 Y' &= Y(\text{current}) - Y(\text{previous}) \\
 Z' &= Z(\text{current}) - Z(\text{previous})
 \end{aligned}$$

$$PI = |X'| + |Y'| + |Z'|$$

**Equation 1: Performance Index**

R/W	R/W	R/W	R/W	R/W	R/W	R/W	R/W	
TTH7	TTH6	TTH5	TTH4	TTH3	TTH2	TTH1	TTH0	Reset Value
Bit7	Bit6	Bit5	Bit4	Bit3	Bit2	Bit1	Bit0	11001011
Address: 0x2A								

	<b>± 2g / 4g / 8g Tri-axis Digital Accelerometer Specifications</b>	<b>PART NUMBER:</b> <b>KX126-1063</b> <b>Rev. 1.0</b> <b>22-Jun-17</b>
---	---	---

### TTL

This register represents the 8-bit (0d– 255d) jerk low threshold to determine if a tap is detected. The Performance Index (PI) is the jerk signal that is expected to be greater than this threshold and less than the TTH threshold during single and double tap events. The Kionix recommended default value is 26 (0x1A). Note that to properly change the value of this register, the PC1 bit in CNTL1 must first be set to “0”.

R/W	R/W	R/W	R/W	R/W	R/W	R/W	R/W	
TTL7	TTL6	TTL5	TTL4	TTL3	TTL2	TTL1	TTL0	Reset Value
Bit7	Bit6	Bit5	Bit4	Bit3	Bit2	Bit1	Bit0	00011010
Address: 0x2B								

### FTD

This register contains counter information for the detection of any tap event. When the Directional Tap<sup>TM</sup> ODR is 400Hz or less, every count is calculated as 1/ODR delay period. When the Directional Tap<sup>TM</sup> ODR is 800Hz, every count is calculated as 2/ODR delay period. When the Directional Tap<sup>TM</sup> ODR is 1600Hz, every count is calculated as 4/ODR delay period. The Directional Tap<sup>TM</sup> ODR is user-defined per Table 19. In order to ensure that only tap events are detected, these time limits are used. A tap event must be above the performance index threshold for at least the low limit (FTDL0 – FTDL2) and no more than the high limit (FTDH0 – FTDH4). The Kionix recommended default value for the high limit is 0.05 seconds and for the low limit is 0.005 seconds (0xA2). Note that to properly change the value of this register, the PC1 bit in CNTL1 must first be set to “0”.

R/W	R/W	R/W	R/W	R/W	R/W	R/W	R/W	
FTDH4	FTDH3	FTDH2	FTDH1	FTDH0	FTDL2	FTDL1	FTDL0	Reset Value
Bit7	Bit6	Bit5	Bit4	Bit3	Bit2	Bit1	Bit0	10100010
Address: 0x2C								



	<b>± 2g / 4g / 8g Tri-axis Digital Accelerometer Specifications</b>	<b>PART NUMBER:</b> <b>KX126-1063</b> <b>Rev. 1.0</b> <b>22-Jun-17</b>
---	---	---

## STD

This register contains counter information for the detection of a double tap event. When the Directional Tap™ ODR is 400Hz or less, every count is calculated as 1/ODR delay period. When the Directional Tap™ ODR is 800Hz, every count is calculated as 2/ODR delay period. When the Directional Tap™ ODR is 1600Hz, every count is calculated as 4/ODR delay period. The Directional Tap™ ODR is user-defined per Table 19. In order to ensure that only tap events are detected, this time limit is used. This register sets the total amount of time that the two taps in a double tap event can be above the PI threshold (TTL). The Kionix recommended default value for STD is 0.09 seconds (0x24). Note that to properly change the value of this register, the PC1 bit in CNTL1 must first be set to “0”.

R/W	R/W	R/W	R/W	R/W	R/W	R/W	R/W	
STD7	STD6	STD5	STD4	STD3	STD2	STD1	STD0	Reset Value
Bit7	Bit6	Bit5	Bit4	Bit3	Bit2	Bit1	Bit0	00100100
Address: 0x2D								

## TLT

This register contains counter information for the detection of a tap event. When the Directional Tap™ ODR is 400Hz or less, every count is calculated as 1/ODR delay period. When the Directional Tap™ ODR is 800Hz, every count is calculated as 2/ODR delay period. When the Directional Tap™ ODR is 1600Hz, every count is calculated as 4/ODR delay period. The Directional Tap™ ODR is user-defined per Table 19. In order to ensure that only tap events are detected, this time limit is used. This register sets the total amount of time that the tap algorithm will count samples that are above the PI threshold (TTL) during a potential tap event. It is used during both single and double tap events. However, reporting of single taps on the physical interrupt pin INT1 or INT2 will occur at the end of the TWS. The Kionix recommended default value for TLT (TDT Latency Timer) is 0.1 seconds (0x28). Note that to properly change the value of this register, the PC1 bit in CNTL1 must first be set to “0”.

R/W	R/W	R/W	R/W	R/W	R/W	R/W	R/W	
TLT7	TLT6	TLT5	TLT4	TLT3	TLT2	TLT1	TLT0	Reset Value
Bit7	Bit6	Bit5	Bit4	Bit3	Bit2	Bit1	Bit0	00101000
Address: 0x2E								



# ± 2g / 4g / 8g Tri-axis Digital Accelerometer Specifications

**PART NUMBER:**  
**KX126-1063**  
**Rev. 1.0**  
**22-Jun-17**

## TWS

This register contains counter information for the detection of single and double taps. When the Directional Tap™ ODR is 400Hz or less, every count is calculated as 1/ODR delay period. When the Directional Tap™ ODR is 800Hz, every count is calculated as 2/ODR delay period. When the Directional Tap™ ODR is 1600Hz, every count is calculated as 4/ODR delay period. The Directional Tap™ ODR is user-defined per Table 19. It defines the time window for the entire tap event, single or double, to occur. Reporting of single taps on the physical interrupt pin INT1 or INT2 will occur at the end of this tap window. The Kionix recommended default value for TWS is 0.4 seconds (0xA0). Note that to properly change the value of this register, the PC1 bit in CNTL1 must first be set to “0”.

R/W	R/W	R/W	R/W	R/W	R/W	R/W	R/W	
TWS7	TWS6	TWS5	TWS4	TWS3	TWS2	TWS1	TWS0	Reset Value
Bit7	Bit6	Bit5	Bit4	Bit3	Bit2	Bit1	Bit0	10100000
Address: 0x2F								

## FFTH

Free Fall Threshold. This register contains the threshold of the Free fall detection. This value is compared to the top 8 bits of the accelerometer 8g output (regardless of GSEL<1:0> setting in CNTL1 register). Note that to properly change the value of this register, the PC1 bit in CNTL1 must first be set to “0”.

R/W	R/W	R/W	R/W	R/W	R/W	R/W	R/W	
FFTH7	FFTH6	FFTH5	FFTH4	FFTH3	FFTH2	FFTH1	FFTH0	Reset Value
Bit7	Bit6	Bit5	Bit4	Bit3	Bit2	Bit1	Bit0	00000000
Address: 0x30								

## FFC

Free Fall Counter. This register contains the counter setting of the Free fall detection. Every count is calculated as 1/ODR delay period where ODR is set bit OFF1<2:0> in FFCNTL register. Note that to properly change the value of this register, the PC1 bit in CNTL1 must first be set to “0”.

R/W	R/W	R/W	R/W	R/W	R/W	R/W	R/W	
FFC7	FFC6	FFC5	FFC4	FFC3	FFC2	FFC1	FFC0	Reset Value
Bit7	Bit6	Bit5	Bit4	Bit3	Bit2	Bit1	Bit0	00000000
Address: 0x31								

## FFCNTL

Free Fall Control. This register contains the counter setting of the Free fall detection. Note that to properly change the value of this register, the PC1 bit in CNTL1 must first be set to “0”.

R/W	R/W	R/W	R/W	R/W	R/W	R/W	R/W	
FFIE	ULMODE	0	0	DCRM	OFF12	OFF11	OFF10	Reset Value
Bit7	Bit6	Bit5	Bit4	Bit3	Bit2	Bit1	Bit0	00000000
Address: 0x32								



# ± 2g / 4g / 8g Tri-axis Digital Accelerometer Specifications

**PART NUMBER:**  
**KX126-1063**  
 Rev. 1.0  
 22-Jun-17

**FFIE** – Free fall engine enable

FFIE = 0 – disable

FFIE = 1 – enable

**ULMODE** – Free fall interrupt latch/un-latch control

ULMODE = 0 – latched

ULMODE = 1 – unlatched

**DCRM** – Debounce methodology control

DCRM = 0 – count up/down

DCRM = 1 – count up/reset

**OFFI<2:0>**: – Output Data Rate at which the Free fall engine performs its function.

The default Free fall ODR is 12.5Hz.

OFFI	Output Data Rate (Hz)
000	12.5
001	25
010	50
011	100
100	200
101	400
110	800
111	1600

**Table 21:** Free Fall Function Output Data Rate

## TILT\_ANGLE\_LL

**Low Limit:** This register sets the low level threshold for tilt angle detection. The minimum suggested tilt angle is 10°. The KX126 ships from the factory with tilt angle set to a low threshold of 22° from horizontal. A different default tilt angle can be requested from the factory. Note that to properly change the value of this register, the PC1 bit in CNTL1 must first be set to “0”.

R/W	R/W	R/W	R/W	R/W	R/W	R/W	R/W	Reset Value
LL7	LL6	LL5	LL4	LL3	LL2	LL1	LL0	00001100
Bit7	Bit6	Bit5	Bit4	Bit3	Bit2	Bit1	Bit0	
Address: 0x34								

	<b>± 2g / 4g / 8g Tri-axis Digital Accelerometer Specifications</b>	<b>PART NUMBER:</b> <b>KX126-1063</b> <b>Rev. 1.0</b> <b>22-Jun-17</b>
---	---	---

**TILT\_ANGLE\_HL**

High Limit: This register sets the high level threshold for tilt angle detection. The minimum suggested tilt angle is 10°. Note that to properly change the value of this register, the PC1 bit in CNTL1 must first be set to “0”.

R/W	R/W	R/W	R/W	R/W	R/W	R/W	R/W	
HL7	HL6	HL5	HL4	HL3	HL2	HL1	HL0	Reset Value
Bit7	Bit6	Bit5	Bit4	Bit3	Bit2	Bit1	Bit0	00101010
Address: 0x35								

**HYST\_SET**

This register sets the Hysteresis that is placed in between the Screen Rotation states. The KX126 ships from the factory with HYST\_SET set to ±15° of hysteresis. A different default hysteresis can be requested from the factory. Note that to properly change the value of this register, the PC1 bit in CNTL1 must first be set to “0”.

R/W	R/W	R/W	R/W	R/W	R/W	R/W	R/W	
Reserved	Reserved	HYST5	HYST4	HYST3	HYST2	HYST1	HYST0	Reset Value
Bit7	Bit6	Bit5	Bit4	Bit3	Bit2	Bit1	Bit0	00010100
Address: 0x36								

*HYST5: Z\_gap control for tilt position.*  
*HYST<4:0>: X and Y gain control for tilt position.*

	<b>± 2g / 4g / 8g Tri-axis Digital Accelerometer Specifications</b>	<b>PART NUMBER:</b> <b>KX126-1063</b> <b>Rev. 1.0</b> <b>22-Jun-17</b>
---	---	---

**LP\_CNTL**

Low Power Control: The Averaging Filter Control setting can be used in the optimization of current and noise performance of the accelerometer and can be tested using [Kionix FlexSet™ Performance Optimization Tool](#). More specifically, this setting determines the number of internal acceleration samples to be averaged in Low Current mode. Also, it determines the number of internal acceleration samples to be averaged for digital engines operation (Directional Tap™, Tilt, Wake-Up, Back-to-Sleep, Free fall, Pedometer) both in *High Resolution* and *Low Current* modes. Note that to properly change the value of this register, the PC1 bit in CNTL1 must first be set to “0”.

R/W	R/W	R/W	R/W	R/W	R/W	R/W	R/W	
Reserved	AVC2	AVC1	AVC0	Reserved	Reserved	Reserved	Reserved	Reset Value
Bit7	Bit6	Bit5	Bit4	Bit3	Bit2	Bit1	Bit0	01001011
Address: 0x37								

- AVC<2:0>** – Averaging Filter Control, the default setting is 16 samples averaged
- 000 = No Averaging
  - 001 = 2 Samples Averaged
  - 010 = 4 Samples Averaged
  - 011 = 8 Samples Averaged
  - 100 = 16 Samples Averaged (default)
  - 101 = 32 Samples Averaged
  - 110 = 64 Samples Averaged
  - 111 = 128 Samples Averaged

*This value controls averaging count for low power mode accelerometer outputs and algorithm engine data inputs.*

**Reserved** – these bits are reserved and their value should not be changed.

	<b>± 2g / 4g / 8g Tri-axis Digital Accelerometer Specifications</b>	<b>PART NUMBER:</b> <b>KX126-1063</b> <b>Rev. 1.0</b> <b>22-Jun-17</b>
---	---	---

### WUFTH, BTSWUFTH and BTSTH

Wake-up/Back-to-sleep engine thresholds. Note that to properly change the value of this register, the PC1 bit in CNTL1 must first be set to “0”.

R/W	R/W	R/W	R/W	R/W	R/W	R/W	R/W	I <sup>2</sup> C Address	Register	Reset Value
WUFTH7	WUFTH6	WUFTH5	WUFTH4	WUFTH3	WUFTH2	WUFTH1	WUFTH0	0x3C	WUFTH	10000000
0	BTSTH10	BTSTH9	BTSTH8	0	WUFTH10	WUFTH9	WUFTH8	0x3D	BTSWUFTH	00000000
BTSTH7	BTSTH6	BTSTH5	BTSTH4	BTSTH3	BTSTH2	BTSTH1	BTSTH0	0x3E	BTSTH	10000000
Bit7	Bit6	Bit5	Bit4	Bit3	Bit2	Bit1	Bit0			

**WUFTH<10:0>**: Threshold for wake-up interrupt

**BTSTH<10:0>**: Threshold for back to sleep interrupt

The threshold values set by WUFTH<10:0> and BTSTH<10:0> are compared to the top 8 bits of the accelerometer 8g output (regardless of GSEL<1:0> setting in CNTL1 register). This results in threshold resolution of 3.9 mg/count per Equation 2.

$$2^{11} \text{ counts} / (+8g - (-8g)) = 2048 \text{ counts} / 16g = 3.9 \text{ mg/count}$$

**Equation 2:** Wake-Up / Back-to-Sleep Resolution Calculations

### BTSC

This register is the initial count register for the BTS motion detection timer (0 to 255 counts). Every count is calculated as 1/ODR delay period, where the Back to Sleep ODR is user-defined per Table 22. Note that to properly change the value of this register, the PC1 bit in CNTL1 must first be set to “0”.

R/W	R/W	R/W	R/W	R/W	R/W	R/W	R/W	Reset Value
BTSC7	BTSC6	BTSC5	BTSC4	BTSC3	BTSC2	BTSC1	BTSC0	00000000
Bit7	Bit6	Bit5	Bit4	Bit3	Bit2	Bit1	Bit0	
Address: 0x3F								

	<b>± 2g / 4g / 8g Tri-axis Digital Accelerometer Specifications</b>	<b>PART NUMBER:</b>
		<b>KX126-1063</b>
		<b>Rev. 1.0</b>
		<b>22-Jun-17</b>

### WUFC

This register is the initial count register for the WUF motion detection timer (0 to 255 counts). Every count is calculated as 1/ODR delay period, where the ODR is user-defined per Table 20. A new state must be valid as many measurement periods before the change is accepted. Note that to properly change the value of this register, the PC1 bit in CNTL1 must first be set to “0”.

R/W	R/W	R/W	R/W	R/W	R/W	R/W	R/W	
WUFC7	WUFC6	WUFC5	WUFC4	WUFC3	WUFC2	WUFC1	WUFC0	Reset Value
Bit7	Bit6	Bit5	Bit4	Bit3	Bit2	Bit1	Bit0	00000000
Address: 0x40								

### PED\_STPWM\_L and PED\_STPWM\_H

Pedometer Step Counter Watermark registers set the 16-bit count value used as a watermark threshold for step counting. When the threshold value is exceeded, the interrupt will be reflected the STPWMI bit in INS2 register and on physical interrupt pin if configured. Note that to properly change the value of these registers, the PC1 bit in CNTL1 must first be set to “0”.

PED\_STPWM\_L register holds the lower 8 bits of the count value.

R/W	R/W	R/W	R/W	R/W	R/W	R/W	R/W	
STPWM7	STPWM6	STPWM5	STPWM4	STPWM3	STPWM2	STPWM1	STPWM0	Reset Value
Bit7	Bit6	Bit5	Bit4	Bit3	Bit2	Bit1	Bit0	00000000
Address: 0x41								

PED\_STPWM\_H register holds the upper 8 bits of the count value.

R/W	R/W	R/W	R/W	R/W	R/W	R/W	R/W	
STPWM15	STPWM14	STPWM13	STPWM12	STPWM11	STPWM10	STPWM9	STPWM8	Reset Value
Bit7	Bit6	Bit5	Bit4	Bit3	Bit2	Bit1	Bit0	00000000
Address: 0x42								

### PED\_CNTL1

Pedometer Control register 1. Note that to properly change the value of this register, the PC1 bit in CNTL1 must first be set to “0”.

R/W	R/W	R/W	R/W	R/W	R/W	R/W	R/W	
0	STP_TH2	STP_TH1	STP_TH0	MAG_SCALE3	MAG_SCALE2	MAG_SCALE1	MAG_SCALE0	Reset Value
Bit7	Bit6	Bit5	Bit4	Bit3	Bit2	Bit1	Bit0	01000110
Address: 0x43								

**STP\_TH<2:0>** – It is used to allow a successful start for step detection. It is a threshold for discarding step counting if not enough steps are coming. The default value is 100b, which means actual 8 steps threshold.

	<b>± 2g / 4g / 8g Tri-axis Digital Accelerometer Specifications</b>	<b>PART NUMBER:</b> <b>KX126-1063</b> <b>Rev. 1.0</b> <b>22-Jun-17</b>
---	---	---

000 = No steps  
 001 = 2 steps  
 010 = 4 steps  
 011 = 6 steps  
 100 = 8 steps (default)  
 101 = 10 steps  
 110 = 12 steps  
 111 = 14 steps

**MAG\_SCALE<3:0>** – Scaling factor for the input signal (x, y, z). The default value is 6.

**PED\_CNTL2**

Pedometer Control register 2. Note that to properly change the value of this register, the PC1 bit in CNTL1 must first be set to “0”.

R/W	R/W	R/W	R/W	R/W	R/W	R/W	R/W	
0	HPS2	HPS1	HPS0	PED_ODR3	PED_ODR2	PED_ODR1	PED_ODR0	Reset Value
Bit7	Bit6	Bit5	Bit4	Bit3	Bit2	Bit1	Bit0	00111100
Address: 0x44								

**HPS<2:0>** – A Scaling factor for the output from the high-pass filter. The default value is 011b, which means a scaling factor of 8.

000 = 1  
 001 = 2  
 010 = 4  
 011 = 8 (default)  
 100 = 16  
 101 = 32  
 110 = 64  
 111 = 128

**PED\_ODR<3:0>** – Pedometer Engine ODR Select

1100 = 100Hz (default)  
 0110 = 50Hz



	<b>± 2g / 4g / 8g Tri-axis Digital Accelerometer Specifications</b>	<b>PART NUMBER:</b> <b>KX126-1063</b> <b>Rev. 1.0</b> <b>22-Jun-17</b>
---	---	---

### PED\_CNTL3

Pedometer Control register 3. Note that to properly change the value of this register, the PC1 bit in CNTL1 must first be set to “0”.

R/W	R/W	R/W	R/W	R/W	R/W	R/W	R/W	
0	0	FCB2	FCB1	FCB0	FCA2	FCA1	FCA0	Reset Value
Bit7	Bit6	Bit5	Bit4	Bit3	Bit2	Bit1	Bit0	00001110
Address: 0x45								

**FCB<2:0>** – Scaling factor internal high-pass filter. Values: 0, 1, ..., 7. The default value is 001b, which corresponds to 1.

**FCA<2:0>** – Scaling factor internal high-pass filter. The default value is 110b, which corresponds to 64.

- 000 = 1
- 001 = 2
- 010 = 4
- 011 = 8
- 100 = 16
- 101 = 32
- 110 = 64 (default)
- 111 = 128

### PED\_CNTL4

Pedometer Control register 4. Note that to properly change the value of this register, the PC1 bit in CNTL1 must first be set to “0”.

R/W	R/W	R/W	R/W	R/W	R/W	R/W	R/W	
0	B_CNT2	B_CNT1	B_CNT0	A_H3	A_H2	A_H1	A_H0	Reset Value
Bit7	Bit6	Bit5	Bit4	Bit3	Bit2	Bit1	Bit0	00011111
Address: 0x46								

**B\_CNT<2:0>** – Samples below the zero threshold before setting. Values: 0, 1, ..., 7. Default value is 001b which corresponds to 1.

**A\_H<3:0>** – Maximum area of the peak (maximum impact from the floor). Values: 0, 1, ..., 15. Default value is 1111b which corresponds to 15

	<b>± 2g / 4g / 8g Tri-axis Digital Accelerometer Specifications</b>	<b>PART NUMBER:</b> <b>KX126-1063</b> <b>Rev. 1.0</b> <b>22-Jun-17</b>
---	---	---

### PED\_CNTL5

Pedometer Control register 5. Note that to properly change the value of this register, the PC1 bit in CNTL1 must first be set to “0”.

R/W	R/W	R/W	R/W	R/W	R/W	R/W	R/W	
A_L7	A_L6	A_L5	A_L4	A_L3	A_L2	A_L1	A_L0	Reset Value
Bit7	Bit6	Bit5	Bit4	Bit3	Bit2	Bit1	Bit0	00111100
Address: 0x47								

**A\_L<7:0>** – Minimum area of the peak (minimum impact from the floor). Values: 0, 1, ..., 255. Default value is 0x3C (60d).

### PED\_CNTL6

Pedometer Control register 6. Note that to properly change the value of this register, the PC1 bit in CNTL1 must first be set to “0”.

R/W	R/W	R/W	R/W	R/W	R/W	R/W	R/W	
0	0	M_H5	M_H4	M_H3	M_H2	M_H1	M_H0	Reset Value
Bit7	Bit6	Bit5	Bit4	Bit3	Bit2	Bit1	Bit0	00010100
Address: 0x48								

**M\_H<5:0>** – Maximum time interval for the peak. Values: 0, 1, ..., 63. Default value is 0x14 (20d) or ~0.80 sec

### PED\_CNTL7

Pedometer Control register 7. Note that to properly change the value of this register, the PC1 bit in CNTL1 must first be set to “0”.

R/W	R/W	R/W	R/W	R/W	R/W	R/W	R/W	
M_L7	M_L6	M_L5	M_L4	M_L3	M_L2	M_L1	M_L0	Reset Value
Bit7	Bit6	Bit5	Bit4	Bit3	Bit2	Bit1	Bit0	00000110
Address: 0x49								

**M\_L<7:0>** – Minimum time interval for the peak. Values: 0, 1, ..., 255. Default value is 0x06 or 0.06sec

	<b>± 2g / 4g / 8g Tri-axis Digital Accelerometer Specifications</b>	<b>PART NUMBER:</b>
		<b>KX126-1063</b> <b>Rev. 1.0</b> <b>22-Jun-17</b>

### PED\_CNTL8

Pedometer Control register 8. Note that to properly change the value of this register, the PC1 bit in CNTL1 must first be set to “0”.

R/W	R/W	R/W	R/W	R/W	R/W	R/W	R/W	Reset Value
T_L7	T_L6	T_L5	T_L4	T_L3	T_L2	T_L1	T_L0	00000101
Bit7	Bit6	Bit5	Bit4	Bit3	Bit2	Bit1	Bit0	
Address: 0x4A								

**T\_L<7:0>** – Time window for noise and delay time. Values: 0, 1, ..., 255. Default value is 0x05 or ~0.05sec

### PED\_CNTL9

Pedometer Control register 9. Note that to properly change the value of this register, the PC1 bit in CNTL1 must first be set to “0”.

R/W	R/W	R/W	R/W	R/W	R/W	R/W	R/W	Reset Value
0	0	T_M5	T_M4	T_M3	T_M2	T_M1	T_M0	00010110
Bit7	Bit6	Bit5	Bit4	Bit3	Bit2	Bit1	Bit0	
Address: 0x4B								

**T\_M<5:0>** – Time interval to prevent overflowing. Values: 0, 1, ...,63. Default value is 0x16 or ~0.80sec

### PED\_CNTL10

Pedometer Control register 10. Note that to properly change the value of this register, the PC1 bit in CNTL1 must first be set to “0”.

R/W	R/W	R/W	R/W	R/W	R/W	R/W	R/W	Reset Value
0	0	T_P5	T_P4	T_P3	T_P2	T_P1	T_P0	00010011
Bit7	Bit6	Bit5	Bit4	Bit3	Bit2	Bit1	Bit0	
Address: 0x4C								

**T\_P<5:0>** – Minimum time interval for a single stride. Values: 0, 1, ...,63. Default value = 0x13 or ~0.18sec

	<b>± 2g / 4g / 8g Tri-axis Digital Accelerometer Specifications</b>	<b>PART NUMBER:</b> <b>KX126-1063</b> <b>Rev. 1.0</b> <b>22-Jun-17</b>
---	---	---

### SELF\_TEST

Self Test Enable register: When 0xCA is written to this register, the MEMS self-test function is enabled. Electrostatic-actuation of the accelerometer, results in a DC shift of the X, Y and Z axis outputs. Writing 0x00 to this register will return the accelerometer to normal operation.

*Note, this is a write-only register. Read back value from this register will always be 0x00.*

W	W	W	W	W	W	W	W	
1	1	0	0	1	0	1	0	Reset Value
Bit7	Bit6	Bit5	Bit4	Bit3	Bit2	Bit1	Bit0	00000000
Address: 0x4D								

### BUF\_CNTL1

Read/write control register that controls the buffer sample threshold. Note that to properly change the value of this register, the PC1 bit in CNTL1 must first be set to “0”.

R/W	R/W	R/W	R/W	R/W	R/W	R/W	R/W	
SMP_TH7	SMP_TH6	SMP_TH5	SMP_TH4	SMP_TH3	SMP_TH2	SMP_TH1	SMP_TH0	Reset Value
Bit7	Bit6	Bit5	Bit4	Bit3	Bit2	Bit1	Bit0	00000000
Address: 0x5A								

**SMP\_TH[9:0] Sample Threshold;** determines the number of samples that will trigger a watermark interrupt or will be saved prior to a trigger event. When BRES=1, the maximum number of samples is 342; when BRES=0, the maximum number of samples is 683. Note: SMP\_TH[9:8] are located in BUF\_CNTL2.

Buffer Model	Sample Function
Bypass	None
FIFO	Specifies how many buffer sample are needed to trigger a watermark interrupt.
Stream	Specifies how many buffer samples are needed to trigger a watermark interrupt.
Trigger	Specifies how many buffer samples before the trigger event are retained in the buffer.
FILO	Specifies how many buffer samples are needed to trigger a watermark interrupt.

**Table 22:** Sample Threshold Operation by Buffer Mode

	<b>± 2g / 4g / 8g Tri-axis Digital Accelerometer Specifications</b>	<b>PART NUMBER:</b> <b>KX126-1063</b> <b>Rev. 1.0</b> <b>22-Jun-17</b>
---	---	---

**BUF\_CNTL2**

Read/write control register that controls sample buffer operation. Note that to properly change the value of this register, the PC1 bit in CNTL1 must first be set to “0”.

R/W	R/W	R/W	R/W	R/W	R/W	R/W	R/W	
BUFE	BRES	BFIE	0	SMP_TH9	SMP_TH8	BM1	BM0	Reset Value
Bit7	Bit6	Bit5	Bit4	Bit3	Bit2	Bit1	Bit0	00000000
Address: 0x5B								

**BUFE** controls activation of the sample buffer.

*BUFE = 0 – sample buffer inactive*

*BUFE = 1 – sample buffer active*

*Note: FIFO SRAM is powered only during BUFE=1 and PC1(CNTL1)=1.*

*Note: Disabling the sample buffer (BUFE = 0) will clear the buffer.*

*The buffer is cleared as well:*

*1) Following write to BUF\_CLEAR register*

*or*

*2) After setting PC1 bit in CNTL1 register to 0 (standby mode).*

**BRES** determines the resolution of the acceleration data samples collected by the sample buffer.

*BRES = 0 – 8-bit samples are accumulated in the buffer*

*BRES = 1 – 16-bit samples are accumulated in the buffer*

**BFIE** buffer full interrupt enable bit

*BFIE = 0 – buffer full interrupt is disabled*

*BFIE = 1 – buffer full interrupt is enabled and updated in INS2*

**BM1, BM0** selects the operating mode of the sample buffer per Table 23



# ± 2g / 4g / 8g Tri-axis Digital Accelerometer Specifications

**PART NUMBER:**  
**KX126-1063**  
**Rev. 1.0**  
**22-Jun-17**

BM1	BM0	Mode	Description
0	0	FIFO	The buffer collects 683 sets of 8-bit low resolution values or 342 sets of 16-bit high resolution values and then stops collecting data, collecting new data only when the buffer is not full.
0	1	Stream	The buffer holds the last 683 sets of 8-bit low resolution values or 342 sets of 16-bit high resolution values. Once the buffer is full, the oldest data is discarded to make room for newer data.
1	0	Trigger	When a trigger event occurs, the buffer holds the last data set of SMP[9:0] samples before the trigger event and then continues to collect data until full. New data is collected only when the buffer is not full.
1	1	FILO	The buffer holds the last 683 sets of 8-bit low resolution values or 342 sets of 16-bit high resolution values. Once the buffer is full, the oldest data is discarded to make room for newer data. Reading from the buffer in this mode will return the most recent data first.

**Table 23:** Selected Buffer Mode

## BUF\_STATUS\_1 and BUF\_STATUS\_2

These register reports the status of the sample buffer. Note that BUF\_STATUS\_1 and BUF\_STATUS\_2 registers may have a delay of up to 1µsec to update the sample level after a buffer read.

R	R	R	R	R	R	R	R	BUF_STATUS_1
SMP_LEV7	SMP_LEV6	SMP_LEV5	SMP_LEV4	SMP_LEV3	SMP_LEV2	SMP_LEV1	SMP_LEV0	Reset Value
Bit7	Bit6	Bit5	Bit4	Bit3	Bit2	Bit1	Bit0	00000000
Address: 0x5C								

R	R	R	R	R	R	R	R	BUF_STATUS_2
BUF_TRIG	0	0	0	SMP_LEV11	SMP_LEV10	SMP_LEV9	SMP_LEV8	Reset Value
Bit7	Bit6	Bit5	Bit4	Bit3	Bit2	Bit1	Bit0	00000000
Address: 0x5D								

**SMP\_LEV[11:0] Sample Level;** reports the number of data bytes that have been stored in the sample buffer. When BRES=1, this count will increase by 6 for each 3-axis sample in the buffer; when BRES=0, the count will increase by 3 for each 3-axis sample. If this register reads 0, no data has been stored in the buffer.

**BUF\_TRIG** reports the status of the buffer's trigger function if this mode has been selected.  
 A trigger event is the combined interrupt events of  
**BUF\_TRIG = FFS | TDTS1 | TDTS0 | WUFS | TPS | STPWMI | TRIG**

	<b>± 2g / 4g / 8g Tri-axis Digital Accelerometer Specifications</b>	<b>PART NUMBER:</b> <b>KX126-1063</b> <b>Rev. 1.0</b> <b>22-Jun-17</b>
---	---	---

### BUF\_CLEAR

Latched buffer status information and the entire sample buffer are cleared when any data is written to this register. This causes the sample level bits SMP\_LEV[11:0] to be cleared in BUF\_STATUS\_1 and BUF\_STATUS\_2 registers. In addition, if the sample buffer is set to Trigger mode, the BUF\_TRIG bit in BUF\_STATUS\_2 is cleared too. Finally, the BFI and WMI bits in INS2 will be cleared and physical interrupt latched pin will be changed to its inactive state.

W	W	W	W	W	W	W	W	
X	X	X	X	X	X	X	X	Reset Value
Bit7	Bit6	Bit5	Bit4	Bit3	Bit2	Bit1	Bit0	00000000
Address: 0x5E								

### BUF\_READ

Buffer output register: Data in the buffer can be read according to the BRES and BM settings in BUF\_CTRL2 by executing this command. More samples can be retrieved by continuing to toggle SCL after the read command is executed. Data should only be read by set (6 bytes for high-resolution samples and 3 bytes for low-resolution samples) and by using auto-increment. Additional samples cannot be written to the buffer while data is being read from the buffer using auto-increment mode. Output data is in 2's Complement format.

R	R	R	R	R	R	R	R	
X	X	X	X	X	X	X	X	Reset Value
Bit7	Bit6	Bit5	Bit4	Bit3	Bit2	Bit1	Bit0	00000000
Address: 0x5F								

	<b>± 2g / 4g / 8g Tri-axis Digital Accelerometer Specifications</b>	<b>PART NUMBER:</b> <b>KX126-1063</b> <b>Rev. 1.0</b> <b>22-Jun-17</b>
---	---	---

## Embedded Applications

### Orientation Detection Feature

The orientation detection feature of the KX126 will report changes in face up, face down, ± vertical and ± horizontal orientation. This intelligent embedded algorithm considers very important factors that provide accurate orientation detection from low cost tri-axis accelerometers. Factors such as: hysteresis, device orientation angle and delay time are described below as these techniques are utilized inside the KX126

#### Hysteresis

A 45° tilt angle threshold seems like a good choice because it is halfway between 0° and 90°. However, a problem arises when the user holds the device near 45°. Slight vibrations, noise and inherent sensor error will cause the acceleration to go above and below the threshold rapidly and randomly, so the screen will quickly flip back and forth between the 0° and the 90° orientations. This problem is avoided in the KX126 by choosing a 30° threshold angle. With a 30° threshold, the screen will not rotate from 0° to 90° until the device is tilted to 60° (30° from 90°). To rotate back to 0°, the user must tilt back to 30°, thus avoiding the screen flipping problem. This example essentially applies ± 15° of hysteresis in between the four screen rotation states. Table 24 shows the acceleration limits implemented for  $\phi_T = 30^\circ$ .

Orientation	X Acceleration (g)	Y Acceleration (g)
0°/360°	$-0.5 < a_x < 0.5$	$a_y > 0.866$
90°	$a_x > 0.866$	$-0.5 < a_y < 0.5$
180°	$-0.5 < a_x < 0.5$	$a_y < -0.866$
270°	$a_x < -0.866$	$-0.5 < a_y < 0.5$

**Table 24:** Acceleration at the four orientations with ± 15° of hysteresis

The KX126 allows the user to change the amount of hysteresis in between the four screen rotation states. By simply writing to the HYST\_SET register, the user can adjust the amount of hysteresis up to ± 45°. The plot in Figure 10 shows the typical amount of hysteresis applied for a given digital count value of HYST\_SET.





# ± 2g / 4g / 8g Tri-axis Digital Accelerometer Specifications

**PART NUMBER:**  
KX126-1063  
Rev. 1.0  
22-Jun-17

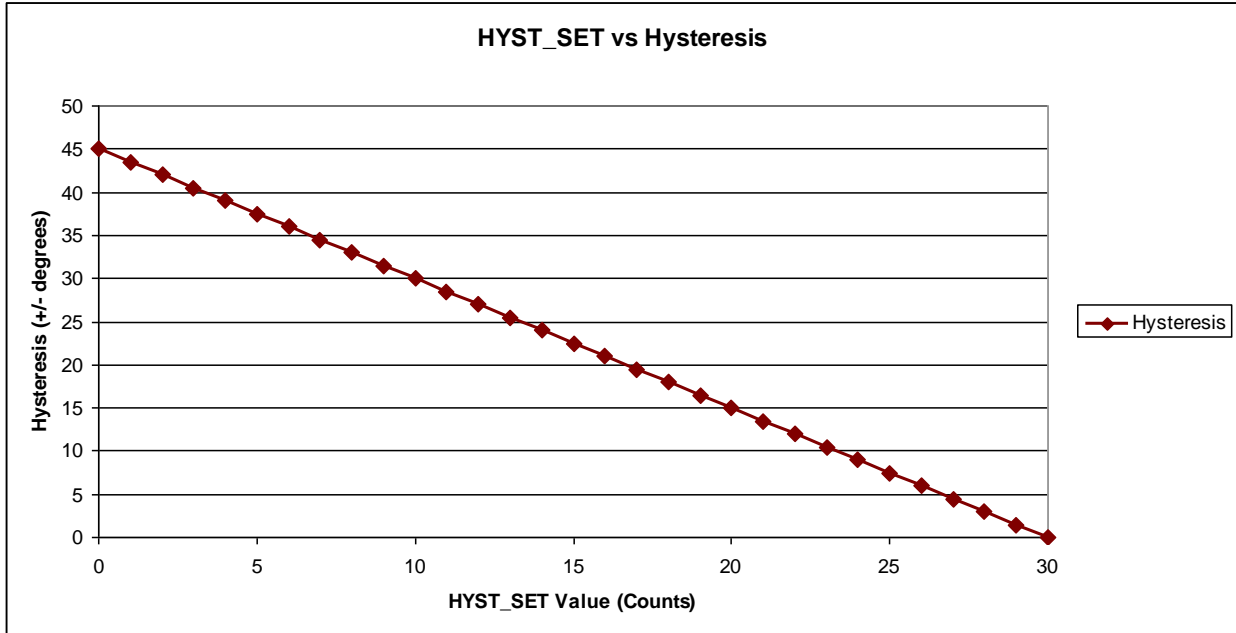

**Figure 10:** HYST\_SET vs Hysteresis

## Device Orientation Angle (aka Tilt Angle)

To ensure that horizontal and vertical device orientation changes are detected, even when it isn't in the ideal vertical orientation – where the angle  $\theta$  in Figure 11 is  $90^\circ$ , the KX126 considers device orientation angle in its algorithm.

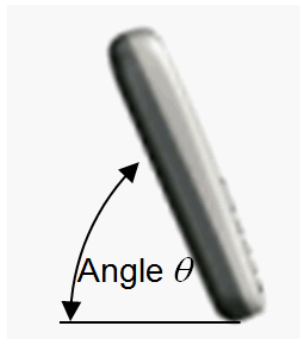

**Figure 11:** Device Orientation Angle

As the angle in Figure 11 is decreased, the maximum gravitational acceleration on the X-axis or Y-axis will also decrease. Therefore, when the angle becomes small enough, the user will not be able to make the screen

	<b>± 2g / 4g / 8g Tri-axis Digital Accelerometer Specifications</b>	<b>PART NUMBER:</b> <b>KX126-1063</b> <b>Rev. 1.0</b> <b>22-Jun-17</b>
---	---	---

orientation change. When the device orientation angle approaches 0° (device is flat on a desk or table),  $a_x = a_y = 0g$ ,  $a_z = +1g$ , and there is no way to determine which way the screen should be oriented, the internal algorithm determines that the device is in either the face-up or face-down orientation, depending on the sign of the z-axis. The KX126 will only change the screen orientation when the orientation angle is above the factory-defaulted/user-defined threshold set in the TILT\_ANGLE\_LL register. Equation 3 can be used to determine what value to write to the TILT\_ANGLE\_LL register to set the device orientation angle. The value for HL is preset at the factory but can be adjusted in special cases (e.g. to reduce the effect of transient g-variation such as when device is being moved rather than just being rotated).

$$\text{TILT\_ANGLE\_LL (counts)} = \sin \theta * (32 \text{ (counts/g)})$$

**Equation 3:** Tilt Angle Threshold

**Tilt Timer**

The 8-bit register, TILT\_TIMER can be used to qualify changes in orientation. The KX126 does this by incrementing a counter with a size that is specified by the value in TSC for each set of acceleration samples to verify that a change to a new orientation state is maintained. A user defined output data rate (ODR) determines the time period for each sample. Equation 4 shows how to calculate the TILT\_TIMER register value for a desired delay time.

$$\text{TILT\_TIMER (counts)} = \text{Delay Time (sec)} \times \text{ODR (Hz)}$$

**Equation 4:** Tilt Position Delay Time

	<b>± 2g / 4g / 8g Tri-axis Digital Accelerometer Specifications</b>	<b>PART NUMBER:</b> <b>KX126-1063</b> <b>Rev. 1.0</b> <b>22-Jun-17</b>
---	---	---

## Motion Interrupt Feature Description

The Motion interrupt feature of the KX126 reports qualified changes in the high-pass filtered acceleration based on the Wake Up (WUFTH) threshold and Back-to-Sleep threshold (BTSTH). If the high-pass filtered acceleration on any axis is greater than the user-defined wake up threshold (WUFTH), the device has transitioned from an inactive state to an active state. On the other hand if the high-pass filtered acceleration on any axis is less than the user-defined Back to sleep threshold (BTSTH), the device has transitioned from an active state to an inactive state. Equation 5 shows how to calculate the WUFTH and BTSTH register value for a desired wake up threshold. The wake-up engine function is independent of the user selected g-range and resolution.

$$\begin{aligned} \text{WUFTH (counts)} &= \text{Wake Up Threshold (g)} \times 256 \text{ (counts/g)} \\ \text{BTSTH (counts)} &= \text{Back to Sleep Threshold (g)} \times 256 \text{ (counts/g)} \end{aligned}$$

### Equation 5: Wake-Up/Back-to-Sleep Threshold

An 8-bit raw unsigned value represents a counter that permits the user to qualify each active/inactive state change. Note that each WUFC Timer count qualifies 1 (one) user-defined ODR period, OWUF and each BTSC Time count qualifies 1 (one) user-defined ODR period, OBTS. Equation 6 shows how to calculate the WUFC and BTSC register values for a desired wake up or back to sleep delay time.

$$\begin{aligned} \text{WUFC (counts)} &= \text{Wake Up Delay Time (sec)} \times \text{OWUF (Hz)} \\ \text{BTSC (counts)} &= \text{Back to Sleep Delay Time (sec)} \times \text{OBTS (Hz)} \end{aligned}$$

### Equation 6: Wake Up and Back to Sleep counts

**Wake up function:** While the part is in inactive state, the algorithm evaluates differential measurement between each new acceleration data point with the preceding one and evaluates it against the WUFTH threshold. When the differential measurement is greater than WUFTH threshold, the wakeup counter starts the count. Differential measurements are now calculated based on the difference between the current acceleration and the acceleration when the counter started. The part will report that motion has occurred at the end of the count assuming each differential measurement has remained above the threshold. If at any moment during the count the differential measurement falls below the threshold, the counter will stop the count and the part will remain in inactive state.

Figure 12 shows the latched response of the motion detection algorithm with WUF Timer (WUFC) set to 10 counts. Note how the difference between the acceleration sample marked in red and the one marked in green resulted in a differential measurements represented with orange bar being above the WUF threshold. At this point, the counter begins to count number of counts stored in WUFC register and the wakeup algorithm will evaluate the difference between each new acceleration measurement and the measurement marked in green that will remain a reference measurement for the duration of the counter count. At the end of the count, assuming all differential measurements were larger than WUF threshold, as is the case in the example showed in Figure 12 a motion event will be reported.



# ± 2g / 4g / 8g Tri-axis Digital Accelerometer Specifications

**PART NUMBER:**  
**KX126-1063**  
**Rev. 1.0**  
**22-Jun-17**

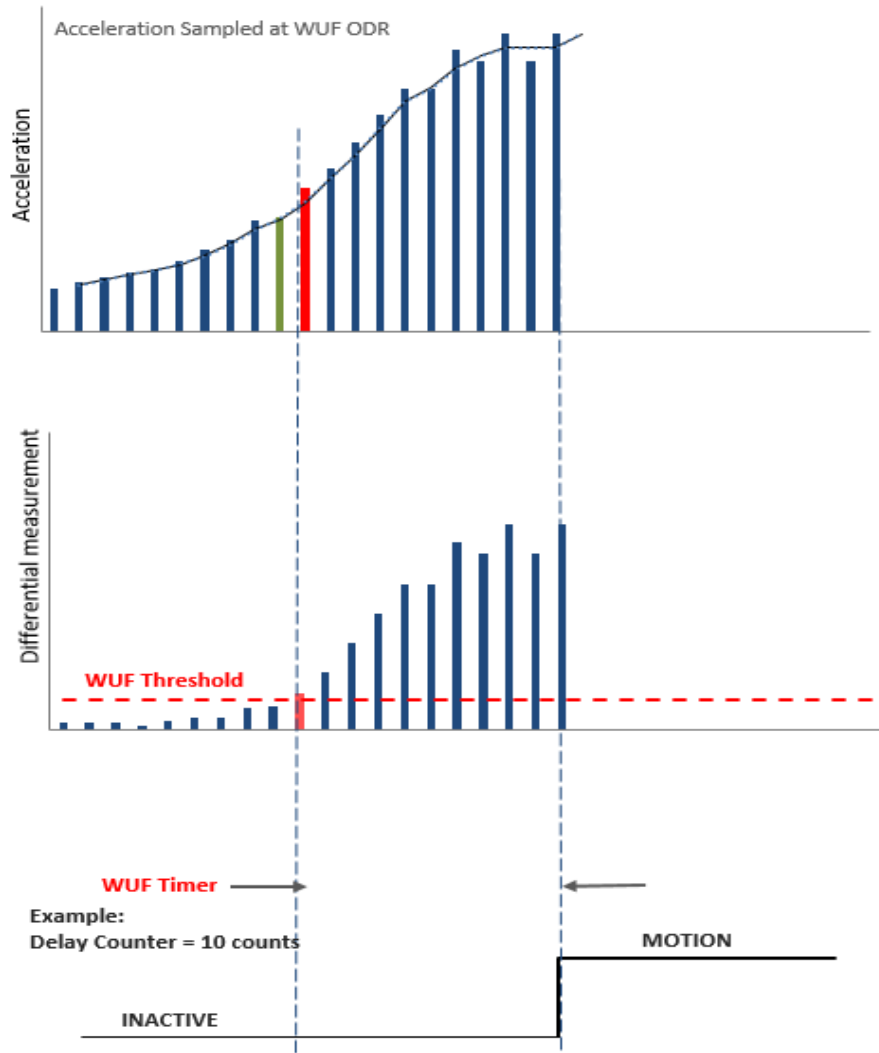

**Figure 12: Latched Motion Interrupt Response with WUFC**

**Back to sleep function:** While the part is in active state, the algorithm evaluates differential measurement between each new acceleration data point with the preceding one and evaluates it against the BTSTH threshold. When the differential measurement is less than BTSTH threshold, the back-to-sleep counter starts the count. Differential measurements are now calculated based on the difference between the current acceleration and the acceleration when the counter started. The part will report that motion has not occurred at the end of the count assuming each differential measurement has remained below the threshold. If at any moment during the count the differential measurement goes above the threshold, the counter will stop the count and the part will remain in active state.



# ± 2g / 4g / 8g Tri-axis Digital Accelerometer Specifications

**PART NUMBER:**  
KX126-1063  
Rev. 1.0  
22-Jun-17

Figure 13 shows the latched response of the motion detection algorithm with BTS Timer (BTSC) set to 10 counts. Note how the difference between the acceleration sample marked in red and the one marked in green resulted in a differential measurements represented with orange bar being below the BTS threshold. At this point, the counter begins to count number of counts stored in BTSC register and the back-to-sleep algorithm will evaluate the difference between each new acceleration measurement and the measurement marked in green that will remain a reference measurement for the duration of the counter count. At the end of the count, assuming all differential measurements were below BTS threshold, as is the case in the example showed in Figure 13 an inactive mode will be reported.

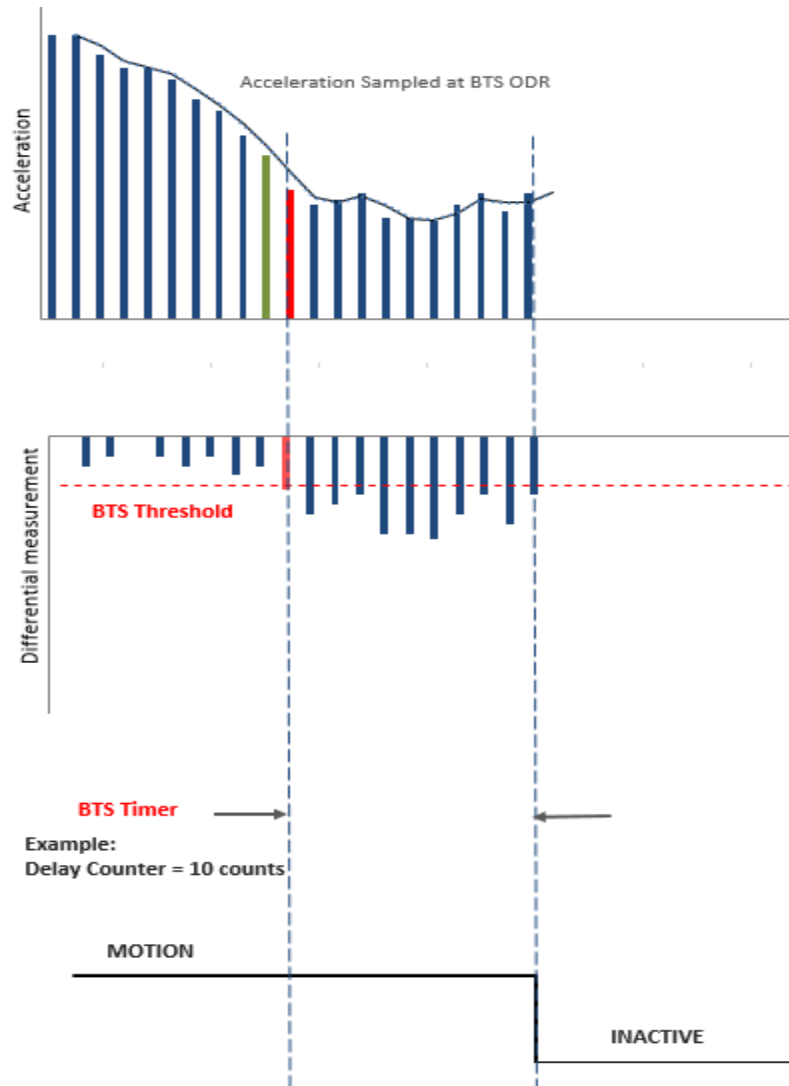

**Figure 13:** Latched Motion Interrupt Response with BTSC

### Directional Tap Detection Feature Description

The Directional Tap Detection feature of the KX126 recognizes single and double tap inputs and reports the acceleration axis and direction that each tap occurred. Eight performance parameters, as well as a user-selectable ODR are used to configure the KX126 for a desired tap detection response.

### Performance Index

The Directional Tap™ detection algorithm uses low and high thresholds to help determine when a tap event has occurred. A tap event is detected when the previously described jerk summation exceeds the low *threshold (TTL)* for more than the tap detection low limit, but less than the tap detection high limit as contained in FTD. Samples that exceed the high limit (TTH) will be ignored. Figure 14 shows an example of a single tap event meeting the performance index criteria.

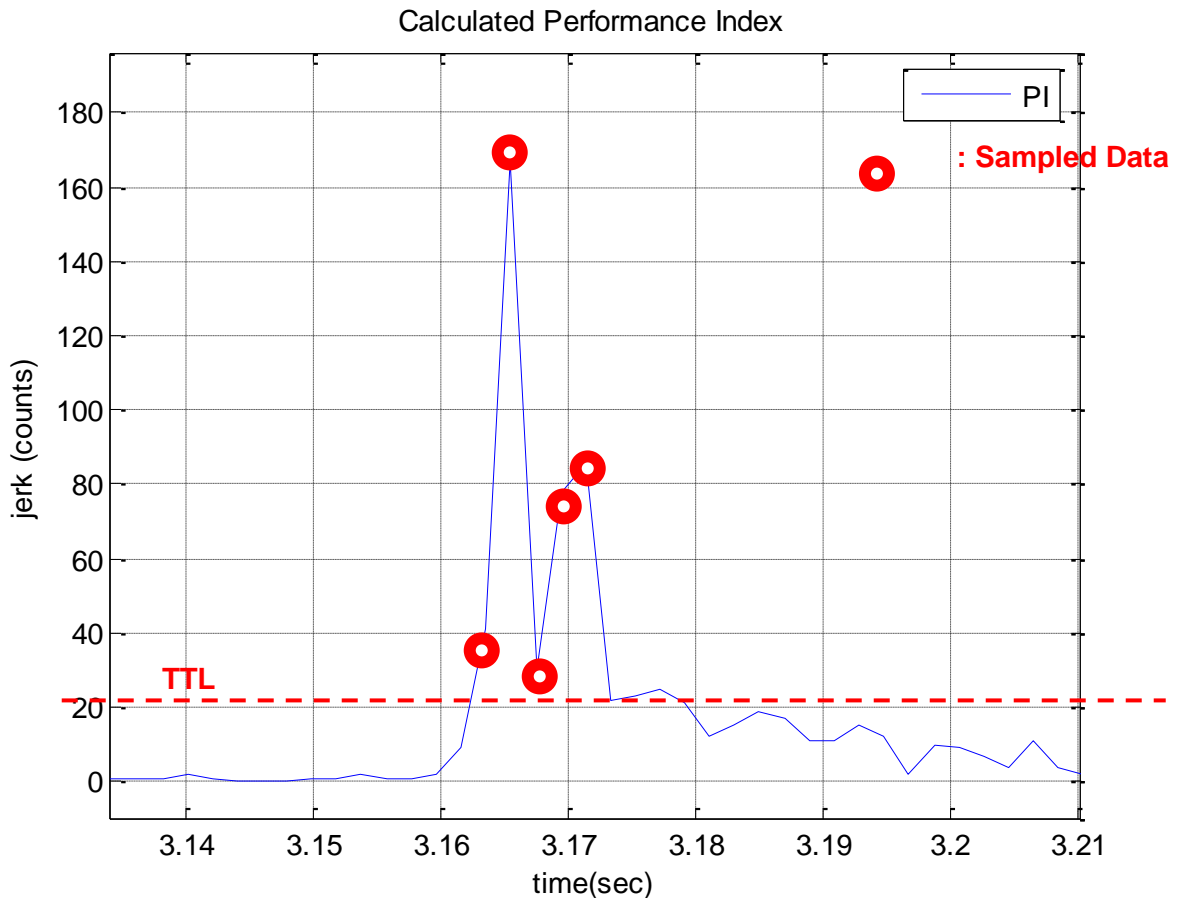

**Figure 14: Jerk Summation vs Threshold**



# ± 2g / 4g / 8g Tri-axis Digital Accelerometer Specifications

**PART NUMBER:**  
KX126-1063  
Rev. 1.0  
22-Jun-17

## Single Tap Detection

The latency timer (TLT) sets the time period that a tap event will only be characterized as a single tap. A second tap has to occur outside of the latency timer. If a second tap occurs inside the latency time, it will be ignored as it occurred too quickly. The single tap will be reported at the end of the TWS. Figure 15 shows a single tap event meeting the PI, latency and window requirements.

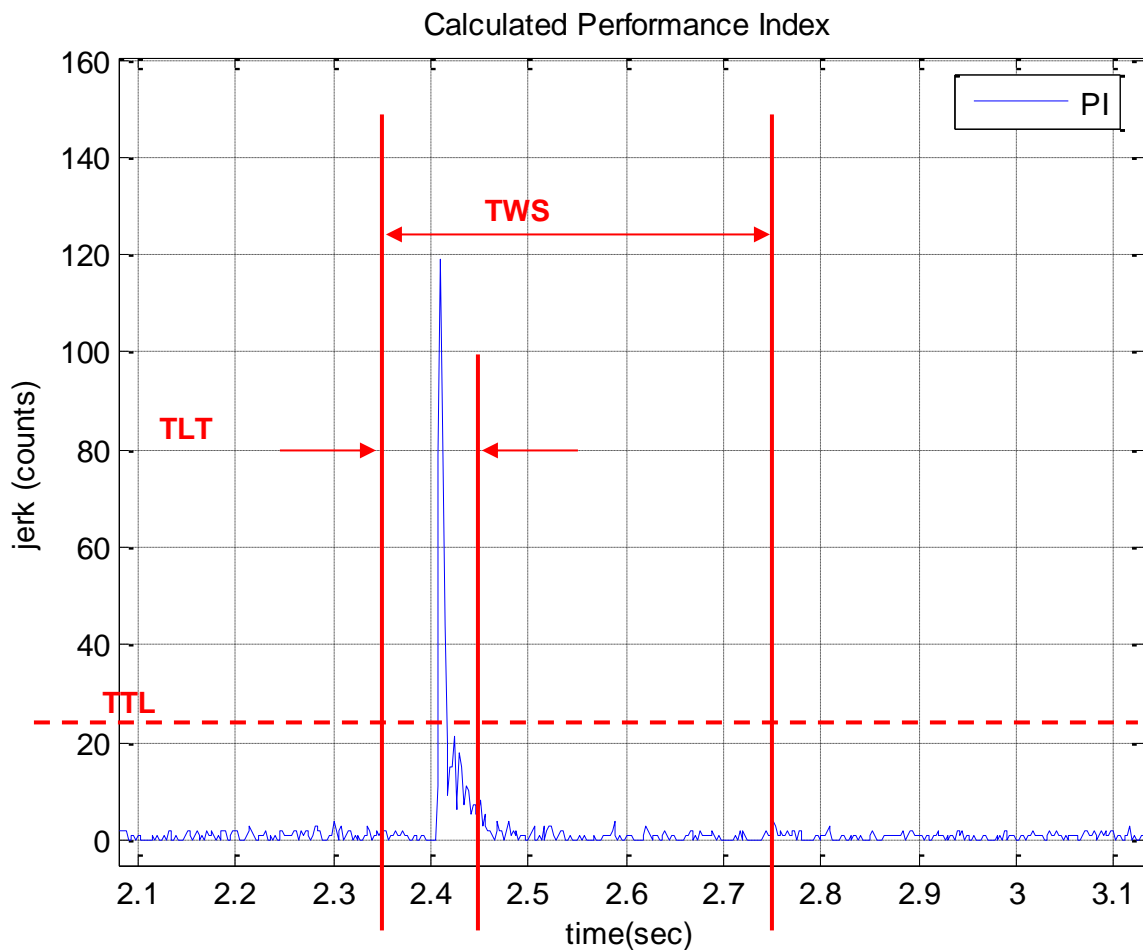

**Figure 15:** Single Directional Tap™ Timing



# ± 2g / 4g / 8g Tri-axis Digital Accelerometer Specifications

**PART NUMBER:**  
KX126-1063  
Rev. 1.0  
22-Jun-17

## Double Tap Detection

An event can be characterized as a double tap if the second tap crosses the performance index (TTL) inside the TWS period and ends outside the TDTC. This means that the TDTC determines the minimum time separation that must exist between the two taps of a double tap event. Similar to the single tap, the first tap event must exceed the performance index for the time limit contained in FTD. Also, the duration when the first and second events combined exceed the performance index should not exceed STD. The double tap will be reported at the end of the second TLT. Figure 16 shows a double tap event meeting the PI, latency and window requirements.

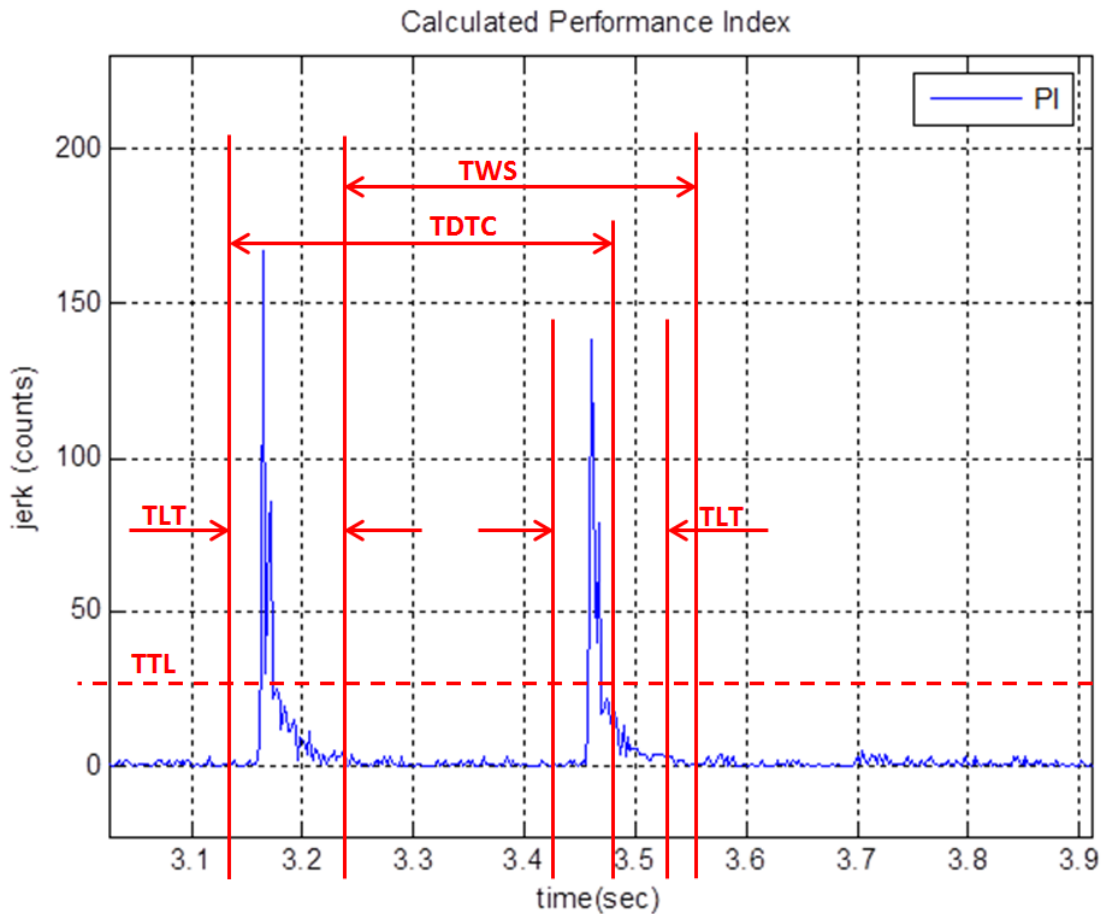

**Figure 16:** Double Directional Tap™ Timing



	<b>± 2g / 4g / 8g Tri-axis Digital Accelerometer Specifications</b>	<b>PART NUMBER:</b> <b>KX126-1063</b> <b>Rev. 1.0</b> <b>22-Jun-17</b>
---	---	---

## Free fall Detect

The KX126 features a Free fall interrupt that sends a flag through INT1 or INT2 when the accelerometer senses a Free fall event. A Free fall event is evident when all three accelerometer axes simultaneously fall below a certain acceleration threshold for a set amount of time. The KX126 gives the user the option to define the acceleration threshold value through the FFTH 8-bit register where 256 counts cover the g range of the accelerometer. This value is compared to the top 8 bits of the accelerometer 8g output.

Through the Free Fall Counter (FFC), the user can set the amount of time all three accelerometer axes must simultaneously remain below the FFTH acceleration threshold before the Free fall interrupt flag is sent through INT1 or INT2. This delay/debounce time is defined by the available 0 to 255 counts, which represent accelerometer samples taken at the rate defined by OFFI<2:0>. Every count is calculated as 1/ODR delay period.

When the Free fall interrupt is enabled the part must not be in a physical state that would trigger the Free fall interrupt or the delay will not be correct for the present Free fall.



# ± 2g / 4g / 8g Tri-axis Digital Accelerometer Specifications

**PART NUMBER:**  
KX126-1063  
Rev. 1.0  
22-Jun-17

## Typical Freefall Interrupt Example (nonLatching)

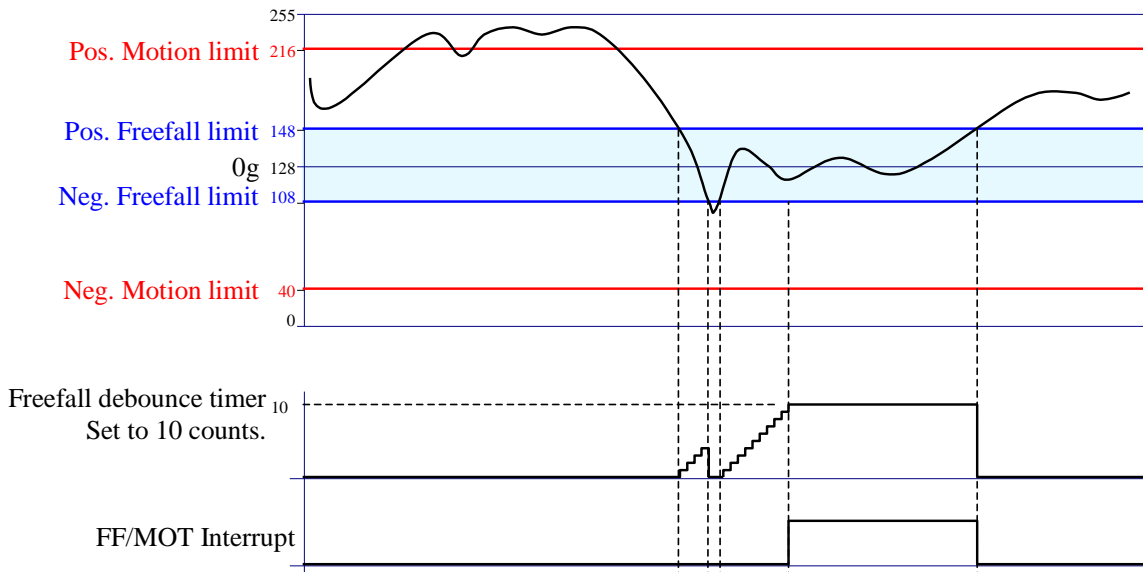

**Figure 17:** Typical Free fall Interrupt Example (FFCNTL ULMODE = 1)

## Typical Freefall Interrupt Example (Latching)

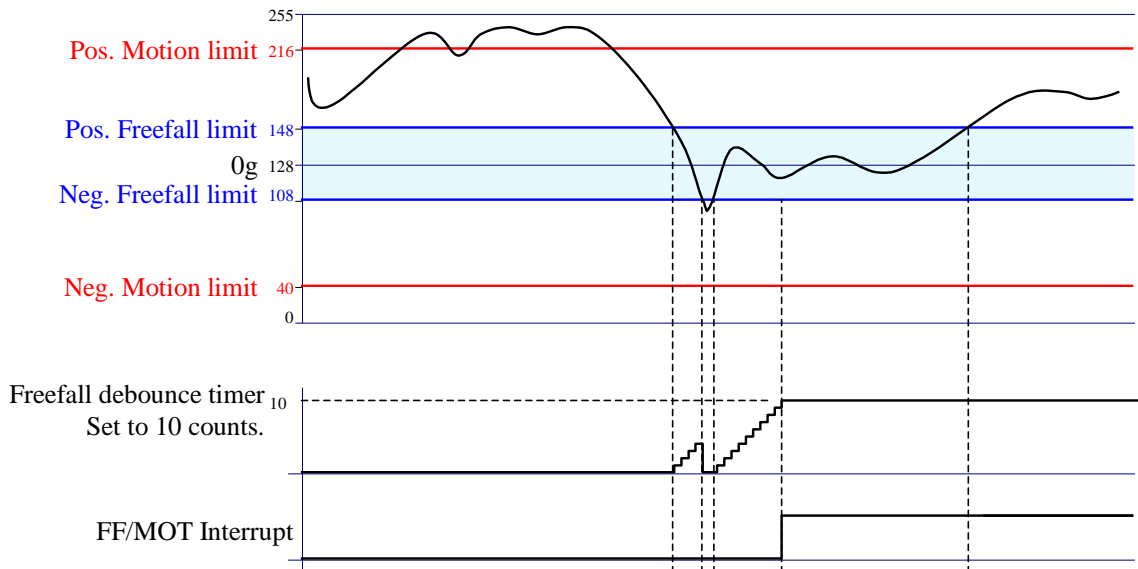

**Figure 18:** Typical Free fall Interrupt Example (FFCNTL ULMODE = 0)

	<b>± 2g / 4g / 8g Tri-axis Digital Accelerometer Specifications</b>	<b>PART NUMBER:</b> <b>KX126-1063</b> <b>Rev. 1.0</b> <b>22-Jun-17</b>
---	---	---

## Sample Buffer Feature Description

The sample buffer feature of the KX126 accumulates and outputs acceleration data based on how it is configured. There are 4 buffer modes available, and samples can be accumulated at either low (8-bit) or high (16-bit) resolution. Acceleration data is collected at the ODR specified by OSA[3:0] in the ODCNTL register. Each buffer mode accumulates data, reports data, and interacts with status indicators in a slightly different way.

### FIFO Mode

#### Data Accumulation

Sample collection stops when the buffer is full.

#### Data Reporting

Data is reported with the oldest byte of the oldest sample first (X\_L or X based on resolution).

#### Status Indicators

A watermark interrupt occurs when the number of samples in the buffer reaches the Sample Threshold. The watermark interrupt stays active until the buffer contains less than this number of samples. This can be accomplished through clearing the buffer or explicitly reading greater than SMPX samples (calculated with Equation 7).

BUF\_RES=0:

$$SMPX = SMP\_LEV[11:0] / 3 - SMP\_TH[9:0]$$

BUF\_RES=1:

$$SMPX = SMP\_LEV[11:0] / 6 - SMP\_TH[9:0]$$

**Equation 7: Samples Above Sample Threshold**

### Stream Mode

#### Data Accumulation

Sample collection continues when the buffer is full; older data is discarded to make room for newer data.

#### Data Reporting

Data is reported with the oldest sample first (uses FIFO read pointer).

#### Status Indicators

A watermark interrupt occurs when the number of samples in the buffer reaches the Sample Threshold. The watermark interrupt stays active until the buffer contains less than this number of samples. This can be accomplished through clearing the buffer or explicitly reading greater than SMPX samples (calculated with ).

	<b>± 2g / 4g / 8g Tri-axis Digital Accelerometer Specifications</b>	<b>PART NUMBER:</b> <b>KX126-1063</b> <b>Rev. 1.0</b> <b>22-Jun-17</b>
---	---	---

## Trigger Mode

### Data Accumulation

When a physical interrupt is caused by one of the digital engines or when a logic high signal occurs on the TRIG pin, the trigger event is asserted and SMP\_TH[9:0] samples prior to the event are retained. Sample collection continues until the buffer is full.

### Data Reporting

Data is reported with the oldest sample first (uses FIFO read pointer).

### Status Indicators

When a physical interrupt occurs and there are at least SMP\_TH[9:0] samples in the buffer, BUF\_TRIG in BUF\_STATUS\_2 is asserted.

## FILO Mode

### Data Accumulation

Sample collection continues when the buffer is full; older data is discarded to make room for newer data.

### Data Reporting

Data is reported with the newest byte of the newest sample first (Z\_H or Z based on resolution).

### Status Indicators

A watermark interrupt occurs when the number of samples in the buffer reaches the Sample Threshold. The watermark interrupt stays active until the buffer contains less than this number of samples. This can be accomplished through clearing the buffer or explicitly reading greater than SMPX samples (calculated with Equation 7).

## Buffer Operation

The following diagrams illustrate the operation of the buffer conceptually. Actual physical implementation has been abstracted to offer a simplified explanation of how the different buffer modes operate. Figure 19 represents a high-resolution 3-axis sample within the buffer. Figure 20 – Figure 27 represent a 10-sample version of the buffer (for simplicity), with Sample Threshold set to 8.

Regardless of the selected mode, the buffer fills sequentially, one byte at a time. Figure 19 shows one 6-byte data sample. Note the location of the FILO read pointer versus that of the FIFO read pointer.



# ± 2g / 4g / 8g Tri-axis Digital Accelerometer Specifications

**PART NUMBER:**  
**KX126-1063**  
 Rev. 1.0  
 22-Jun-17

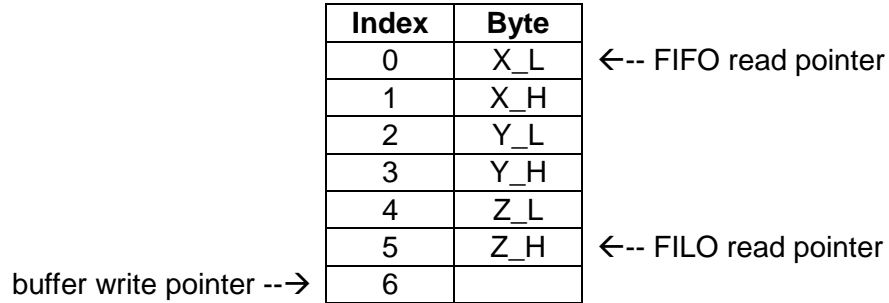

**Figure 19: One Buffer Sample**

Regardless of the selected mode, the buffer fills sequentially, one sample at a time. Note in Figure 20 the location of the FILO read pointer versus that of the FIFO read pointer. The buffer write pointer shows where the next sample will be written to the buffer.

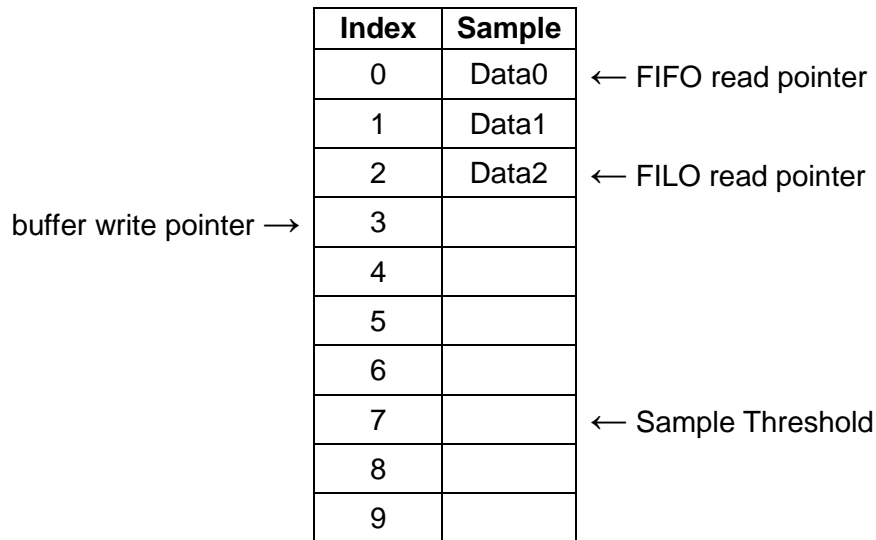

**Figure 20: Buffer Filling**

The buffer continues to fill sequentially until the Sample Threshold is reached. Note in Figure 20 the location of the FILO read pointer versus that of the FIFO read pointer.

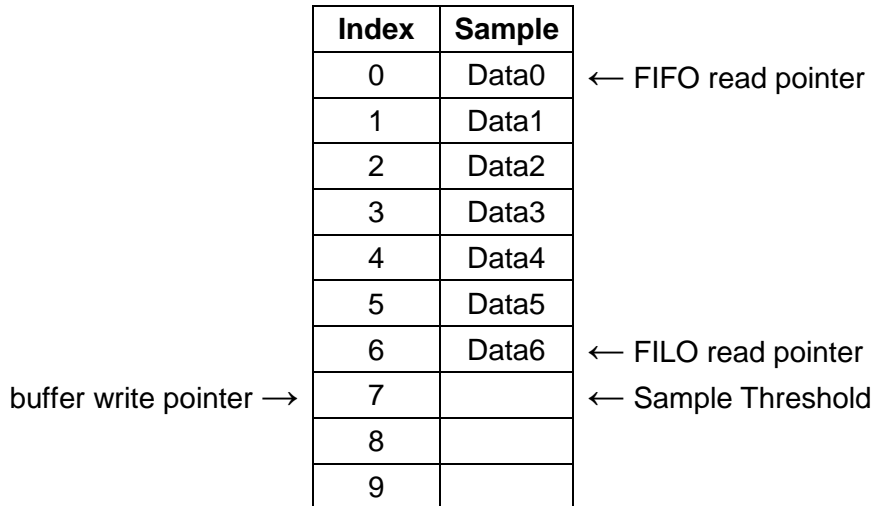

**Figure 20: Buffer Approaching Sample Threshold**

In FIFO, Stream, and FILO modes, a watermark interrupt is issued when the number of samples in the buffer reaches the Sample Threshold. In trigger mode, this is the point where the oldest data in the buffer is discarded to make room for newer data.

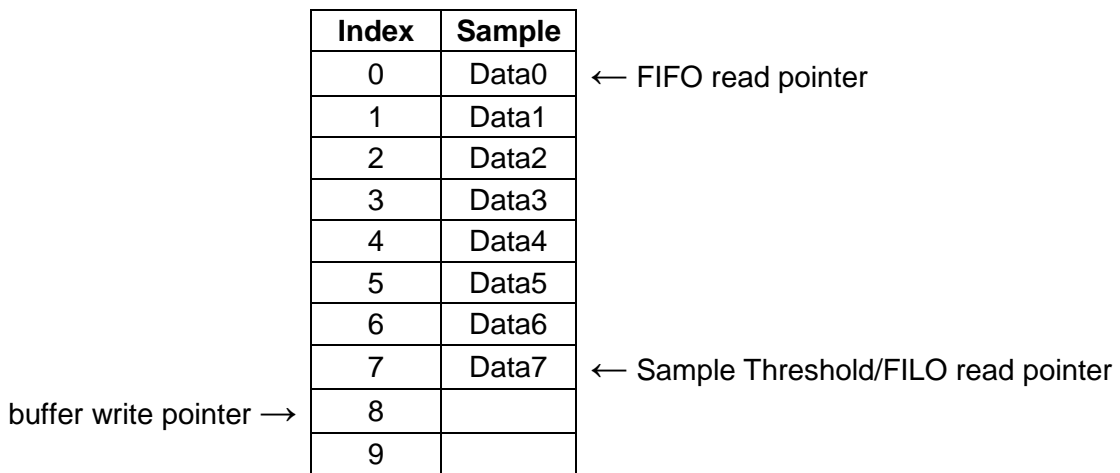

**Figure 21: Buffer at Sample Threshold**



# ± 2g / 4g / 8g Tri-axis Digital Accelerometer Specifications

**PART NUMBER:**  
**KX126-1063**  
 Rev. 1.0  
 22-Jun-17

In trigger mode, data is accumulated in the buffer sequentially until the Sample Threshold is reached. Once the Sample Threshold is reached, the oldest samples are discarded when new samples are collected. Note in Figure 22 how Data0 was thrown out to make room for Data8.

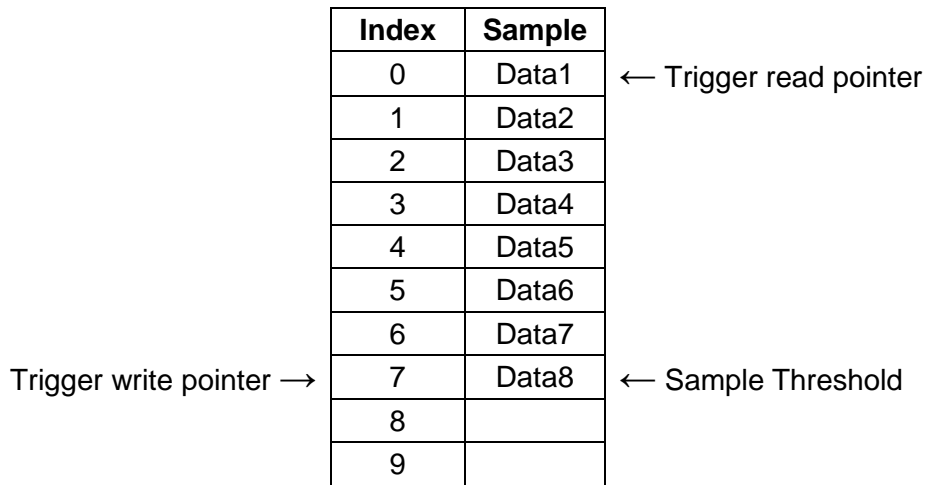

**Figure 22:** Additional Data Prior to Trigger Event

After a trigger event occurs, the buffer no longer discards the oldest samples, and instead begins accumulating samples sequentially until full. The buffer then stops collecting samples, as seen in Figure 23. This results in the buffer holding SMP\_TH[9:0] samples prior to the trigger event, and SMPX samples after the trigger event.

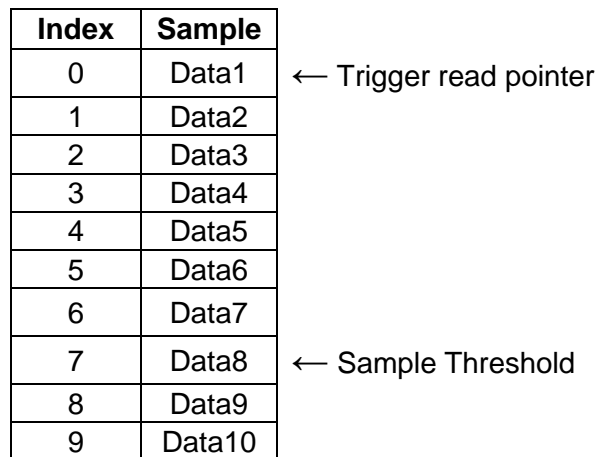

**Figure 23:** Additional Data after Trigger Event

In FIFO, Stream, FILO, and Trigger (after a trigger event has occurred) modes, the buffer continues filling sequentially after the Sample Threshold is reached. Sample accumulation after

the buffer is full depends on the selected operation mode. FIFO and Trigger modes stop accumulating samples when the buffer is full, and Stream and FILO modes begin discarding the oldest data when new samples are accumulated.

Index	Sample	
0	Data0	← FIFO read pointer
1	Data1	
2	Data2	
3	Data3	
4	Data4	
5	Data5	
6	Data6	
7	Data7	← Sample Threshold
8	Data8	
9	Data9	← FILO read pointer

**Figure 24:** Buffer Full

After the buffer has been filled in FILO or Stream mode, the oldest samples are discarded when new samples are collected. Note in Figure 25 how Data0 was thrown out to make room for Data10.

Index	Sample	
0	Data1	← FIFO read pointer
1	Data2	
2	Data3	
3	Data4	
4	Data5	
5	Data6	
6	Data7	
7	Data8	← Sample Threshold
8	Data9	
9	Data10	← FILO read pointer

**Figure 25:** Buffer Full – Additional Sample Accumulation in Stream or FILO Mode





# ± 2g / 4g / 8g Tri-axis Digital Accelerometer Specifications

**PART NUMBER:**  
**KX126-1063**  
 Rev. 1.0  
 22-Jun-17

In FIFO, Stream, or Trigger mode, reading one sample from the buffer will remove the oldest sample and effectively shift the entire buffer contents up, as seen in Figure 26.

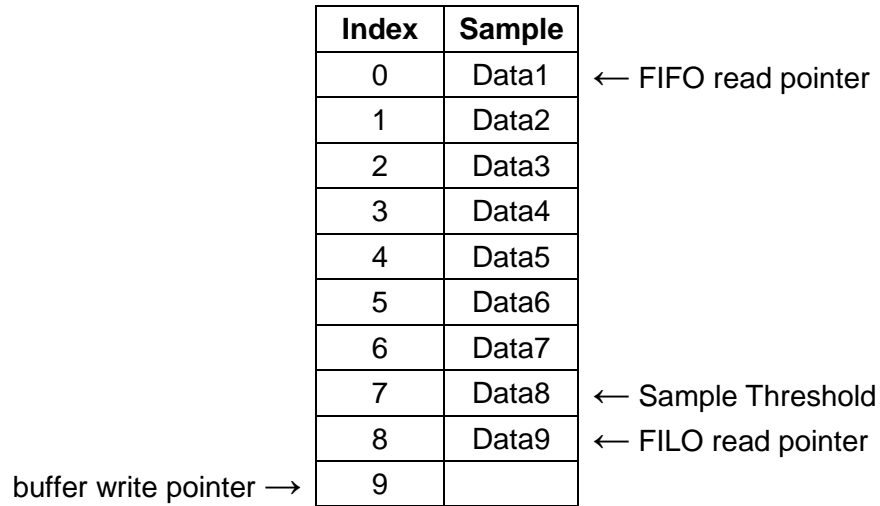

**Figure 26: FIFO Read from Full Buffer**

In FILO mode, reading one sample from the buffer will remove the newest sample and leave the older samples untouched, as seen in Figure 27.

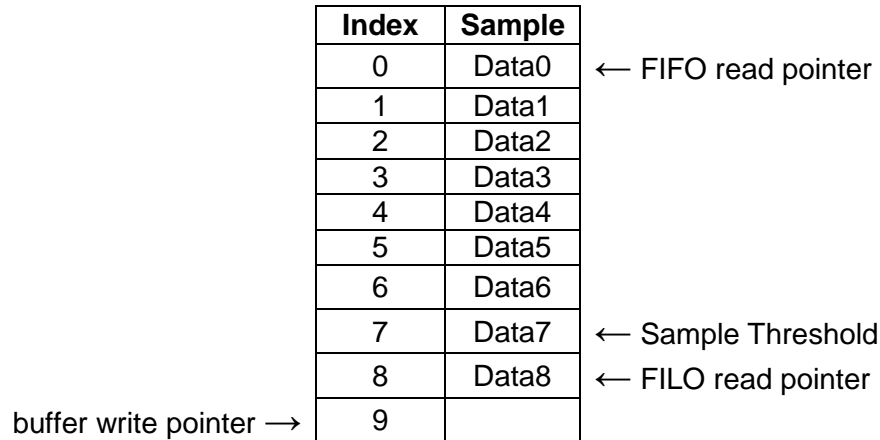

**Figure 27: FILO Read from Full Buffer**

	<b>± 2g / 4g / 8g Tri-axis Digital Accelerometer Specifications</b>	<b>PART NUMBER:</b> <b>KX126-1063</b> <b>Rev. 1.0</b> <b>22-Jun-17</b>
---	---	---

**Pedometer (Step Counter) Feature**

Please refer to Application Note [AN073 Getting Started with Pedometer](#) for more information.

	<b>± 2g / 4g / 8g Tri-axis Digital Accelerometer Specifications</b>	<b>PART NUMBER:</b> <b>KX126-1063</b> <b>Rev. 1.0</b> <b>22-Jun-17</b>
---	---	---

### Revision History

Revision	DESCRIPTION	Date
1.0	Initial Release	22-JUN-2017

"Kionix" is a registered trademark of Kionix, Inc. Products described herein are protected by patents issued or pending. No license is granted by implication or otherwise under any patent or other rights of Kionix. The information contained herein is believed to be accurate and reliable but is not guaranteed. Kionix does not assume responsibility for its use or distribution. Kionix also reserves the right to change product specifications or discontinue this product at any time without prior notice. This publication supersedes and replaces all information previously supplied.

	<b>± 2g / 4g / 8g Tri-axis Digital Accelerometer Specifications</b>	<b>PART NUMBER:</b> <b>KX126-1063</b> <b>Rev. 1.0</b> <b>22-Jun-17</b>
---	---	---

## Appendix

The following Notice is included to guide the use of Kionix products in its application and manufacturing processes. Kionix, Inc., is a ROHM Group company. For purposes of this Notice, the name “ROHM” would also imply Kionix, Inc.

# Notice

## Precaution on using ROHM Products

- Our Products are designed and manufactured for application in ordinary electronic equipments (such as AV equipment, OA equipment, telecommunication equipment, home electronic appliances, amusement equipment, etc.). If you intend to use our Products in devices requiring extremely high reliability (such as medical equipment <sup>(Note 1)</sup>, transport equipment, traffic equipment, aircraft/spacecraft, nuclear power controllers, fuel controllers, car equipment including car accessories, safety devices, etc.) and whose malfunction or failure may cause loss of human life, bodily injury or serious damage to property ("Specific Applications"), please consult with the ROHM sales representative in advance. Unless otherwise agreed in writing by ROHM in advance, ROHM shall not be in any way responsible or liable for any damages, expenses or losses incurred by you or third parties arising from the use of any ROHM's Products for Specific Applications.

(Note1) Medical Equipment Classification of the Specific Applications

JAPAN	USA	EU	CHINA
CLASS III	CLASS III	CLASS II b	CLASS III
CLASS IV		CLASS III	

- ROHM designs and manufactures its Products subject to strict quality control system. However, semiconductor products can fail or malfunction at a certain rate. Please be sure to implement, at your own responsibilities, adequate safety measures including but not limited to fail-safe design against the physical injury, damage to any property, which a failure or malfunction of our Products may cause. The following are examples of safety measures:
  - Installation of protection circuits or other protective devices to improve system safety
  - Installation of redundant circuits to reduce the impact of single or multiple circuit failure
- Our Products are designed and manufactured for use under standard conditions and not under any special or extraordinary environments or conditions, as exemplified below. Accordingly, ROHM shall not be in any way responsible or liable for any damages, expenses or losses arising from the use of any ROHM's Products under any special or extraordinary environments or conditions. If you intend to use our Products under any special or extraordinary environments or conditions (as exemplified below), your independent verification and confirmation of product performance, reliability, etc. prior to use, must be necessary:
  - Use of our Products in any types of liquid, including water, oils, chemicals, and organic solvents
  - Use of our Products outdoors or in places where the Products are exposed to direct sunlight or dust
  - Use of our Products in places where the Products are exposed to sea wind or corrosive gases, including Cl<sub>2</sub>, H<sub>2</sub>S, NH<sub>3</sub>, SO<sub>2</sub>, and NO<sub>2</sub>
  - Use of our Products in places where the Products are exposed to static electricity or electromagnetic waves
  - Use of our Products in proximity to heat-producing components, plastic cords, or other flammable items
  - Sealing or coating our Products with resin or other coating materials
  - Use of our Products without cleaning residue of flux (even if you use no-clean type fluxes, cleaning residue of flux is recommended); or Washing our Products by using water or water-soluble cleaning agents for cleaning residue after soldering
  - Use of the Products in places subject to dew condensation
- The Products are not subject to radiation-proof design.
- Please verify and confirm characteristics of the final or mounted products in using the Products.
- In particular, if a transient load (a large amount of load applied in a short period of time, such as pulse. is applied, confirmation of performance characteristics after on-board mounting is strongly recommended. Avoid applying power exceeding normal rated power; exceeding the power rating under steady-state loading condition may negatively affect product performance and reliability.
- De-rate Power Dissipation depending on ambient temperature. When used in sealed area, confirm that it is the use in the range that does not exceed the maximum junction temperature.
- Confirm that operation temperature is within the specified range described in the product specification.
- ROHM shall not be in any way responsible or liable for failure induced under deviant condition from what is defined in this document.

## Precaution for Mounting / Circuit board design

- When a highly active halogenous (chlorine, bromine, etc.) flux is used, the residue of flux may negatively affect product performance and reliability.
- In principle, the reflow soldering method must be used on a surface-mount products, the flow soldering method must be used on a through hole mount products. If the flow soldering method is preferred on a surface-mount products, please consult with the ROHM representative in advance.

For details, please refer to ROHM Mounting specification

### Precautions Regarding Application Examples and External Circuits

1. If change is made to the constant of an external circuit, please allow a sufficient margin considering variations of the characteristics of the Products and external components, including transient characteristics, as well as static characteristics.
2. You agree that application notes, reference designs, and associated data and information contained in this document are presented only as guidance for Products use. Therefore, in case you use such information, you are solely responsible for it and you must exercise your own independent verification and judgment in the use of such information contained in this document. ROHM shall not be in any way responsible or liable for any damages, expenses or losses incurred by you or third parties arising from the use of such information.

### Precaution for Electrostatic

This Product is electrostatic sensitive product, which may be damaged due to electrostatic discharge. Please take proper caution in your manufacturing process and storage so that voltage exceeding the Products maximum rating will not be applied to Products. Please take special care under dry condition (e.g. Grounding of human body / equipment / solder iron, isolation from charged objects, setting of Ionizer, friction prevention and temperature / humidity control).

### Precaution for Storage / Transportation

1. Product performance and soldered connections may deteriorate if the Products are stored in the places where:
  - [a] the Products are exposed to sea winds or corrosive gases, including Cl<sub>2</sub>, H<sub>2</sub>S, NH<sub>3</sub>, SO<sub>2</sub>, and NO<sub>2</sub>
  - [b] the temperature or humidity exceeds those recommended by ROHM
  - [c] the Products are exposed to direct sunshine or condensation
  - [d] the Products are exposed to high Electrostatic
2. Even under ROHM recommended storage condition, solderability of products out of recommended storage time period may be degraded. It is strongly recommended to confirm solderability before using Products of which storage time is exceeding the recommended storage time period.
3. Store / transport cartons in the correct direction, which is indicated on a carton with a symbol. Otherwise bent leads may occur due to excessive stress applied when dropping of a carton.
4. Use Products within the specified time after opening a humidity barrier bag. Baking is required before using Products of which storage time is exceeding the recommended storage time period.

### Precaution for Product Label

A two-dimensional barcode printed on ROHM Products label is for ROHM's internal use only.

### Precaution for Disposition

When disposing Products please dispose them properly using an authorized industry waste company.

### Precaution for Foreign Exchange and Foreign Trade act

Since concerned goods might be fallen under listed items of export control prescribed by Foreign exchange and Foreign trade act, please consult with ROHM in case of export.

### Precaution Regarding Intellectual Property Rights

1. All information and data including but not limited to application example contained in this document is for reference only. ROHM does not warrant that foregoing information or data will not infringe any intellectual property rights or any other rights of any third party regarding such information or data.
2. ROHM shall not have any obligations where the claims, actions or demands arising from the combination of the Products with other articles such as components, circuits, systems or external equipment (including software).
3. No license, expressly or implied, is granted hereby under any intellectual property rights or other rights of ROHM or any third parties with respect to the Products or the information contained in this document. Provided, however, that ROHM will not assert its intellectual property rights or other rights against you or your customers to the extent necessary to manufacture or sell products containing the Products, subject to the terms and conditions herein.

### Other Precaution

1. This document may not be reprinted or reproduced, in whole or in part, without prior written consent of ROHM.
2. The Products may not be disassembled, converted, modified, reproduced or otherwise changed without prior written consent of ROHM.
3. In no event shall you use in any way whatsoever the Products and the related technical information contained in the Products or this document for any military purposes, including but not limited to, the development of mass-destruction weapons.
4. The proper names of companies or products described in this document are trademarks or registered trademarks of ROHM, its affiliated companies or third parties.

## X-ON Electronics

Largest Supplier of Electrical and Electronic Components

*Click to view similar products for [Board Mount Hall Effect/Magnetic Sensors](#) category:*

*Click to view products by [ROHM](#) manufacturer:*

Other Similar products are found below :

[HGPRDT005A](#) [AH277AZ4-AG1](#) [AV-10448](#) [SS41C](#) [AH1894-Z-7](#) [TLE4917](#) [TLE4946-1L](#) [50017859-003](#) [TY-13101](#) [TLE4976L](#)  
[A1308KUA-1-T](#) [SS85CA](#) [BU52002GUL-E2](#) [BU52003GUL-E2](#) [AH277AZ4-BG1](#) [TLE49614MXTSA1](#) [AH3382-P-B](#) [AH3377-P-B](#)  
[AH211Z4-AG1](#) [AH3360-FT4-7](#) [TLE4941-1](#) [SS460S-100SAMPLE](#) [AH374-P-A](#) [TLE49595UFXHALA1](#) [SS460P-T2](#) [AH1913-W-7](#) [AH3373-](#)  
[P-B](#) [TLE9852QXXUMA1](#) [MA732GQ-Z](#) [MA330GQ-Z](#) [TLE49421CHAMA2](#) [AH1903-FA-EVM](#) [AH8502-FDC-EVM](#) [TLE4998S3XALA1](#)  
[TLE5011FUMA1](#) [TLE5027CE6747HAMA1](#) [TLE5109A16E1210XUMA1](#) [TLI4966GHTSA1](#) [TLI4906KHTSA1](#) [MA710GQ-P](#) [S-](#)  
[57K1NBL2A-M3T2U](#) [S-57P1NBL9S-M3T4U](#) [S-576ZNL2B-L3T2U](#) [S-576ZNL2B-A6T8U](#) [S-57P1NBL0S-M3T4U](#) [S-57A1NSL1A-M3T2U](#)  
[S-57K1RBL1A-M3T2U](#) [S-57P1NBH9S-M3T4U](#) [S-57P1NBH0S-M3T4U](#) [S-57A1NSH1A-M3T2U](#)