

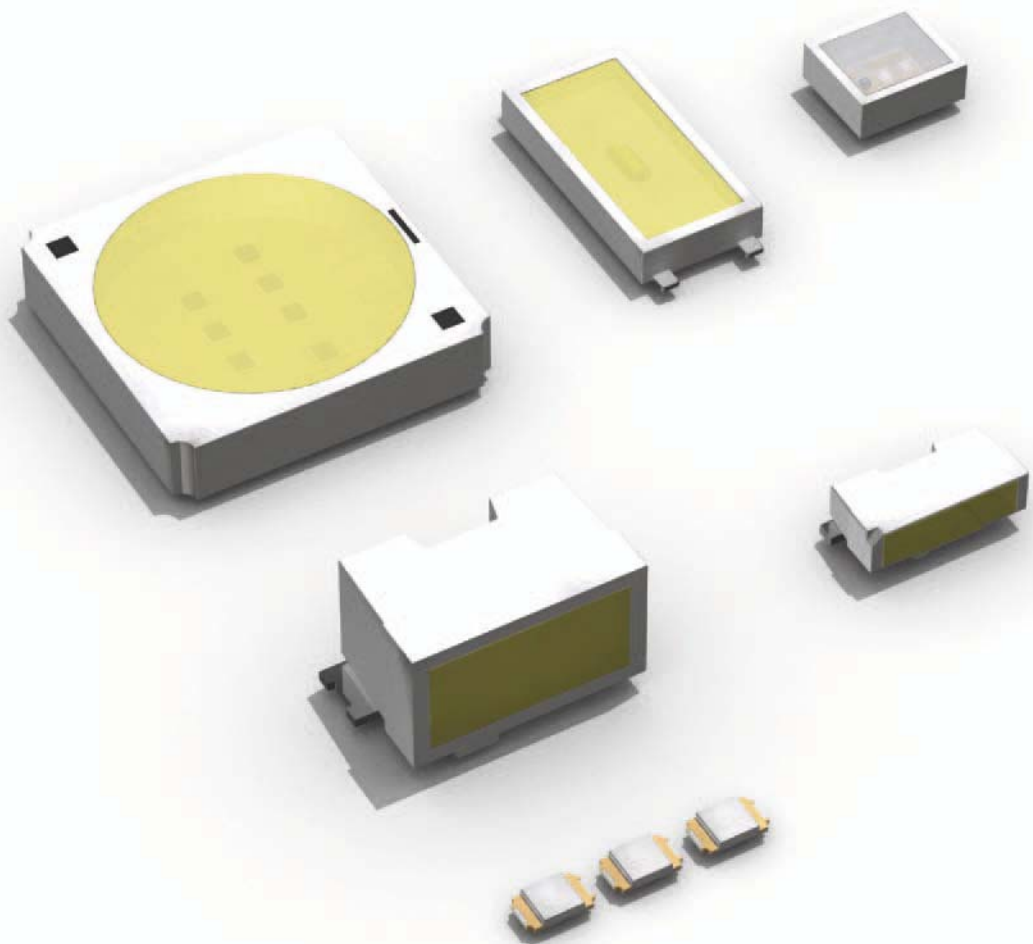

2012

New Products Catalog

Opto Electronics



# LED New Products

LED New Products

ROHM Co.,Ltd.



## Contents

〈SSML Series〉	PSL01 series	2
〈PSML Series〉	SMLK□ series	4
〈PSML3 Series〉	PSL02 series	6
〈PICOLED™-RGB Series〉	SMLP3 series / MSL02 series	8
〈GC-RGB Series〉	MSL0301 / MSL0401RGB	10
〈SRGB-Black〉	SMLV36RGB1B	11
〈SRGB-S Series〉	MSL01 series	12
〈Lamp〉	SLD430 / SLI-430 series	14
	SLI-565 series	15

PICOLED™ is ROHM's pending trademark. EXCELED™ is ROHM's pending trademark.

# SSML Series

High Heat Resistance  
High Power White LEDs

**PSL0101 series / PSL0102 series**



Color Type **WB**

## High Reliability

Achieves operation temperature of 130°C

A high thermal resistance material is used to ensure stable performance at high ambient temperatures.

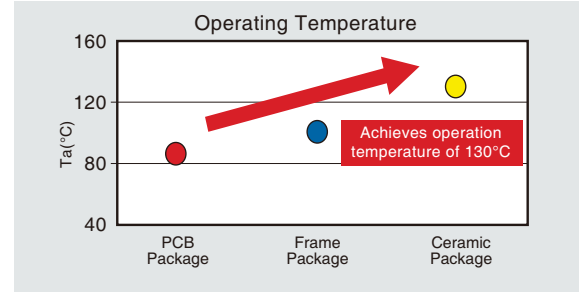

## High reliability product from the harsh environment of Out-side Lighting

The product is made of Au plating with Ceramic package, non Sulfur influence and keeping Luminous intensity.

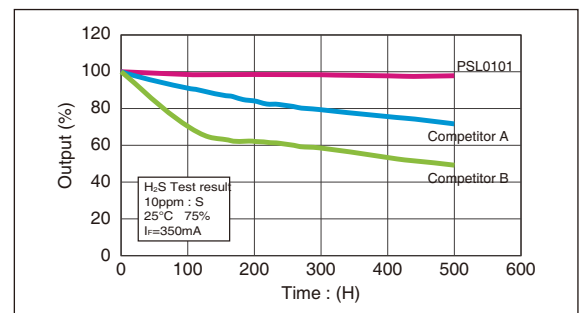

## High Heat radiation

High Power 1W white LED

High efficiency is maintained (105 lm/W), even during continuous, large-current operation (350mA).

This product is keeping output intensity from high current condition due to our original packaging technology.

Keeping Luminous intensity less than approximately 10% after 300s turn-on.

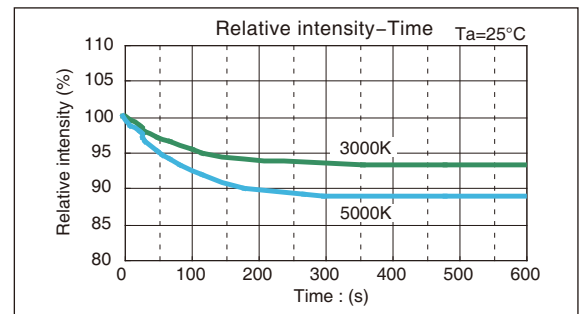

## Specifications

**Under Development**

Part No.	Chip Structure	Emitted Color	Average Color Rendering Index (Ra)	Absolute Maximum Ratings (Ta=25°C)					Electrical and Optical Characteristics (Ta=25°C)															
				Power Dissipation Pd(W)	Forward Current If(mA)	Peak Forward Current IfP(mA)	Operating Temperature Topr(°C)	Storage Temperature Tstg(°C)	Forward Voltage Vf Typ.(V)	If(mA)	Chromaticity Coordinates (x, y)	If(mA)	Luminous Flux φv Typ. (lm)	If(mA)										
<input type="checkbox"/> PSL0101WBEA	InGaN	White (5,000K)	65	1.95	500*1	1,000*2	-40 to +130	-40 to +130	3.3	350	(0.345, 0.352)	350	95	350										
<input type="checkbox"/> PSL0101WBEB			80										85											
<input type="checkbox"/> PSL0101WBEC			90										70											
<input type="checkbox"/> PSL0101WBED			75										95											
<input type="checkbox"/> PSL0101WBFA		White (3,000K)	65										0.78		200*1	400*2	-40 to +130	-40 to +130	3.3	120	(0.437, 0.404)	120	90	120
<input type="checkbox"/> PSL0101WBFB			80																				80	
<input type="checkbox"/> PSL0101WBFC			90																				65	
<input type="checkbox"/> PSL0101WBFD			74																				85	
<input type="checkbox"/> PSL0102WBEA	InGaN	White (5,000K)	65	0.78	200*1	400*2	-40 to +130	-40 to +130	3.3	120	(0.345, 0.352)	120		44									120	
<input type="checkbox"/> PSL0102WBEB			80											38										
<input type="checkbox"/> PSL0102WBEC			90											30										
<input type="checkbox"/> PSL0102WBED			75											42										

\*1: Mounting conditions must be carefully considered. \*2: Duty ≤ 1/10, pulse width 10ms Max

### Chromaticity Diagram

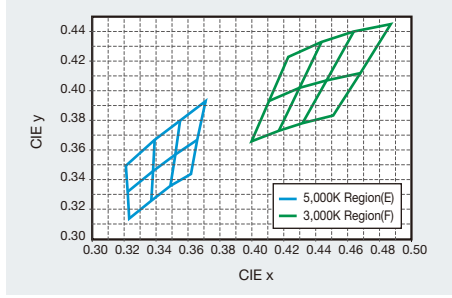

### Spectrum Data

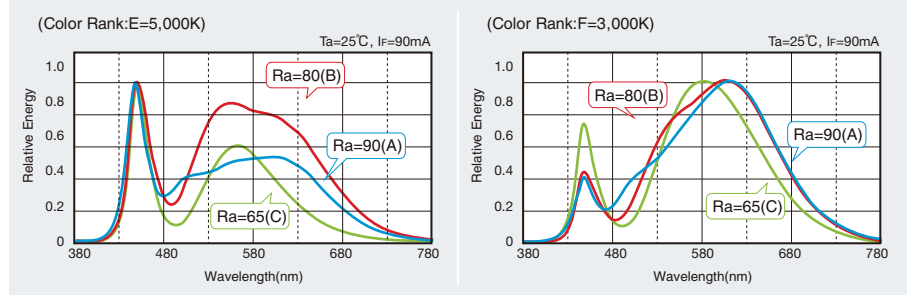

### Dimensions

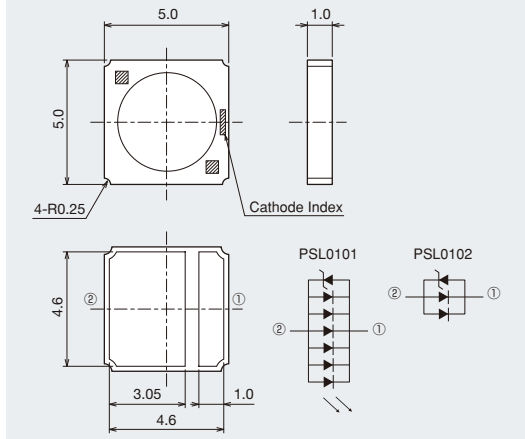

### Recommended Solder Pattern

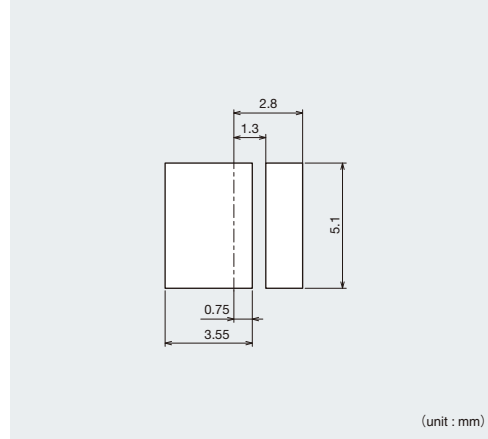

### Viewing Angle

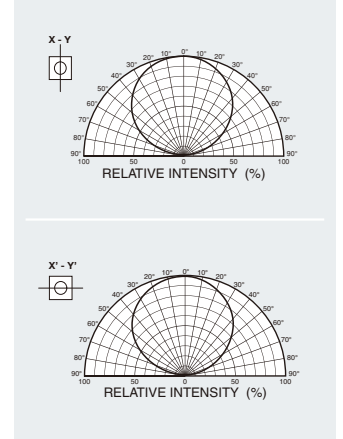

### Electrical Characteristics Curves

#### Forward Voltage - Forward Current

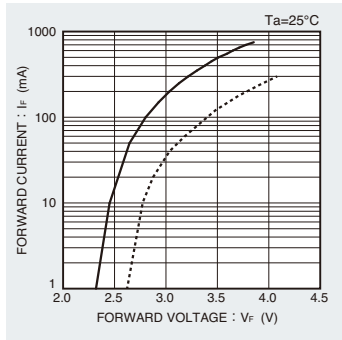

- PSL0101WBEA
- PSL0101WBEB
- PSL0101WBEC
- PSL0101WBED
- PSL0101WBFA
- PSL0101WBFB
- PSL0101WBFC
- PSL0101WBFD
- PSL0102WBEA
- PSL0102WBEB
- PSL0102WBEC
- PSL0102WBED

#### Atmosphere Temperature - Relative Luminous Intensity

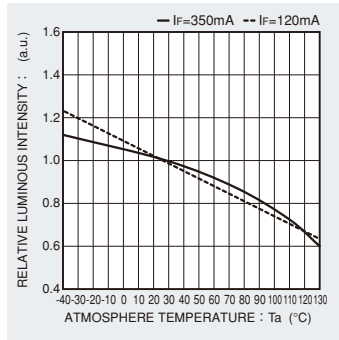

- PSL0101WBEA
- PSL0101WBEB
- PSL0101WBEC
- PSL0101WBED
- PSL0101WBFA
- PSL0101WBFB
- PSL0101WBFC
- PSL0101WBFD
- PSL0102WBEA
- PSL0102WBEB
- PSL0102WBEC
- PSL0102WBED

#### Derating

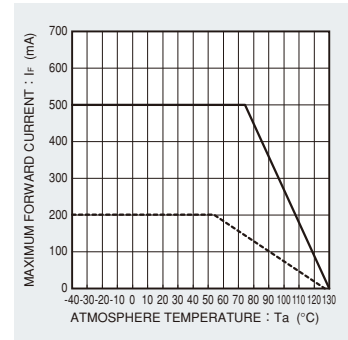

- PSL0101WBEA
- PSL0101WBEB
- PSL0101WBEC
- PSL0101WBED
- PSL0101WBFA
- PSL0101WBFB
- PSL0101WBFC
- PSL0101WBFD
- PSL0102WBEA
- PSL0102WBEB
- PSL0102WBEC
- PSL0102WBED

#### Forward Current-Relative Luminous Flux (PSL0101 series)

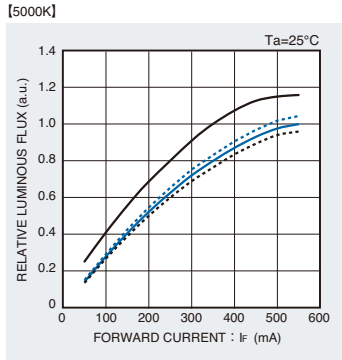

- PSL0101WBEA
- PSL0101WBEB
- PSL0101WBEC
- PSL0101WBED

#### Forward Current-Relative Luminous Flux (PSL0102 series)

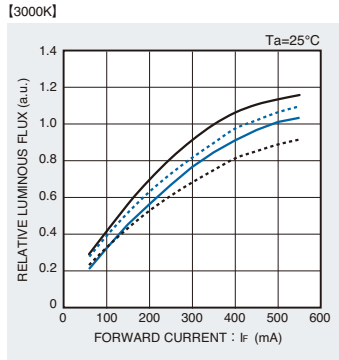

- PSL0101WBFA
- PSL0101WBFB
- PSL0101WBFC
- PSL0101WBFD

#### Forward Current-Relative Luminous Flux (PSL0102 series)

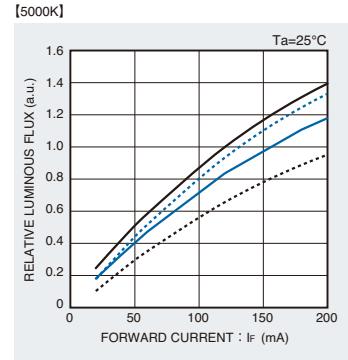

- PSL0102WBEA
- PSL0102WBEB
- PSL0102WBEC
- PSL0102WBED

# PSML Series

High Luminous Intensity,  
High Heat Dissipation LEDs

SMLKA □ / SMLK1 □ / SMLK2 □

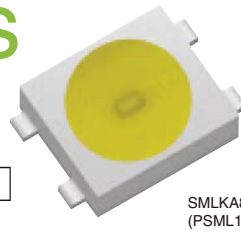

SMLKA8  
(PSML1)

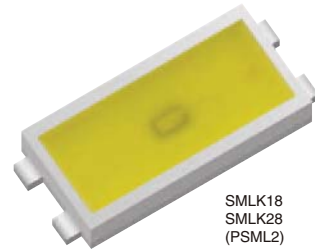

SMLK18  
SMLK28  
(PSML2)

Color Type WB

## Flat-frame high heat dissipation package

ROHM utilizes a Cu frame package featuring high heat conductivity, with exposed backside for improved thermal dissipation. As a result, thermal resistance is increased by 25%, enabling high current flow and greater luminosity.

### Advantages of High Heat Dissipation

- Reduced temperature dependency (deterioration in luminous intensity and color)
- Longer life
- Higher operating temperature range
- Excellent derating characteristics

## Industry-leading brightness

Superior heat dissipation characteristics ensure high brightness, even in the medium current range (50-150mA).

(45) Lower junction temperatures result in excellent derating characteristics, extending the operating temperature range. High reliability is also ensured.

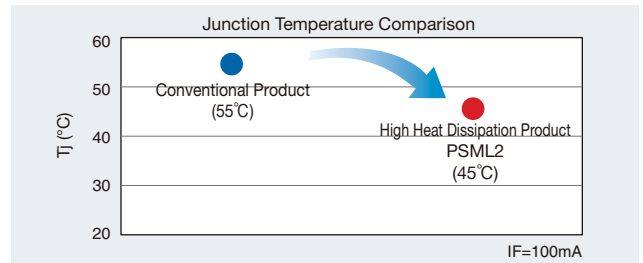
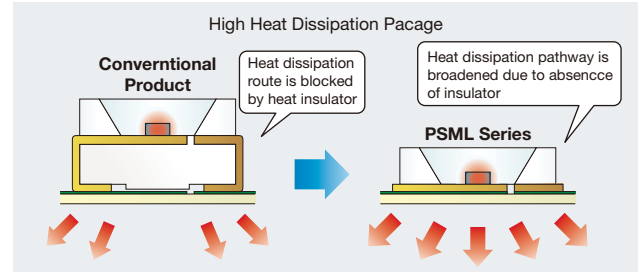

## SMLKA8(PSML1)

### Specifications

Under Development

Part No.	Chip Structure	Emitted Color	Absolute Maximum Ratings (Ta=25°C)						Electrical and Optical Characteristics (Ta=25°C)										
			Power Dissipation Pd(mW)	Forward Current If(mA)	Peak Forward Current Ifp(mA)	Reverse Voltage VR(V)	Operating Temperature Topr(°C)	Storage Temperature Tstg(°C)	Forward Voltage VF Typ.(V)	IF(mA)	Reverse Current IR Max.(μA)	VR(V)	Chromaticity Coordinates (x, y)	IF(mA)	Luminous Intensity Iv Min.(cd)	Typ.(cd)	Luminous Flux Φv Typ.(lm)	IF(mA)	
□ SMLKA8WBJCW	InGaN	White	675	150*1	230*2	5	-40 to +100	-40 to +100	3.9	90	10	5	(0.30, 0.28)	90	4.0	5.9	90	(20)	90

\* 1: Mounting conditions must be carefully considered \* 2: Duty ≤ 1/10, 10ms

### Dimensions

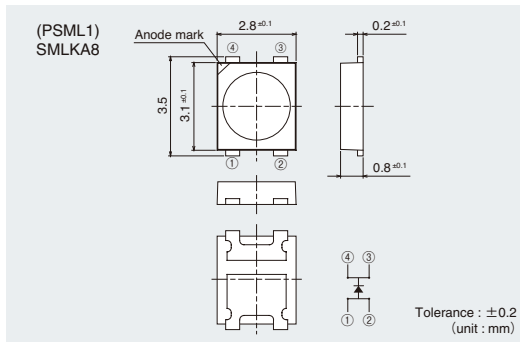

### Recommended Solder Pattern

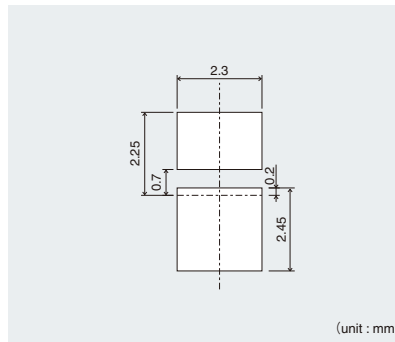

### Viewing Angle

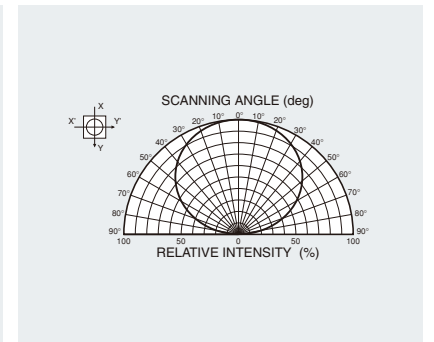

## Electrical Characteristics Curves

### Forward Voltage-Forward Current

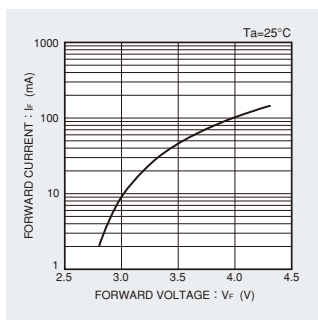

■ □ SMLKA8WBJCW

### Atmosphere Temperature-Relative Luminous Intensity

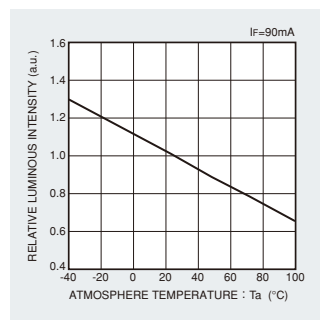

■ □ SMLKA8WBJCW

### Forward Current-Relative Luminous Intensity

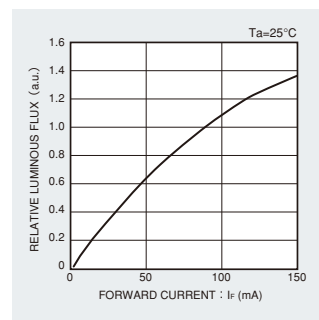

■ □ SMLKA8WBJCW

### Derating

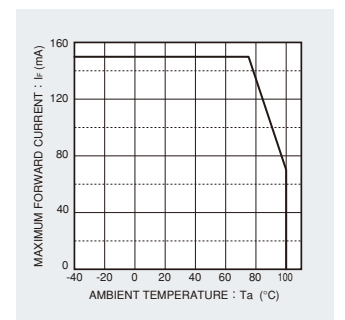

■ □ SMLKA8WBJCW

# SMLK18/SMLK28(PSML2)

## Specifications

Under Development

Part No.	Chip Structure	Emitted Color	Absolute Maximum Ratings (Ta=25°C)					Electrical and Optical Characteristics (Ta=25°C)																		
			Power Dissipation Pd(mW)	Forward Current If(mA)	Peak Forward Current Ifp(mA)	Reverse Voltage Vr(V)	Operating Temperature Topr(°C)	Storage Temperature Tstg(°C)	Forward Voltage Vf Typ.(V)	Reverse Current Ir Max.(μA)	Reverse Current Ir Vr(V)	Chromaticity Coordinates (x, y)	Luminous Intensity Iv If(mA)	Luminous Intensity Iv Typ.(cd)	Luminous Flux Φv Typ.(lm)	Luminous Flux Φv If(mA)										
<input type="checkbox"/> SMLK18WBJAW	InGaN	White (5000K)	675	150	230*	5	-40 to +100	-40 to +100	3.9	90	10	5	(0.345, 0.351)	90	4.8	90	(17)									
<input type="checkbox"/> SMLK18WBJBW		White (3000K)											(0.44, 0.40)					3.3	4.5	(16)						
<input type="checkbox"/> SMLK18WBJCW		White (3000K)											(0.30, 0.28)								5.9	90	(21)			
<input type="checkbox"/> SMLK18WBJDW		White											(0.34, 0.34)											4.8	6.0	(22)
<input type="checkbox"/> SMLK28WBJCW													(0.30, 0.28)													

\* Duty 1/10 ≤ 10ms ( ): Reference

## Dimensions

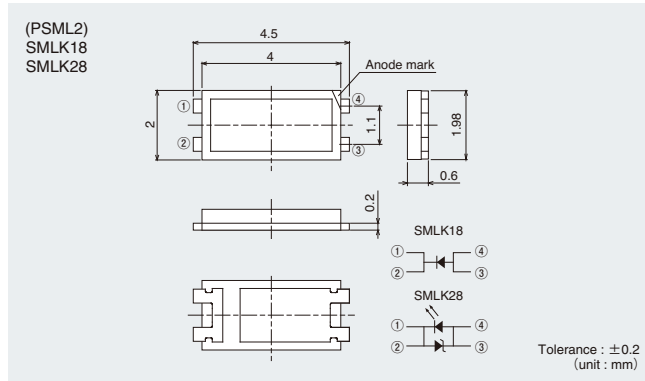

## Recommended Solder Pattern

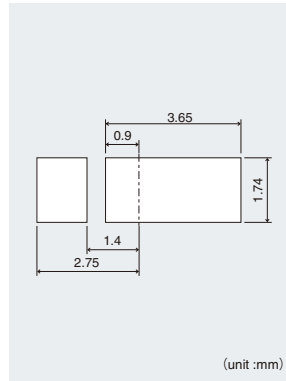

## Viewing Angle

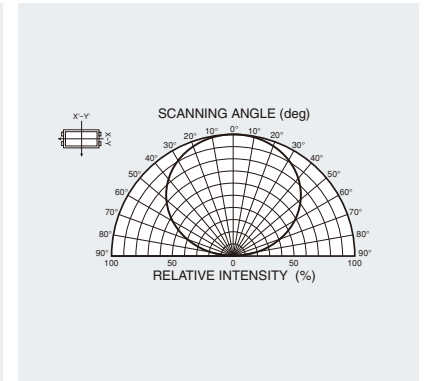

## Chromaticity Diagram

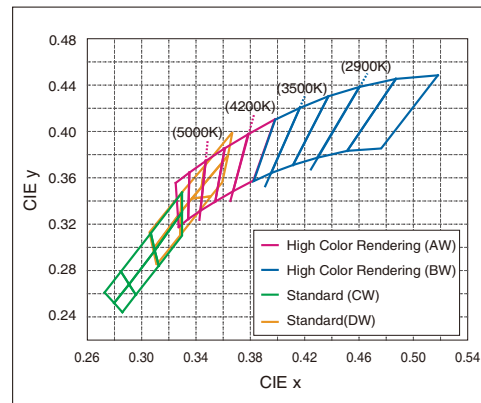

## Electrical Characteristics Curves

### Forward Voltage-Forward Current

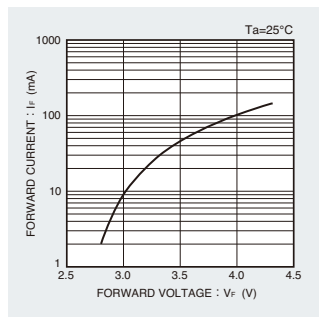

### Atmosphere Temperature-Relative Luminous Intensity

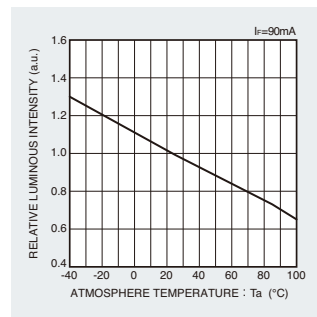

### Forward Current-Relative Luminous Intensity

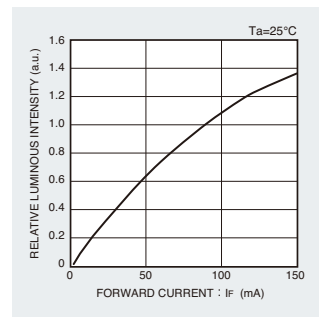

### Derating

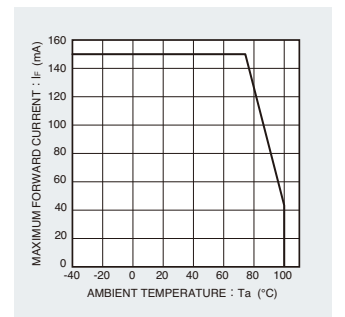

- SMLK18WBJAW
- SMLK18WBJBW
- SMLK18WBJCW
- SMLK18WBJDW
- SMLK28WBJCW

- SMLK18WBJAW
- SMLK18WBJBW
- SMLK18WBJCW
- SMLK18WBJDW
- SMLK28WBJCW

- SMLK18WBJAW
- SMLK18WBJBW
- SMLK18WBJCW
- SMLK18WBJDW
- SMLK28WBJCW

- SMLK18WBJAW
- SMLK18WBJBW
- SMLK18WBJCW
- SMLK18WBJDW
- SMLK28WBJCW

# PSML3 Series

High Brightness  
High Heat Dissipation White LEDs  
**PSL02 series**

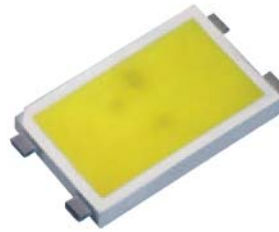

Color Type WB

## ROHM's Original Heat Dissipation Package

Optimized for both backlighting and illumination applications.  
A new flat frame package type featuring high heat dissipation and high brightness is now available.  
Optical output is increased with 5630 size package which is larger than PSML2 (4520).

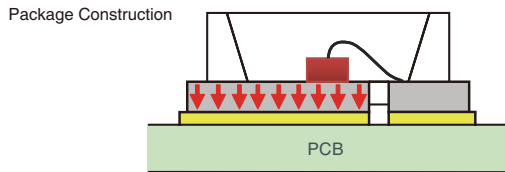

Flat frame construction enables direct heat dissipation to the board

Forward Current vs. Luminous Flux

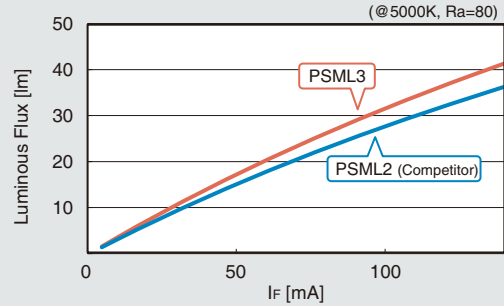

Luminous flux is improved in the high-current region compared with conventional products. In addition, heat generation is reduced even at high output.

## Specifications

Part No.	Chip Structure	Emitted Color	Color Rendering Index (Ra)	Absolute Maximum Ratings (Ta=25°C)						Electrical and Optical Characteristics (Ta=25°C)											
				Power Dissipation Pd(mW)	Forward Current If(mA)	Peak Forward Current Ifp(mA)	Reverse Voltage Vr(V)	Operating Temperature Topr(°C)	Storage Temperature Tstg(°C)	Forward Voltage Vf(V)	Reverse Current Ir(μA)	Max. Vr(V)	Chromaticity Coordinates (x,y)	Luminous Intensity Iv		Luminous Flux Φv					
□ PSL0205WBEB	InGaN	White (5000K)	80	525	150	300*2	5	-40 to +100	-40 to +100	3.1	60	10	5	(0.345,0.350)	60	60	—	19	60		
□ PSL0205WBEC			90																	4.2	16
□ PSL0205WBED			70																	5.5	21
□ PSL0205WBFB		80	4.5																	17	
□ PSL0205WBFC		90	3.8																	14	
□ PSL0205WBFD		70	4.8																	18	
□ PSL0212W50B	InGaN	White (5000K)	83	540	150	300*2	—	-40 to +100	-40 to +100	3.15	120	—	—	(0.345,0.350)	120	120	—	(36)	41		
□ PSL0212W50C			93																	(30.3)	37
□ PSL0212W50D			75																	(36)	44
□ PSL0212W30B		80	(30.3)																	37	
□ PSL0212W30C		90	(25.5)																	32	
□ PSL0212W30D		74	(30.3)																	40	

\*1:Ra=over 95 is available. \*2:Duty ≤ 1/10, pulse width 10ms Max.

## Chromaticity Diagram

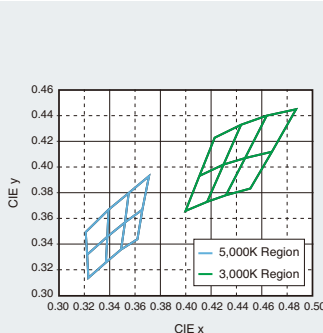

## Dimensions

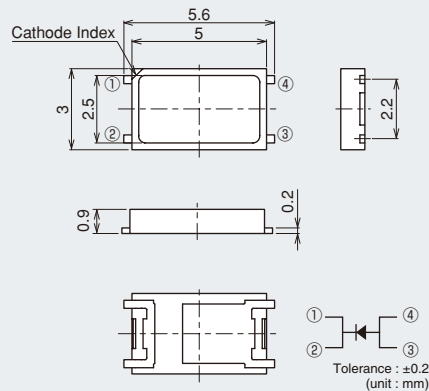

## Recommended Solder Pattern

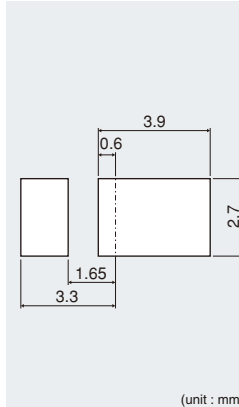

## Viewing Angle

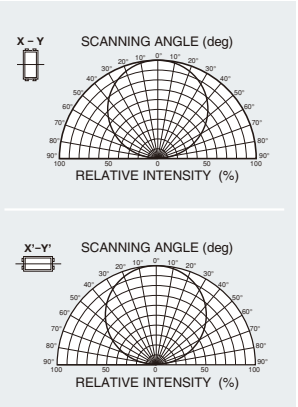



## Electrical Characteristics Curves

### Forward Voltage-Forward Current

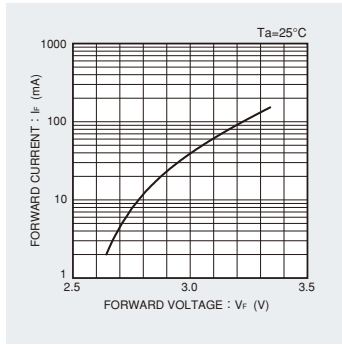

- PSL0205WBEB
- PSL0205WBEC
- PSL0205WBED
- PSL0205WBFB
- PSL0205WBFC
- PSL0205WBFD

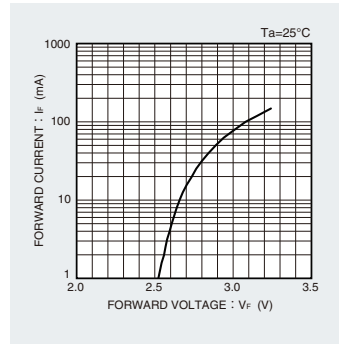

- PSL0212W50B
- PSL0212W50C
- PSL0212W50D
- PSL0212W30B
- PSL0212W30C
- PSL0212W30D

### Atmosphere Temperature-Relative Luminous Intensity

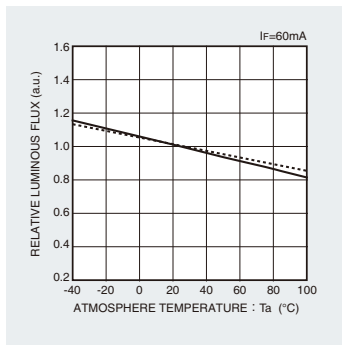

- PSL0205WBEB
- PSL0205WBFB

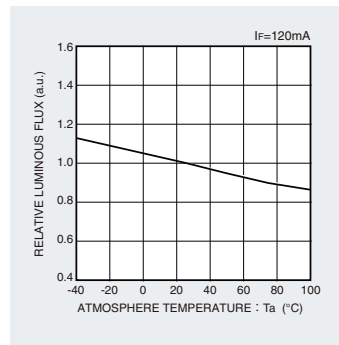

- PSL0212W50B
- PSL0212W50C
- PSL0212W50D
- PSL0212W30B
- PSL0212W30C
- PSL0212W30D

### Forward Current-Relative Luminous Intensity

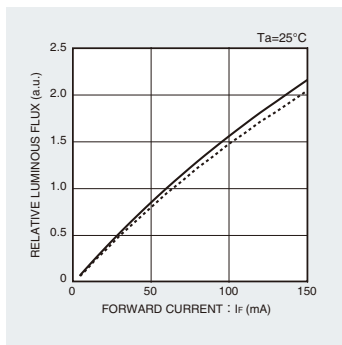

- PSL0205WBEB
- PSL0205WBFB

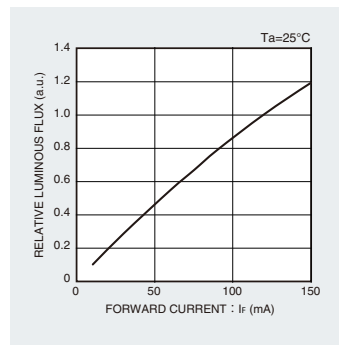

- PSL0212W50B
- PSL0212W50C
- PSL0212W50D
- PSL0212W30B
- PSL0212W30C
- PSL0212W30D

### Derating

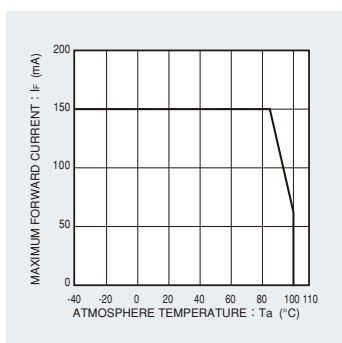

- PSL0205WBEB
- PSL0205WBEC
- PSL0205WBED
- PSL0205WBFB
- PSL0205WBFC
- PSL0205WBFD

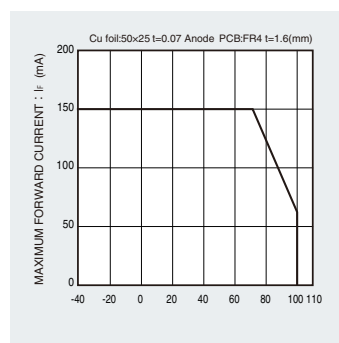

- PSL0212W50B
- PSL0212W50C
- PSL0212W50D
- PSL0212W30B
- PSL0212W30C
- PSL0212W30D

# PICOLED™-RGB Series

High Brightness, and Side-view RGB LED in Debut

**SMLP34RGB2W / SMLP36RGB2W / MSL0201RGB**

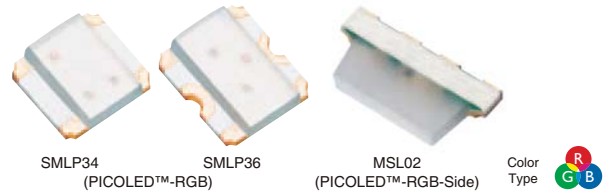

## Thin package, side view RGB

Side view type now appeared in the line-up of small package 3 in 1 LED. Height only 0.43mm, contribute space saving for mobile applications.



## Ultra small and high brightness RGB1 LEDs

The luminous intensity improved drastically up keeping small size package by developing high luminance LED die.

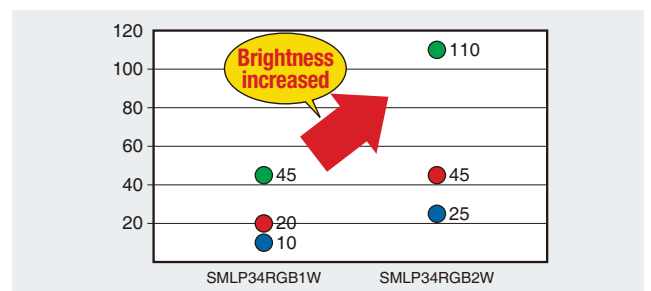

## Specifications

Part No.	Chip Structure	Emitted Color	Absolute Maximum Ratings (Ta=25°C)					Electrical and Optical Characteristics (Ta=25°C)											
			Forward Current I <sub>F</sub> (mA)	Peak Forward Current I <sub>FP</sub> (mA)	Reverse Voltage V <sub>R</sub> (V)	Operating Temperature T <sub>opr</sub> (°C)	Storage Temperature T <sub>stg</sub> (°C)	Forward Voltage V <sub>F</sub> Typ.(V)	I <sub>F</sub> (mA)	Reverse Current I <sub>R</sub> Max.(μA)	V <sub>R</sub> (V)	Dominant Wavelength λ <sub>D</sub> (nm)			Luminous Intensity I <sub>v</sub> (mcd)				
■ <b>MSL0201RGB</b> (Side-View)	AlGaInP	Red											618	624	630		11	25	
	InGaN	Green	20	100*1	5	-40 to +85	-40 to +100	3.0	5	100	5		519	527	536	5	56	90	5
		Blue						2.9					466	470	476		11	22	
■ <b>SMLP34RGB2W</b> (4 terminals)	AlGaInP	Red											619	624	629		14	35	
	InGaN	Green	20	100*1	5	-40 to +85	-40 to +100	3.3	5	10	5		520	527	535	5	56	110	5
		Blue						3.2					465	470	475		28	45	
■ <b>SMLP36RGB2W</b> (6 terminals)	AlGaInP	Red											619	624	629		14	35	
	InGaN	Green	20	100*1	5	-40 to +85	-40 to +100	3.3	5	10	5		520	527	535	5	56	110	5
		Blue						3.2					465	470	475		28	45	

\*1: Duty ≤ 1/20, 1kHz \*2: Reference

## Dimensions

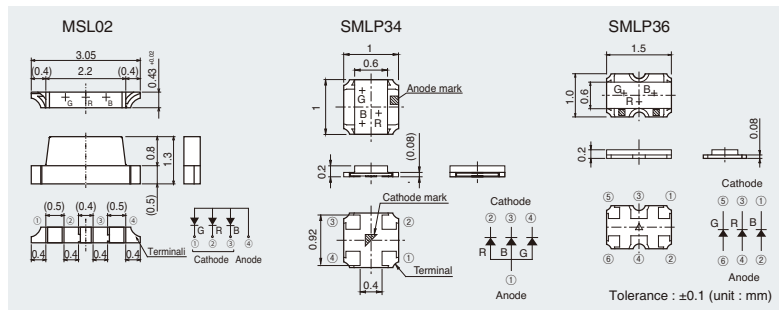

## Recommended Solder Pattern

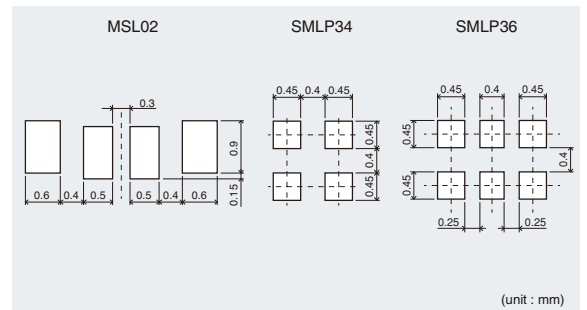

## Viewing Angle

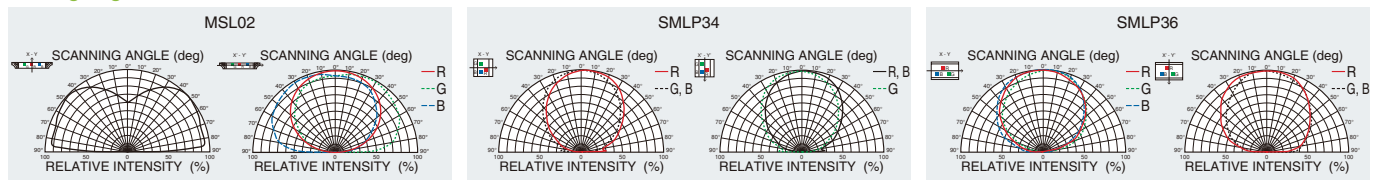

\* PICOLED™ is ROHM's pending trademark.

## Electrical Characteristics Curves

### Forward Voltage-Forward Current

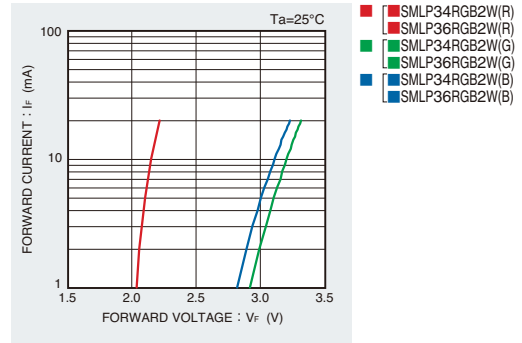
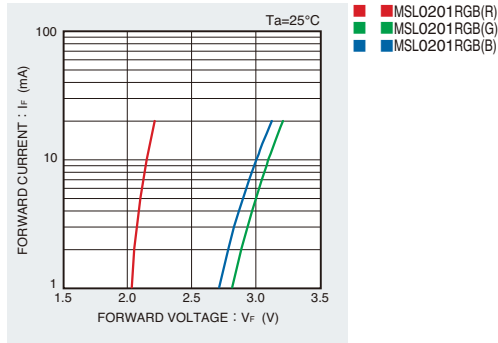

### Atmosphere Temperature-Relative Luminous Intensity

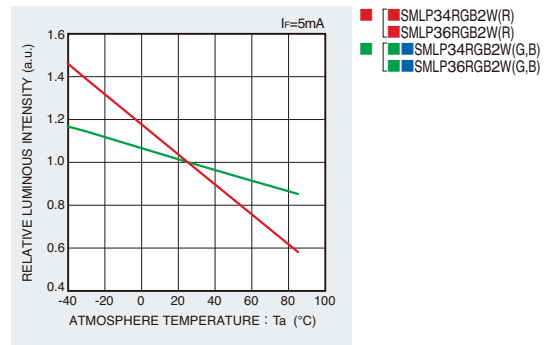
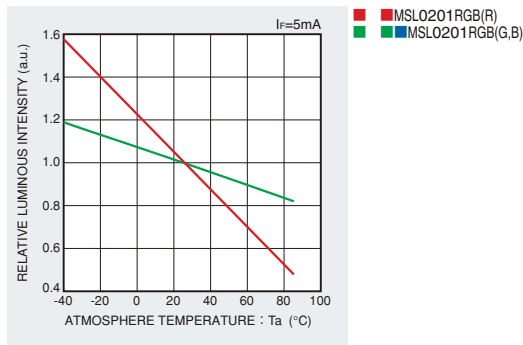

### Forward Current-Relative Luminous Intensity

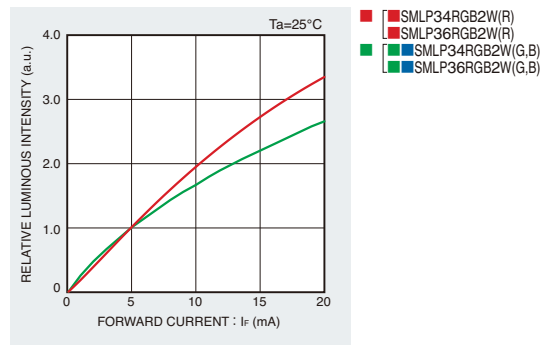
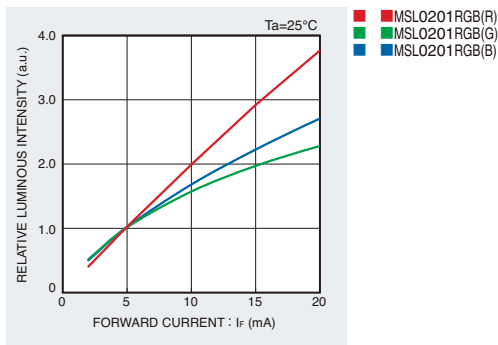

### Derating

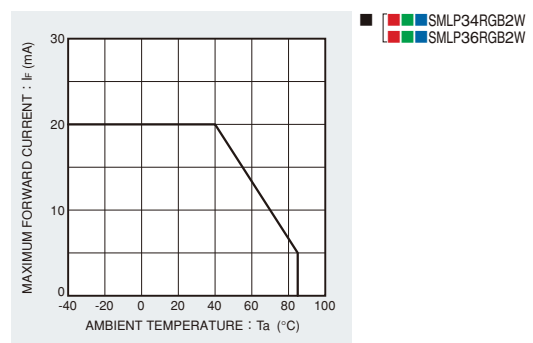
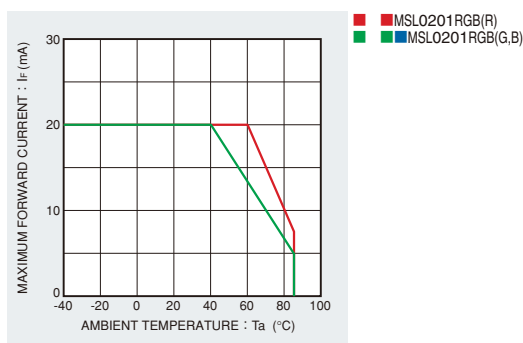

# GC-RGB Series

Compact High Brightness RGB LEDs with Reflector

**MSL0301RGB / MSL0401RGB**

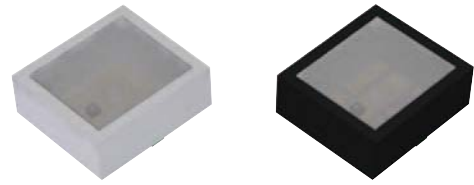

## High brightness with excellent color mixing

Reflector design increases luminosity at the front while minimizing light leakage from the sides. In addition, die miniaturization technology makes it possible to place the dies closer together for excellent color mixing characteristics.

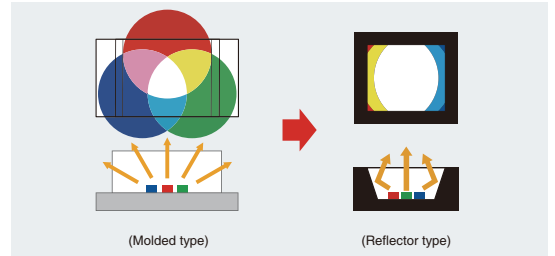

## Industry's smallest mounting area

ROHM's 1816-size reflector-type RGB is the smallest in its class, reducing mounting area considerably. The lineup includes white/black reflector models in 4- or 6-pin configurations for broad applicability.

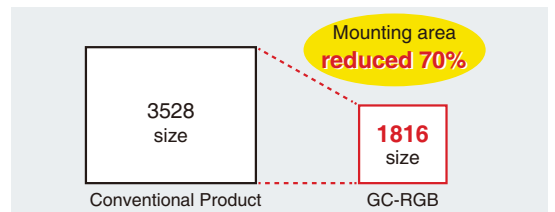

## Specifications

Part No.	Chip Structure	Emitted Color	Absolute Maximum Ratings (Ta=25°C)						Electrical and Optical Characteristics (Ta=25°C)									
			Power Dissipation Pd(mW) <sup>*1</sup>	Forward Current If(mA)	Peak Forward Current Ifp(mA)	Reverse Voltage VR(V)	Operating Temperature Topr(°C)	Storage Temperature Tstg(°C)	Forward Voltage V <sub>F</sub> (V)	Reverse Current I <sub>R</sub> (μA)	Max. VR(V)	Dominant Wavelength λ <sub>D</sub> (nm)			Luminous Iv(mcd)			
■ MSL0301RGBW (4 terminals)	AlGaInP	Red	104	40				2.1	10		618	624	630		220	400		
		Green	120		100 <sup>*2</sup>	5	-40 to +85	-40 to +100	3.4	20	5	519	527	536	20	360	550	
■ MSL0401RGBW (6 terminals)	InGaN	Blue	114	30				3.3	100		464	470	476		90	180		
		Red	104	40				2.1	10		618	624	630		220	220		
■ MSL0301RGBB (4 terminals)	AlGaInP	Green	120		100 <sup>*2</sup>	5	-40 to +85	-40 to +100	3.4	20	5	519	527	536	20	360	280	
		Blue	114	30				3.3	100		464	470	476		90	90		

\*1: Total power dissipation in the case of lighting all 3 colors (reduce by 30% a color)  
\*2: Duty ≤ 1/5, 1kHz (FR4 50mmx50mm substrate, t=1.6mm), copper foil t=0.07mm

## Dimensions

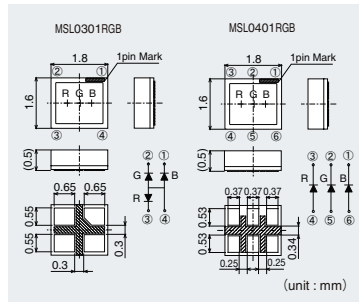

## Recommended Solder Pattern

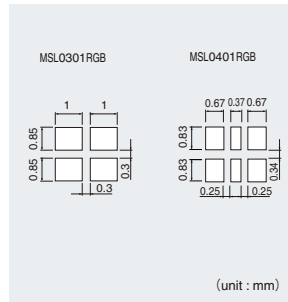

## Viewing Angle

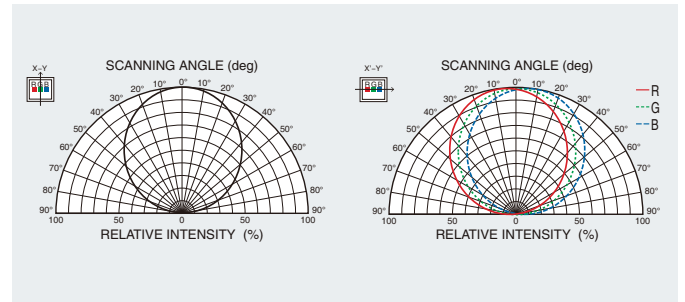

## Electrical Characteristics Curves

### Forward Voltage-Forward Current

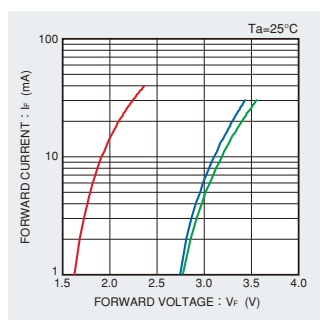

- MSL0301RGBW(R) ■ MSL0301RGBB(R)
- MSL0401RGBW(R) ■ MSL0401RGBB(R)
- MSL0301RGBW(G) ■ MSL0301RGBB(G)
- MSL0401RGBW(G) ■ MSL0401RGBB(G)
- MSL0301RGBW(B) ■ MSL0301RGBB(B)
- MSL0401RGBW(B) ■ MSL0401RGBB(B)

### Atmosphere Temperature-Relative Luminous Intensity

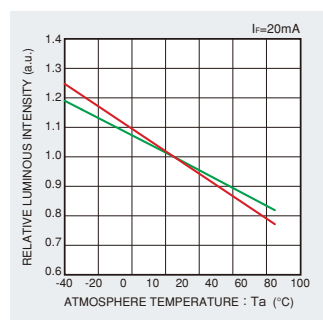

- MSL0301RGBW(R) ■ MSL0301RGBB(R)
- MSL0401RGBW(R) ■ MSL0401RGBB(R)
- MSL0301RGBW(G) ■ MSL0301RGBB(G)
- MSL0401RGBW(G) ■ MSL0401RGBB(G)
- MSL0301RGBW(B) ■ MSL0301RGBB(B)
- MSL0401RGBW(B) ■ MSL0401RGBB(B)

### Forward Current-Relative Luminous Intensity

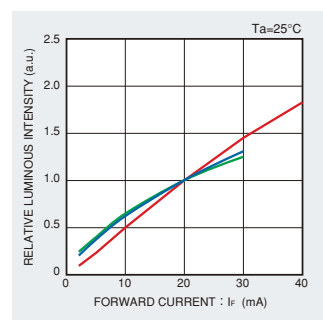

- MSL0301RGBW(R) ■ MSL0301RGBB(R)
- MSL0401RGBW(R) ■ MSL0401RGBB(R)
- MSL0301RGBW(G) ■ MSL0301RGBB(G)
- MSL0401RGBW(G) ■ MSL0401RGBB(G)
- MSL0301RGBW(B) ■ MSL0301RGBB(B)
- MSL0401RGBW(B) ■ MSL0401RGBB(B)

### Derating

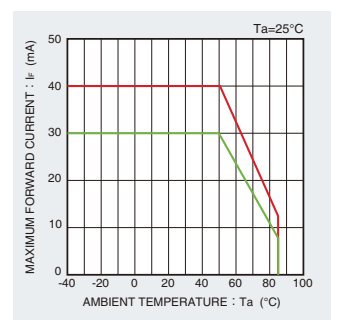

- MSL0301RGBW(R) ■ MSL0301RGBB(R)
- MSL0401RGBW(R) ■ MSL0401RGBB(R)
- MSL0301RGBW(G) ■ MSL0301RGBB(G)
- MSL0401RGBW(G) ■ MSL0401RGBB(G)
- MSL0301RGBW(B) ■ MSL0301RGBB(B)
- MSL0401RGBW(B) ■ MSL0401RGBB(B)

# SRGB-Black

More Vivid RGB LEDs

**SMLV36RGB1B**

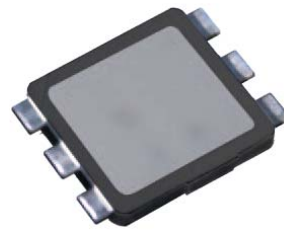

## New package technology offering more vivid emitting color

Making more vivid contrast lowering diffused reflection, by using black reflector.

Also the black package have good effect for display usage.

Making LEDs invisible when it is off, and showing lighted LED more vivid.

### Dot Matrix Example



Using white reflector



Using black reflector

### New package technology producing vivid color

Conventional product



Visibility of light is reduced because of diffused reflection caused by white reflector with large reflectance.

Vivid type SRGB2-Black

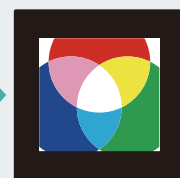

Diffused reflection is lowered by changing the color of reflector into black.



(sectional view)

## Specifications

Part No.	Chip Structure	Emitted Color	Absolute Maximum Ratings (Ta=25°C)						Electrical and Optical Characteristics (Ta=25°C)									
			Power Dissipation Pd(mW)	Forward Current If(mA)	Peak Forward Current Ifp(mA)	Reverse Voltage Vr(V)	Operating Temperature Topr(°C)	Storage Temperature Tstg(°C)	Forward Voltage V <sub>f</sub> (V)	Reverse Current I <sub>r</sub> (μA)	Dominant Wavelength λ <sub>D</sub> (nm)	Luminous Iv(mcd)						
<b>SMLV36RGB1B</b>	AlGaInP	Red	130*1	50	100*2	5	-40 to +85	-40 to +100	2.1	10	618	624	630	20	220	360		
	InGaN	Green		40					519		527	536	360		630			
	InGaN	Blue		40					464		470	476	140		250			

\*1: Total power dissipation in the case of lighting all 3 colors (reduce by 30% a color)

\*2: Duty ≤ 1/20, 1ms(FR4 50mmx50mm substrate, t=1.6mm), copper foil t=0.07mm)

## Dimensions

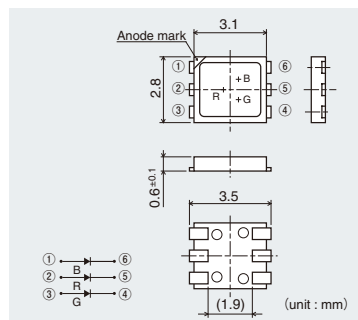

## Recommended Solder Pattern

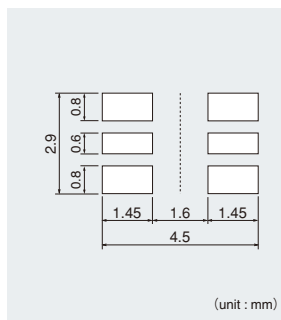

## Viewing Angle

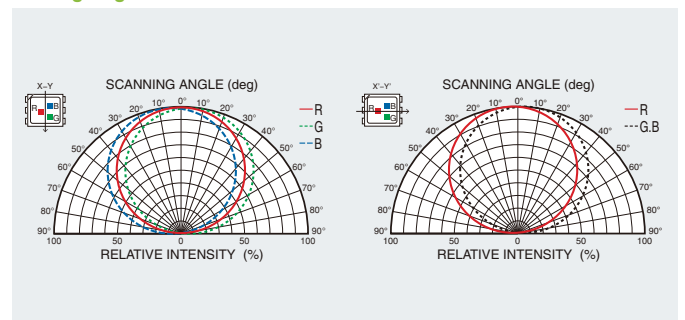

## Electrical Characteristics Curves

### Forward Voltage-Forward Current

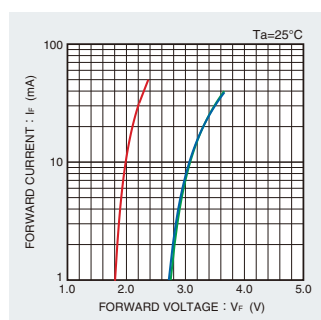

■ SMLV36RGB1B(R)  
■ SMLV36RGB1B(G)  
■ SMLV36RGB1B(B)

### Atmosphere Temperature-Relative Luminous Intensity

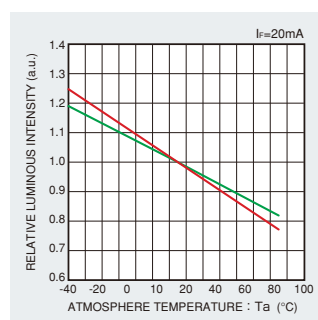

■ SMLV36RGB1B(R)  
■ SMLV36RGB1B(G)  
■ SMLV36RGB1B(B)

### Forward Current-Relative Luminous Intensity

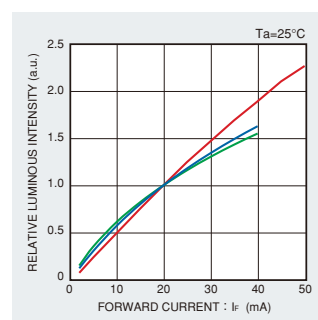

■ SMLV36RGB1B(R)  
■ SMLV36RGB1B(G)  
■ SMLV36RGB1B(B)

### Derating

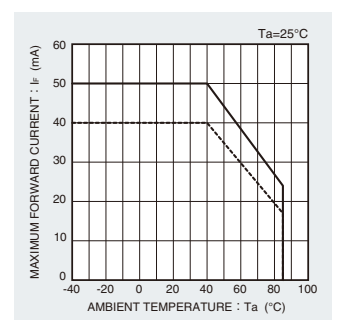

■ SMLV36RGB1B(R)  
■ SMLV36RGB1B(G)  
■ SMLV36RGB1B(B)

# SRGB-S Series

High Luminosity Side View LEDs

MSL0101 series / MSL0102 series



## Excellent color mixing characteristics ensure superior color reproduction

The side view configuration is suitable for waveguide applications.

Use in combination with top view types for easy color matching.

In addition, original mounting technology ensures excellent color mixing, making them ideal for illumination and lighting devices.

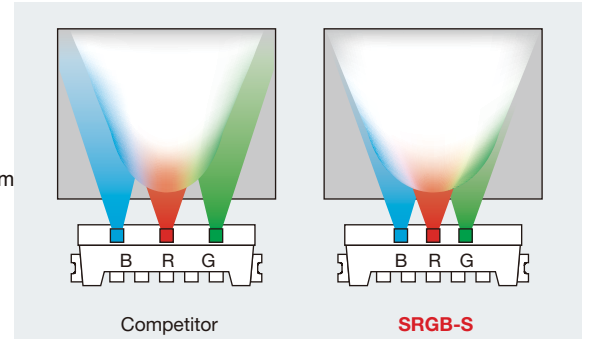

## High Luminosity White LED

White LED is newly added in the line up of high luminosity side view package.

Available to select the usage of RGB and white LED.

High power side-view LED with 60mS(max 100mA), realizing typ. 3.5cd.

Suitable for customers looking for brighter white LED.

Also, this product is high ESD with built-in diode.

### Specifications(RGB)

Part No.	Chip Structure	Emitted Color	Absolute Maximum Ratings (Ta=25°C)						Electrical and Optical Characteristics (Ta=25°C)										
			Power Dissipation Pd(mW)	Forward Current If(mA)	Peak Forward Current Ifp(mA)	Reverse Voltage Vr(V)	Operating Temperature Topr(°C)	Storage Temperature Tstg(°C)	Forward Voltage Vf(Typ.(V)/If(mA))	Reverse Current Ir(Max.(μA)/Vr(V))	Dominant Wavelength λD (Min.(nm)/Typ.(nm)/Max.(nm))			Luminous Iv (Min.(mcd)/Typ.(mcd)/If(mA))					
■	AlGaInP	Red		50					2.1		10	5	619	624	629		450	700	
■ MSL0101RGB	InGaN	Green	400	40	100*	5	-40 to +85	-40 to +100	3.3	20			520	527	535	20	710	1200	20
■		Blue							3.2				465	470	475		220	400	

\* Duty1/20, 1ms

### Specifications(White)

Part No.	Chip Structure	Emitted Color	Absolute Maximum Ratings (Ta=25°C)						Electrical and Optical Characteristics (Ta=25°C)									
			Power Dissipation Pd(mW)	Forward Current If(mA)	Peak Forward Current Ifp(mA)	Reverse Voltage Vr(V)	Operating Temperature Topr(°C)	Storage Temperature Tstg(°C)	Forward Voltage Vf(Typ.(V)/If(mA))	Reverse Current Ir(Max.(μA)/Vr(V))	Chromaticity Coordinates (x, y)		IF(mA)	Luminous Iv (Min.(mcd)/Typ.(mcd)/If(mA))				
□ MSL0102WB	InGaN	White	400	100	100*	5	-40 to +85	-40 to +100	3.2	60	100	5	(0.30, 0.28)		60	3300	5800	60

\* Duty1/10, 1kHz

### Dimensions

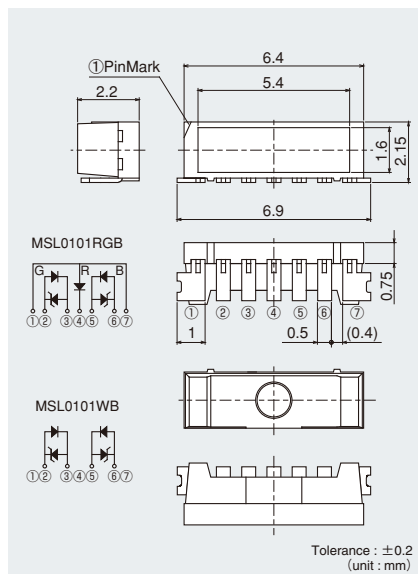

### Recommended Solder Pattern

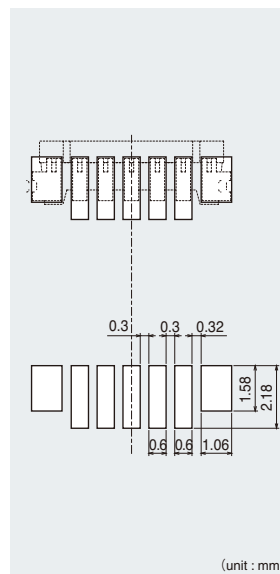

### Viewing Angle

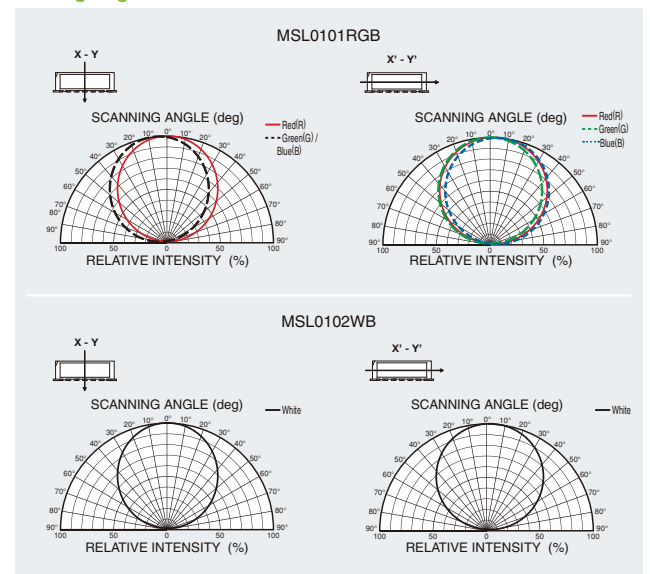

**Electrical Characteristics Curves**

**Forward Voltage-Forward Current**

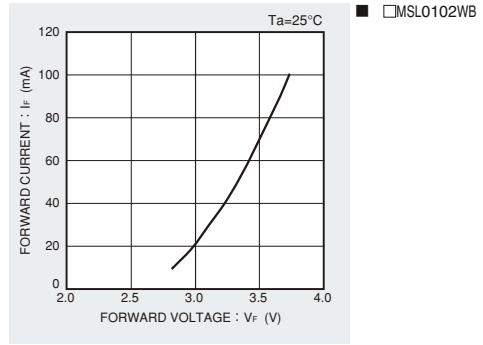
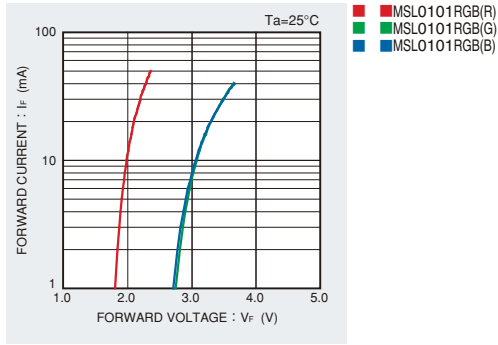

**Atmosphere Temperature-Relative Luminous Intensity**

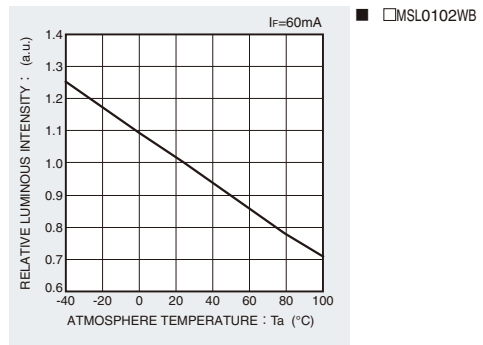
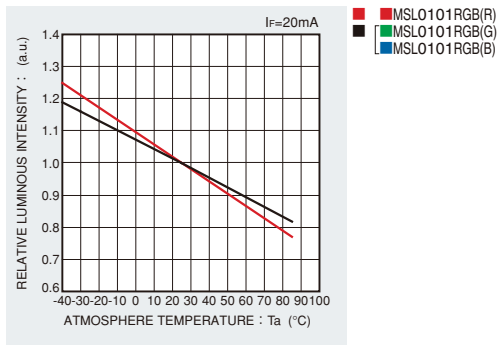

**Forward Current-Relative Luminous Intensity**

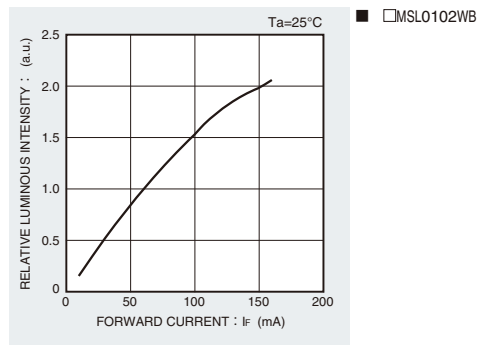
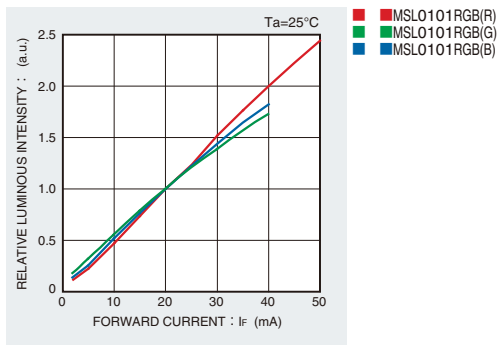

**Derating**

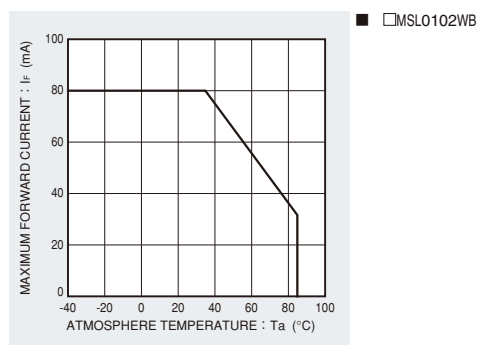
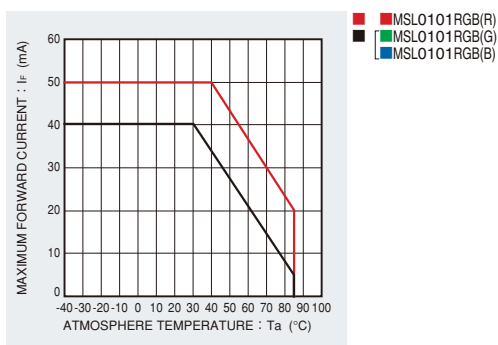



# Lamp

## Wide Viewing Angle Oval Type Lamp LEDs SLD430 / SLI-430 series



### Wide viewing angle made possible by Rohm's original lens design

Use of oval lens made wide viewing angle on behalf of narrow viewing angle at vertical.

Therefore it has vivid view from the side, and is suitable for displays.

Also it is about 1.4 times brighter than the product of same viewing angle, for it condenses the light to the cross direction.

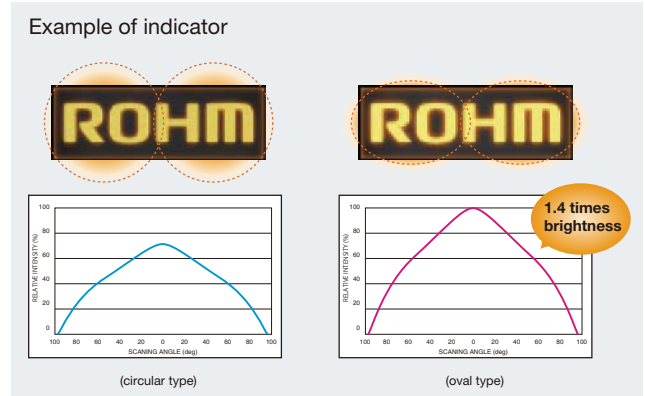

### Specifications

Part No.	Chip Structure	Emitted Color	Absolute Maximum Ratings (Ta=25°C)					Electrical and Optical Characteristics (Ta=25°C)									
			Power Dissipation Pb(mW)	Forward Current IF(mA)	Peak Forward Current IFF(mA)	Reverse Voltage VR(V)	Operating Temperature Topr(°C)	Storage Temperature Tstg(°C)	Forward Voltage V <sub>F</sub> Typ.(V)	IF(mA)	Reverse Current I <sub>R</sub> Max.(μA)	V <sub>R</sub> (V)	Dominant Wavelength λ <sub>D</sub> Typ.(nm)	IF(mA)	Min. Luminous Iv (mcd)	Typ. Luminous Iv (mcd)	IF(mA)
■ SLI-430U2R	AlGaInP	Red	75	30	100*	9	-40 to +85	-40 to +100	2.0	20	10	9	620	20	220	400	20
■ SLI-430DU		Orange											605		470		
■ SLI-430Y2U		Yellow											590		330	500	
■ SLI-430MG		Yellowish Green											570		68	120	
■ SLD430BD2W	InGaN	Blue	120			5	-20 to +80	-30 to +100	3.2		5		470	330	560		
□ SLD430WBD2PT	White	(0.31, 0.31)											680	1850			

\* Duty1/10, 1kHz

### Dimensions

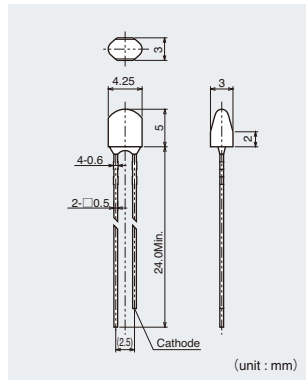

### Recommended Solder Pattern

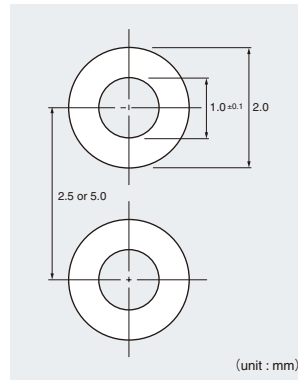

### Viewing Angle

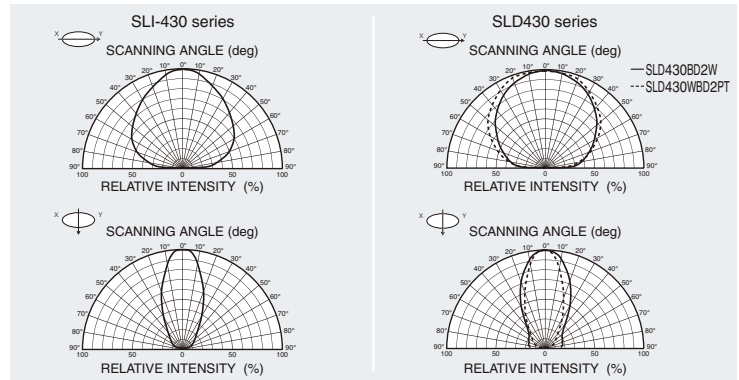

### Electrical Characteristics Curves

#### Forward Voltage-Forward Current

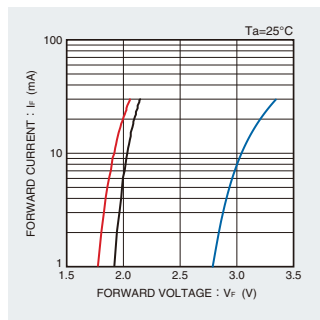

#### Atmosphere Temperature-Relative Luminous Intensity

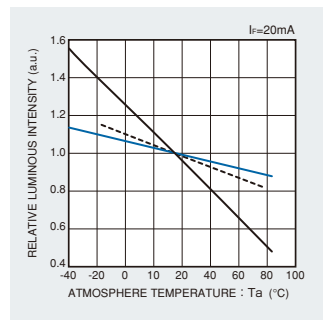

#### Forward Current-Relative Luminous Intensity

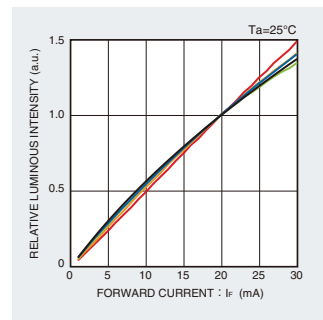

#### Derating

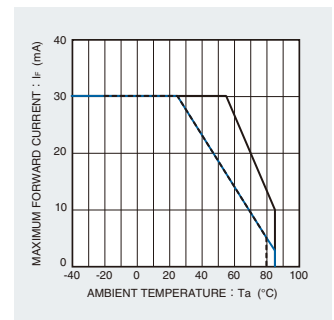

- SLI-430U2R
- SLI-430DU
- SLI-430Y2U
- SLI-430MG
- SLD430BD2W
- SLD430WBD2PT

- SLI-430U2R
- SLI-430DU
- SLI-430Y2U
- SLI-430MG
- SLD430BD2W
- SLD430WBD2PT

- SLI-430U2R
- SLI-430DU
- SLI-430Y2U
- SLI-430MG
- SLD430BD2W
- SLD430WBD2PT

- SLI-430U2R
- SLI-430DU
- SLI-430Y2U
- SLI-430MG
- SLD430BD2W
- SLD430WBD2PT



# Lamp

High Luminosity Wide Viewing  
Angle Lamp LEDs

**SLI-565 series**



Color Type **Y**

## High luminosity LED of viewing angle 25°

Viewing angle 25° type is newly added in the Rohm's lamp LEDs.

### Dot Matrix Examples(vision of oblique direction)

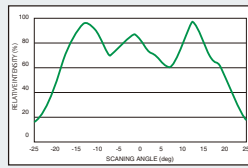
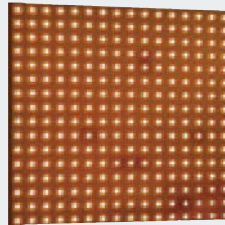

<Conventional product(wide viewing angle)>

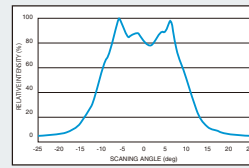
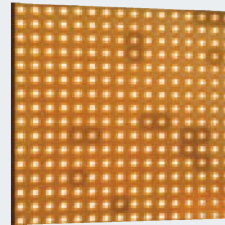

<Conventional product(narrow viewing angle)>

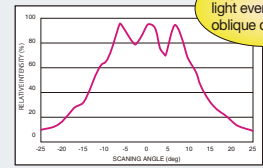
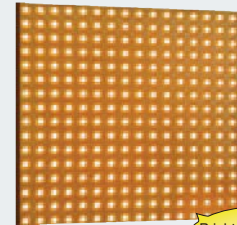

<SLI-565>

Bright and uniform light even from the oblique direction

## Specifications

Part No.	Chip Structure	Emitted Color	Absolute Maximum Ratings (Ta=25°C)						Electrical and Optical Characteristics (Ta=25°C)								
			Power Dissipation Pd(mW)	Forward Current If(mA)	Peak Forward Current Ifp(mA)	Reverse Voltage Vr(V)	Operating Temperature Topr(°C)	Storage Temperature Tstg(°C)	Forward Voltage Vf Typ.(V)	Reverse Current Ir Max.(μA)	Reverse Current Ir Vr(V)	Dominant Wavelength λD Typ.(nm)	Operating Current If(mA)	Luminous Flux Φv Min.(mcd)	Luminous Flux Φv Typ.(mcd)	Luminous Flux Φv If(mA)	
■ SLI-565Y5C	AlGaInP	Yellow	125	50	200*	9	-40 to +85	-40 to +100	2.0	20	10	9	590	20	1500	3400	20

\* Duty1/10, 1kHz

## Dimensions

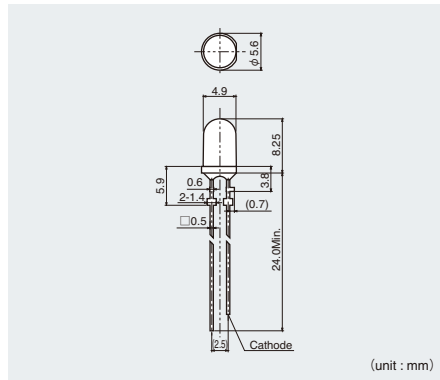

(unit : mm)

## Recommended Solder Pattern

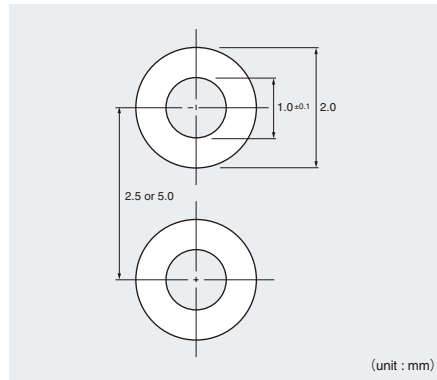

(unit : mm)

## Viewing Angle

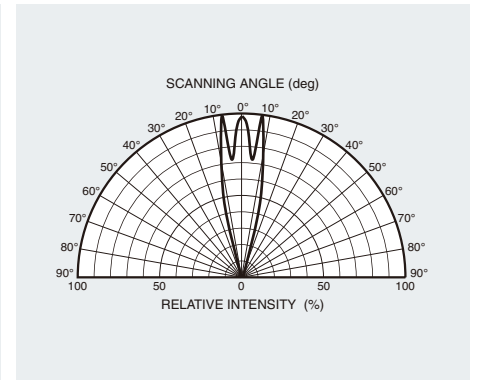

## Electrical Characteristics Curves

### Forward Voltage-Forward Current

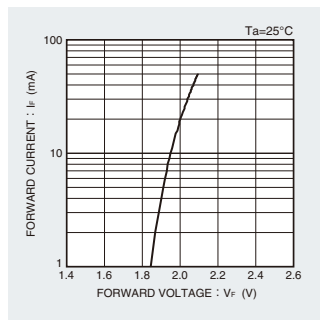

■ SLI-565Y5C

### Atmosphere Temperature-Relative Luminous Intensity

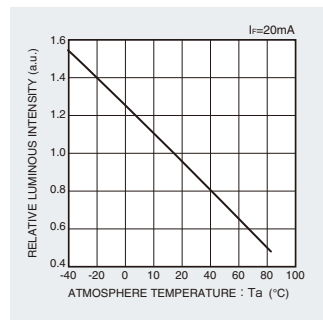

■ SLI-565Y5C

### Forward Current-Relative Luminous Intensity

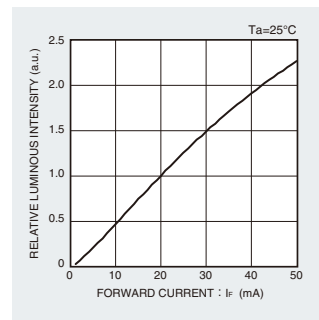

■ SLI-565Y5C

### Derating

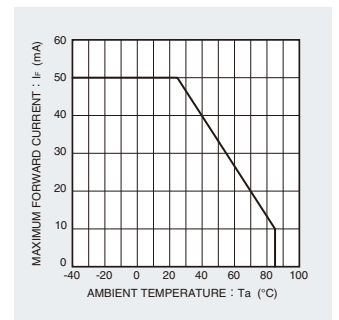

■ SLI-565Y5C

## Part No. Structure (SMD LEDs)

- Appoint by part names when ordering
- Refer to each category below for details of part No. structure
- Skip if there is a blank space
- \*Part names are appointed individually per each ranks.
- \*Please refer to specifications sheet for details.

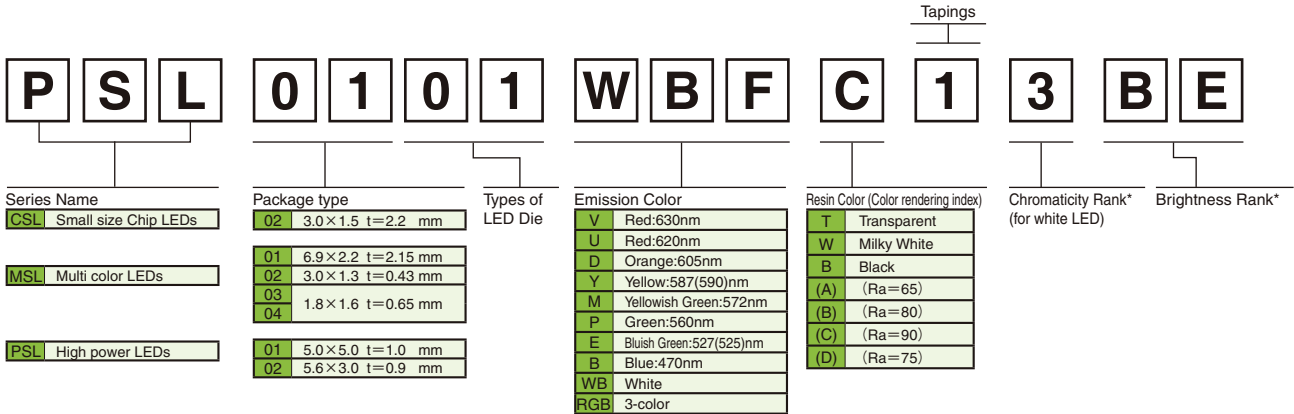
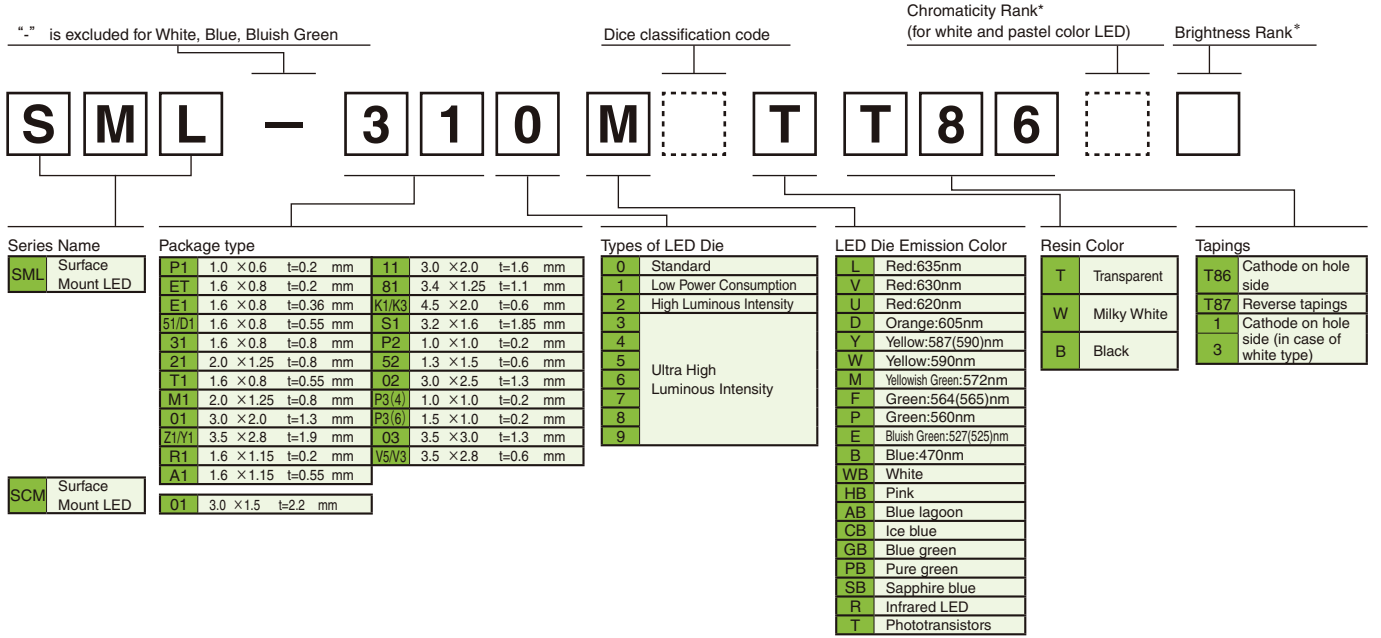



- 1) The information contained in this document is provided as of 1st October, 2012 .
- 2) The information contained herein is subject to change without notice. Before you use our Products, please contact our sales representative (as listed below) and verify the latest specifications.
- 3) Although ROHM is continuously working to improve product reliability and quality, semiconductors can break down and malfunction due to various factors. Therefore, in order to prevent personal injury or fire arising from failure, please take safety measures such as complying with the derating characteristics, implementing redundant and fire prevention designs, and utilizing backups and fail-safe procedures. ROHM shall have no responsibility for any damages arising out of the use of our Products beyond the rating specified by ROHM.
- 4) Examples of application circuits, circuit constants and any other information contained herein are provided only to illustrate the standard usage and operations of the Products. The peripheral conditions must be taken into account when designing circuits for mass production.
- 5) The technical information specified herein is intended only to show the typical functions of and examples of application circuits for the Products. ROHM does not grant you, explicitly or implicitly, any license to use or exercise intellectual property or other rights held by ROHM or any other parties. ROHM shall have no responsibility whatsoever for any dispute arising out of the use of such technical information.
- 6) The Products specified in this document are not designed to be radiation tolerant.
- 7) For use of our Products in applications requiring a high degree of reliability (as exemplified below), please contact and consult with a ROHM representative: transportation equipment (i.e. cars, ships, trains), primary communication equipment, traffic lights, fire/crime prevention, safety equipment, medical systems, servers, solar cells, and power transmission systems.
- 8) Do not use our Products in applications requiring extremely high reliability, such as aerospace equipment, nuclear power control systems, and submarine repeaters.
- 9) ROHM shall have no responsibility for any damages or injury arising from non-compliance with the recommended usage conditions and specifications contained herein.
- 10) ROHM has used reasonable care to ensure the accuracy of the information contained in this document. However, ROHM does not warrant that such information is error-free and ROHM shall have no responsibility for any damages arising from any inaccuracy or misprint of such information.
- 11) Please use the Products in accordance with any applicable environmental laws and regulations, such as the RoHS Directive. For more details, including RoHS compatibility, please contact a ROHM sales office as listed below. ROHM shall have regulations.
- 12) When providing our Products and technologies contained in this document to other countries, you must abide by the procedures and provisions stipulated in all applicable export laws and regulations, including without limitation the US Export Administration Regulations and the Foreign Exchange and Foreign Trade Act.
- 13) This document, in part or in whole, may not be reprinted or reproduced without prior consent of ROHM.

**ROHM Sales Offices**

Contact us for further information about the products.

<b>San Diego</b>	+1-858-625-3600	<b>Mexico</b>	+52-33-3123-2001	<b>Spain</b>	+34-9375-24320	<b>Singapore</b>	+65-6332-2322
<b>Atlanta</b>	+1-770-754-5972	<b>Brazil</b>	+55-11-3539-6320	<b>Hungary</b>	+36 1 950 5859	<b>Philippines</b>	+63-2-807-6872
<b>Boston</b>	+1-978-371-0382	<b>Dusseldorf</b>	+49-2154-921-0	<b>Russia</b>	+74 95 739 4174	<b>Thailand</b>	+66-2-254-4890
<b>Chicago</b>	+1-847-368-1006	<b>Stuttgart</b>	+49-711-7272370	<b>Seoul</b>	+82-2-8182-700	<b>Malaysia</b>	+60-3-7958-8355
<b>Dallas</b>	+1-972-473-3748	<b>France</b>	+33 (0) 1 40 60 87 30	<b>Dalian</b>	+86-411-8230-8549	<b>India</b>	+91-44-4352-0008
<b>Denver</b>	+1-303-708-0908	<b>United Kingdom</b>	+44-1-908-272400	<b>Shanghai</b>	+86-21-6279-2727	<b>Kyoto</b>	+81-44-4365-1218
<b>Detroit</b>	+1-248-348-9920	<b>Espoo</b>	+358 400 222 382	<b>Shenzhen</b>	+86-755-8307-3008	<b>Yokohama</b>	+81-45-476-2121
<b>Nashville</b>	+1-615-620-6700	<b>Salo</b>	+358-2-7332234	<b>Hong Kong</b>	+852-2740-6262		
<b>Sunnyvale</b>	+1-408-720-1900	<b>Oulu</b>	+358-400-726 124	<b>Taiwan</b>	+886-2-2500-6965		

**ROHM Co., Ltd.**

21 Saini Mizosaki-cho, Ukyo-ku,  
Kyoto 615-8585 Japan

TEL : +81-75-311-2121 FAX : +81-75-315-0172

[www.rohm.com](http://www.rohm.com)



## X-ON Electronics

Largest Supplier of Electrical and Electronic Components

*Click to view similar products for [ROHM](#) manufacturer:*

Other Similar products are found below :

[BP5034D24](#) [BP5013](#) [BP5011](#) [BP5718A12](#) [RPI-441C1](#) [RN142ZST2R](#) [SML-012VTT86A](#) [RB055LA-40TR](#) [RB886YT2R](#) [RB851YT2R](#)  
[1SS400GT2R](#) [MCR100JZHF30R1](#) [MCR100JZHJ150](#) [MCR50JZHFLR820](#) [MCR50JZHJ330](#) [ML610Q793-SDK](#) [MNR34J5ABJ223](#)  
[BD750L2FP-EVK-301](#) [BD9009HFP-EVK-001](#) [BD9285F-GE2](#) [SCT2H12NZGC11](#) [RB168L-60TE25](#) [MCR100JZHF1301](#) [MCR100JZHJ4R3](#)  
[MCR100JZHJ513](#) [MCR100JZHJ683](#) [BD9B300MUV-EVK-001](#) [MNR12ERAPJ100](#) [MNR34J5ABJ221](#) [BD9060HFP-EVK-001](#)  
[BD9611MUV-EVK-001](#) [BD9C601EFJ-EVK-001](#) [BD9D321EFJ-EVK-101](#) [BD9G341AEFJ-EVK-101](#) [BA7603F-E2](#) [BD95820N-LB](#)  
[BD9A100MUV-EVK-001](#) [BD9C501EFJ-EVK-001](#) [BU90005GWZ-E2-EVK-101](#) [BH1715FVC-TR](#) [LA-401XD](#) [RSX301L-30TE25](#)  
[BH1790GLC-EVK-001](#) [BU33UV7NUX-EVK-101](#) [BD9B301MUV-EVK-101](#) [BA7071F-E2](#) [SK-AD01-D62Q1367TB](#) [BM2P129TF-EVK-001](#)  
[RB-D62Q1577TB100](#) [RB-D62Q1552GA64](#)