

SLR-37 series

LED, reflecting, high brightness, 3.0 mm

The SLR-37 series LEDs are small, reflecting, high brightness single color LEDs.

Dimensions (Units : mm)

Features

- single LED per package
- diameter of lens = 3.1 mm
- height as low as 4.7 mm
- mounting pitch as small as 2.5 mm
- available in red, orange, yellow, and green with a choice of tinted diffused or tinted non-diffused lens
- available on tape for mounting by an automatic machine

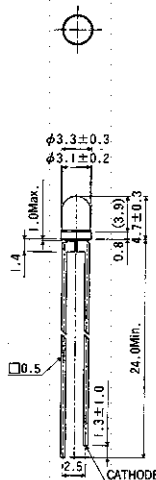

Selection guide

Part no	SLR-37VR	SLR-37DU	SLR-37YY	SLR-37MG
Color & wavelength	Red, 650 nm	Orange, 610 nm	Yellow, 585 nm	Green, 563 nm
Lens	Tinted diffused	Tinted diffused	Tinted diffused	Tinted diffused
Availability	semi-std	semi-std	semi-std	semi-std
Part no	SLR-37VC			SLR-37MC
Color & wavelength	Red, 650 nm			Green, 563 nm
Lens	Tinted non-diffused			Tinted non-diffused
Availability	semi-std			semi-std

Absolute maximum ratings ($T_a = 25^\circ\text{C}$)

Parameter	Symbol	Red	Orange	Yellow	Green	Unit	Conditions
		SLR-37VR SLR-37VC	SLR-37DU	SLR-37YY	SLR-37MG SLR-37MC		
Power dissipation	P_d	60	60	60	75	mW	
Forward current	I_F	20	20	20	25	mA	
Peak forward current	I_{FP}	60	60	60	60	mA	Pulse width 1 ms, duty 20%
Reverse voltage	V_R	3	3	3	3	V	
Operating temperature	T_{opr}	-25 ~ +85				$^\circ\text{C}$	
Storage temperature	T_{stg}	-30 ~ +100				$^\circ\text{C}$	

SLR-37 series Direct-mount LED lamps, high brightness, reflector type

Electro-optical characteristics (T_a = 25°C)

Parameter	Symbol	Red		Orange		Yellow		Green		Unit	Conditions
		Typ	Max	Typ	Max	Typ	Max	Typ	Max		
Forward voltage	V _F	2.0	3.0	2.0	3.0	2.1	3.0	2.1	3.0	V	I _F = 10 mA
Reverse current	I _R		10		10		10		10	μA	V _R = 3 V
Peak wavelength	λ _p	650		610		585		563		nm	I _F = 10 mA
Spectral half-width	Δλ	40		40		40		40		nm	I _F = 10 mA
Emission power half angle	2θ _{1/2}	50		55		55		50		deg	Non-diffused
		55		55		55		55			Diffused

Luminous intensity

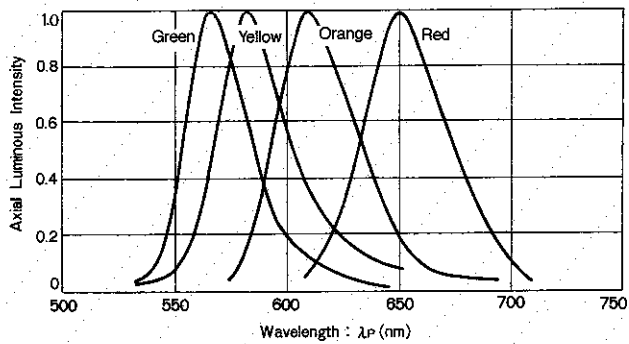

Luminous intensity

Part no.	Color	λ _p	Min	Typical	Max	Unit	Conditions
SLR-37VR	Red	650	3.6	10		mcd	I _F = 10 mA
SLR-37VC			5.6	16		mcd	
SLR-37DU	Orange	610	3.6	10		mcd	
SLR-37YY	Yellow	585	3.6	10		mcd	
SLR-37MG	Green	563	5.6	16		mcd	
SLR-37MC			9.0	25		mcd	

Electrical characteristic curves 1 (Red)

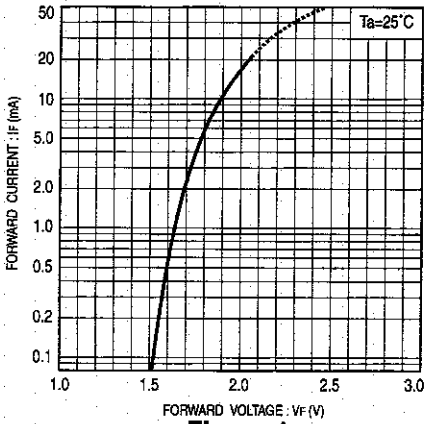

Figure 1

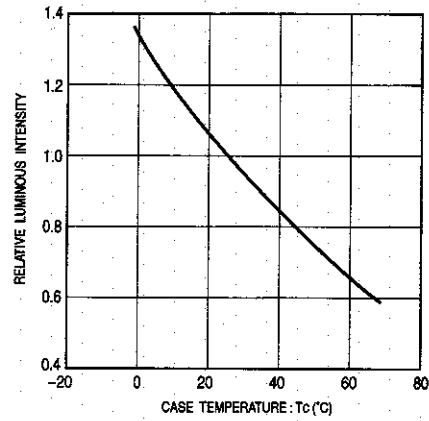

Figure 2

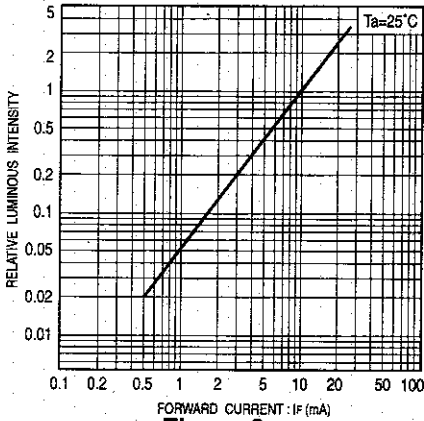

Figure 3

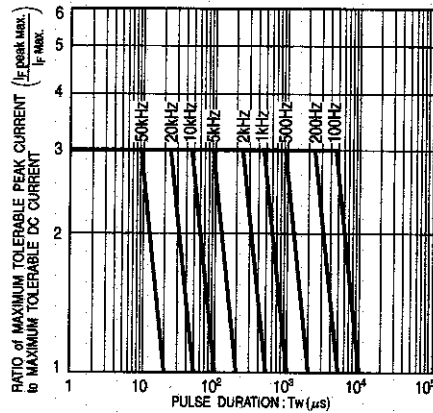

Figure 4

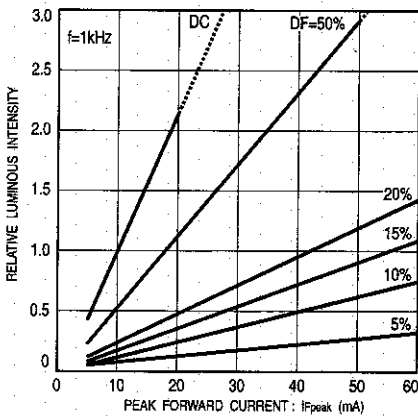

Figure 5

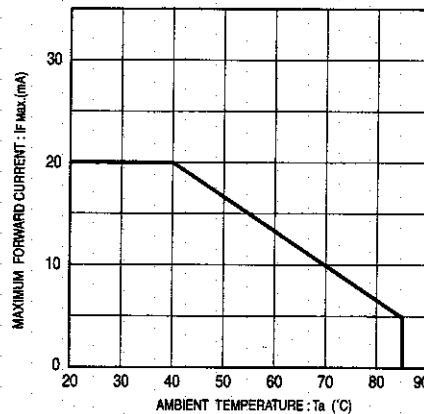

Figure 6

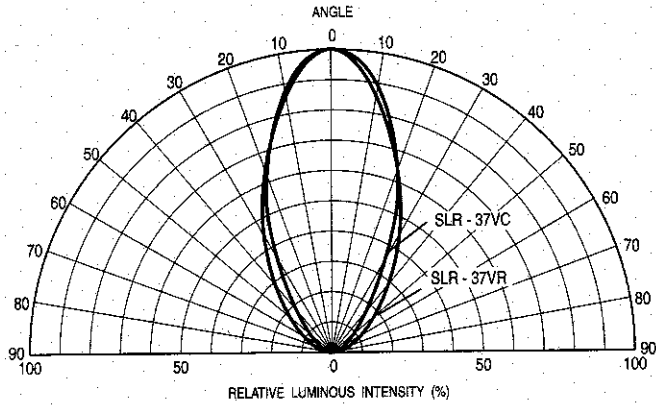

Figure 7 Directional pattern (red)

Electrical characteristic curves 2 (Orange)

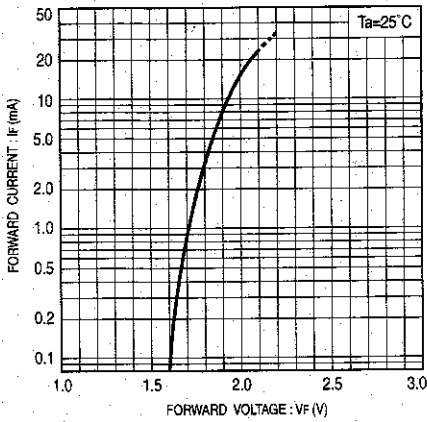

Figure 8

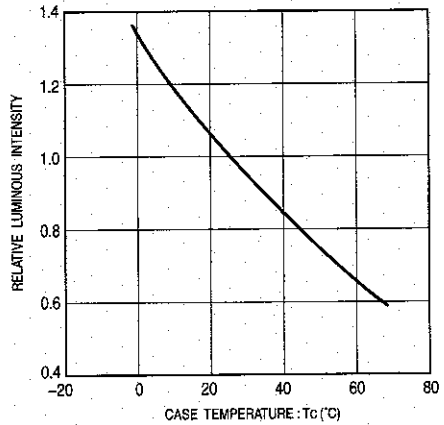

Figure 9

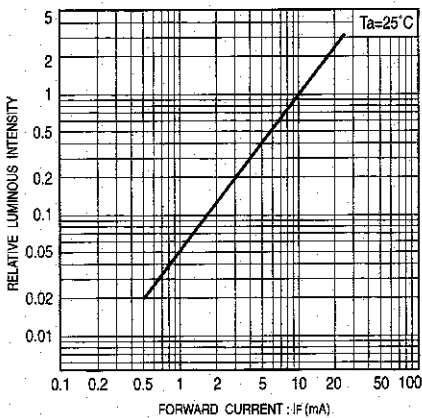

Figure 10

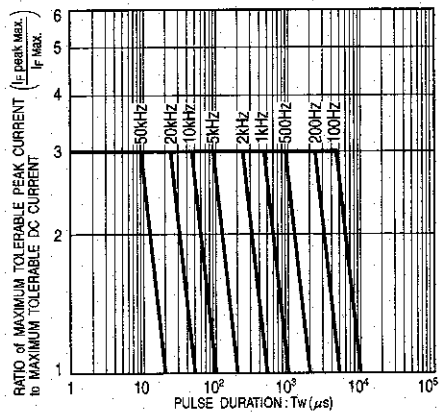

Figure 11

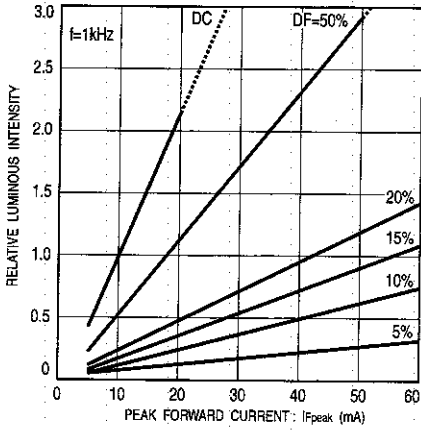

Figure 12

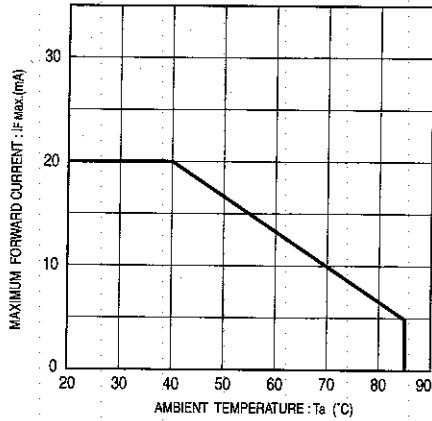

Figure 13

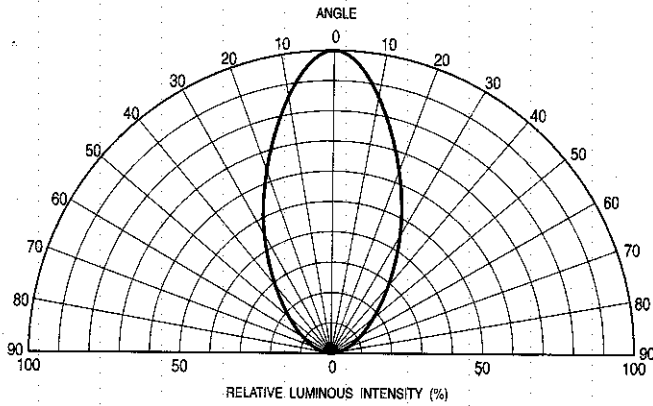

Figure 14 Directional pattern (orange)

Electrical characteristic curves 3 (Yellow)

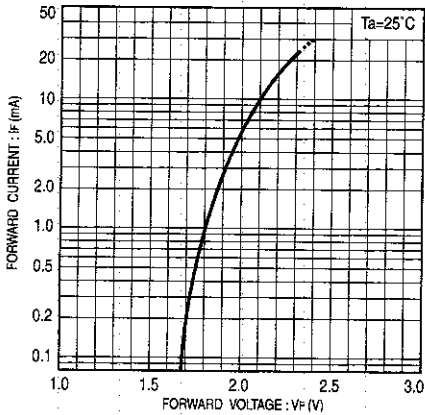

Figure 15

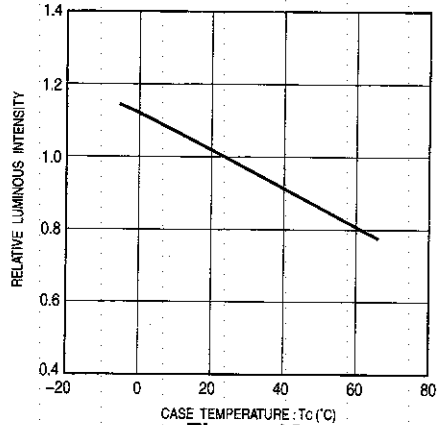

Figure 16

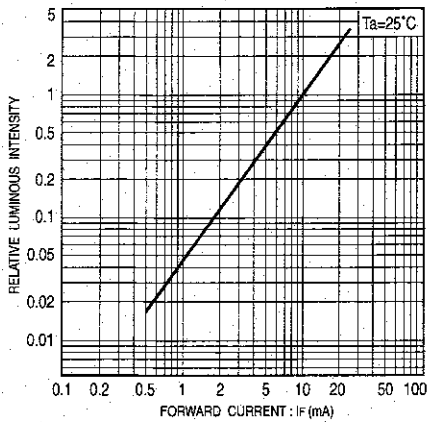

Figure 17

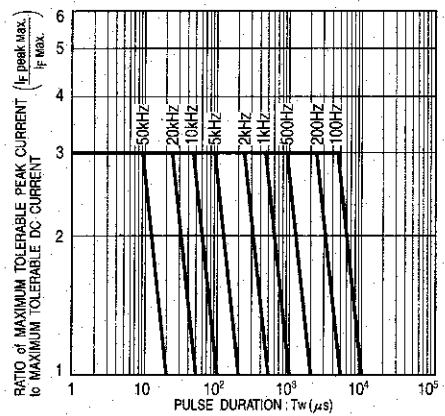

Figure 18

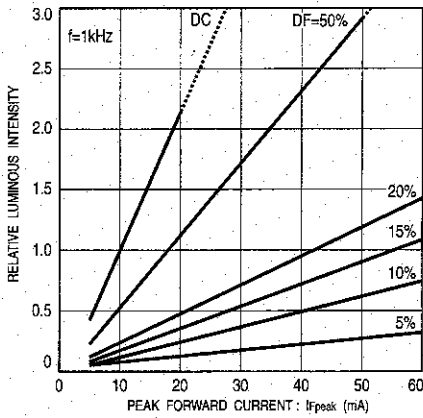

Figure 19

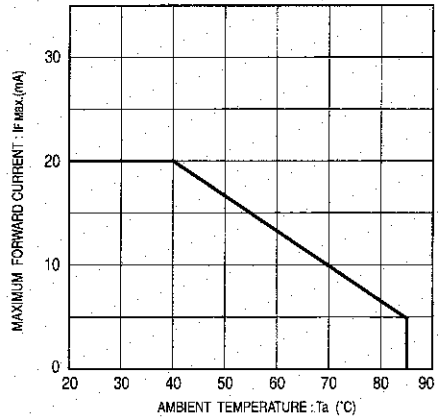

Figure 20

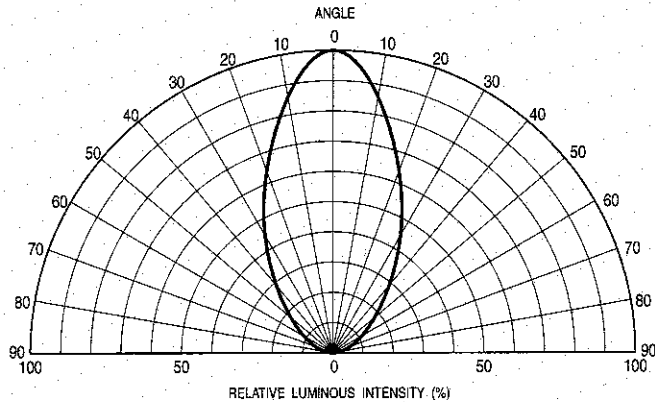

Figure 21 Directional pattern (yellow)

Electrical characteristic curves 4 (Green)

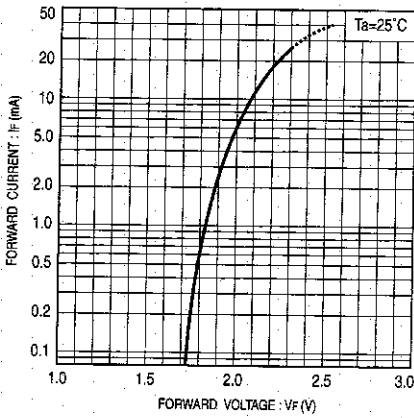

Figure 22

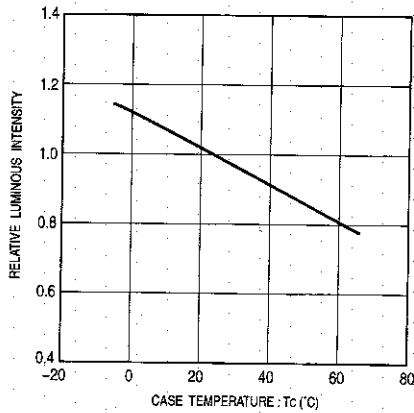

Figure 23

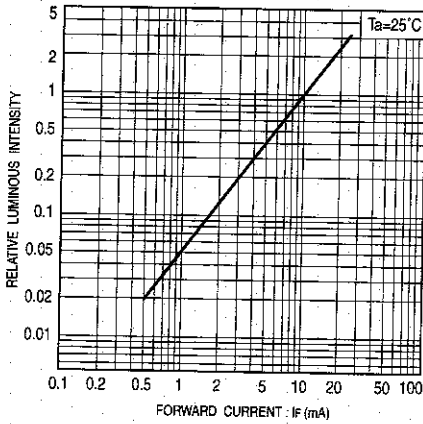

Figure 24

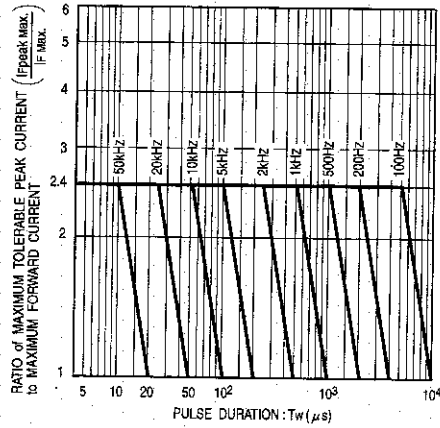

Figure 25

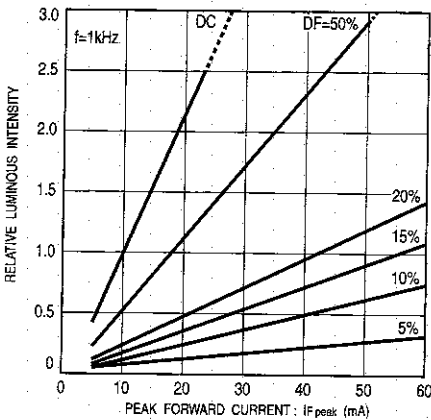

Figure 26

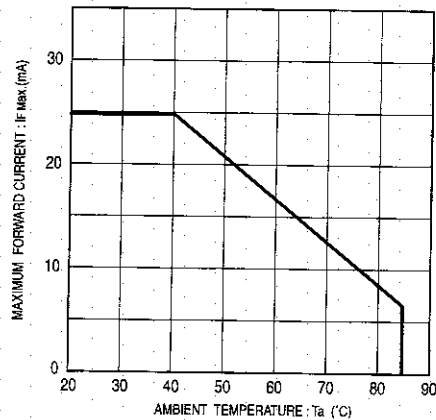

Figure 27



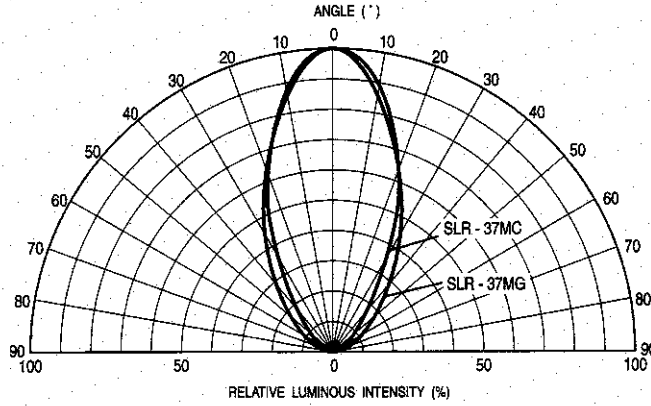

Figure 28 Directional pattern (green)

X-ON Electronics

Largest Supplier of Electrical and Electronic Components

Click to view similar products for [Standard LEDs - Through Hole category](#):

Click to view products by [ROHM manufacturer](#):

Other Similar products are found below :

[LTL-10254W](#) [LTL-1214A](#) [LTL-3251A](#) [LTL-4262N](#) [LTL-433P](#) [LTL-5234](#) [LTL87HTBK](#) [LTL-87HD4B](#) [HLMP-EL30-PS0DD](#)
[1L0532V23G0TD001](#) [NSPW500CS](#) [NTE30036](#) [NTE30044](#) [NTE30059](#) [NTE3020](#) [LD CQDP-1U3U-W5-1-K](#) [LO566UHR3-70G-A3](#)
[LP379PPG1C0G0300001](#) [SLX-LX3044GD](#) [SLX-LX3044ID](#) [SLX-LX3044YD](#) [1.90690.3330000](#) [SSS-LX4673ID-410B](#) [1L0532Y24I0TD001](#)
[264-7SYGD/S530-E2](#) [HLMP-1301-G00FG](#) [HLMP1385](#) [LTL-10224W](#) [LTL-1224A](#) [LTL-1234A](#) [LTL-2251AT](#) [LTL-403HR](#) [LTL-4222](#)
[LU7-E-B](#) [4380H1](#) [TLHY44K1L2](#) [HLMP-3962-F0002](#) [HLMP-GG15-R0000](#) [323-2SURD/S530-A3](#) [L53SRC/E-Z](#) [L-7679C1ZGC](#) [4302T1-5V](#)
[4306D23](#) [4363D1/5](#) [WP1503SRC/J4](#) [WP153GDT](#) [WP153YDT](#) [WP1543SGC](#) [WP1543SURC](#) [WP53MGD](#)