

Magnetic Connecting System – Power and Data Transmission for LEV

## RoPD<sup>®</sup> Connectors

AUTOMOTIVE

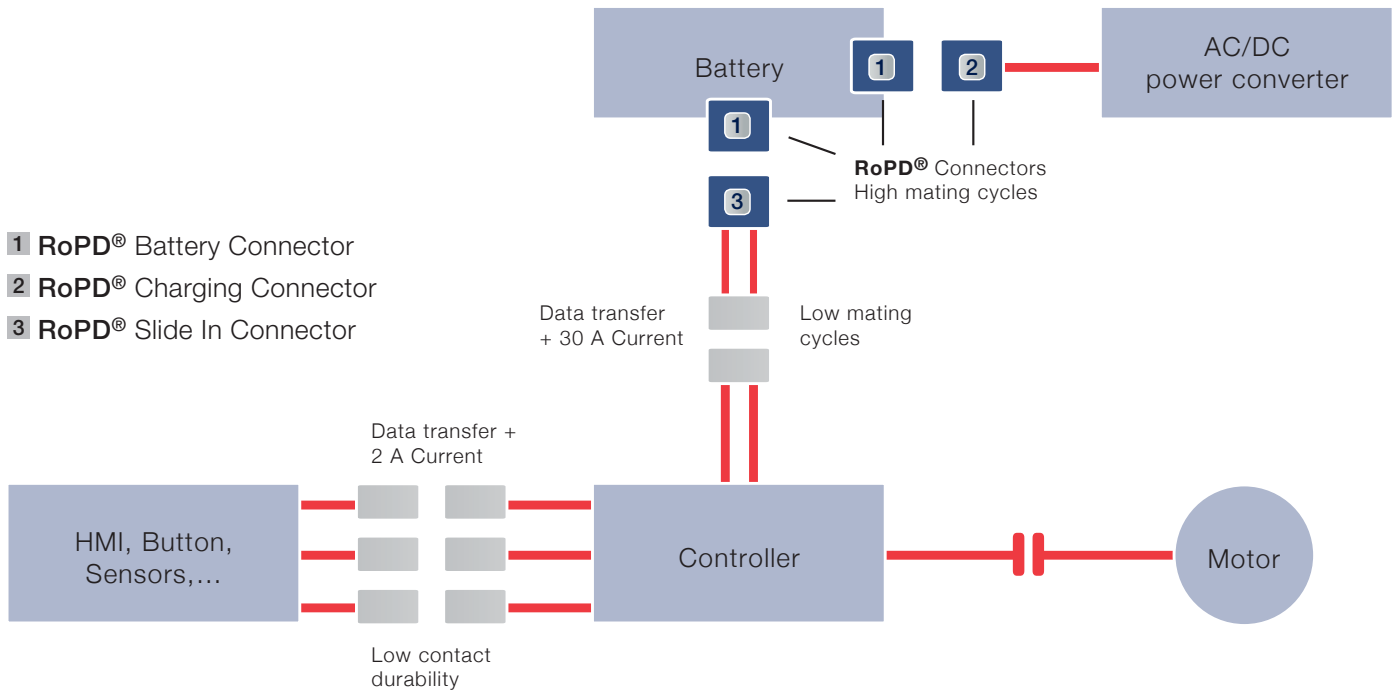



## RoPD® – Rosenberger Power Data

### RoPD® Connectors – Exploring Generation LEV

Rosenberger Power Data Connectors are a revolutionary magnetic connector system\*\* – developed for the Light Electric Vehicles Industry (LEV). They are especially suited for data communication and power transmission of voltages up to 60 V DC and current loads up to 40 A.

RoPD Connectors utilize magnetic locking with a perfect self-mating capability instead of a mechanical plug-in mount. Forced disconnection will not damage the connector or the LEV.

#### Product Features

- Magnetic locking mechanism
- 4 pins for data communication and 2 pins for power transmission
- 100 % self-location
- Shallow mounting depth
- Waterproof and robust
- Shock- and vibration proof
- Reliable contact pressure
- Zero-force mating
- High number of mating cycles



\*\* European Patent No. EP 1 537 632



## Introduction

### Technology

The contact system consists of 4 data contacts and 2 power transmission pins. The system is not hot-plugable.

Upon successful connection, the data contacts activate the power contacts. The power contacts are based on a pin and socket principle, which balances out tolerances through contact springs and is therefore suitable for high quantity of mating cycles. In the automobile industry this power connection system has proved itself time and again. The 4 data contacts can be used as a BUS-System with additional supply voltage.

Versions of these magnetic Rosenberger Power Data connectors are also suitable for EnergyBus application.

### Perfect handling

- No risk of canting or similar
- Reliable connections even for hard-to-reach positions
- Forced disconnection causes no damage to connector or vehicle





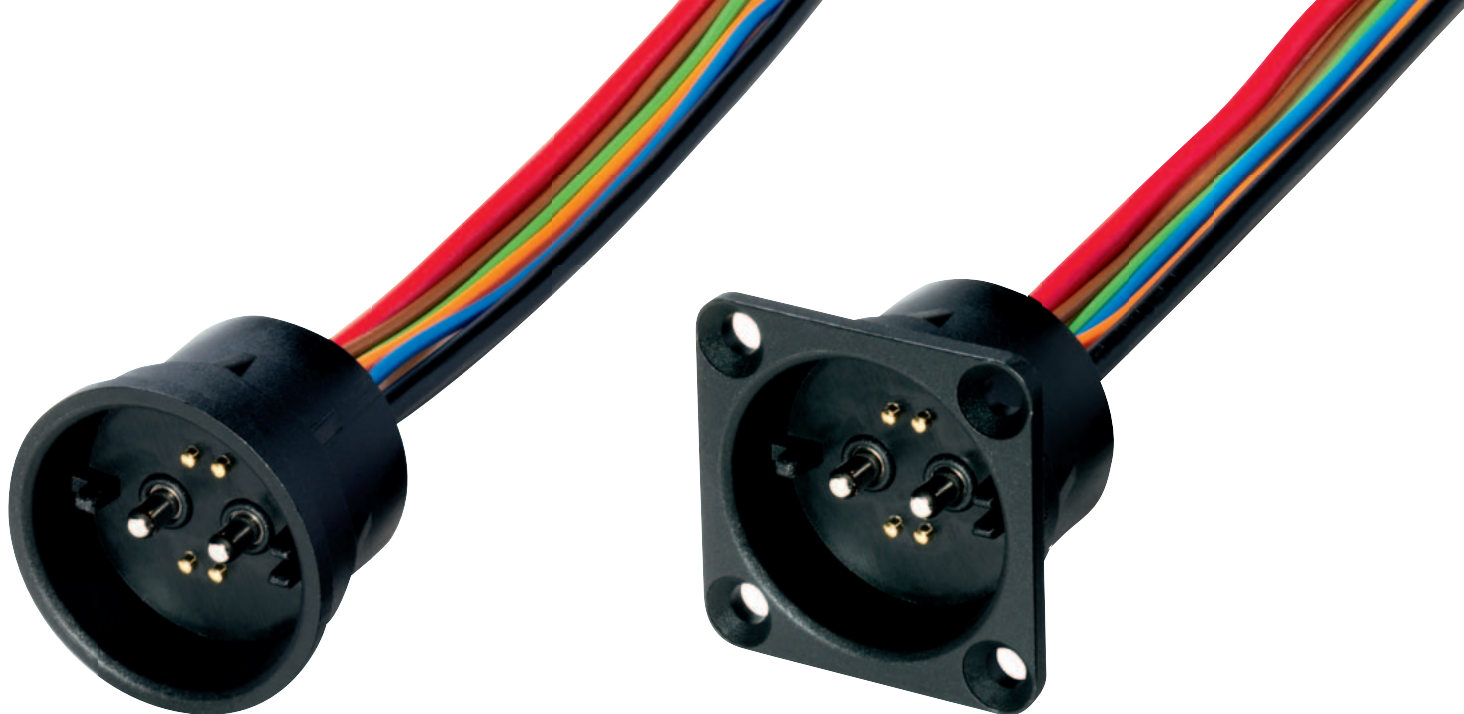

### Applications

RoPD® Connectors are suitable for the Light Electric Vehicles Industry (LEV) for data communication and power transmission, e.g. pedelecs, e-bikes, e-scooters and wheelchairs.



## Product Portfolio

### RoPD® Cable Assemblies & Accessories

Rosenberger No.	Max. Current Load	Assembly incl. Connector	
C001-04-xxx-y*	10 A	Charging connector jack straight	
<b>C003-03-xxx-y*</b>	30 A		
C001-08-xxx-y*	10 A	Charging connector jack right angle	
<b>C003-04-xxx-y*</b>	30 A		
C001-A2-xxx-y*	10 A	Slide-in panel jack straight round flange	
<b>C003-A2-xxx-y*</b>	30 A		
C006-A2-xxx-y*	40 A		
C001-10-xxx-y*	10 A	Slide-in panel jack straight 4-hole-flange	
<b>C003-BB-xxx-y*</b>	30 A		
C006-B2-xxx-y*	40 A		
C001-21-xxx-y*	10 A	Battery panel plug straight round flange	
<b>C003-17-xxx-y*</b>	30 A		
C006-17-xxx-y*	40 A		
C001-11-xxx-y*	10 A	Battery panel plug straight 4-hole-flange	
<b>C003-B1-xxx-y*</b>	30 A		
C006-B1-xxx-y*	40 A		
M4Z003-000		Protection cap for plug connectors	

\* please fill in: xxx requested length in mm, y coding  
Further or customized versions on request



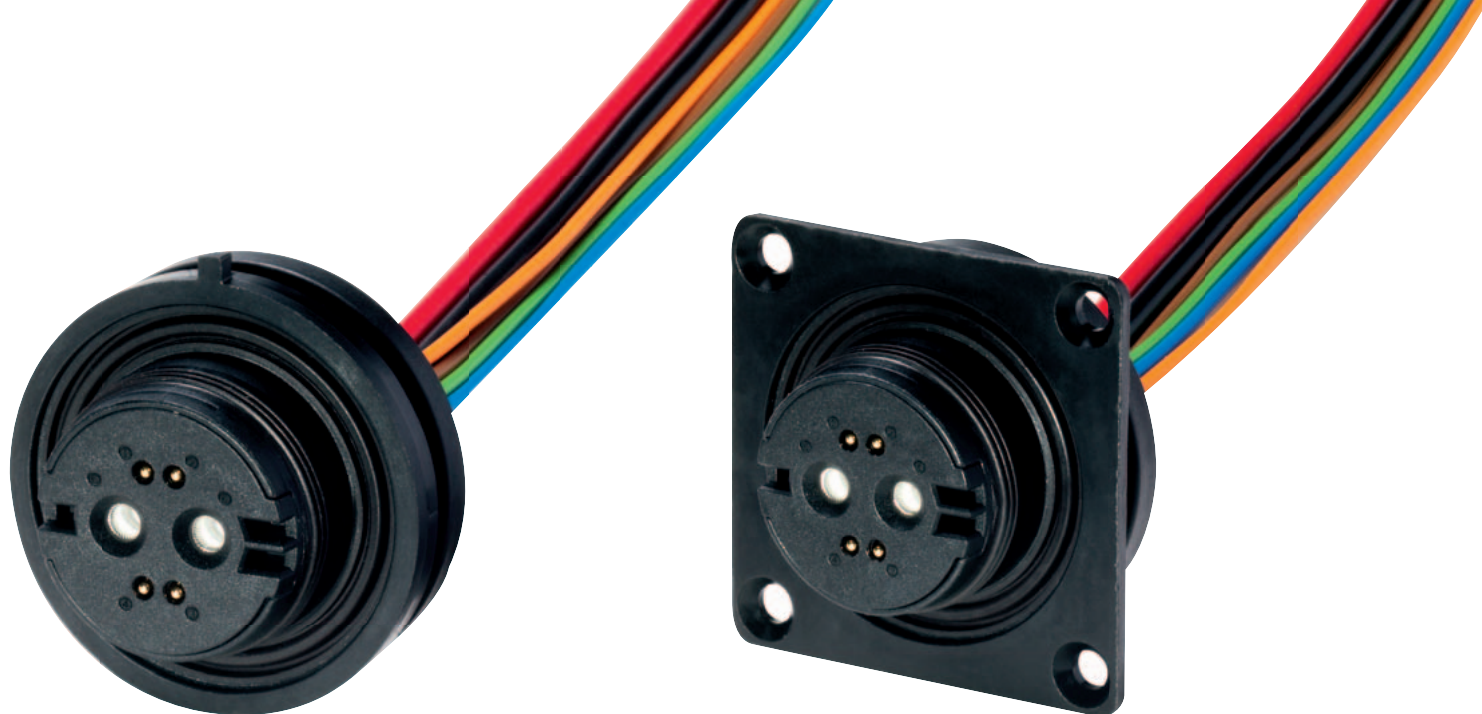

## Technical Data

### Product Features

- Current: 10 A, 30 A, 40 A
- Voltage: up to 60 V DC
- Mating cycles > 2500
- UV-resistant
- Waterproof: IP 65 plug, IP 64/IP 67 jack (mated connection)

### Technical Data RoPD® Cable Assemblies

	Cable Assembly Types		
	C001-...-xxx-y*	C003-...-xxx-y*	C006-...-xxx-y*
<b>Electrical data</b>			
Rated voltage, Power Pins	60 V DC	60 V DC	60 V DC
Max. current load, Power Pins (room temperature)	10 A	30 A	40 A
Rated voltage, Signal Pins	12 V	12 V	12 V
Max. current load, Signal Pins (room temperature)	2 A	2 A	2 A
<b>Mechanical data</b>			
Locking mechanism	magnetic	magnetic	magnetic
Mating cycles without load	> 2500 cycles	> 2500 cycles	> 2500 cycles
Power pin wire cross section	1 mm <sup>2</sup>	2.5 mm <sup>2</sup>	6 mm <sup>2</sup>
Mounting cut-out, male	Ø 25 mm	Ø 25 mm	Ø 25 mm
Mounting depth (with/without fastener ring)	20 mm	20 mm	20 mm
<b>Environmental data</b>			
Dust- and water resistance			
Plug (frontside, installed)	IP 65	IP 65	IP 65
Jack (connected with Plug)	IP 64/IP 67	IP 64/IP 67	IP 64/IP 67

\* please fill in: xxx requested length in mm, y coding



## Automotive – RoPD® Website

For more information, refer to our website:  
[www.rosenberger.com/ropd](http://www.rosenberger.com/ropd)

### **Rosenberger**

#### **Hochfrequenztechnik GmbH & Co. KG**

Hauptstraße 1 | 83413 Fridolfing

P.O. Box 1260 | 84526 Tittmoning

Germany

Phone +49 (0)8684 18-0

[info@rosenberger.de](mailto:info@rosenberger.de)

[www.rosenberger.com](http://www.rosenberger.com)

Certified by ISO/TS 16949 · DIN EN 9100 · ISO 9001 · ISO 14001

Order No.  
pA 235482 · Info270RoPDFly  
2000/2016

Rosenberger® and RoPD® are registered trademarks of Rosenberger Hochfrequenztechnik GmbH & Co. KG.  
All rights reserved.

© Rosenberger 2016

## X-ON Electronics

Largest Supplier of Electrical and Electronic Components

*Click to view similar products for [Specialised Cables](#) category:*

*Click to view products by [Rosenberger](#) manufacturer:*

Other Similar products are found below :

[603PT6](#) [603SS6L](#) [604PT6](#) [604SS6](#) [706000D02F200](#) [910640](#) [1200740077](#) [1200740114](#) [AC172](#) [ACL-SSI-4](#) [R88ACAKA0015SRE](#)  
[R88ACAWL005SDE](#) [R88ACRGD0R3C](#) [1300150047](#) [1300660036](#) [1302262116](#) [1300150149](#) [1300220020](#) [1300220104](#) [1300220119](#)  
[1301240492](#) [1301810221](#) [1365323-1](#) [1613055](#) [176P12](#) [1971465-2](#) [20240400003](#) [20240400013](#) [2085828-1](#) [20886510030](#) [2-22733-8](#) [22733-](#)  
[8](#) [CB-5PSBC-RS](#) [CB-704EC-RS](#) [CB-BATACC-RS](#) [CB-JST3PSW-RS](#) [CB-M12COM-R10](#) [25AC84](#) [25AK84X](#) [25AU25](#) [25FN82](#) [3011-03](#)  
[AC118](#) [ACL-HHS-1M\(CAT5E\)](#) [SSL009PC2DC012N](#) [FC2A-KC6C](#) [2085828-2](#) [20886510150](#) [CCS-FCB-5](#) [CCSFCBF2](#)