

ALUMINUM ELECTROLYTIC CAPACITORS SPECIFICATION SHEET

CUSTOMER PART No.		
Rubycon PART No.	YXF SERIES (Option code : FFC)	
DRAWING No.	REE – 116744	ISSUE No. 1
ISSUE DATE	11 December 2014	



RUBYCON CORPORATION
ENGINEERING DIVISION

1938-1, NISHIMINOWA, INA-SHI, NAGANO-KEN, JAPAN
TEL No. 0265-72-7116
FAX No. 0265-73-3380

DESIGN	KENTARO SEGI
	<i>Kentaro Segi</i>
CHECK	TAKESHI KOBAYASHI
	<i>T. Kobayashi</i>
APPROVAL	HIROKAZU KOUMURA
	<i>H. Koumura</i>

1. Scope.

This specification covers polarized aluminum electrolytic capacitors with non-solid electrolyte for use in electronic equipments .

2. Reference Standard

JIS C 5141 (1991) and JIS C 5102 (1994) methods for testing.

3. Operating Temperature Range

-40°C to +105°C

4. Performance Refer to Table-1

5. Style and Numbering System

(1) Style CE 04 (Radial Leaded)

(2) Numbering System	Rated Voltage	Series	Nominal Capacitance	Tolerance	Option	Lead Forming	Case size
	□□□	YXF	□□□	M	FFC	□□	□□□ X □□□

6. Marking

Unless otherwise specified, capacitor shall be clearly marked the following items on its body.

Sleeve color: Black

Lettering color: White

(1) Trade mark

Rubycon

(2) Rated Voltage

V

(3) Nominal Capacitance

μF

(4) Polarity

 (Negative Polarity)

(5) Series

YXF

(6) Date code

(7) Maximum Operating Temperature

105°C

(8) PET Sleeve mark

PET

7. Vent

On capacitors whose diameter is 6.3mm and greater, a safety vent shall be provided.

8. Notes on use of aluminum electrolytic capacitors

(1) Charge and discharge

Do not use for the circuit that repeats quick charge or discharge.

(2) External stress

Do not apply excessive force of pushing, pulling bending, and/or twisting to the main body, lead wire and terminals.

(3) Heat resistance at soldering process

In the soldering process of PC board with Capacitors mounted, secondary shrinkage or crack of sleeve may be observed when soldering temperature is too high and /or soldering time is too long.

If lead wire of other components or pattern of double sided PC board touches the capacitor, the similar failure may be also originated at pre-heating, heating at hardening process of adhesive and soldering process.

(4) Insulation and PC board mounting

Sleeve is for marking purpose only.

It is not recognized as insulation materials.

When double sided PC board is employed, note that it could cause a short circuit if lead wire of other components or pattern of double sided PC board touches capacitor. Please avoid circuit pattern runs underneath capacitor.

In addition, case and cathode terminal are not insulated.

(5) Adhesives and coating materials

Do not use the adhesives and coating materials that contain halogenated organic solvents or chloroprene as polymer.

YXF SERIES

Rubycon
RUBYCON CORPORATION

(6) Storage

Keep at a normal temperature and humidity. During a long storage time, leakage current will be increased. To prevent heat rise or any trouble that high leakage current possibly causes, voltage treatment is recommended for the capacitors that have been stored for a long time.

<Storage Condition>

*Aluminum electrolytic capacitors should not be stored in high temperatures or where there is a high level of humidity. The suitable storage condition is 5°C-35°C and less than 75% in relative humidity.

*Aluminum electrolytic capacitors should not be stored in damp conditions such as water, saltwater spray or oil spray.

*Do not store aluminum electrolytic capacitors in an environment full of hazardous gas (hydrogen sulfide, sulfurous acid gas, nitrous acid, chlorine gas, ammonia or bromine gas).

*Aluminum electrolytic capacitors should not be stored under exposure to ozone, ultraviolet rays or radiation.

(7) Fumigation and halogenated flame retardant

It may cause corrosion of internal electrodes, aluminum cases and terminal surface when the following conditions exist.

*Fumigation of wooden pallets before shipment to disinfect vermin.

*Existence of components or parts that contain halogenated flame retardant agent (bromine etc.) together with capacitors.

*When halogenated detergents of antiseptics for preventing infection of epidemic diseases contact directly to capacitors.

(8) PC board cleaning after soldering

Please consult us when cleaning is subjected.

◆ Guide to application except the above are described in our catalog and EIAJ RCR-2367C.

EIAJ RCR-2367C : " Safety Application Guide for fixed aluminum electrolytic capacitors for use in electronic equipment."

Published by Japan Electronics and Information Technology Industries Association.

◆ Table-1 PERFORMANCE

ITEMS		PERFORMANCE																										
1	Rated Voltage(WV) Surge Voltage (SV)	<table border="1"> <tr> <td>WV(V.DC)</td> <td>6.3</td> <td>10</td> <td>16</td> <td>25</td> <td>35</td> <td>50</td> <td>63</td> <td>100</td> </tr> <tr> <td>SV(V.DC)</td> <td>8</td> <td>13</td> <td>20</td> <td>32</td> <td>44</td> <td>63</td> <td>79</td> <td>125</td> </tr> </table>									WV(V.DC)	6.3	10	16	25	35	50	63	100	SV(V.DC)	8	13	20	32	44	63	79	125
WV(V.DC)	6.3	10	16	25	35	50	63	100																				
SV(V.DC)	8	13	20	32	44	63	79	125																				
2	Nominal Capacitance (Tolerance)	<Criteria> 1 to 15000 μ F(\pm 20%) <Condition> Measuring Frequency : 120Hz \pm 20% Measuring Voltage : Not more than 0.5Vrms + 1.5 to 2.0V.DC Measuring Temperature : 20 \pm 2 $^{\circ}$ C																										
3	Leakage Current	<Condition> The rated voltage shall be applied between terminals of capacitor such that the terminal voltage will reach the rated voltage within one minute and the leakage current shall be measured at 2 minutes after the voltage has reached the rated voltage across a 1000 \pm 10 Ω series protection resistor. Then the current value shall not exceed value calculated from following formula. <Criteria> $I=0.01CV$ or 3 μ A whichever is greater where I : Leakage current in μ A. C : Nominal capacitance in μ F. V : Rated voltage in V.DC.																										
4	Dissipation Factor (tan δ :Tangent of loss angle)	<Criteria> <table border="1"> <tr> <td>WV(V.DC)</td> <td>6.3</td> <td>10</td> <td>16</td> <td>25</td> <td>35</td> <td>50</td> <td>63</td> <td>100</td> </tr> <tr> <td>tanδ</td> <td>0.22</td> <td>0.19</td> <td>0.16</td> <td>0.14</td> <td>0.12</td> <td>0.10</td> <td>0.09</td> <td>0.08</td> </tr> </table> When nominal capacitance is over 1000 μ F, tan δ shall be added 0.02 to the listed value with increase of every 1000 μ F. <Condition> See ITEM 2, Nominal Capacitance, for measuring frequency, voltage and temperature.									WV(V.DC)	6.3	10	16	25	35	50	63	100	tan δ	0.22	0.19	0.16	0.14	0.12	0.10	0.09	0.08
WV(V.DC)	6.3	10	16	25	35	50	63	100																				
tan δ	0.22	0.19	0.16	0.14	0.12	0.10	0.09	0.08																				

5	Terminal Strength	<p><Condition> Tensile Strength of Terminals The body of capacitor shall be fixed and the tensile force of following table shall be applied to the terminal in lead out direction of the terminal for 10±1 seconds.</p> <p>Bending Strength of Terminals The body of capacitor shall be held in such a way that the regular lead-out axis of lead wire terminal becomes vertical. The weight of following table shall be suspended from the end of terminal. In this condition, after the body of sample is bent through 90 degrees, it shall be returned to the original position. Next the body shall be reversibly bent through 90 degrees and again returned to the original position.</p> <table border="1" data-bbox="531 595 1310 719"> <thead> <tr> <th>Diameter of lead wire</th> <th>Tensile force N{kgf}</th> <th>Bending force N{kgf}</th> </tr> </thead> <tbody> <tr> <td>0.5mm and less</td> <td>5{0.51}</td> <td>2.5{0.25}</td> </tr> <tr> <td>Over 0.5mm to 0.8mm incl</td> <td>10{1.0}</td> <td>5 {0.51}</td> </tr> </tbody> </table> <p><Criteria> Notable changes shall not be found, as breakage or looseness in the terminal.</p>	Diameter of lead wire	Tensile force N{kgf}	Bending force N{kgf}	0.5mm and less	5{0.51}	2.5{0.25}	Over 0.5mm to 0.8mm incl	10{1.0}	5 {0.51}																																																								
Diameter of lead wire	Tensile force N{kgf}	Bending force N{kgf}																																																																	
0.5mm and less	5{0.51}	2.5{0.25}																																																																	
Over 0.5mm to 0.8mm incl	10{1.0}	5 {0.51}																																																																	
6	Temperature Coefficient and Drift	<p><Condition></p> <table border="1" data-bbox="544 869 1345 1189"> <thead> <tr> <th>STEP</th> <th>Testing Temperature (°C)</th> <th>Time</th> </tr> </thead> <tbody> <tr> <td>1</td> <td>20±2</td> <td>Time to reach thermal equilibrium</td> </tr> <tr> <td>2</td> <td>-40±3</td> <td>//</td> </tr> <tr> <td>3</td> <td>-25±3</td> <td>//</td> </tr> <tr> <td>4</td> <td>20±2</td> <td>//</td> </tr> <tr> <td>5</td> <td>105±2</td> <td>2 hrs.</td> </tr> <tr> <td>6</td> <td>20±2</td> <td>Time to reach thermal equilibrium</td> </tr> </tbody> </table> <p>Capacitance, D.F. and Impedance shall be measured at 120Hz.</p> <p><Criteria></p> <table border="1" data-bbox="544 1274 1477 1534"> <tbody> <tr> <td>STEP 2,3</td> <td>Impedance Ratio</td> <td>The value of ratio to STEP 1 not more than value of following table.</td> </tr> <tr> <td rowspan="3">STEP 5</td> <td>Capacitance Change</td> <td>Within ±25% of the value of STEP 1</td> </tr> <tr> <td>Dissipation Factor</td> <td>Not more than the specified value</td> </tr> <tr> <td>Leakage Current</td> <td>Not more than 8 times the specified value</td> </tr> <tr> <td rowspan="3">STEP 6</td> <td>Capacitance Change</td> <td>Within ±10% of the value of STEP 1</td> </tr> <tr> <td>Dissipation Factor</td> <td>Not more than the specified value</td> </tr> <tr> <td>Leakage Current</td> <td>Not more than the specified value</td> </tr> </tbody> </table> <table border="1" data-bbox="531 1561 1275 1693"> <thead> <tr> <th>WV(V.DC)</th> <th>6.3</th> <th>10</th> <th>16</th> <th>25</th> <th>35</th> <th>50</th> <th>63</th> <th>100</th> </tr> </thead> <tbody> <tr> <td>Z(-25°C)/Z(+20°C)</td> <td>4</td> <td>3</td> <td>2</td> <td>2</td> <td>2</td> <td>2</td> <td>2</td> <td>2</td> </tr> <tr> <td>Z(-40°C)/Z(+20°C)</td> <td>8</td> <td>6</td> <td>4</td> <td>3</td> <td>3</td> <td>3</td> <td>3</td> <td>3</td> </tr> </tbody> </table>	STEP	Testing Temperature (°C)	Time	1	20±2	Time to reach thermal equilibrium	2	-40±3	//	3	-25±3	//	4	20±2	//	5	105±2	2 hrs.	6	20±2	Time to reach thermal equilibrium	STEP 2,3	Impedance Ratio	The value of ratio to STEP 1 not more than value of following table.	STEP 5	Capacitance Change	Within ±25% of the value of STEP 1	Dissipation Factor	Not more than the specified value	Leakage Current	Not more than 8 times the specified value	STEP 6	Capacitance Change	Within ±10% of the value of STEP 1	Dissipation Factor	Not more than the specified value	Leakage Current	Not more than the specified value	WV(V.DC)	6.3	10	16	25	35	50	63	100	Z(-25°C)/Z(+20°C)	4	3	2	2	2	2	2	2	Z(-40°C)/Z(+20°C)	8	6	4	3	3	3	3	3
STEP	Testing Temperature (°C)	Time																																																																	
1	20±2	Time to reach thermal equilibrium																																																																	
2	-40±3	//																																																																	
3	-25±3	//																																																																	
4	20±2	//																																																																	
5	105±2	2 hrs.																																																																	
6	20±2	Time to reach thermal equilibrium																																																																	
STEP 2,3	Impedance Ratio	The value of ratio to STEP 1 not more than value of following table.																																																																	
STEP 5	Capacitance Change	Within ±25% of the value of STEP 1																																																																	
	Dissipation Factor	Not more than the specified value																																																																	
	Leakage Current	Not more than 8 times the specified value																																																																	
STEP 6	Capacitance Change	Within ±10% of the value of STEP 1																																																																	
	Dissipation Factor	Not more than the specified value																																																																	
	Leakage Current	Not more than the specified value																																																																	
WV(V.DC)	6.3	10	16	25	35	50	63	100																																																											
Z(-25°C)/Z(+20°C)	4	3	2	2	2	2	2	2																																																											
Z(-40°C)/Z(+20°C)	8	6	4	3	3	3	3	3																																																											

7	Load Life Test	<p><Condition> Capacitor under the test shall be applied the rated voltage continuously through 1000 Ω series protective resistor (with maximum ripple current) at 105±2°C for following test period. After the test and returned in standard condition for 1 to 2 hours, and the capacitor shall meet following requirements.</p> <table border="1" data-bbox="533 450 1139 719"> <thead> <tr> <th rowspan="2">Case dia.</th> <th colspan="2">Life time</th> </tr> <tr> <th>6.3 to 10WV</th> <th>16 to 100WV</th> </tr> </thead> <tbody> <tr> <td>≤φ6.3</td> <td>4000 ⁺⁷²₀</td> <td>5000 ⁺⁷²₀</td> </tr> <tr> <td>φ8, φ10</td> <td>6000 ⁺⁷²₀</td> <td>7000 ⁺⁷²₀</td> </tr> <tr> <td>φ12.5≤</td> <td>8000 ⁺⁷²₀</td> <td>10000 ⁺⁷²₀</td> </tr> </tbody> </table> <p><Criteria></p> <table border="1" data-bbox="533 768 1441 918"> <tr> <td>Leakage Current</td> <td>Not more than the specified value</td> </tr> <tr> <td>Capacitance Change</td> <td>Within ±25% of the initial value</td> </tr> <tr> <td>Dissipation Factor</td> <td>Not more than 200% of the specified value</td> </tr> <tr> <td>Appearance</td> <td>Notable changes shall not be found, except sleeve</td> </tr> </table>	Case dia.	Life time		6.3 to 10WV	16 to 100WV	≤φ6.3	4000 ⁺⁷² ₀	5000 ⁺⁷² ₀	φ8, φ10	6000 ⁺⁷² ₀	7000 ⁺⁷² ₀	φ12.5≤	8000 ⁺⁷² ₀	10000 ⁺⁷² ₀	Leakage Current	Not more than the specified value	Capacitance Change	Within ±25% of the initial value	Dissipation Factor	Not more than 200% of the specified value	Appearance	Notable changes shall not be found, except sleeve
Case dia.	Life time																							
	6.3 to 10WV	16 to 100WV																						
≤φ6.3	4000 ⁺⁷² ₀	5000 ⁺⁷² ₀																						
φ8, φ10	6000 ⁺⁷² ₀	7000 ⁺⁷² ₀																						
φ12.5≤	8000 ⁺⁷² ₀	10000 ⁺⁷² ₀																						
Leakage Current	Not more than the specified value																							
Capacitance Change	Within ±25% of the initial value																							
Dissipation Factor	Not more than 200% of the specified value																							
Appearance	Notable changes shall not be found, except sleeve																							
8	Shelf Life Test	<p><Condition> Capacitors shall be stored at 105±2°C with no voltage applied for 1000 ⁺⁴⁸₀ hours. After the test and returned in standard condition for 1 to 2 hours and the capacitor shall meet following requirements. (If any doubt arises on the judgment, the capacitors shall be subjected to voltage treatment specified in JIS C 5141,5.2.)</p> <p><Criteria></p> <table border="1" data-bbox="533 1171 1445 1319"> <tr> <td>Leakage Current</td> <td>Not more than the specified value</td> </tr> <tr> <td>Capacitance Change</td> <td>Within ±25% of the initial value</td> </tr> <tr> <td>Dissipation Factor</td> <td>Not more than 200% of the specified value</td> </tr> <tr> <td>Appearance</td> <td>Notable changes shall not be found</td> </tr> </table>	Leakage Current	Not more than the specified value	Capacitance Change	Within ±25% of the initial value	Dissipation Factor	Not more than 200% of the specified value	Appearance	Notable changes shall not be found														
Leakage Current	Not more than the specified value																							
Capacitance Change	Within ±25% of the initial value																							
Dissipation Factor	Not more than 200% of the specified value																							
Appearance	Notable changes shall not be found																							
9	Surge Voltage	<p><Condition> Capacitor shall be applied the surge voltage through a (100±50)/C_R [kΩ] resistor in series for 30±5 seconds in every 6±0.5 minutes at 15 to 35°C. Procedure shall be repeated 1000 times. Then the capacitors shall be left under normal humidity for 1 to 2 hours before measurement. [C_R : Nominal Capacitance (μF)]</p> <p><Criteria></p> <table border="1" data-bbox="533 1547 1445 1695"> <tr> <td>Leakage Current</td> <td>Not more than the specified value</td> </tr> <tr> <td>Capacitance Change</td> <td>Within ±15% of the initial value</td> </tr> <tr> <td>Dissipation Factor</td> <td>Not more than the specified value</td> </tr> <tr> <td>Appearance</td> <td>Notable changes shall not be found</td> </tr> </table> <p>◇This test simulates overvoltage at abnormal situations, and not be hypothesizing that overvoltage is always applied.</p>	Leakage Current	Not more than the specified value	Capacitance Change	Within ±15% of the initial value	Dissipation Factor	Not more than the specified value	Appearance	Notable changes shall not be found														
Leakage Current	Not more than the specified value																							
Capacitance Change	Within ±15% of the initial value																							
Dissipation Factor	Not more than the specified value																							
Appearance	Notable changes shall not be found																							

10	Vibration Test	<p><Condition> Testing shall be done out in 3 AXIS for 2 hours each (total 6 hours) as below. Fix lead wire at a point not more than 4mm from the body , use mounting device separately for the one with a diameter 12.5mm and greater or with a length 25mm and longer.</p> <p>(Vibration frequency range : 10 to 55Hz Peak to peak amplitude : 1.5mm Sweep rate : 10 to 55 to 10Hz, In about 1min.)</p> <p><Criteria></p> <table border="1" data-bbox="533 546 1268 719"> <tr> <td>Capacitance (During test)</td> <td>Measured value shall be stable. (The time from one end to the other of the vibration frequency within last 30 minutes at last direction.)</td> </tr> <tr> <td>Capacitance Change</td> <td>Within $\pm 5\%$ of the initial value</td> </tr> <tr> <td>Appearance</td> <td>Notable changes shall not be found</td> </tr> </table>	Capacitance (During test)	Measured value shall be stable. (The time from one end to the other of the vibration frequency within last 30 minutes at last direction.)	Capacitance Change	Within $\pm 5\%$ of the initial value	Appearance	Notable changes shall not be found		
Capacitance (During test)	Measured value shall be stable. (The time from one end to the other of the vibration frequency within last 30 minutes at last direction.)									
Capacitance Change	Within $\pm 5\%$ of the initial value									
Appearance	Notable changes shall not be found									
11	Solderability	<p><Condition> Terminals of the capacitor shall be immersed in flux (ethanol solution of the rosin, 25 wt% rosin) for 5 to 10 seconds and shall be immersed in the solder bath ($235\pm 5^{\circ}\text{C}$) and held for 2 ± 0.5 seconds, and pulled out at the same speed.</p> <p><Criteria> At least $3/4$ of circumferential surface of dipped portion of the terminal shall be covered with new solder.</p>								
12	Resistance to Solder Heat	<p><Condition> Terminals of the capacitor shall be immersed into solder bath at $260\pm 5^{\circ}\text{C}$ for 10 ± 1 seconds up to 1.5 to 2.0mm from the body of capacitor. Then the capacitors shall be left under the normal temperature and normal humidity for 1 to 2 hours before measurement.</p> <p><Criteria></p> <table border="1" data-bbox="533 1196 1445 1341"> <tr> <td>Leakage Current</td> <td>Not more than the specified value</td> </tr> <tr> <td>Capacitance Change</td> <td>Within $\pm 10\%$ of the initial value</td> </tr> <tr> <td>Dissipation Factor</td> <td>Not more than the specified value</td> </tr> <tr> <td>Appearance</td> <td>Notable changes shall not be found</td> </tr> </table>	Leakage Current	Not more than the specified value	Capacitance Change	Within $\pm 10\%$ of the initial value	Dissipation Factor	Not more than the specified value	Appearance	Notable changes shall not be found
Leakage Current	Not more than the specified value									
Capacitance Change	Within $\pm 10\%$ of the initial value									
Dissipation Factor	Not more than the specified value									
Appearance	Notable changes shall not be found									
13	Resistance to Damp Heat (Steady State)	<p><Condition> Capacitor shall be stored in the ambient of $40\pm 2^{\circ}\text{C}$ and relative humidity 90 to 95% for 240 ± 8 hours. Then the capacitors shall be left under the normal temperature and normal humidity for 1 to 2 hours before measurement.</p> <p><Criteria></p> <table border="1" data-bbox="533 1543 1445 1688"> <tr> <td>Leakage Current</td> <td>Not more than the specified value</td> </tr> <tr> <td>Capacitance Change</td> <td>Within $\pm 15\%$ of the initial value</td> </tr> <tr> <td>Dissipation Factor</td> <td>Not more than the specified value</td> </tr> <tr> <td>Appearance</td> <td>Notable changes shall not be found</td> </tr> </table>	Leakage Current	Not more than the specified value	Capacitance Change	Within $\pm 15\%$ of the initial value	Dissipation Factor	Not more than the specified value	Appearance	Notable changes shall not be found
Leakage Current	Not more than the specified value									
Capacitance Change	Within $\pm 15\%$ of the initial value									
Dissipation Factor	Not more than the specified value									
Appearance	Notable changes shall not be found									

14 Maximum Permissible Ripple Current

- (1)The maximum permissible ripple current is the maximum A.C. current at 100kHz and can be applied at maximum operating temperature.
 (2)The combined value of D.C. voltage and the peak A.C. voltage shall not exceed the rated voltage and shall not be reverse voltage.

<Frequency Coefficient>

Frequency(Hz) \ Capacitance(μ F)	120	1k	10k	100k \leq
1 to 10	0.42	0.60	0.80	1.00
22 to 33	0.55	0.75	0.90	1.00
47 to 330	0.70	0.85	0.95	1.00
470 to 1000	0.75	0.90	0.98	1.00
2200 to 15000	0.80	0.95	1.00	1.00

< Temperature Coefficient >

Ambient Temperature($^{\circ}$ C)	105	85	65 \geq
Coefficient	1.0	1.7	2.1

◇Temperature coefficient shows a limit of ripple current exceeding the rated ripple current that can be passed through a capacitor at each temperature when the life expectancy of a capacitor becomes to be nearly equal with the lifetime at the rated maximum operating temperature.

◇Use of aluminum electrolytic capacitor under ripple voltage with wide amplitude is equivalent to quick charge-discharge operation.

When ripple voltage with the amplitude over 70Vp-p is expected for the products with rated voltage over 100V, please contact us.

9. Diagram of dimensions. :unit mm

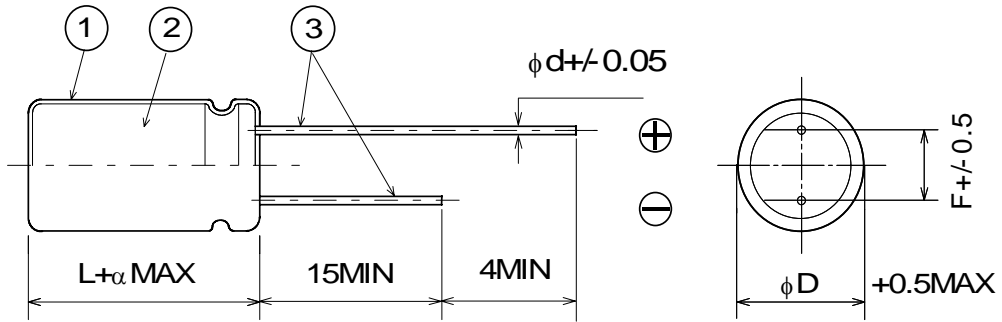

◆Table-2

ϕD	5	6.3	8	10	12.5	16	18
F	2.0	2.5	3.5	5.0	5.0	7.5	7.5
ϕd	0.5	0.5	0.6	0.6	0.6	0.8	0.8
α	L≤16 : $\alpha=1.5$		L≥20 : $\alpha=2.0$				

◆Table-3

①	Sleeve	P.E.T.
②	Case	Aluminum
③	Lead Wire	Tin plated

◆ Table-4 Standard size, Maximum permissible ripple current and Impedance

Rated voltage 6.3V				
Nominal capacitance (μ F)	Size ϕ DxL(mm)	Ripple Current (mA r.m.s./105°C,100kHz)	Impedance (Ω MAX)	
			20°C,100kHz	-10°C,100kHz
100	5X11	150	0.90	3.6
220	6.3X11	250	0.40	1.6
330	6.3X11	250	0.40	1.6
470	8X11.5	400	0.25	1.0
1000	10X12.5	580	0.16	0.65
2200	12.5X20	1300	0.062	0.21
3300	12.5X20	1300	0.062	0.21
4700	16X25	1850	0.034	0.096
6800	16X25	1850	0.034	0.096
10000	16X31.5	2000	0.029	0.087
15000	18X35.5	2200	0.025	0.058

Rated voltage 10V				
Nominal capacitance (μ F)	Size ϕ DxL(mm)	Ripple Current (mA r.m.s./105°C,100kHz)	Impedance (Ω MAX)	
			20°C,100kHz	-10°C,100kHz
100	5X11	150	0.90	3.6
220	6.3X11	250	0.40	1.6
330	8X11.5	400	0.25	1.0
470	8X11.5	400	0.25	1.0
1000	10X16	770	0.12	0.46
2200	12.5X20	1300	0.062	0.21
3300	12.5X25	1650	0.048	0.16
4700	16X25	1850	0.034	0.096
6800	16X31.5	2000	0.029	0.087
10000	18X35.5	2200	0.025	0.058

Rated voltage 16V				
Nominal capacitance (μ F)	Size ϕ DxL(mm)	Ripple Current (mA r.m.s./105°C,100kHz)	Impedance (Ω MAX)	
			20°C,100kHz	-10°C,100kHz
47	5X11	150	0.90	3.6
100	6.3X11	250	0.40	1.6
220	8X11.5	400	0.25	1.0
330	8X11.5	400	0.25	1.0
470	10X12.5	580	0.16	0.65
1000	10X20	1050	0.078	0.30
2200	12.5X25	1650	0.048	0.16
3300	16X25	1850	0.034	0.096
4700	16X31.5	2000	0.029	0.087
6800	18X35.5	2200	0.025	0.058

Rated voltage 25V				
Nominal capacitance (μ F)	Size ϕ DxL(mm)	Ripple Current (mA r.m.s./105°C,100kHz)	Impedance (Ω MAX)	
			20°C,100kHz	-10°C,100kHz
33	5X11	150	0.90	3.6
47	5X11	150	0.90	3.6
100	6.3X11	250	0.40	1.6
220	8X11.5	400	0.25	1.0
330	10X12.5	580	0.16	0.65
470	10X16	770	0.12	0.46
1000	12.5X20	1300	0.062	0.21
2200	16X25	1850	0.034	0.096
3300	16X31.5	2000	0.029	0.087
4700	18X35.5	2200	0.025	0.058

Rated voltage 35V				
Nominal capacitance (μ F)	Size ϕ DxL(mm)	Ripple Current (mA r.m.s./105°C,100kHz)	Impedance (Ω MAX)	
			20°C,100kHz	-10°C,100kHz
33	5X11	150	0.90	3.6
47	6.3X11	250	0.40	1.6
100	8X11.5	400	0.25	1.0
220	10X12.5	580	0.16	0.65
330	10X16	770	0.12	0.46
470	10X20	1050	0.078	0.30
1000	12.5X25	1650	0.048	0.16
2200	16X31.5	2000	0.029	0.087
3300	18X35.5	2200	0.025	0.058

YXF SERIES

Rubycon
RUBYCON CORPORATION

Rated voltage 50V				
Nominal capacitance (μ F)	Size ϕ DxL(mm)	Ripple Current (mA r.m.s./105°C,100kHz)	Impedance (Ω MAX)	
			20°C,100kHz	-10°C,100kHz
1	5X11	30	4.0	8.0
2.2	5X11	43	2.5	6.0
3.3	5X11	53	2.2	5.6
4.7	5X11	88	1.9	5.0
10	5X11	100	1.5	4.0
22	5X11	150	0.90	3.6
33	6.3X11	250	0.40	1.6
47	6.3X11	250	0.40	1.6
100	8X11.5	400	0.25	1.0
220	10X16	770	0.12	0.46
330	10X20	1050	0.078	0.30
470	12.5X20	1300	0.062	0.21
1000	16X25	1850	0.034	0.096
2200	18X35.5	2200	0.025	0.058

Rated voltage 63V				
Nominal capacitance (μ F)	Size ϕ DxL(mm)	Ripple Current (mA r.m.s./105°C,100kHz)	Impedance (Ω MAX)	
			20°C,100kHz	-10°C,100kHz
10	5X11	87	2.3	9.3
22	6.3X11	140	1.3	5.2
33	6.3X11	140	1.2	5.0
47	8X11.5	210	0.63	2.8
100	10X12.5	300	0.43	1.8
220	10X20	520	0.21	0.84
330	12.5X20	660	0.16	0.64
470	12.5X25	750	0.12	0.45
1000	16X31.5	1390	0.054	0.20

Rated voltage 100V				
Nominal capacitance (μ F)	Size ϕ DxL(mm)	Ripple Current (mA r.m.s./105°C,100kHz)	Impedance (Ω MAX)	
			20°C,100kHz	-10°C,100kHz
1	5X11	20	4.5	15.0
2.2	5X11	30	3.0	13.0
3.3	5X11	40	2.7	11.0
4.7	5X11	65	2.5	10.0
10	6.3X11	140	1.2	5.0
22	8X11.5	160	0.63	2.8
33	10X12.5	230	0.43	1.8
47	10X16	290	0.31	1.5
100	12.5X20	430	0.16	0.64
220	16X25	900	0.073	0.27
330	16X25	900	0.073	0.27

YXF SERIES

Rubycon
RUBYCON CORPORATION

X-ON Electronics

Largest Supplier of Electrical and Electronic Components

Click to view similar products for [Aluminium Electrolytic Capacitors - Radial Leaded](#) category:

Click to view products by [Rubycon](#) manufacturer:

Other Similar products are found below :

[LXY50VB4.7M-5X11](#) [RFO-100V471MJ7P#](#) [ECE-A1EGE220](#) [B41041A7226M8](#) [B41044A7157M6](#) [NCD681K10KVY5PF](#)

[NEV1000M25EF-BULK](#) [NEV100M35DC](#) [NEV100M63DE](#) [NEV220M25DD-BULK](#) [NEV.33M100AA](#) [NEV4700M50HB](#) [NEV.47M100AA](#)

[NEVH1.0M250AB](#) [NEVH3.3M250BB](#) [NEVH3.3M450CC](#) [KME50VB100M-8X11.5](#) [SG220M1CSA-0407](#) [ES5107M016AE1DA](#)

[ESMG160ETD102MJ16S](#) [ESX472M16B](#) [227RZS050M](#) [476CKH100MSA](#) [477RZS050M](#) [B41793A9108Q1](#) [UVX1V101KPA1FA](#)

[UVX1V222MHA1CA](#) [KME25VB100M-6.3X11](#) [VTL100S10](#) [VTL470S10](#) [VTL470S16A](#) [511D336M250EK5D](#) [052687X](#) [ECE-A1CF471](#)

[NRE-S560M16V6.3X7TBSTF](#) [RGA221M1CTA-0611G](#) [ERZA630VHN182UP54N](#) [UPL1A331MPH](#) [NEV1000M6.3DE](#) [NEV100M16CB](#)

[NEV100M50DD-BULK](#) [NEV2200M16FF](#) [NEV220M50EE](#) [NEV2.2M50AA](#) [NEV330M63EF](#) [NEV4700M35HI](#) [NEV4.7M100BA](#)

[NEV47M16BA](#) [NEV47M50CB-BULK](#) [NEVH1.0M350AB](#)