

Messrs.
Techtronic Industries Co. Ltd. (TTI)
Milwaukee Electric Tool Corp.

ALUMINUM ELECTROLYTIC CAPACITORS SPECIFICATION SHEET

RoHS Compliance

CUSTOMER PART No.		
Rubycon PART No.	35 ZLH 220 M TTI T7 8X11.5	
DRAWING No.	RER-211701	ISSUE No.1
ISSUE DATE	05 February 2021	



RUBYCON CORPORATION
ENGINEERING DIVISION

1938-1, NISHIMINOWA, INA-SHI, NAGANO-KEN, JAPAN
TEL No. 0265-72-7116
FAX No. 0265-73-3380

DESIGN	YOSHIHIRO KITAHARA
	<i>y. Kitahara</i>
CHECK	YUSUKE MATSUZAKI
	<i>y. Matsuzaki</i>
APPROVAL	YOSHINORI SASAKI
	<i>Y. Sasaki</i>

1.Scope

This specification covers polarized aluminum electrolytic capacitors with non-solid electrolyte for use in electronic equipments.
Style: CE 04 (Radial Leaded)

2.Numbering System

Rated Voltage	Series	Capacitance	Capacitance Tolerance	Option	Lead Forming	Size
<u>35</u>	<u>ZLH</u>	<u>220</u>	<u>M</u>	<u>TTI</u>	<u>□□</u>	<u>8X11.5</u>

3.Diagram of dimensions Unit : mm

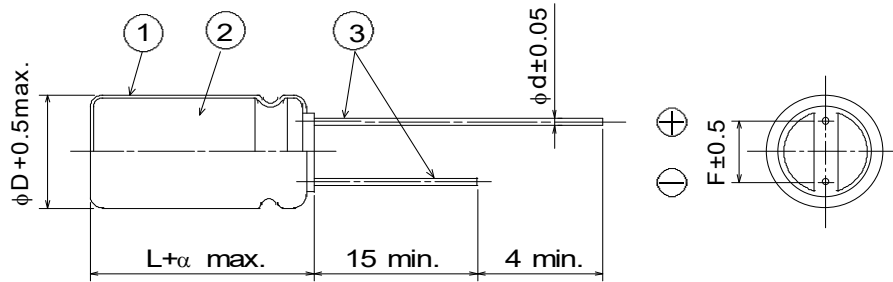

Dimensions				
φD	L	F	φd	α
8	11.5	3.5	0.6	1.5

①	Sleeve	P.E.T.	
②	Case	Aluminum	
③	Lead Wire	Copper clad steel wire	Tin plated

A safety vent shall be provided.

4.Marking

Unless otherwise specified, capacitor shall be clearly marked the following items on its body.

Sleeve color: Black, Lettering color: White

(1)Trade mark	Rubycon
(2)Rated Voltage	35V
(3)Nominal Capacitance	220μF
(4)Polarity	 (Negative Polarity)
(5)Series	ZLH
(6)Lot Number	
(7)Maximum Operating Temperature	105°C
(8)PET sleeve mark	PET

5.Electrical Performance

Table-1

Operating Temperature Range	-40 ~105	(°C)
Nominal Capacitance	20°C, 120Hz	220 (μF)
Capacitance Tolerance	-20 ~ 20	(%)
Rated Voltage	35	(V.DC)
Surge Voltage	44	(V.DC)
Leakage Current	20°C, 2min.	77 (μA max.)
Dissipation Factor (tanδ)	20°C, 120Hz	0.12 (max.)
Rated Ripple Current	105°C, 100kHz	945 (mAr.m.s.)
Impedance Ratio	120Hz Z-25°C/Z20°C	2 (max.)
	Z-40°C/Z20°C	3 (max.)
Impedance	20°C, 100kHz	0.056 (Ωmax.)
	-10°C, 100kHz	0.19 (Ωmax.)

6. PERFORMANCE

Table-2

1	Load Life Test	<p><Condition> Capacitor under the test shall be applied the rated voltage continuously through 1000Ω series protective resistor (with rated ripple current) at following temperature and time. After the test and returned in standard condition for 1 to 2 hours, and the capacitor shall meet following requirements.</p> <p style="text-align: center;">Temperature: 105 ±2°C Time: 8000 $\begin{smallmatrix} +72 \\ 0 \end{smallmatrix}$ h</p> <p><Criteria></p> <table border="1" data-bbox="560 600 1465 745"> <tbody> <tr> <td>Leakage Current</td> <td>Not more than the specified value</td> </tr> <tr> <td>Capacitance Change</td> <td>Within ±25% of the initial value</td> </tr> <tr> <td>Dissipation Factor</td> <td>Not more than 200% of the specified value</td> </tr> <tr> <td>Appearance</td> <td>Notable changes shall not be found. (except sleeve Condition)</td> </tr> </tbody> </table>	Leakage Current	Not more than the specified value	Capacitance Change	Within ±25% of the initial value	Dissipation Factor	Not more than 200% of the specified value	Appearance	Notable changes shall not be found. (except sleeve Condition)											
Leakage Current	Not more than the specified value																				
Capacitance Change	Within ±25% of the initial value																				
Dissipation Factor	Not more than 200% of the specified value																				
Appearance	Notable changes shall not be found. (except sleeve Condition)																				
2	Shelf Life Test	<p><Condition> Capacitor shall be stored at following temperature and time with no voltage applied . After the test and returned in standard condition for 1 to 2 hours and the capacitor shall meet following requirements. (If any doubt arises on the judgment, the capacitors shall be subjected to voltage treatment specified in JIS C 5141,5.2.)</p> <p style="text-align: center;">Temperature: 105 ±2°C Time: 1000 $\begin{smallmatrix} +48 \\ 0 \end{smallmatrix}$ h</p> <p><Criteria></p> <table border="1" data-bbox="560 1077 1465 1223"> <tbody> <tr> <td>Leakage Current</td> <td>Not more than the specified value</td> </tr> <tr> <td>Capacitance Change</td> <td>Within ±25% of the initial value</td> </tr> <tr> <td>Dissipation Factor</td> <td>Not more than 200% of the specified value</td> </tr> <tr> <td>Appearance</td> <td>Notable changes shall not be found</td> </tr> </tbody> </table>	Leakage Current	Not more than the specified value	Capacitance Change	Within ±25% of the initial value	Dissipation Factor	Not more than 200% of the specified value	Appearance	Notable changes shall not be found											
Leakage Current	Not more than the specified value																				
Capacitance Change	Within ±25% of the initial value																				
Dissipation Factor	Not more than 200% of the specified value																				
Appearance	Notable changes shall not be found																				
3	Rated ripple current	<p>(1) The rated ripple current is the maximum A.C. current at 100kHz and can be applied at maximum operating temperature.</p> <p>(2) The combined value of D.C. voltage and the peak A.C. voltage shall not exceed the rated voltage and shall not be reverse voltage.</p> <p><Frequency Coefficient></p> <table border="1" data-bbox="459 1451 1126 1626"> <thead> <tr> <th>Frequency (Hz)</th> <th>120</th> <th>1k</th> <th>10k</th> <th>100k≤</th> </tr> </thead> <tbody> <tr> <th>Capacitance (μF)</th> <td>220</td> <td>0.5</td> <td>0.73</td> <td>0.92</td> <td>1</td> </tr> </tbody> </table> <p><Temperature Coefficient ></p> <table border="1" data-bbox="459 1693 1015 1771"> <tbody> <tr> <th>Temperature(°C)</th> <td>105</td> <td>85</td> <td>65≥</td> </tr> <tr> <th>Coefficient</th> <td>1.0</td> <td>1.7</td> <td>2.1</td> </tr> </tbody> </table> <p>◇Temperature coefficient shows a limit of ripple current exceeding the rated ripple current that can be passed through a capacitor at each temperature when the life expectancy of a capacitor becomes to be nearly equal with the lifetime at the rated maximum operating temperature.</p>	Frequency (Hz)	120	1k	10k	100k≤	Capacitance (μF)	220	0.5	0.73	0.92	1	Temperature(°C)	105	85	65≥	Coefficient	1.0	1.7	2.1
Frequency (Hz)	120	1k	10k	100k≤																	
Capacitance (μF)	220	0.5	0.73	0.92	1																
Temperature(°C)	105	85	65≥																		
Coefficient	1.0	1.7	2.1																		

7. Lead Terminal Requirement (No substitutions Allowed)

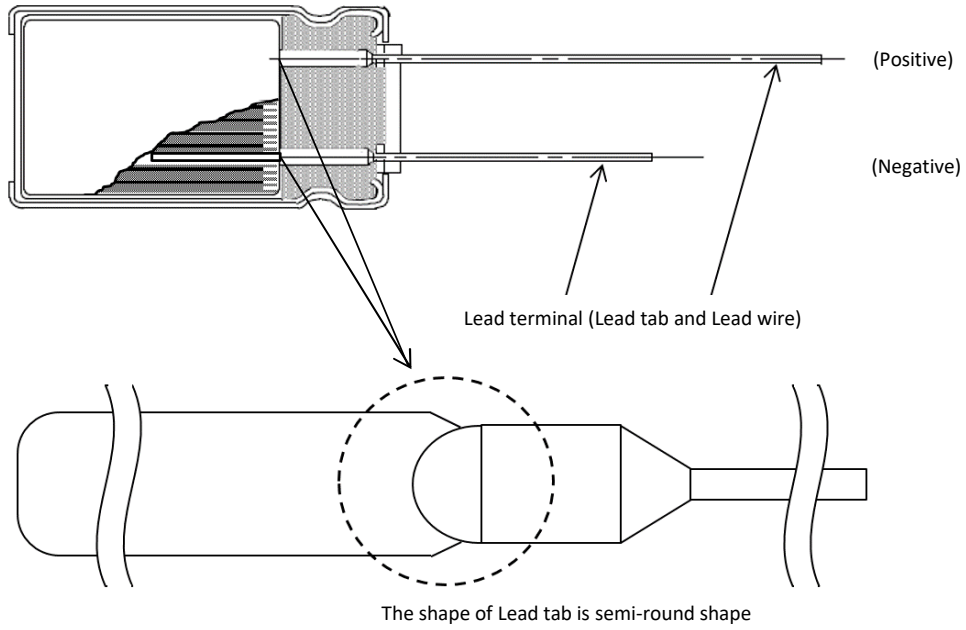

Notes on use of aluminum electrolytic capacitors

(1) Charge and discharge

Do not use for the circuit that repeats quick charge or discharge.

(2) External stress

Do not apply excessive force of pushing, pulling bending, and/or twisting to the main body, lead wire and terminals.

(3) Heat resistance at soldering process

In the soldering process of PC board with Capacitors mounted, secondary shrinkage or crack of sleeve may be observed when soldering temperature is too high and /or soldering time is too long.

If lead wire of other components or pattern of double sided PC board touches the capacitor, the similar failure may be also originated at pre-heating, heating at hardening process of adhesive and soldering process.

(4) Insulation and PC board mounting

Sleeve is for marking purpose only.

It is not recognized as insulation materials.

When double sided PC board is employed, note that it could cause a short circuit if lead wire of other components or pattern of double sided PC board touches capacitor. Please avoid circuit pattern runs underneath capacitor.

In addition, case and cathode terminal are not insulated.

(5) Adhesives and coating materials

Do not use the adhesives and coating materials that contain halogenated organic solvents or chloroprene as polymer.

(6) Storage

Keep at a normal temperature and humidity. During a long storage time, leakage current will be increased. To prevent heat rise or any trouble that high leakage current possibly causes, voltage treatment is recommended for the capacitors that have been stored for a long time.

(Storage Condition)

*Aluminum electrolytic capacitors should not be stored in high temperatures or where there is a high level of humidity. The suitable storage condition is 5°C-35°C and less than 75% in relative humidity.

*Aluminum electrolytic capacitors should not be stored in damp conditions such as water, saltwater spray or oil spray.

*Do not store aluminum electrolytic capacitors in an environment full of hazardous gas (hydrogen sulfide, sulfuric acid gas, nitrous acid, chlorine gas, ammonia or bromine gas).

*Aluminum electrolytic capacitors should not be stored under exposure to ozone, ultraviolet rays or radiation.

(7) Fumigation and halogenated flame retardant

It may cause corrosion of internal electrodes, aluminum cases and terminal surface when the following conditions exist.

*Fumigation of wooden pallets before shipment to disinfect vermin.

*Existence of components or parts that contain halogenated flame retardant agent (bromine etc.) together with capacitors.

*When halogenated detergents of antiseptics for preventing infection of epidemic diseases contact directly to capacitors.

(8) PC board cleaning after soldering

Please consult us when cleaning is subjected.

*Guide to application except the above are described in our catalog and JEITA RCR-2367D (including any amendments).

JEITA RCR-2367D : "Safety application guide for fixed aluminum electrolytic capacitors for use in electronic equipment."

Published by Japan Electronics and Information Technology Industries Association.

TAPING SPECIFICATION OF RADIAL LEAD TYPE ALUMINUM ELECTROLYTIC CAPACITORS

1.Scope

This specification covers taped radial lead type electrolytic capacitors, with case dia of $\phi 8$ mm.

2.Requirements.

2-1. Body tape requirements are shown in page 7.

2-2. All polarized capacitors must be oriented in one direction.

2-3. Leader tape shall be provided before the first capacitor and after the last one on tape at minimum length of 3 feed holes.

2-4 Maximum of 3 consecutive missing capacitors are permitted while one pack quantity meets the specification in para.4.

2-5. Mounting tape shall be spliced as shown in Fig.1. Mounting tape shall not be over lapped.

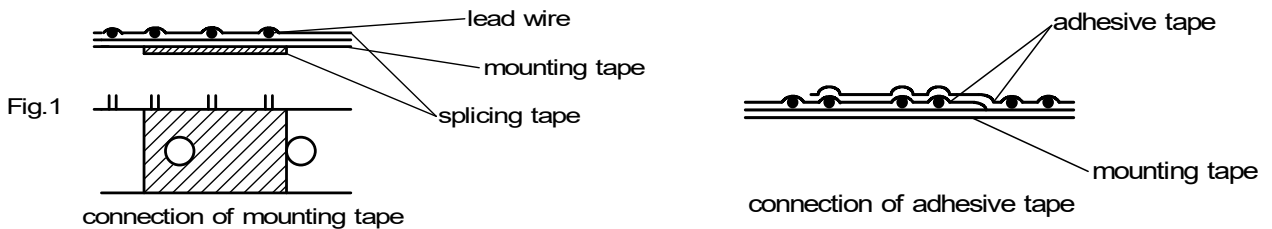

2-6. Defective capacitors shall be pulled out or clipped from the mounting tape.

Remaining protrusion of the leads shall not exceed 2mm from edge of the tape, when clipped.

3. Adhesion test of mounting tape

3-1. Adhesive tape on the mounting tape shall not a tear off at the force of less than 3N {0.3kgf} when tested in a manner shown in Fig.2.

3-2. Capacitors shall not be pulled out of the tape with a following load applied to the capacitor body in a manner shown in Fig.3.

Dia $\leq \phi 8$ mm 10N {1.0kgf}
Dia $\geq \phi 10$ mm 5N {0.5kgf}

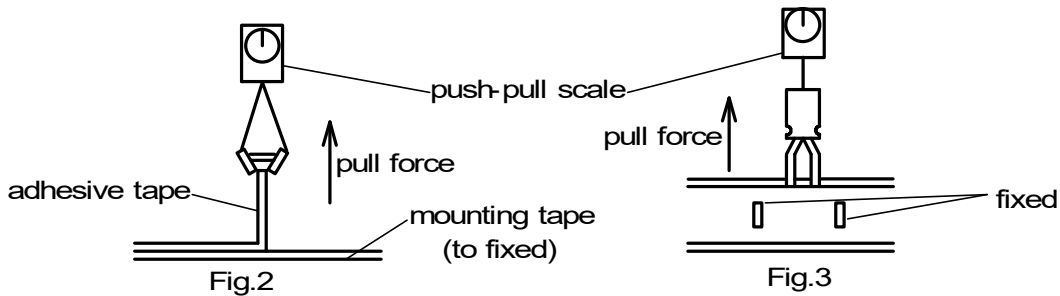

4.Package

Taped capacitors shall be packed in a carton shown in Fig.4, with tape ammunition.

Packed cartons shall be marked at least polarity, rated voltage, nominal capacitance and quantity.

On case dia $\phi 10\text{mm}$, $\phi 12.5\text{mm}$ and $\phi 16\text{mm}$, one capacitor shall be removed at each bend of the tape.

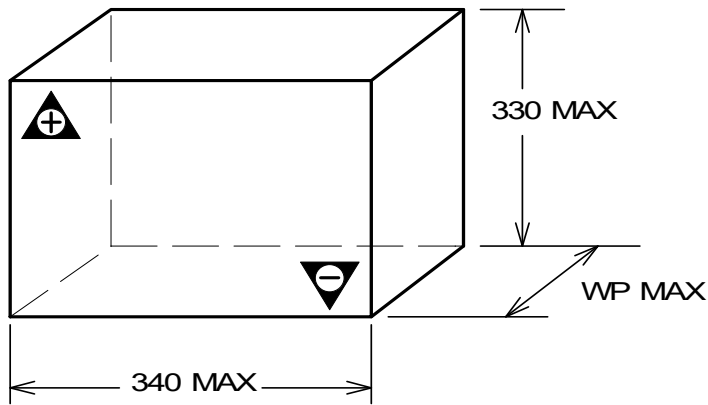
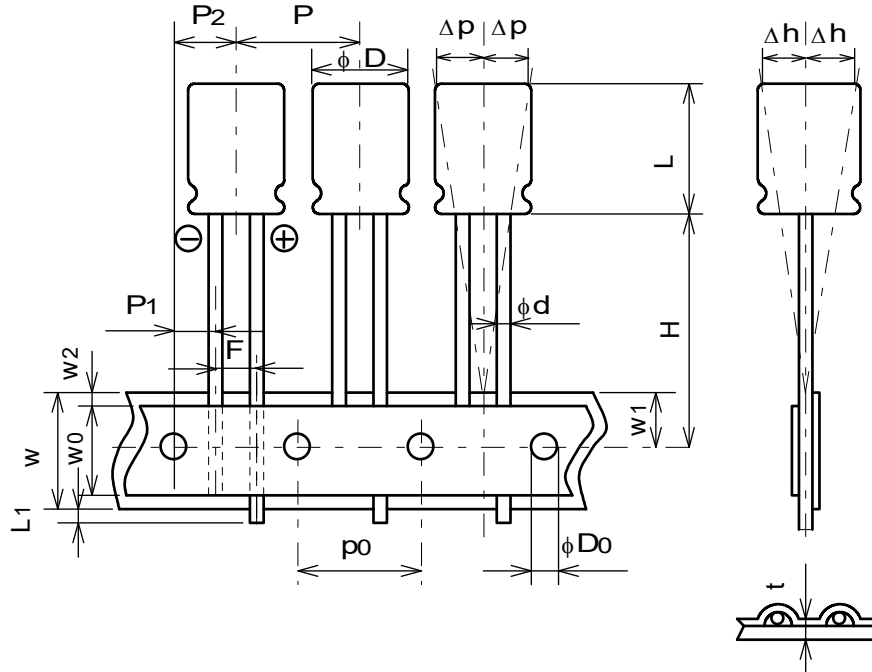

Fig.4

STANDARD PACKING QUANTITY

CAPACITOR SIZE	QUANTITY	WP(mm)
$\phi 8 \times 11.5\text{L}$	1000	54

CODE : T7 (Positive leading)

LEAD TYPE (DIA. $\phi 8$)

Symbol	Case Dia ϕ mm	Remarks
	$\phi 8$	
ϕd	0.6 ± 0.05	Dia. of lead
P	12.7 ± 1.0	Distance from center to center of next body
P_0	12.7 ± 0.2	Distance from center to center of next driving hole
P1	4.6 ± 0.5	Distance between center of driving hole and lead (at the upper edge of the carrier tape)
P2	6.35 ± 1.0	Distance between center of driving hole and body
F	3.5 $\begin{smallmatrix} +0.8 \\ -0.2 \end{smallmatrix}$	Pitch of lead (at the upper edge of the carrier tape)
W	18 ± 0.3	Width of mounting tape
W_0	5 MIN	Width of adhesive tape
W_1	9 ± 0.5	Distance between center of driving hole and mounting tape edge
W_2	1.5 MAX	Max. allowable distance between mounting and adhesive tape edges
H	20 ± 0.75	Distance between center of driving hole and bottom of body
L1	0.5 MAX	End of lead
ϕD_0	4 ± 0.2	Dia. of driving hole
Δh	2 MAX	Off alignment of body top
Δp	1 MAX	Off alignment of body top
t	0.6 ± 0.3	Sum of thickness for mounting and adhesive tape without lead dia.

X-ON Electronics

Largest Supplier of Electrical and Electronic Components

Click to view similar products for [Aluminium Electrolytic Capacitors - Radial Leaded](#) category:

Click to view products by [Rubycon](#) manufacturer:

Other Similar products are found below :

[LXY50VB4.7M-5X11](#) [RFO-100V471MJ7P#](#) [ECE-A1EGE220](#) [B41041A2687M8](#) [B41041A7226M8](#) [B41044A7157M6](#)
[EKXG201EC3101ML20S](#) [EKZM160ETD471MHB5D](#) [NCD681K10KVY5PF](#) [NEV1000M25EF-BULK](#) [NEV100M35DC](#) [NEV100M63DE](#)
[NEV220M25DD-BULK](#) [NEV.33M100AA](#) [NEV4700M50HB](#) [NEV.47M100AA](#) [NEVH1.0M250AB](#) [NEVH3.3M250BB](#) [NEVH3.3M450CC](#)
[KM4700/16](#) [KME50VB100M-8X11.5](#) [SG220M1CSA-0407](#) [ES5107M016AE1DA](#) [ESMG160ETD102MJ16S](#) [ESX472M16B](#) [227RZS050M](#)
[476CKH100MSA](#) [477RZS050M](#) [UVX1V101KPA1FA](#) [UVX1V222MHA1CA](#) [KME25VB100M-6.3X11](#) [VTL100S10](#) [VTL470S10](#)
[VTL470S16A](#) [511D336M250EK5D](#) [052687X](#) [ECE-A1CF471](#) [EKMA500ELL4R7ME07D](#) [NRE-S560M16V6.3X7TBSTF](#) [RGA221M1CTA-](#)
[0611G](#) [ERZA630VHN182UP54N](#) [UPL1A331MPH](#) [SK035M0100AZS-0611](#) [MAL214658821E3](#) [NEV1000M6.3DE](#) [NEV100M16CB](#)
[NEV100M50DD-BULK](#) [NEV2200M16FF](#) [NEV220M50EE](#) [NEV2.2M50AA](#)