

GR2AA THRU GR2MA Fast Recovery Rectifier

Features

- High efficiency
- High current capability
- High reliability
- High surge current capability
- Low power loss
- Glass passivated chip junction
- Solder dip 265 °C max. 10 s, per JESD 22-B106

Typical Applications

For use in general purpose rectification of power supplies, inverters, converters, and freewheeling diodes for consumer, and telecommunication.

Mechanical Data

- Package:SMA
- Molding compound meets UL 94 V-0 flammability rating, RoHS-compliant
- Terminals: Tin plated leads, solderable per J-STD-002 and JESD22-B102
- Polarity:Color band denotes cathode end

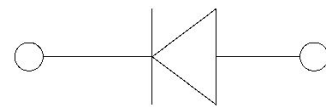
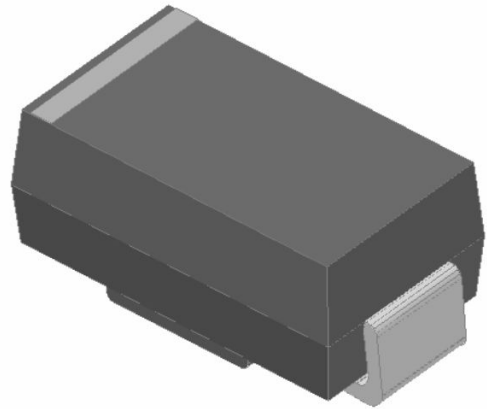

■ Maximum Ratings (Ta=25°C Unless otherwise specified)

PARAMETER	Symbol	Unit	GR2						
			AA	BA	DA	GA	JA	KA	MA
Maximum Repetitive Peak Reverse Voltage	V _{RRM}	V	50	100	200	400	600	800	1000
Maximum RMS Voltage	V _{RMS}	V	35	70	140	280	420	560	700
Maximum DC blocking Voltage	V _{DC}	V	50	100	200	400	600	800	1000
Average Forward Current @Half-sine wave, Resistance load, Tc(Fig.1)	I _o	A	2.0						
Forward Surge Current (Non-repetitive) @60HZ sine wave, 1 cycle, Ta=25°C	I _{FSM}	A	50						
Current squared time @1ms≤t8.3≤ms Ta=25°C, Rating of per diode	I ² t	A ² s	10.4						
Thermal Resistance(Typical) @Between junction and ambient	R _{θJ-A}	°C/W	55						
Storage Temperature	T _{stg}	°C	-55 ~ +150						
Junction Temperature	T _j	°C	-55 ~ +150						

■ Electrical Characteristics (Ta=25°C Unless otherwise specified)

PARAMETER	Symbol	Unit	Conditions	GR2						
				AA	BA	DA	GA	JA	KA	MA
Peak Forward Voltage	V _{FM}	V	I _F =2.0A	1.3						
Peak Reverse Current	I _{RRM}	μA	VR =V _{DC} @Ta=25°C	5						
			VR =V _{DC} @Ta=125°C	200						
Maximum reverse recovery time	T _{rr}	ns	I _F =0.5A,I _R =1.0A, I _{rr} =0.25A	150			250		500	



GR2AA THRU GR2MA

■ Characteristics (Typical)

FIG.1: Io-TL Curve

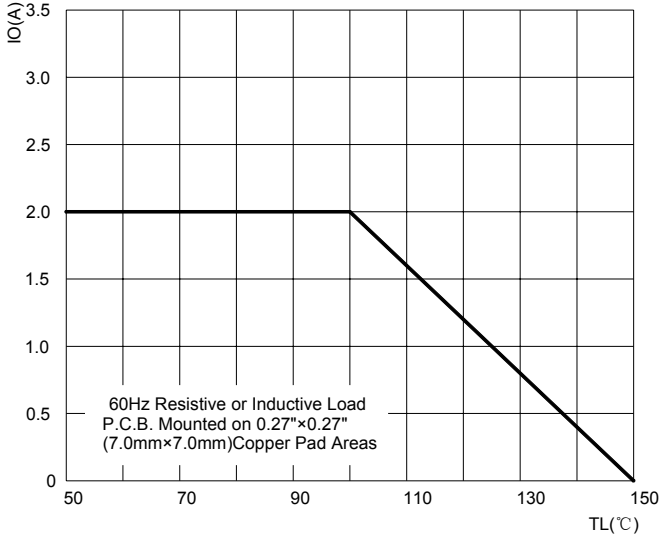

FIG.2: Forward Surge Current Capability

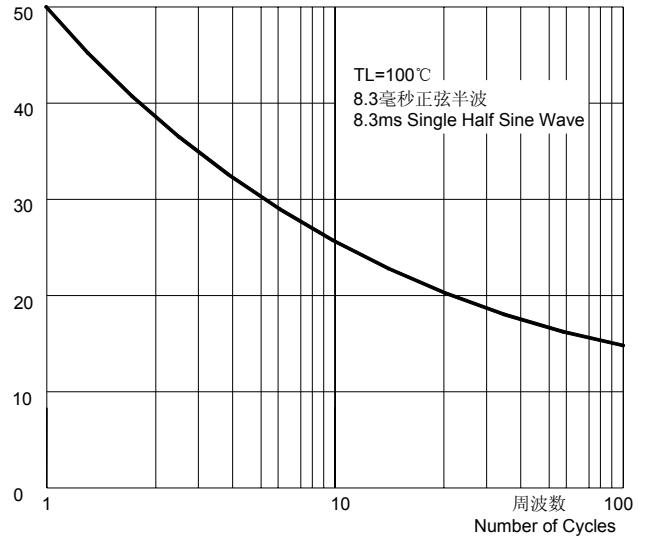

FIG.3: Forward Voltage

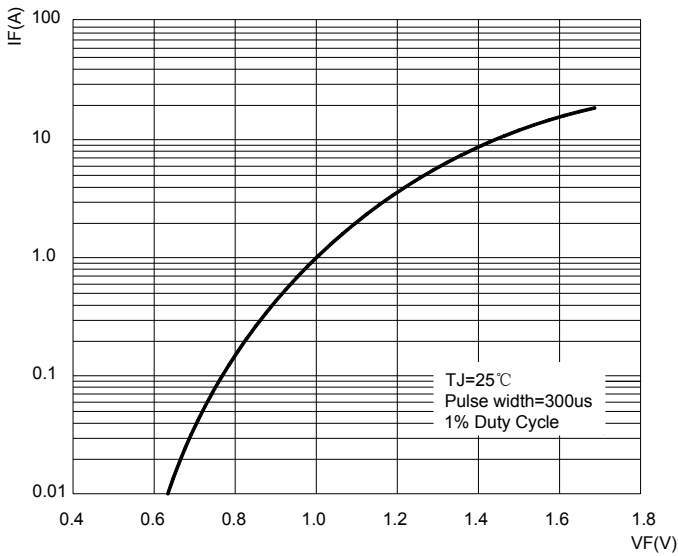

FIG.4: Typical Reverse Characteristics

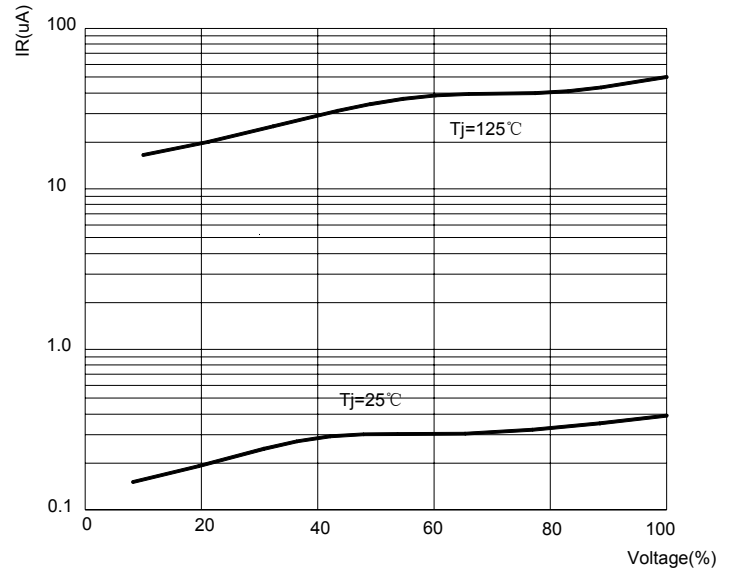
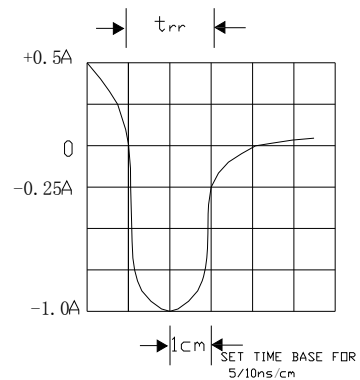
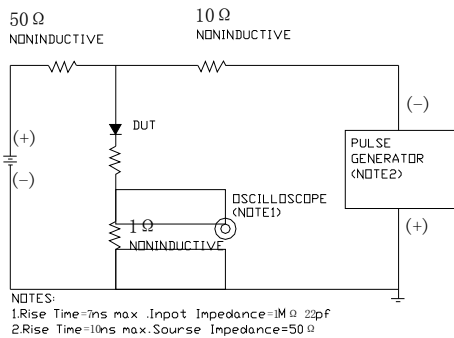

FIG.5: Diagram of circuit and Testing wave form of reverse recovery time



GR2AA THRU GR2MA

Ordering Information (Example)

PREFERED	PACKAGE CODE	MINIMUM PACKAGE(pcs)	INNER BOX QUANTITY(pcs)	OUTER CARTON QUANTITY(pcs)	DELIVERY MODE
GR2AA THRU GR2MA	SMA	5000	10000	80000	13"reel
		7500	15000	120000	13"reel

Outline Dimensions

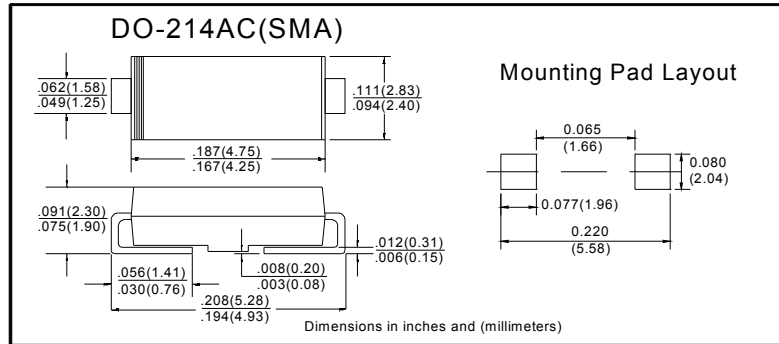

X-ON Electronics

Largest Supplier of Electrical and Electronic Components

Click to view similar products for [Rectifiers](#) category:

Click to view products by [Ruilongyuan](#) manufacturer:

Other Similar products are found below :

[70HFR40](#) [FR105 R0](#) [RL252-TP](#) [1N5397](#) [1N4005-TR](#) [1N4007-BP](#) [UFS120Je3/TR13](#) [20ETS12S](#) [RRE02VS6SGTR](#) [MS306](#) [A1N5404G-G](#)
[CRF02\(T5L,TEMQ\)](#) [ACGRB207-HF](#) [CLH07\(TE16L,Q\)](#) [CLH03\(TE16L,Q\)](#) [1N5395-TP](#) [UES1302](#) [ACGRC307-HF](#) [ACEFC304-HF](#) [DZ-](#)
[1380](#) [85HFR60](#) [40HFR60](#) [70HF120](#) [85HFR80](#) [SCF7500](#) [SM100](#) [ACGRA4001-HF](#) [SKN70/08](#) [NTE5819](#) [NTE5827](#) [NTE5828](#) [NTE5911](#)
[NTE5915](#) [NTE6104](#) [NTE6163](#) [NTE6164](#) [NTE6165](#) [NTE6364](#) [TSD3G](#) [SET130312](#) [NRVUS110VT3G](#) [UES1106](#) [UES1306](#)
[NRVUS240VT3G](#) [D5FE60-5063](#) [R4000GPS-TP](#) [D4015L56TP](#) [UES1306HR2](#) [FX20K120](#) [D20XB60-7101](#)