

MUR2010CT THRU MUR2060CT

Ultra-Fast Recovery Rectifier Diodes

Features

- Super-fast recovery time for high efficiency
- Glass passivated chip junction
- Low leakage current
- High forward surge capability

Typical Application

For use in high frequency rectification and freewheeling application in switching mode converters and inverters for consumer ,computer and telecommunication.

Mechanical Data

- Package: TO-220AB
Molding compound meets UL 94 V-0 flammability rating,RoHS-compliant
- Terminals: Tin plated leads, solderable per J-STD-002 and JESD22-B102
- Polarity: Color Band denotes cathode end

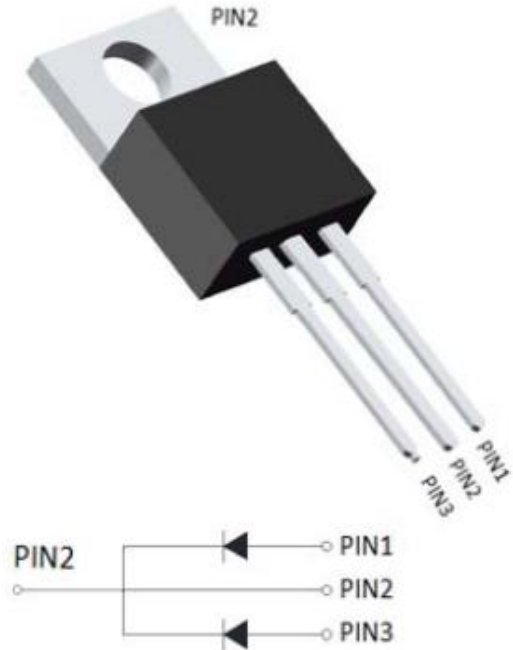

Maximum Ratings (Ta=25°C Unless otherwise specified)

PARAMETER	Symbol	Unit	Conditions	MUR-CT				
				2010	2015	2020	2040	2060
Repetitive Peak Reverse Voltage	VRRM	V		100	150	200	400	600
Average Forward Current	IO	A	60Hz sine wave,R-load	With heatsink Tc =90°C	20			
				Without heatsink Tc =25°C	5			
Surge(Nonrepetitive)Forward Current	IFSM	A	60HZ sine wave, 1 cycle, Ta=25°C	125				
Current Squared Time	I ² t	A ² s	1ms≤t<8.3ms Tj=25°C,Rating of per diode	65				
Storage Temperature	Tstg	°C		-55 ~ +150				
Junction Temperature	Tj	°C		-55 ~ +150				

Electrical Characteristics (Ta=25°C Unless otherwise specified)

PARAMETER	Symbol	Unit	Conditions	MUR-CT				
				2010	2015	2020	2040	2060
Peak Forward Voltage	V _{FM}	V	IFM=10A	0.975			1.3	1.7
Peak Reverse Current	IRRM1	μA	VRM=VRRM	Ta=25°C				
	IRRM2			Ta=125°C				
Maximum reverse recovery time	T _{rr}	ns	I _F =0.5A,I _R =1.0A,I _{rr} =0.25A	25			50	
Thermal Resistance	R _{θJ-C}	R _{θJ-C}	Between junction and case	2.0				



MUR2010CT THRU MUR2060CT

■ Characteristics (Typical)

FIG1: Forward Current Derating Curve

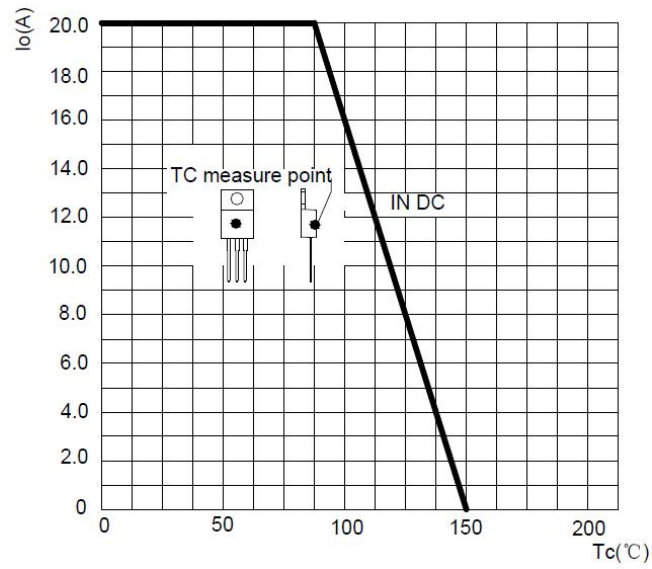

FIG2: Surge Forward Current Capability

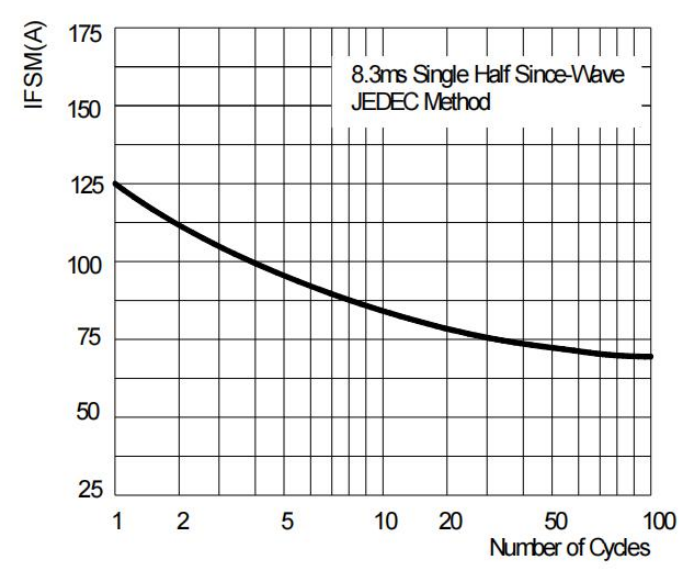

FIG3: Instantaneous Forward Voltage

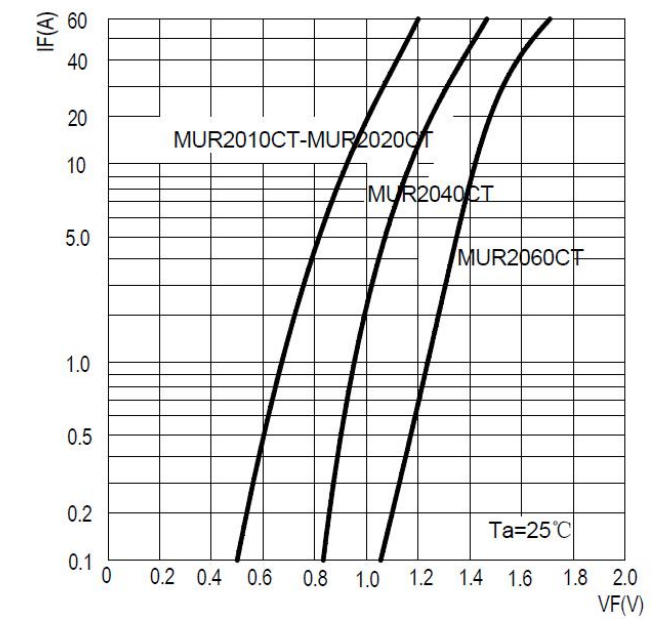

FIG4: Typical Reverse Characteristics

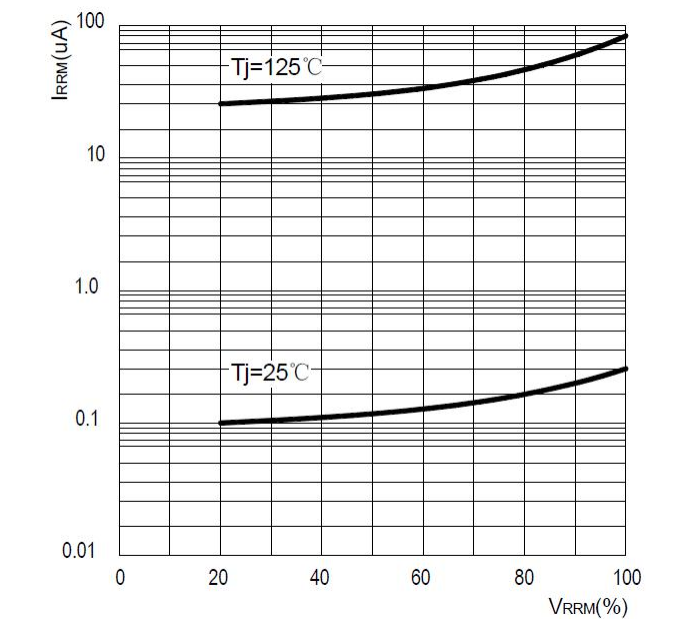
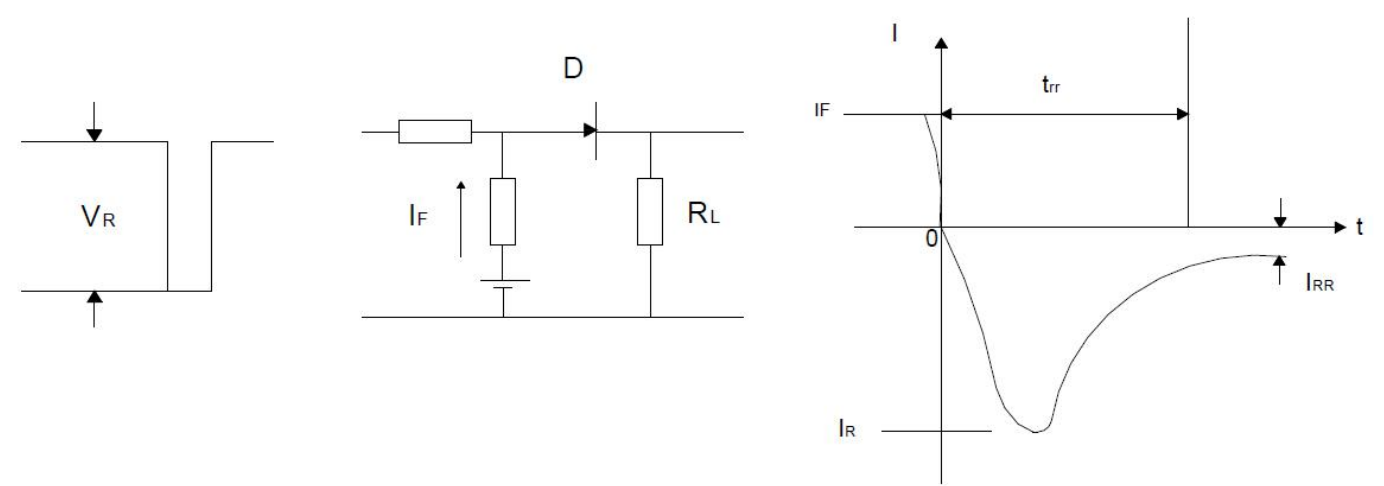

FIG5: Diagram of circuit and Testing wave form of reverse recovery time



MUR2010CT THRU MUR2060CT

Ordering Information (Example)

PREFERED	PACKAGE CODE	MINIMUM PACKAGE(pcs)	INNER BOX QUANTITY(pcs)	OUTER CARTON QUANTITY(pcs)	DELIVERY MODE
MUR1010CT~MUR1060CT	TO-220AB	50	1000	5000	Tube

Outline Dimensions

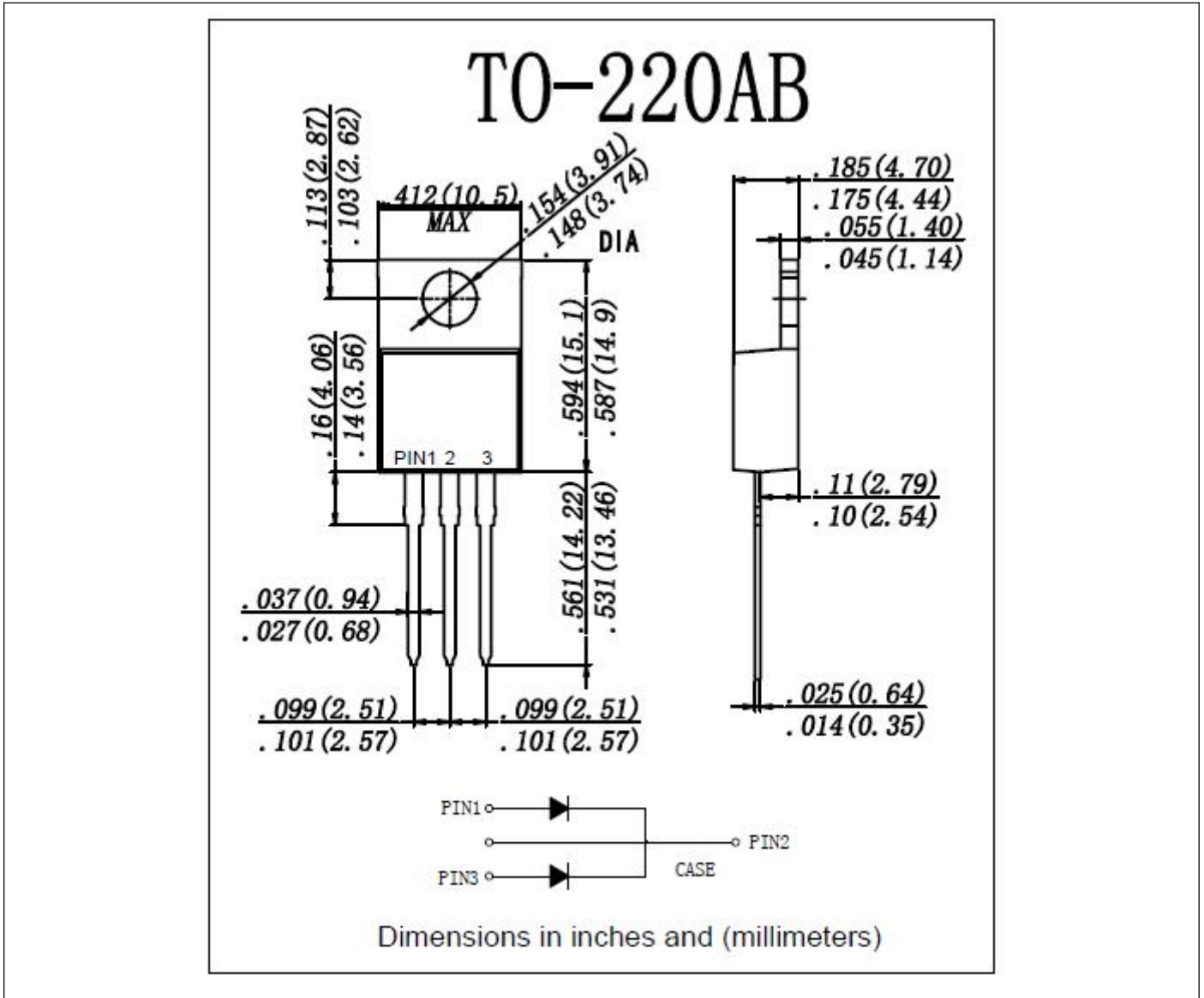

X-ON Electronics

Largest Supplier of Electrical and Electronic Components

Click to view similar products for [Rectifiers](#) category:

Click to view products by [Ruilongyuan](#) manufacturer:

Other Similar products are found below :

[70HFR40](#) [FR105 R0](#) [RL252-TP](#) [1N5397](#) [1N4005-TR](#) [1N4007-BP](#) [UFS120Je3/TR13](#) [20ETS12S](#) [RRE02VS6SGTR](#) [MS306](#) [A1N5404G-G](#)
[CRF02\(T5L,TEMQ\)](#) [ACGRB207-HF](#) [CLH07\(TE16L,Q\)](#) [CLH03\(TE16L,Q\)](#) [1N5395-TP](#) [UES1302](#) [ACGRC307-HF](#) [ACEFC304-HF](#) [DZ-](#)
[1380](#) [85HFR60](#) [40HFR60](#) [70HF120](#) [85HFR80](#) [SCF7500](#) [SM100](#) [ACGRA4001-HF](#) [SKN70/08](#) [NTE5819](#) [NTE5827](#) [NTE5828](#) [NTE5911](#)
[NTE5915](#) [NTE6104](#) [NTE6163](#) [NTE6164](#) [NTE6165](#) [NTE6364](#) [TSD3G](#) [SET130312](#) [NRVUS110VT3G](#) [UES1106](#) [UES1306](#)
[NRVUS240VT3G](#) [D5FE60-5063](#) [R4000GPS-TP](#) [D4015L56TP](#) [UES1306HR2](#) [FX20K120](#) [D20XB60-7101](#)