

Transient Voltage Suppressors - P4KE Series

Features

1. Halogen-free
2. Rohs compliant
3. Typical maximum temperature coefficient
4. $\Delta V_{BR} = 0.1\% \times V_{BR} @ 25^{\circ}\text{C} \times \Delta T$
5. Glass passivated Chip junction in P600 package
6. 400W peak pulse capadility at 10x1000 μs waveform, repetition rate (duty cycles):0.01%
7. Fast response time: typically less than 1.0ps from 0 Volts to BV min
8. Excellent clamping capability
9. Low incremental surge resistance
10. Typical IR less than 5 μA above 11V
11. High temperature soldering guaranteed: 260 $^{\circ}\text{C}/40$ seconds / 0.375", (9.5mm) lead length, 5lbs., (2.3kg)tension
12. Plastic package has underwriters laboratory flammability classification 94v-0
13. Matte Tin Lead-free plated

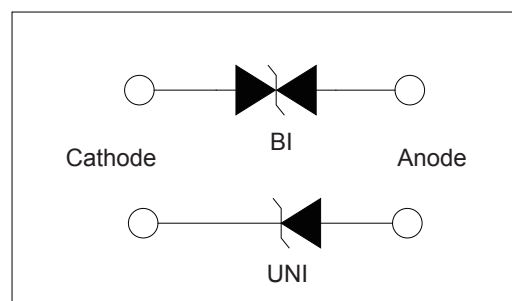
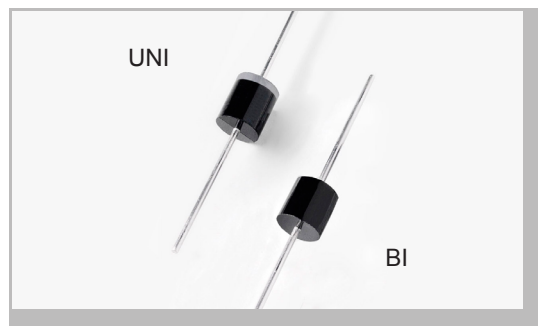

Applications

TVS devices are ideal for the protection of I/O interfaces, VCC bus and other vulnerable circuits used in telecom, computer, industrial and consumer electronic applications.

Mechanical Characteristics

Rating	Symbol	Value	Units
Peak Pulse Power Dissipation by 10x1000 μs test waveform (Fig.1)(Note 1)	P_{PPM}	400	Watts
Steady State Power Dissipation on infinite heat sink at TL=75 $^{\circ}\text{C}$ (Fig. 5)	P_D	1.5	Watts
Peak Forward Surge Current, 8.3ms Single Half Sine Wave Unidirectional only (Note 2)	I_{FSM}	40	Amps
Maximum Instantaneous Forward Voltage at 25A for Unidirectional only (Note 3)	V_F	3.5/5.0	V
Operating junction and Storage Temperature Range.	T_J, T_{STG}	-55 $^{\circ}\text{C}$ to 175 $^{\circ}\text{C}$	$^{\circ}\text{C}$
Typical Thermal Resistance Junction to Lead	$R_{\theta JL}$	6.0	$^{\circ}\text{C}/\text{W}$
Typical Thermal Resistance Junction to Ambient	$R_{\theta JA}$	100	$^{\circ}\text{C}/\text{W}$

Notes:

1. Non-repetitive current pulse , per Fig. 3 and derated above $T_A = 25^{\circ}\text{C}$ per Fig. 2.
2. Measured on 8.3ms single half sine wave or equivalent square wave, duty cycle=4 perminute maximum.
3. $V_F < 3.5\text{V}$ for devices of $V_{BR} < 200\text{V}$ and $V_F < 5.0\text{V}$ for devices of $V_{BR} > 201\text{V}$.

Transient Voltage Suppressors - P4KE Series

Electrical Characteristics

Type Number		Reverse Stand-Off Voltage $V_{RWM}(V)$	Breakdown Voltage@IT		Test Current $I_T(mA)$	Maximum Clamping Voltage@IPP $V_C(V)$	Peak Pulse Current $I_{PP}(A)$	Reverse Leakage @VRWM $I_R(\mu A)$
(UNI)	(BI)		$V_{BR.MIN.}(V)$	$V_{BR.MAX.}(V)$				
P4KE6.8A	P4KE6.8CA	5.80	6.45	7.14	10	10.5	39.0	1000
P4KE7.5A	P4KE7.5CA	6.40	7.13	7.88	10	11.3	36.3	500
P4KE8.2A	P4KE8.2CA	7.02	7.79	8.61	10	12.1	33.9	200
P4KE9.1A	P4KE9.1CA	7.78	8.65	9.55	1	13.4	30.6	50
P4KE10A	P4KE10CA	8.55	9.50	10.50	1	14.5	28.3	10
P4KE11A	P4KE11CA	9.40	10.50	11.60	1	15.6	26.3	5
P4KE12A	P4KE12CA	10.20	11.40	12.60	1	16.7	24.6	5
P4KE13A	P4KE13CA	11.10	12.40	13.70	1	18.2	22.5	5
P4KE15A	P4KE15CA	12.80	14.30	15.80	1	21.2	19.3	5
P4KE16A	P4KE16CA	13.60	15.20	16.80	1	22.5	18.2	5
P4KE18A	P4KE18CA	15.30	17.10	18.90	1	25.5	16.1	5
P4KE20A	P4KE20CA	17.10	19.00	21.00	1	27.7	14.8	5
P4KE22A	P4KE22CA	18.80	20.90	23.10	1	30.6	13.4	5
P4KE24A	P4KE24CA	20.50	22.80	25.20	1	33.2	12.3	5
P4KE27A	P4KE27CA	23.10	25.70	28.40	1	37.5	10.9	5
P4KE30A	P4KE30CA	25.60	28.50	31.50	1	41.4	9.7	5
P4KE33A	P4KE33CA	28.20	31.40	34.70	1	45.7	9.0	5
P4KE36A	P4KE36CA	30.80	34.20	37.80	1	49.9	8.2	5
P4KE39A	P4KE39CA	33.30	37.10	41.00	1	53.9	7.6	5
P4KE43A	P4KE43CA	36.80	40.90	45.20	1	59.3	6.9	5
P4KE47A	P4KE47CA	40.20	44.70	49.40	1	64.8	6.3	5
P4KE51A	P4KE51CA	43.60	48.50	53.60	1	70.1	5.8	5
P4KE56A	P4KE56CA	47.80	53.20	58.80	1	77.0	5.3	5
P4KE62A	P4KE62CA	53.00	58.90	65.10	1	85.0	4.8	5
P4KE68A	P4KE68CA	58.10	64.60	71.40	1	92.0	4.5	5
P4KE75A	P4KE75CA	64.10	71.30	78.80	1	103.0	4.0	5
P4KE82A	P4KE82CA	70.10	77.90	86.10	1	113.0	3.6	5
P4KE91A	P4KE91CA	77.80	86.50	95.50	1	125.0	3.3	5
P4KE100A	P4KE100CA	85.50	95.00	105.00	1	137.0	3.0	5
P4KE110A	P4KE110CA	94.00	105.00	116.00	1	152.0	2.7	5
P4KE120A	P4KE120CA	102.00	114.00	126.00	1	165.0	2.5	5
P4KE130A	P4KE130CA	111.00	124.00	137.00	1	179.0	2.3	5
P4KE150A	P4KE150CA	128.00	143.00	158.00	1	207.0	2.0	5
P4KE160A	P4KE160CA	136.00	152.00	168.00	1	219.0	1.9	5
P4KE170A	P4KE170CA	145.00	162.00	179.00	1	234.0	1.8	5
P4KE180A	P4KE180CA	154.00	171.00	189.00	1	246.0	1.7	5
P4KE200A	P4KE200CA	171.00	190.00	210.00	1	274.0	1.5	5
P4KE220A	P4KE220CA	185.00	209.00	231.00	1	328.0	1.3	5
P4KE250A	P4KE250CA	214.00	237.00	263.00	1	344.0	1.2	5
P4KE300A	P4KE300CA	256.00	285.00	315.00	1	414.0	1.0	5
P4KE350A	P4KE350CA	300.00	332.00	368.00	1	482.0	0.85	5
P4KE400A	P4KE400CA	342.00	380.00	420.00	1	548.0	0.75	5
P4KE440A	P4KE440CA	376.00	418.00	462.00	1	602.0	0.68	5
P4KE480A	P4KE480CA	408.00	456.00	504.00	1	658.0	0.61	5

Transient Voltage Suppressors - P4KE Series

Ratings and Characteristic Curves

Figure 1 - Peak Pulse Power Rating Curve

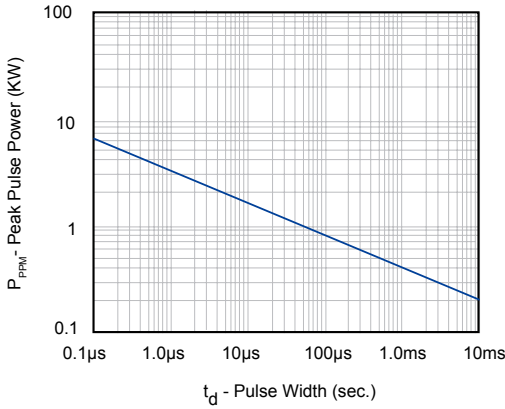

Figure 2 - Pulse Derating Curve

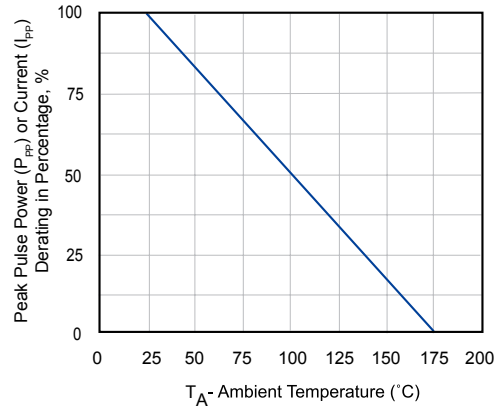

Figure 3 - Pulse Waveform

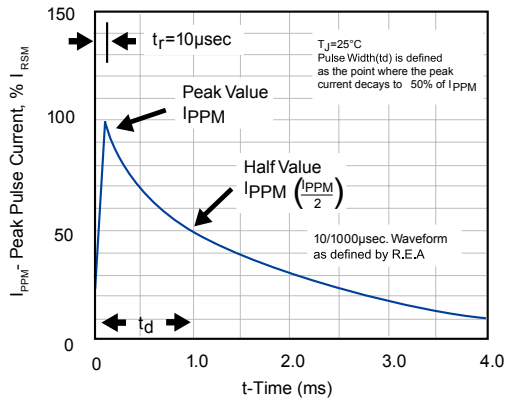

Figure 4 - Typical Junction Capacitance

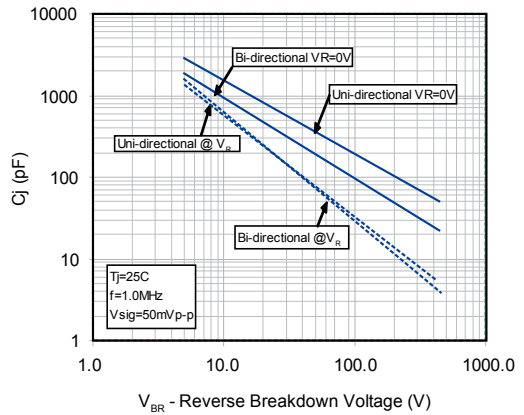

Figure 5 - Steady State Power Derating Curve

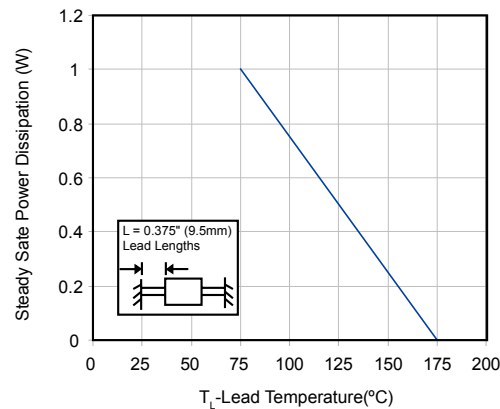
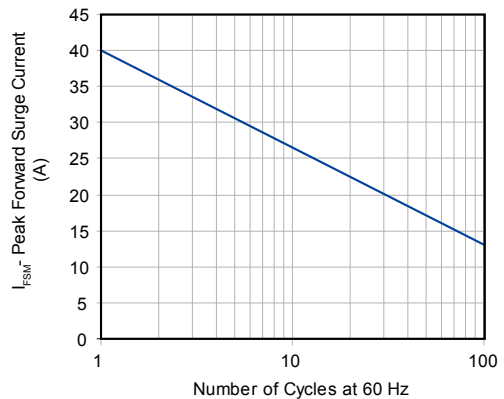

Figure 6 - Maximum Non-Repetitive Peak Forward Surge Current



Transient Voltage Suppressors - P4KE Series

Soldering Parameters

	Flow Condition	Lead-free assembly
Pre Heat	- Temperature Min ($T_{s(min)}$)	150°C
	- Temperature Max ($T_{s(max)}$)	200°C
	- Time (min to max) (t_s)	60-180 secs
Average ramp up rate (Liquidus Temp (T_L) to peak)		3°C/second max
$T_{s(max)}$ to T_L - Ramp-up Rate		3°C/second max
Reflow	- Temperature (T_L) (Liquidus)	217°C
	- Time (min to max) (t_s)	60-150 seconds
Peak Temperature (T_p)		260 ^{+0/-5} °C
Time within 5°C of actual peak Temperature (t_p)		20-40 seconds
Ramp-down Rate		6°C/second max
Time 25°C to peak Temperature (T_p)		8 minutes Max.
Do not exceed		280°C

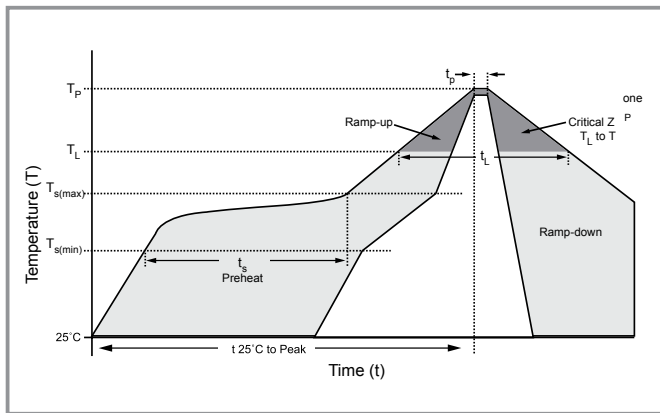

Physical Specifications

Weight	0.045oz., 1.2g
Case	JEDEC DO-201 molded plastic body over passivated junction.
Polarity	Color band denotes the cathode except Bipolar.
Termina	Matte Tin axial leads, solderable per JESD22-B102D.

Environmental Specifications

Temperature Cycle	JESD22-A104
Pressure Cooker	JESD 22-A102
High Temp. Storage	JESD22-A103
HTRB	JESD22-A108
Thermal Shock	JESD22-A106

Flow/Wave Soldering

Peak Temperature :	265°C
Dipping Time :	10 seconds
Soldering :	1 time

Transient Voltage Suppressors - P4KE Series

Dimensions

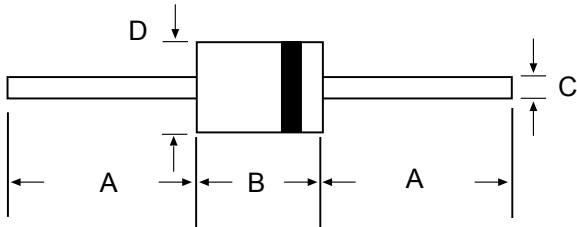

DO-204AL (DO-41)

Unit:mm

DIM	Inches		Millimeters	
	Min	Max	Min	Max
A	1.000	-	25.40	-
B	0.160	0.205	4.10	5.20
C	0.028	0.034	0.71	0.86
D	0.080	0.107	2.00	2.70

Part Numbering System

P4KE xxxXX X

- OPTION CODE:
BLANK Reel Tape
-B Bulk Packaging
- TYPE CODE:
A Uni-Directional (5% Voltage Tolerance)
CA Bi-Directional
- VOLTAGE CODE
(Refer to the Electrical Characteristics table)
- SERIES CODE

Packaging

Part Number	Component Package	Quantity	Packaging Option	Packaging Specification
P4KExxxXX	DO-41	3000	Tape & Reel	ELA STD RS-296E
P4KExxxXX-B	DO-41	1000	BOX	Concord Packing Spec

Warehouse Storage Conditions of Products

- Storage Conditions:
 1. Storage Temperature: -10°C~+40°C
 2. Relative Humidity: ≤75%RH
 3. Keep away from corrosive atmosphere and sunlight.
- Period of Storage: 1 year

X-ON Electronics

Largest Supplier of Electrical and Electronic Components

Click to view similar products for [ESD Suppressors / TVS Diodes](#) category:

Click to view products by [Ruilongyuan](#) manufacturer:

Other Similar products are found below :

[60KS200C](#) [D18V0L1B2LP-7B](#) [D5V0F4U5P5-7](#) [DESD5V0U1BB-7](#) [NTE4902](#) [P4KE27CA](#) [P6KE11CA](#) [P6KE39CA-TP](#) [P6KE8.2A](#)
[SA110CA](#) [SA60CA](#) [SA64CA](#) [SMBJ12CATR](#) [SMBJ33CATR](#) [SMBJ8.0A](#) [ESD101-B1-02ELS E6327](#) [ESD105-B1-02EL E6327](#) [ESD112-B1-02EL E6327](#) [ESD119B1W01005E6327XTSA1](#) [ESD5V0L1B02VH6327XTSA1](#) [ESD7451N2T5G](#) [19180-510](#) [CPDT-5V0USP-HF](#)
[3.0SMCJ33CA-F](#) [3.0SMCJ36A-F](#) [HSPC16701B02TP](#) [D3V3Q1B2DLP3-7](#) [D55V0M1B2WS-7](#) [DESD5V0U1BL-7B](#) [DRTR5V0U4SL-7](#)
[SCM1293A-04SO](#) [ESD200-B1-CSP0201 E6327](#) [SM12-7](#) [SMF8.0A-TP](#) [SMLJ45CA-TP](#) [CEN955 W/DATA](#) [82350120560](#) [VESD12A1A-](#)
[HD1-GS08](#) [CPDUR5V0R-HF](#) [CPDQC5V0U-HF](#) [CPDQC5V0USP-HF](#) [CPDQC5V0-HF](#) [D1213A-01LP4-7B](#) [D1213A-02WL-7](#)
[MMAD1108/TR13](#) [5KP100A](#) [5KP15A](#) [5KP18A](#) [5KP48A](#) [5KP90A](#)