

**Features**

- I RoHS compliant.
- I Bilateral symmetrical.
- I Less decay at on/off state.
- I Approximately zero leaking current before clamping voltage
- I High capability to withstand repeated lightning strikes.
- I Low electrode capacitance( $\leq 1.0\text{pF}$ ) and high isolation ( $\geq 100\text{M}\Omega$ ).
- I Temperature, humidity and lightness insensitive.
- I Working temperature range: :  $-45^{\circ}\text{C} \sim +85^{\circ}\text{C}$
- I Storing temperature range:  $-45^{\circ}\text{C} \sim +85^{\circ}\text{C}$



**Applications**

- I Power Supplies
- I Motor sparks eliminating
- I Relay switching spark absorbing
- I Data line pulse guarding
- I Telephone/Fax/Modem
- I High frequency signal transmitters/receivers
- I Satellite antenna
- I Radio amplifiers
- I Alarm systems
- I Cathode ray tubes in Monitors/ Television Viewing Systems

**Part Number Code**

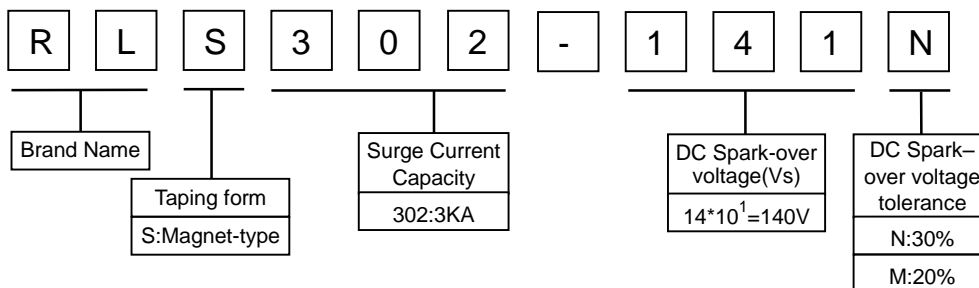

**Electrical Characteristics**

Type Number	DC Spark-Over Voltage	Min. Insulation Resistance		Max. Capacitance (1kHz-6Vmax. )	Surge Current Capacity	Surge Life Test @8/20μs
	Vs	Test Voltage	I <sub>R</sub>	C <sub>j</sub>	8/20μs	
	V	V	MΩ	pF	A	
RLS302-141N	140(126~210)	50	100	1	3000	150A 10 times
RLS302-201M	200±20%	50	100	1	3000	150A 10 times
RLS302-251M	250±20%	100	100	1	3000	150A 10 times
RLS302-301M	300±20%	100	100	1	3000	150A 10 times
RLS302-401M	400±20%	250	100	1	3000	150A 10 times
RLS302-501M	500±20%	250	100	1	3000	150A 10 times
RLS302-601M	600±20%	250	100	1	3000	150A 10 times
RLS302-701M	700±20%	250	100	1	3000	150A 10 times
RLS302-102M	1000±20%	500	100	1	3000	150A 10 times
RLS302-122M	1200±20%	500	100	1	3000	150A 10 times
RLS302-302M	3000±20%	500	100	1	3000	150A 10 times
RLS302-362M	3600±20%	500	100	1	3000	150A 10 times

**Test Methods And Results**

Test Item	Test Method	Specification
DC Spark-over Voltage Vs(V)	Add and measure the DC Voltage gradually Maxto get the discharge threshold voltage. The measuring current is 1mA/1 second max.	It depends on each spec.
Insulation Resistance	Measure the insulation resistance of two end of leadwire under the specified DC voltage.	100MΩ min.
Capacitance Cj(pF)	Measure the Electrostatic Capacitance under the test condition of 1KHz,DC 6V(max).	1pF max.
Life(JSE)	Apply a standard impulse voltage (8X20μsec)of 150A for 5 times with intervals of 30 sec., and then change the polarity of the surge and apply a impulse again. Then measure DC spark-over voltage, IR & Capacitance.	DC spark-over voltage JSE:   Δ Vs/Vs   ≤30%
Life(JSE)	Apply 10 KV voltage charged in 1500pF condenser and apply the current to the specimen,200 times at 10 seconds of intervals	Insulation Resistance & Capacitance to meet the specified value. Appearance: No cracks or failures.
Cold Resistance	Measurement after -40℃ /1000 HRS & normal temperature/2 HRS.	Features are conformed to rated spec.
Heat Resistance	Measurement after 125℃ /1000 HRS & normal temperature/2 HRS.	
Humidity Resistance	Measurement after humidity 90~95 ℃ (45 ℃ )/1000 HRS & normal temperature/2 HRS.	
Temperature Cycle	10 times repetition of cycle -40 ℃ /30min →normal, temp/2 min →125℃ /30min, measurement after normal temp/2 HRS.	
Pull Strength	Apply 0.5kg load for 10sec.	Lead shall not pull out to snap.
Flexural Strength	Bend lead wire at the point of 2mm from body under 0.25 load and back to its original point. Repeat 1 time.	



**Recommended Soldering Conditions**

**Flow Soldering Conditions**

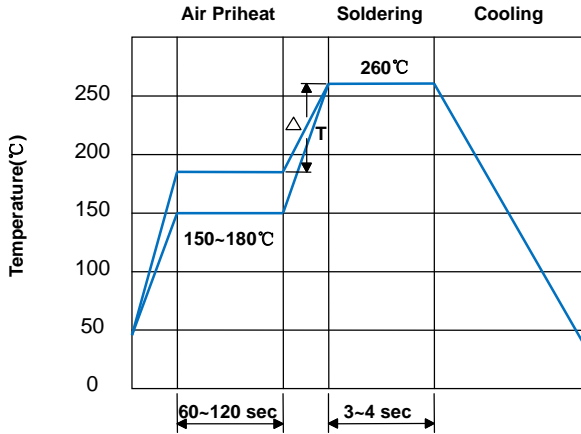

**Hand Soldering**

Solder iron temperature:  $350 \pm 5^\circ\text{C}$   
Heating time: 3 seconds max.

**General attention to soldering**

1. High soldering temperatures and long soldering times can cause leaching of the termination, decrease in adherence strength, and the change of characteristic may occur.
2. For soldering, please refer to the soldering curves above. However, please keep exposures to temperatures exceeding  $200^\circ\text{C}$  to fewer than 50 seconds.
3. Please use a mild flux (containing less than 0.2wt% Cl). Also, if the flux is water soluble, be sure to wash thoroughly to remove any residue from the underside of components that could affect resistance.

- 1) Time shown in the above figures is measured from the point when chip surface reaches temperature.
- 2) Temperature difference in high temperature part should be within  $110^\circ\text{C}$
- 3) After soldering, do not force cool, allow the parts to cool gradually.

**Cleaning**

When using ultrasonic cleaning, the board may resonate if the output power is too high. Since this vibration can cause cracking or a decrease in the adherence of the termination, we recommend that you use the conditions below.

Frequency: 40kHz max.  
Output power: 20W/liter  
Cleaning time: 5 minutes max.

**Dimensions**

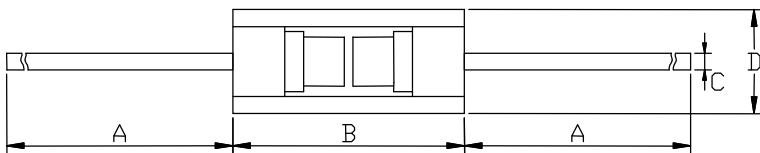

DIM	Millimeters	Inches
A	$28 \pm 2.0$	$1.102 \pm 0.079$
B	$6.7 \pm 1.0$	$0.264 \pm 0.039$
C	$0.5 \pm 0.05$	$0.02 \pm 0.002$
D	$\Phi 3.1 \pm 0.5$	$\Phi 0.122 \pm 0.02$



Packaging Information

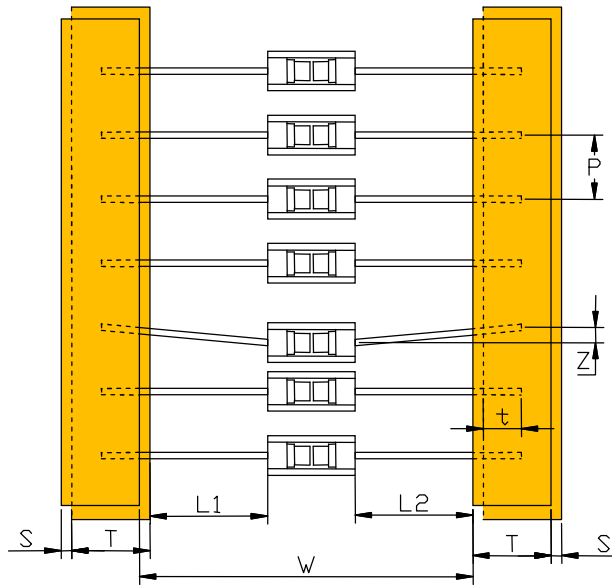

Symbol	Millimeters	Inches
<b>W</b>	52.5±1.5	2.067±0.059
<b>P</b>	5.0±0.5	0.197±0.02
<b>L1-L2</b>	1.0 max	0.039max
<b>T</b>	6.0±1.0	0.236±0.039
<b>Z</b>	1.2max	0.047max
<b>t</b>	3.2max	0.126max
<b>S</b>	0.8max	0.031max
<b>A</b>	75.0	2.953
<b>B</b>	68.0	2.677
<b>C</b>	255.0	10.039
<b>Quantity: 1500PCS/ inner box</b>		

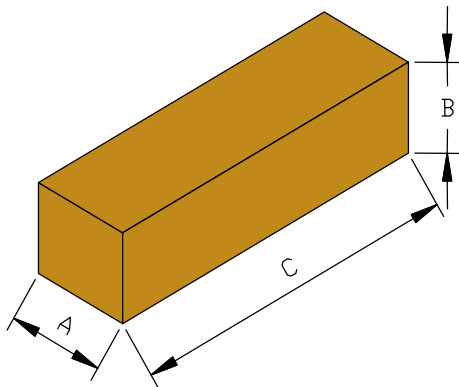

## X-ON Electronics

Largest Supplier of Electrical and Electronic Components

*Click to view similar products for* [Gas Discharge Tubes - GDTs / Gas Plasma Arrestors](#) *category:*

*Click to view products by* [Ruilongyuan](#) *manufacturer:*

Other Similar products are found below :

[PMT1023004](#) [PMT1025001](#) [RF3161-000](#) [PMT1035004](#) [PMT1040004](#) [PMT809006](#) [CG2250](#) [CG2800](#) [CG31.5L](#) [GT-SMD181240012-TR](#)  
[WPGT-2N145B6L](#) [WPGT-2N230B6L](#) [WPGT-2N470B6L](#) [WPGT-2R470B6L](#) [WPGT-2RM230A6L](#) [WPGT-2RM350A6L](#) [WPGT-](#)  
[2RM70A6L](#) [WPGT-2RM90A6L](#) [WPGT-2S145](#) [WPGT-2S350](#) [WPGT-2S470](#) [WPGT-3R350CF](#) [WPGT-3R350G1](#) [WPGT-3R90G1](#) [WPGT-](#)  
[3R75G1](#) [WPGT-3R470G1](#) [WPGT-3R250C](#) [WPGT-3R230G1](#) [WPGT-2S230](#) [WPGT-2RM470A6L](#) [WPGT-2RM145A6L](#) [WPGT-2R3000B8L](#)  
[WPGT-2R2700B8L](#) [WPGT-2R1000B8L](#) [WPGT-2N90B6L](#) [WPGT-2N70B6L](#) [WPGT-2N350B6L](#) [WPGT-2N230B6L1](#) [CG90](#) [CG2230](#)  
[CG2145](#) [CG21000](#) [GT-SMD181215012-TR](#) [9071.99.0547 \(73\\_Z-0-0-547\)](#) [B88069X6940B152](#) [V20-1+NPE-280](#) [V20-3+NPE+FS-280](#)  
[SD09-V24 9](#) [C50-0-255](#) [SG24PA300](#)