

## Description

RLST236A054LV are surge rated diode arrays designed to protect high speed data interfaces. The LV series has been specifically designed to protect sensitive components which are connected to data and transmission lines from overvoltage caused by electrostatic discharge (ESD), electrical fast transients (EFT), and lightning.

The unique design of the LV series devices incorporates eight surge rated, low capacitance steering diodes and a TVS diode in a single package. During transient conditions, the steering diodes direct the transient to either the positive side of the power supply line or to ground. The internal TVS diode prevents over-voltage on the power line, protecting any downstream components.

The RLST236A054LV has a low typical capacitance of 3pF and operates with virtually no insertion loss to 1GHz. This makes the device ideal for protection of high-speed data lines such as USB 2.0, Firewire, DVI, and gigabit Ethernet interfaces. The low capacitance array configuration allows the user to protect four high-speed data or transmission lines. The low inductance construction minimizes voltage overshoot during high current surges. They may be used to meet the ESD immunity requirements of IEC 61000-4-2, Level 4 ( $\pm 15\text{kV}$  air,  $\pm 8\text{kV}$  contact discharge).

## Features

- Stand-off Voltage: 5v
- Peak Power up to 300W@8\*20 $\mu$ s Pulse
- Low Leakage current IEC61000-4-2
- Level 4 ESD Protection IEC61000-4-4
- Level 4 EFT Protection
- Low capacitance: 0.7pF typical

## Mechanical Characteristics

- SOT-23 6L package
- Molding compound flammability rating: UL 94V-0
- Packaging : Tape and Reel per EIA 481
- pb-Free Packages are Available

## Applications

- USB 2.0 Power and Data Line Protection
- Video Graphics Cards
- Monitors and Flat Panel Displays
- Digital Video Interface (DVI)
- 10/100/1000 Ethernet
- Notebook Computers
- SIM Ports
- ATM Interfaces
- IEEE 1394 Firewire Ports

## Circuit Diagram

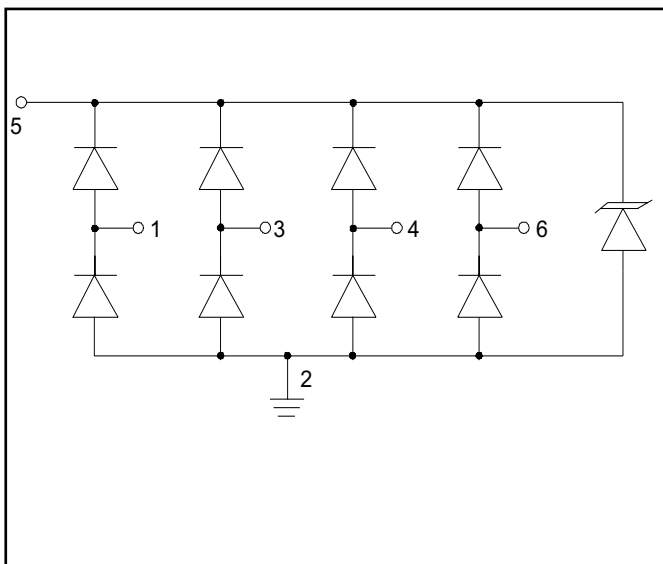

## Pin Configuration

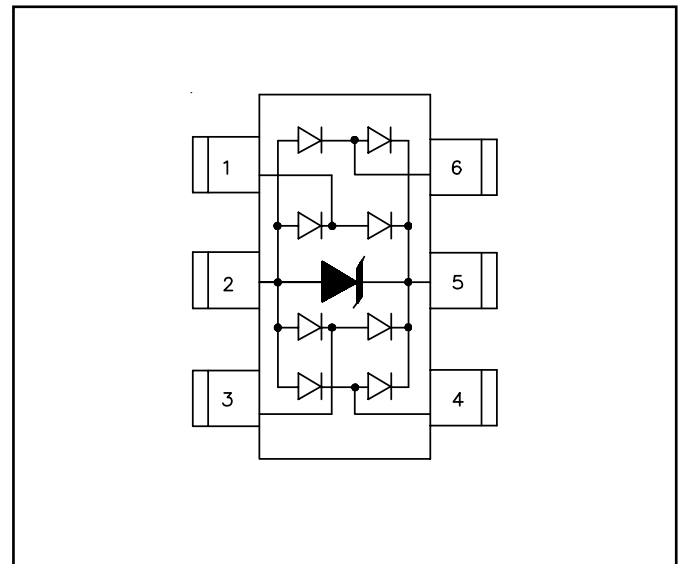

## Protection Products

### Absolute Maximum Rating

Rating	Symbol	Value	Units
Peak Pulse Power ( $t_p = 8/20\mu s$ )	$P_{PK}$	300	Watts
ESD per IEC 61000-4-2 (Air) ESD per IEC 61000-4-2 (Contact)	$V_{ESD}$	15 8	kV
Lead Soldering Temperature	$T_K$	260 (10 sec.)	°C
Operating Temperature	$T_J$	-55 to +125	°C
Storage Temperature	$T_{STG}$	-55 to +150	°C

### Electrical Characteristics (T=25°C)

#### RLST236A054LV

Parameter	Symbol	Conditions	Minimum	Typical	Maximum	Units
Reverse Stand-Off Voltage	$V_{RWM}$	-	-	-	5	V
Reverse Breakdown Voltage	$V_{BR}$	$I_t = 1mA$	6	7	-	V
Reverse Leakage Current	$I_R$	$V_{RWM} = 5V, T = 25^\circ C$ Pin 5 to 2	-	-	5	$\mu A$
Clamping Voltage	$V_C$	$I_{PP} = 1A, t_p = 8/20\mu s$ Any I/O pin to Ground	-	-	12	V
Junction Capacitance	$C_j$	$V_R = 0V, f = 1MHz$ Any I/O pin to Ground	-	1.2	1.5	pF
		$V_R = 0V, f = 1MHz$ Between I/O pins	-	0.7	-	pF

Non-Repetitive Peak Pulse Power vs. Pulse Time

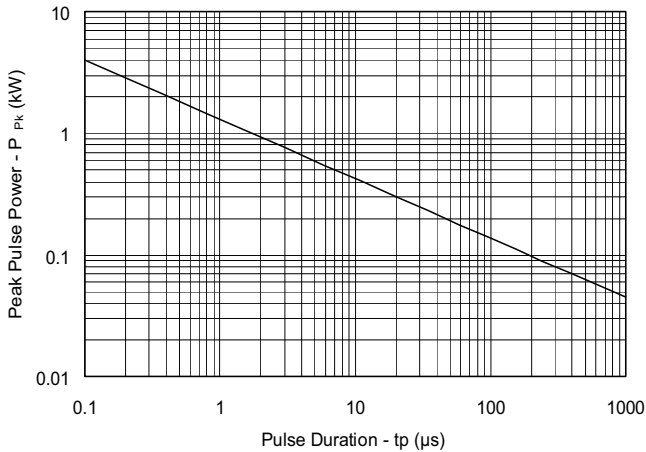

Power Derating Curve

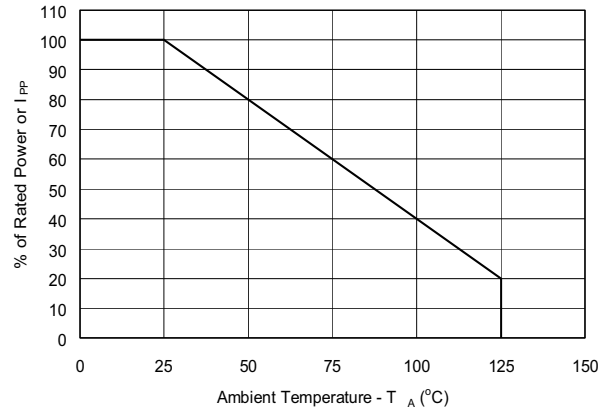

Pulse Waveform

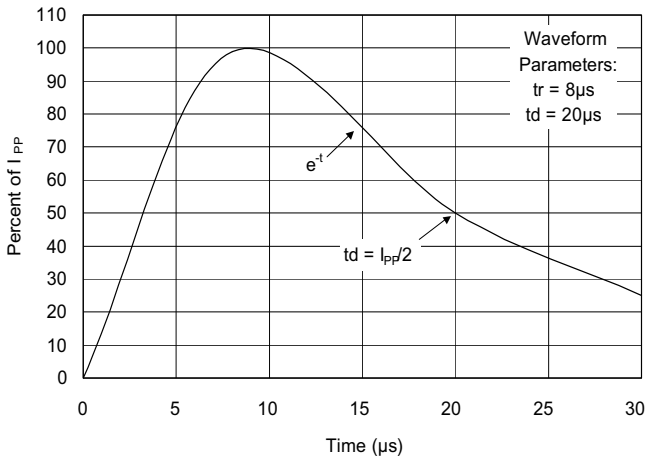

Clamping Voltage vs. Peak Pulse Current

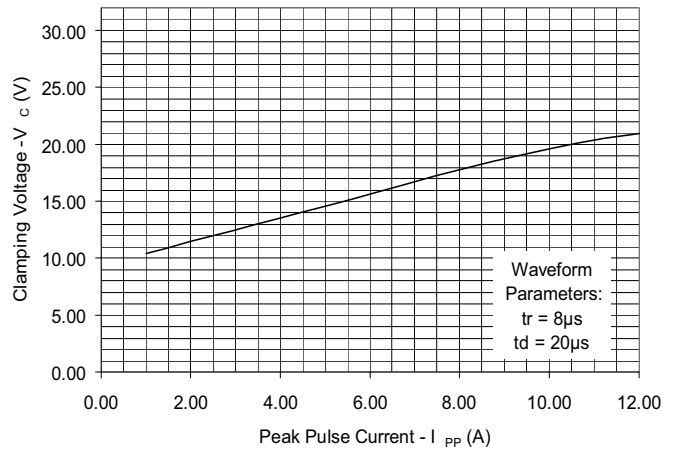

Forward Voltage vs. Forward Current

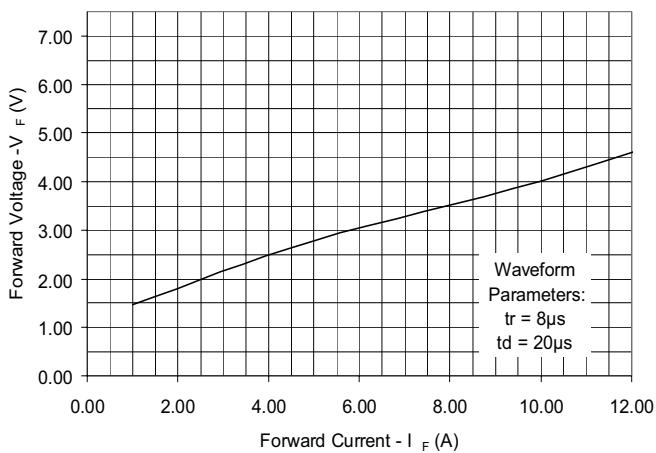

Normalized Capacitance vs. Reverse Voltage

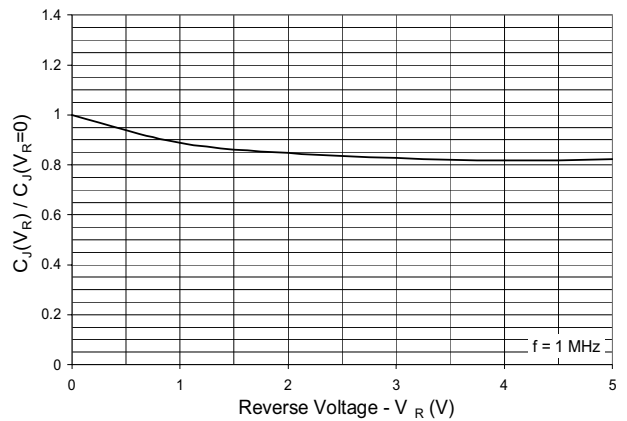

Insertion Loss S21

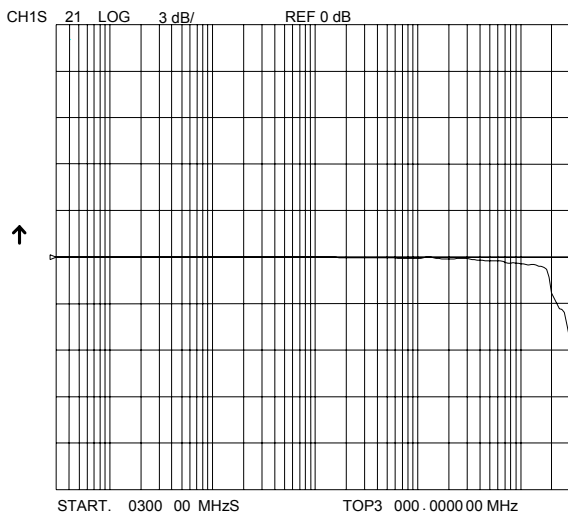

Analog Cross Talk

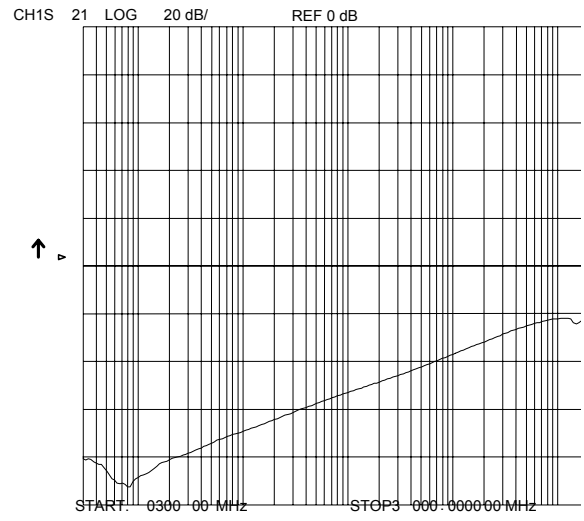

### Device Connection Options for Protection of Four High-Speed Data Lines

The RLST236A054LV TVS is designed to protect four data lines from transient over-voltages by clamping them to a fixed reference. When the voltage on the protected line exceeds the reference voltage (plus diode  $V_F$ ) the steering diodes are forward biased, conducting the transient current away from the sensitive circuitry. Data lines are connected at pins 1, 3, 4 and 6. The negative reference (REF1) is connected at pin 2. This pin should be connected directly to a ground plane on the board for best results. The path length is kept as short as possible to minimize parasitic inductance. The positive reference (REF2) is connected at pin 5. The options for connecting the positive reference are as follows:

1. To protect data lines and the power line, connect pin 5 directly to the positive supply rail ( $V_{CC}$ ). In this configuration the data lines are referenced to the supply voltage. The internal TVS diode prevents over-voltage on the supply rail.
2. The RLST236A054LV can be isolated from the power supply by adding a series resistor between pin 5 and  $V_{CC}$ . A value of  $100k\Omega$  is recommended. The internal TVS and steering diodes remain biased, providing the advantage of lower capacitance.
3. In applications where no positive supply reference is available, or complete supply isolation is desired, the internal TVS may be used as the reference. In this case, pin 5 is not connected. The steering diodes will begin to conduct when the voltage on the protected line exceeds the working voltage of the TVS (plus one diode drop). ESD Protection With RLST236A054LV. RLST236A054LV are optimized for ESD protection using the rail-to-rail topology. Along with good board layout, these devices virtually eliminate the disadvantages of using discrete components to implement this topology. Consider the situation shown in Figure 1 where discrete diodes or diode arrays are configured for rail-to-rail protection on a high speed line. During positive duration ESD events, the top diode will be forward biased when the voltage on the protected line exceeds

### Data Line and Power Supply Protection Using $V_{CC}$ as reference

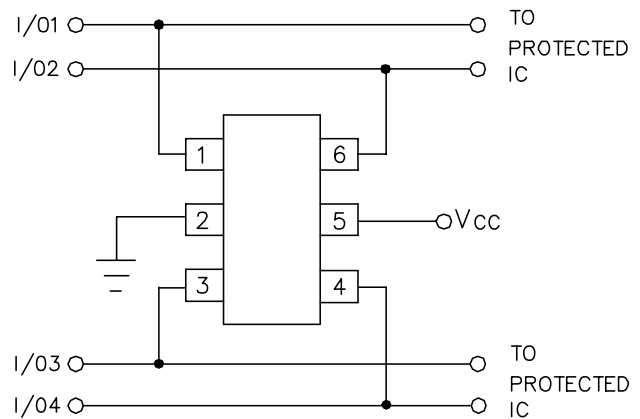

### Data Line Protection with Bias and Power Supply Isolation Resistor

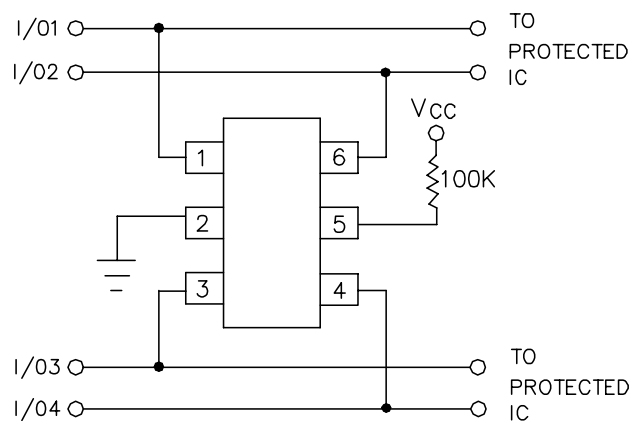

### Data Line Protection Using Internal TVS Diode as Reference

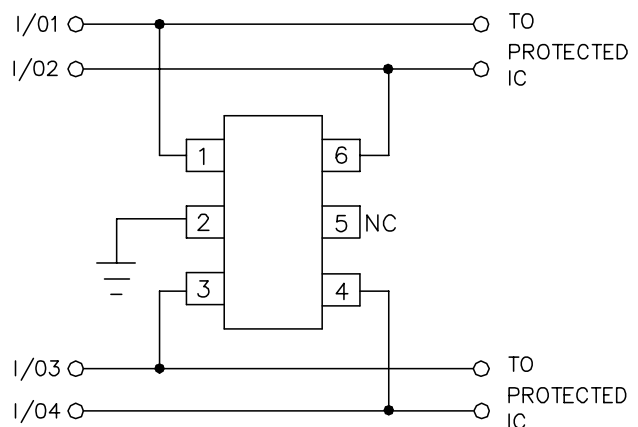

## Protection Products

### Applications Information

the reference voltage plus the  $V_F$  drop of the diode. For negative events, the bottom diode will be biased when the voltage exceeds the  $V_F$  of the diode. At first approximation, the clamping voltage due to the characteristics of the protection diodes is given by:  
 $V_C = V_{CC} + V_F$  (for positive duration pulses)  
 $V_C = -V_F$  (for negative duration pulses)

However, for fast rise time transient events, the effects of parasitic inductance must also be considered as shown in Figure 2. Therefore, the actual clamping voltage seen by the protected circuit will be:

$V_C = V_{CC} + V_F + L_P di_{ESD}/dt$  (for positive duration pulses)  
 $V_C = -V_F - L_G di_{ESD}/dt$  (for negative duration pulses)

ESD current reaches a peak amplitude of 30A in 1ns for a level 4 ESD contact discharge per IEC 61000-4-2. Therefore, the voltage overshoot due to 1nH of series inductance is:

$V = L_P di_{ESD}/dt = 1 \times 10^{-9} (30 / 1 \times 10^{-9}) = 30V$

Example:

Consider a  $V_{CC} = 5V$ , a typical  $V_F$  of 30V (at 30A) for the steering diode and a series trace inductance of 10nH.

The clamping voltage seen by the protected IC for a positive 8kV (30A) ESD pulse will be:

$V_C = 5V + 30V + (10nH \times 30V/nH) = 335V$

This does not take into account that the ESD current is directed into the supply rail, potentially damaging any components that are attached to that rail. Also note that it is not uncommon for the  $V_F$  of discrete diodes to exceed the damage threshold of the protected IC. This is due to the relatively small junction area of typical discrete components. It is also possible that the power dissipation capability of the discrete diode will be exceeded, thus destroying the device. The RLST236A054LV is designed to overcome the inherent disadvantages of using discrete signal diodes for ESD suppression. The RLST236A054LV integrated TVS diode

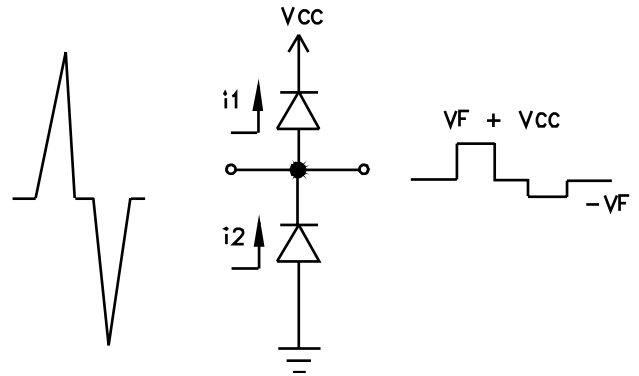

Figure 1 - “Rail-To-Rail” Protection Topology (First Approximation)

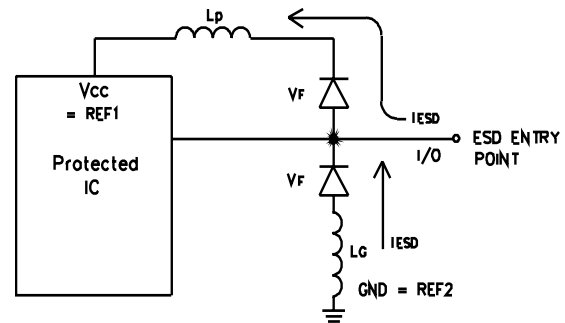

Figure 2 - The Effects of Parasitic Inductance When Using Discrete Components to Implement Rail-To-Rail Protection

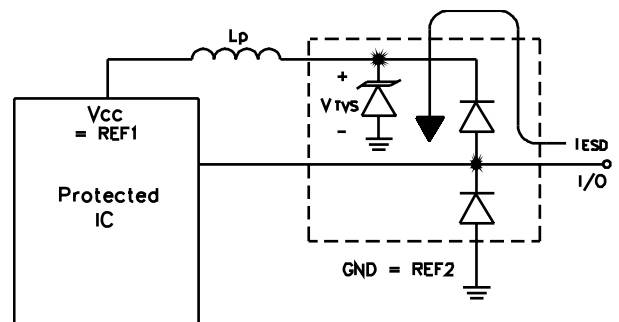

Figure 3 - Rail-To-Rail Protection Using RailClamp TVS Arrays

helps to mitigate the effects of parasitic inductance in the power supply connection. During an ESD event, the current will be directed through the integrated TVS diode to ground. The maximum voltage seen by the protected IC due to this path will be the clamping voltage of the device.

### Video Interface Protection

Video interfaces are susceptible to transient voltages resulting from electrostatic discharge (ESD) and “hot plugging” cables. If left unprotected, the video interface IC may be damaged or even destroyed. Protecting a high-speed video port presents some unique challenges. First, any added protection device must have extremely low capacitance and low leakage current so that the integrity of the video signal is not compromised. Second, the protection component must be able to absorb high voltage transients without damage or degradation. As a minimum, the device should be rated to handle ESD voltages per IEC 61000-4-2, level 4 ( $\pm 15\text{kV}$  air,  $\pm 8\text{kV}$  contact). The clamping voltage of the device (when conducting high current ESD pulses) must be sufficiently low enough to protect the sensitive CMOS IC. If the clamping voltage is too high, the “protected” device may latch-up or be destroyed. Finally, the device must take up a relatively small amount of board space, particularly in portable applications such as notebooks and handhelds. The RLST236A054LV is designed to meet or exceed all of the above criteria. A typical video interface protection circuit is shown in Figure 4. All exposed lines are protected including R, G, B, H-Sync, V-Sync, and the ID lines for plug and play monitors.

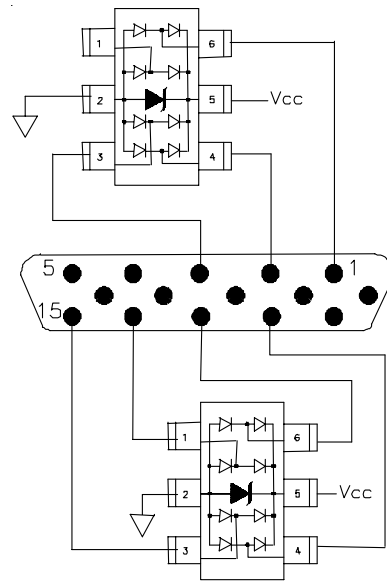

Figure 4 - Video Interface Protection

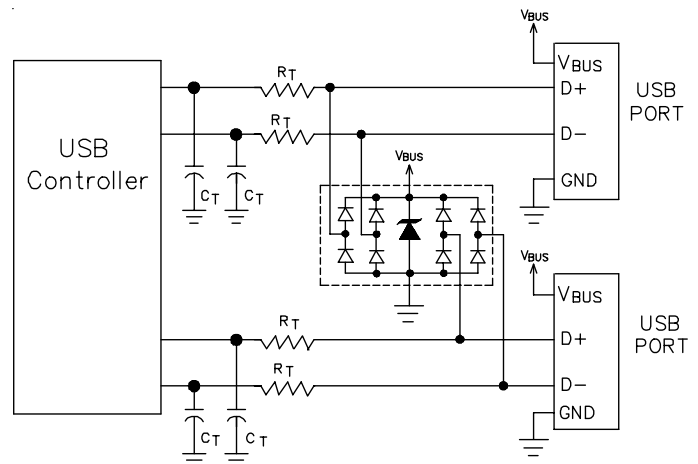

Figure 5 - Dual USB Port Protection

### Universal Serial Bus ESD Protection

The RLST236A054LV may also be used to protect the USB ports on monitors, computers, peripherals or portable systems. Each device will protect up to two USB ports (Figure 5). When the voltage on the data lines exceed the bus voltage (plus one diode drop), the internal rectifiers are forward biased conducting the transient current away from the protected controller chip. The TVS diode directs the surge to ground. The TVS diode also acts to suppress ESD strikes directly on the voltage bus. Thus, both power and data pins are protected with a single device.

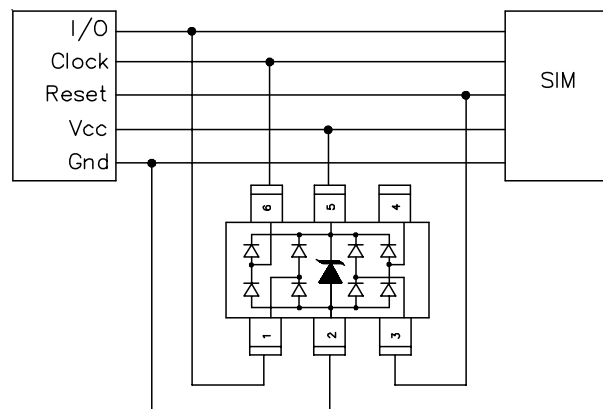

Figure 6 - SIM Port

### DVI Protection

The small geometry of a typical digital-visual interface (DVI) graphic chip will make it more susceptible to electrostatic discharges (ESD) and cable discharge events (CDE). Transient protection of a DVI port can be challenging. Digital-visual interfaces can often transmit and receive at a rate equal to or above 1Gbps. The high-speed data transmission requires the protection device to have low capacitance to maintain signal integrity and low clamping voltage to reduce stress on the protected IC. The RLST236A054LV has a low typical insertion loss of <math><0.4\text{dB}</math> at 1GHz (I/O to ground) to ensure signal integrity and can protect the DVI interface to the 8kV contact and 15kV air ESD per IEC 61000-4-2 and CDE.

Figure 7 shows how to design the RLST236A054LV into the DVI circuit on a flat panel display and a PC graphic card. The RLST236A054LV is configured to provide common mode and differential mode protection. The internal TVS of the RLST236A054LV acts as a 5 volt reference. The power pin of the DVI circuit does not come out through the connector and is not subjected to external ESD pulse; therefore, pin 5 should be left unconnected. Connecting pin 5 to Vcc of the DVI circuit may result in damage to the chip from ESD current.

### 10/100 ETHERNET PROTECTION

Ethernet ICs are vulnerable to damage from electrostatic discharge (ESD). The internal protection in the PHY chip, if any, often is not enough due to the high energy of the discharges specified by IEC 61000-4-2. If the discharge is catastrophic, it will destroy the protected IC. If it is less severe, it will cause latent failures that are very difficult to find.

10/100 Ethernet operates at 125MHz clock over a twisted pair interface. In a typical system, the twisted pair interface for each port consists of two differential signal pairs: one for the transmitter and one for the receiver, with the transmitter input being the most sensitive to damage. The fatal discharge occurs differentially across the transmit or receive line pair and is capacitively coupled through the transformer to the Ethernet chip. Figure 8 shows how to design the RLST236A054LV on the line side of a 10/100 ethernet port to provide differential mode protection. The common mode isolation of the transformer will provide common mode protection to the rating of the transformer isolation which is usually >1.5kV. If more common mode protection is needed, figure 9 shows how to design the RLST236A054LV on the IC side of the 10/100

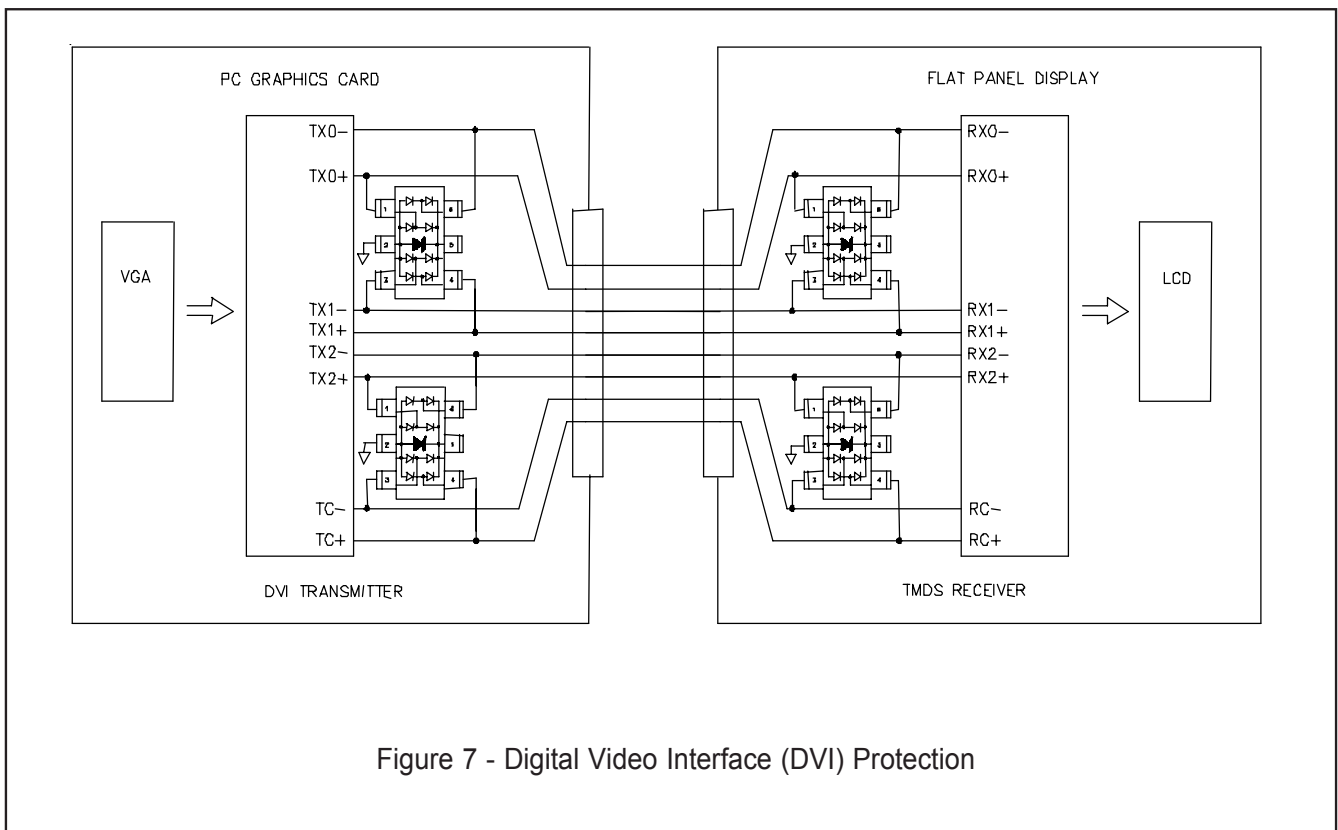



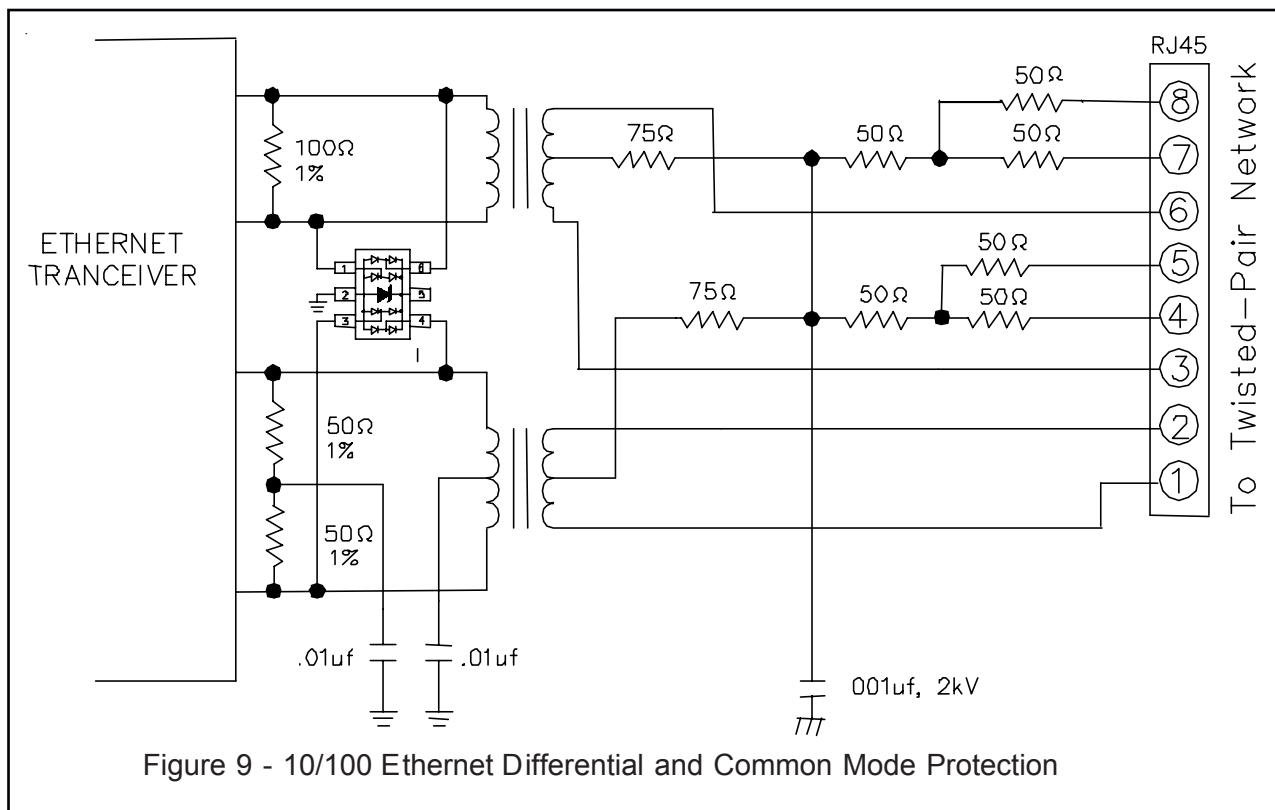
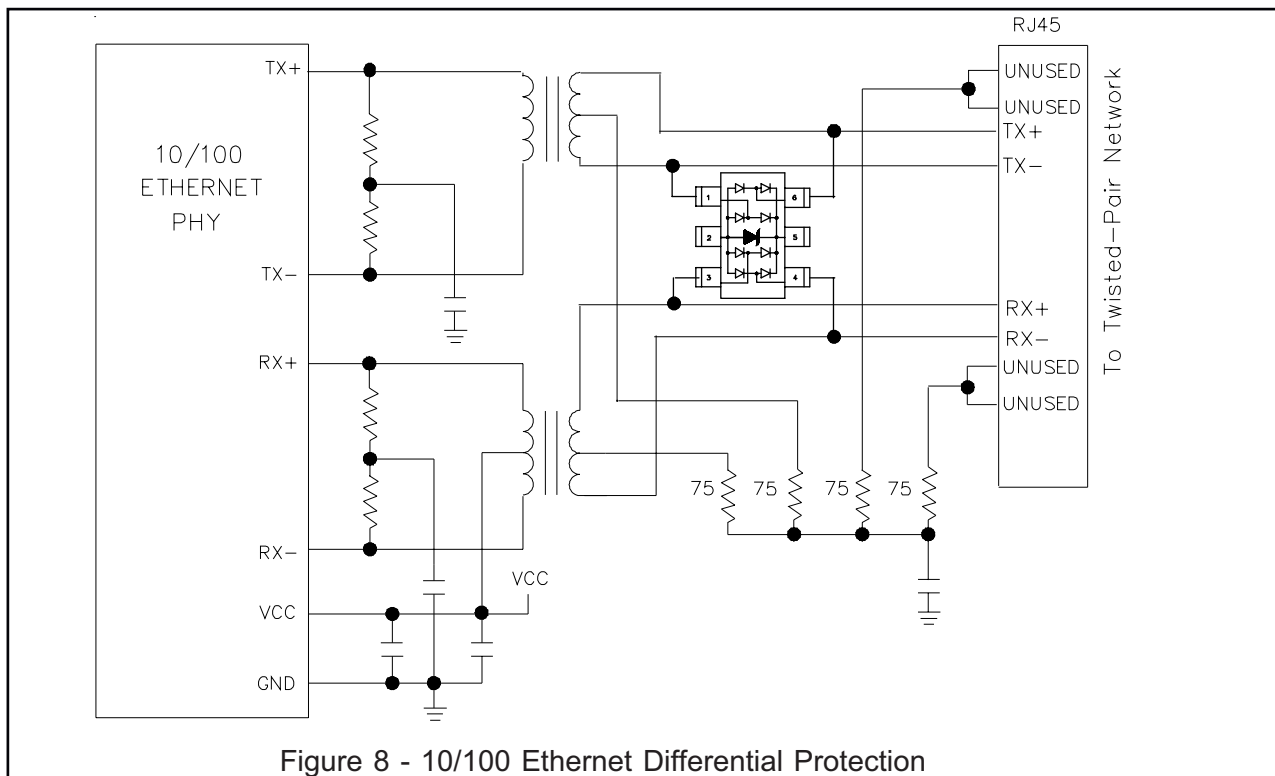

# Protection Products

## Outline Drawing - SOT-23 6L

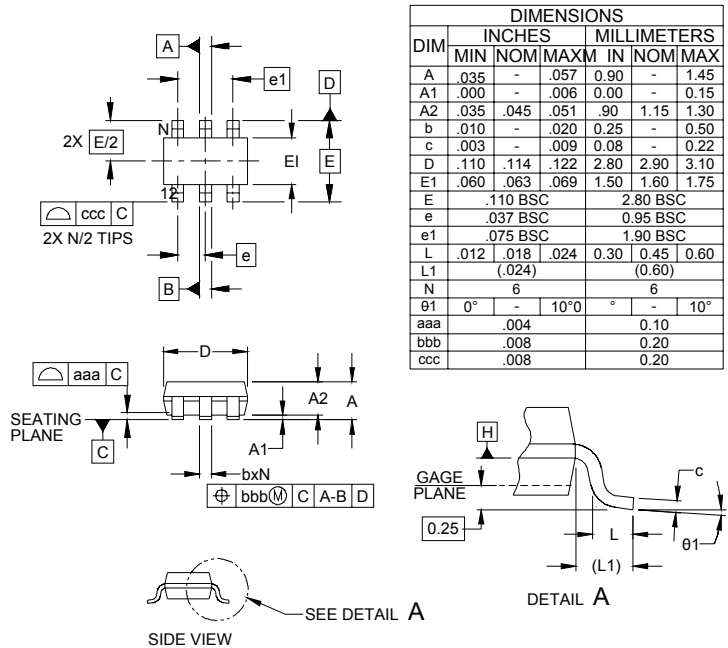

DIM	INCHES			MILLIMETERS		
	MIN	NOM	MAX	IN	NOM	MAX
A	.035	-	.057	0.90	-	1.45
A1	.000	-	.006	0.00	-	0.15
A2	.035	.045	.051	.90	1.15	1.30
b	.010	-	.020	0.25	-	0.50
c	.003	-	.009	0.08	-	0.22
D	.110	.114	.122	2.80	2.90	3.10
E1	.060	.063	.069	1.50	1.60	1.75
E	.110 BSC			2.80 BSC		
e	.037 BSC			0.95 BSC		
e1	.075 BSC			1.90 BSC		
L	.012	.018	.024	0.30	0.45	0.60
L1	(.024)			(0.60)		
N	6			6		
θ1	0°		- 10°	°		- 10°
aaa	.004			0.10		
bbb	.008			0.20		
ccc	.008			0.20		

- NOTES:
1. CONTROLLING DIMENSIONS ARE IN MILLIMETERS (ANGLES IN DEGREES).
  2. DATUMS [A] AND [B] TO BE DETERMINED AT DATUM PLANE [H].
  3. DIMENSIONS "E1" AND "D" DO NOT INCLUDE MOLD FLASH, PROTRUSIONS OR GATE BURRS.

## Land Pattern - SOT-23 6L

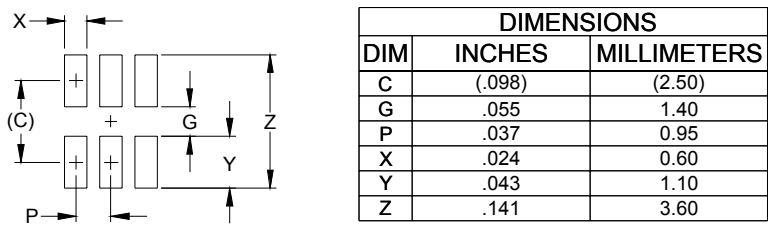

- NOTES:
1. THIS LAND PATTERN IS FOR REFERENCE PURPOSES ONLY. CONSULT YOUR MANUFACTURING GROUP TO ENSURE YOUR COMPANY'S MANUFACTURING GUIDELINES ARE MET.

RUILONG.YUAN CO.,LTD  
Tel: +86- 0755-82908296  
Fax: +86- 0755-82908002

Email: [jack@ruilon.com](mailto:jack@ruilon.com)  
Website: <http://www.ruilon.com>

RuiLongYuan Electronics are trademarks.

Information furnished is believed to be accurate and reliable. However, users should independently evaluate the suitability of and test each product selected for their own applications. RUILONYUAN Electronics reserves the right to change or update, without notice, any information contained in this publication; to change, without notice, the design, construction, processing, or specification of any product; and to discontinue or limit production or distribution of any product. This publication supersedes and replaces all information previously supplied. Without expressed or written consent by an officer of RUILONYUAN Electronics, RUILONYUAN Electronics does not authorize the use of any of its products as components in nuclear facility applications, aerospace, or in critical life support devices or systems. RUILONYUAN Electronics expressly disclaims all implied warranties regarding the information contained herein, including, but not limited to, any implied warranties of merchantability or fitness for a particular purpose. RUILONYUAN Electronics' only obligations are those in the RUILONYUAN Electronics Standard Terms and Conditions of Sale and in no case will RUILONYUAN Electronics be liable for any incidental, indirect, or consequential damages.

## X-ON Electronics

Largest Supplier of Electrical and Electronic Components

*Click to view similar products for [ESD Suppressors / TVS Diodes](#) category:*

*Click to view products by [Ruilongyuan](#) manufacturer:*

Other Similar products are found below :

[60KS200C](#) [D18V0L1B2LP-7B](#) [D5V0F4U5P5-7](#) [DESD5V0U1BB-7](#) [NTE4902](#) [P4KE27CA](#) [P6KE11CA](#) [P6KE39CA-TP](#) [P6KE8.2A](#)  
[SA110CA](#) [SA60CA](#) [SA64CA](#) [SMBJ12CATR](#) [SMBJ33CATR](#) [SMBJ8.0A](#) [ESD101-B1-02ELS E6327](#) [ESD105-B1-02EL E6327](#) [ESD112-B1-02EL E6327](#) [ESD119B1W01005E6327XTSA1](#) [ESD5V0L1B02VH6327XTSA1](#) [ESD7451N2T5G](#) [19180-510](#) [CPDT-5V0USP-HF](#)  
[3.0SMCJ33CA-F](#) [3.0SMCJ36A-F](#) [HSPC16701B02TP](#) [D3V3Q1B2DLP3-7](#) [D55V0M1B2WS-7](#) [DESD5V0U1BL-7B](#) [DRTR5V0U4SL-7](#)  
[SCM1293A-04SO](#) [ESD200-B1-CSP0201 E6327](#) [SM12-7](#) [SMF8.0A-TP](#) [SMLJ45CA-TP](#) [CEN955 W/DATA](#) [82350120560](#) [VESD12A1A-](#)  
[HD1-GS08](#) [CPDUR5V0R-HF](#) [CPDQC5V0U-HF](#) [CPDQC5V0USP-HF](#) [CPDQC5V0-HF](#) [D1213A-01LP4-7B](#) [D1213A-02WL-7](#)  
[MMAD1108/TR13](#) [5KP100A](#) [5KP15A](#) [5KP18A](#) [5KP48A](#) [5KP90A](#)