

Description

The SMAJ series is designed specifically to protect sensitive electronic equipment from voltage transients induced by lightning and other transient voltage events.

Features

- I Fast response time
- I Low incremental surge resistance
- I Matte tin lead-free Plated
- I Halogen free and RoHS compliant
- I Typical IR less than 1μA above 10V
- I Compatible with industrial standard package DO-214AC
- I For surface mounted applications to optimize board space
- I 400W peak pulse power capability with at 10/1000μs waveform, repetition rate (duty cycle): 0.01%
- I High temperature soldering:260°C/10 seconds at terminals

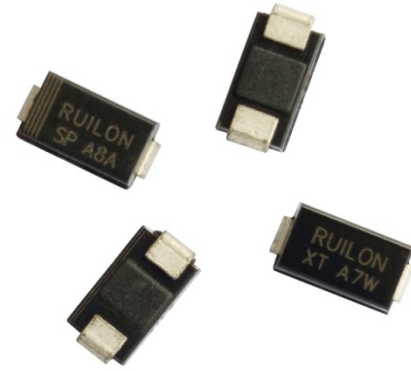

Electrical symbol

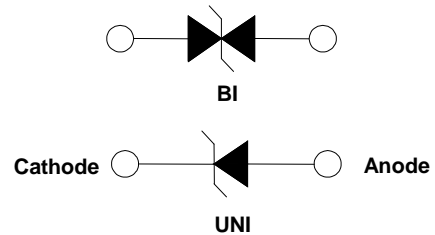

Part Number Code

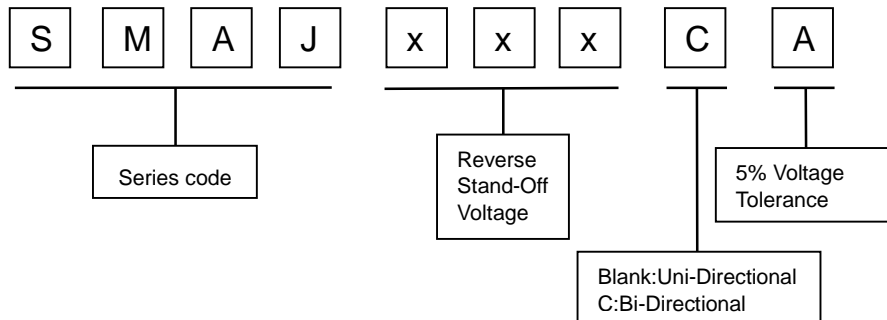

Mechanical Characteristics

Rating	Symbol	Value	Units
Peak Pulse Power Dissipation at $T_A=25^{\circ}C$ by 10/1000μs Waveform (Fig.2)(Note 1), (Note 2)	P_{PP}	400	W
Power Dissipation on Infinite Heat Sink at $T_L=75^{\circ}C$ (Fig.6)	P_D	3.0	W
Peak Forward Surge Current, 8.3ms Single Half Sine Wave (Note 3)	I_{FSM}	40	A
Operating Temperature Range	T_J	-55 to 150	$^{\circ}C$
Storage Temperature Range	T_{STG}	-55 to 150	$^{\circ}C$

- Notes:
1. Non-repetitive current pulse, per Fig.4 and derated above $T_A=25^{\circ}C$ per Fig. 3.
 2. Mounted on 5.0x5.0mm copper pad to each terminal.
 3. Measured on 8.3ms single half sine wave or equivalent square wave for unidirectional device only.



Electrical Characteristics

Type Number		Marking		Reverse Stand-Off Voltage	Breakdown Voltage		Test Current	Max. Clamping Voltage 10/1000µs	Max. Peak Pulse Current 10/1000µs	Reverse Leakage
					V _{RWM}	V _{BR} @I _T				
				UNI		BI	UNI	BI	V	Min
				V	V	V	mA	V	A	µA
SMAJ5.0A	SMAJ5.0CA	HE	TE	5.0	6.40	7.00	10	9.2	43.5	800
SMAJ6.0A	SMAJ6.0CA	HG	TG	6.0	6.67	7.37	10	10.3	38.8	800
SMAJ6.5A	SMAJ6.5CA	HK	TK	6.5	7.22	7.98	10	11.2	35.7	500
SMAJ7.0A	SMAJ7.0CA	HM	TM	7.0	7.78	8.60	10	12.0	33.3	200
SMAJ7.5A	SMAJ7.5CA	HP	TP	7.5	8.33	9.21	1	12.9	31.0	100
SMAJ8.0A	SMAJ8.0CA	HR	TR	8.0	8.89	9.83	1	13.6	29.4	50
SMAJ8.5A	SMAJ8.5CA	HT	TT	8.5	9.44	10.40	1	14.4	27.8	10
SMAJ9.0A	SMAJ9.0CA	HV	TV	9.0	10.00	11.10	1	15.4	26.0	5
SMAJ10A	SMAJ10CA	HX	TX	10.0	11.10	12.30	1	17.0	23.5	5
SMAJ11A	SMAJ11CA	HZ	TZ	11.0	12.20	13.50	1	18.2	22.0	1
SMAJ12A	SMAJ12CA	IE	UE	12.0	13.30	14.70	1	19.9	20.1	1
SMAJ13A	SMAJ13CA	IG	UG	13.0	14.40	15.90	1	21.5	18.6	1
SMAJ14A	SMAJ14CA	IK	UK	14.0	15.60	17.20	1	23.2	17.2	1
SMAJ15A	SMAJ15CA	IM	UM	15.0	16.70	18.50	1	24.4	16.4	1
SMAJ16A	SMAJ16CA	IP	UP	16.0	17.80	19.70	1	26.0	15.4	1
SMAJ17A	SMAJ17CA	IR	UR	17.0	18.90	20.90	1	27.6	14.5	1
SMAJ18A	SMAJ18CA	IT	UT	18.0	20.00	22.10	1	29.2	13.7	1
SMAJ20A	SMAJ20CA	IV	UV	20.0	22.20	24.50	1	32.4	12.3	1
SMAJ22A	SMAJ22CA	IX	UX	22.0	24.40	26.90	1	35.5	11.3	1
SMAJ24A	SMAJ24CA	IZ	UZ	24.0	26.70	29.50	1	38.9	10.3	1
SMAJ26A	SMAJ26CA	JE	VE	26.0	28.90	31.90	1	42.1	9.5	1
SMAJ28A	SMAJ28CA	JG	VG	28.0	31.10	34.40	1	45.4	8.8	1
SMAJ30A	SMAJ30CA	JK	VK	30.0	33.30	36.80	1	48.4	8.3	1
SMAJ33A	SMAJ33CA	JM	VM	33.0	36.70	40.60	1	53.3	7.5	1
SMAJ36A	SMAJ36CA	JP	VP	36.0	40.00	44.20	1	58.1	6.9	1
SMAJ40A	SMAJ40CA	JR	VR	40.0	44.40	49.10	1	64.5	6.2	1
SMAJ43A	SMAJ43CA	JT	VT	43.0	47.80	52.80	1	69.4	5.8	1
SMAJ45A	SMAJ45CA	JV	VV	45.0	50.00	55.30	1	72.7	5.5	1
SMAJ48A	SMAJ48CA	JX	VX	48.0	53.30	58.90	1	77.4	5.2	1
SMAJ51A	SMAJ51CA	JZ	VZ	51.0	56.70	62.70	1	82.4	4.9	1



Electrical Characteristics

Type Number		Marking		Reverse Stand-Off Voltage	Breakdown Voltage		Test Current	Max. Clamping Voltage 10/1000 μ s	Max. Peak Pulse Current 10/1000 μ s	Reverse Leakage
				V_{RWM}	$V_{BR} @ I_T$		I_T	$V_C @ I_{PP}$	I_{PP}	$I_R @ V_{RWM}$
					Min	Max				
UNI	BI	UNI	BI	V	V	V	mA	V	A	μ A
SMAJ54A	SMAJ54CA	RE	WE	54.0	60.00	66.30	1	87.1	4.6	1
SMAJ58A	SMAJ58CA	RG	WG	58.0	64.40	71.20	1	93.6	4.3	1
SMAJ60A	SMAJ60CA	RK	WK	60.0	66.70	73.70	1	96.8	4.1	1
SMAJ64A	SMAJ64CA	RM	WM	64.0	71.10	78.60	1	103.0	3.9	1
SMAJ70A	SMAJ70CA	RP	WP	70.0	77.80	86.00	1	113.0	3.5	1
SMAJ75A	SMAJ75CA	RR	WR	75.0	83.30	92.10	1	121.0	3.3	1
SMAJ78A	SMAJ78CA	RT	WT	78.0	86.70	95.80	1	126.0	3.2	1
SMAJ85A	SMAJ85CA	RV	WV	85.0	94.40	104.00	1	137.0	2.9	1
SMAJ90A	SMAJ90CA	RX	WX	90.0	100.0	111.00	1	146.0	2.7	1
SMAJ100A	SMAJ100CA	RZ	WZ	100.0	111.0	123.00	1	162.0	2.5	1
SMAJ110A	SMAJ110CA	SE	XE	110.0	122.0	135.00	1	177.0	2.3	1
SMAJ120A	SMAJ120CA	SG	XG	120.0	133.0	147.00	1	193.0	2.1	1
SMAJ130A	SMAJ130CA	SK	XK	130.0	144.0	159.00	1	209.0	1.9	1
SMAJ150A	SMAJ150CA	SM	XM	150.0	167.0	185.00	1	243.0	1.6	1
SMAJ160A	SMAJ160CA	SP	XP	160.0	178.0	197.00	1	259.0	1.5	1
SMAJ170A	SMAJ170CA	SR	XR	170.0	189.0	209.00	1	275.0	1.5	1
SMAJ180A	SMAJ180CA	ST	XT	180.0	201.0	222.00	1	292.0	1.4	1
SMAJ190A	SMAJ190CA	SV	XV	190.0	209.0	233.00	1	306.0	1.3	1
SMAJ200A	SMAJ200CA	SX	XX	200.0	224.0	247.00	1	324.0	1.2	1
SMAJ210A	SMAJ210CA	SZ	XZ	210.0	231.0	258.00	1	324.0	1.1	1
SMAJ220A	SMAJ220CA	ZE	YE	220.0	246.0	272.00	1	356.0	1.1	1
SMAJ250A	SMAJ250CA	ZG	YG	250.0	279.0	309.0	1	405.0	1.0	1
SMAJ300A	SMAJ300CA	ZK	YK	300.0	335.0	371.0	1	486.0	0.8	1
SMAJ350A	SMAJ350CA	ZM	YM	350.0	391.0	432.0	1	567.0	0.7	1
SMAJ400A	SMAJ400CA	ZP	YP	400.0	447.0	494.0	1	648.0	0.6	1
SMAJ440A	SMAJ440CA	ZR	YR	440.0	492.0	543.0	1	713.0	0.6	1

Notes: For bidirectional type having V_R of 10V and less, the I_R limit is double.



I-V Curve Characteristics

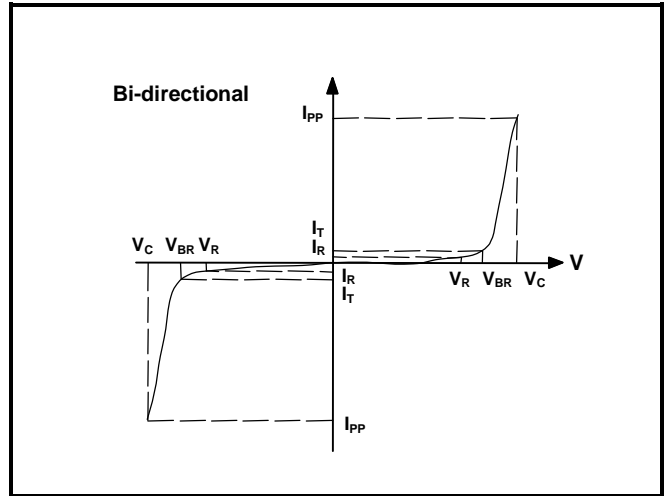
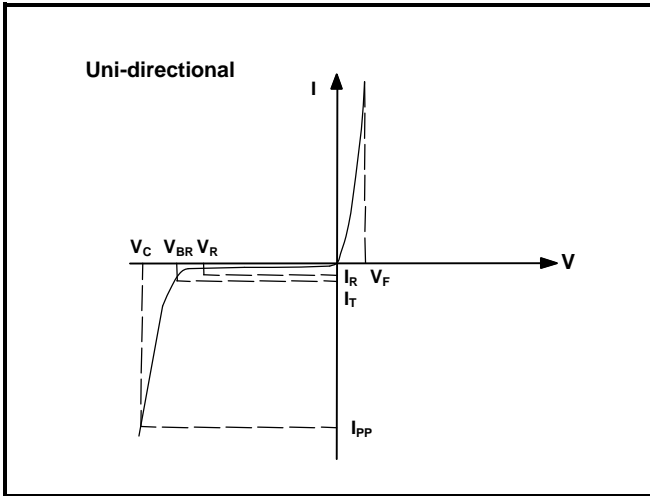

P_{PPM} Peak Pulse Power Dissipation -- Max power dissipation

V_R Stand-off Voltage -- Maximum voltage that can be applied to the TVS without operation

V_{BR} Breakdown Voltage -- Maximum voltage that flows through the TVS at a specified test current (I_T)

V_C Clamping Voltage -- Peak voltage measured across the TVS at a specified I_{ppm} (peak impulse current)

I_R Reverse Leakage Current -- Current measured at V_R

V_F Forward Voltage Drop for Uni-directional

Ratings and Characteristic Curves ($T_A=25^\circ\text{C}$ unless otherwise noted)

Figure 1 - TVS Transients Clamping Waveform

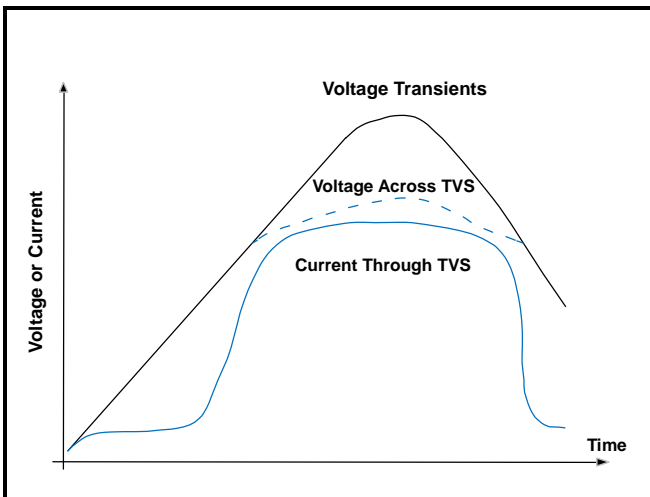
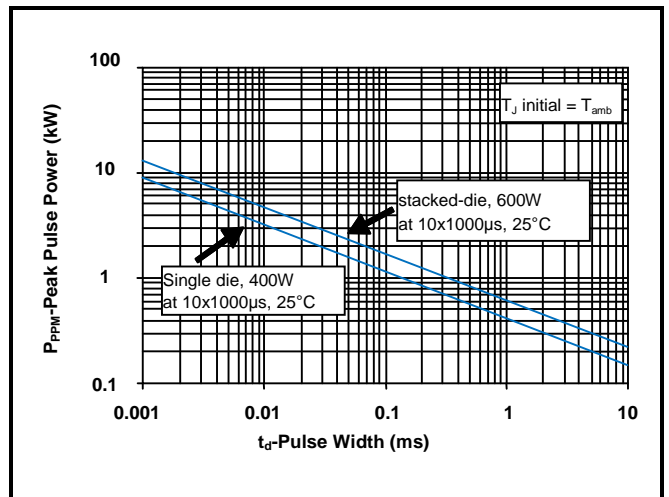

Figure 2 - Peak Pulse Power Rating Curve



Ratings and Characteristic Curves ($T_A=25^\circ\text{C}$ unless otherwise noted)

Figure 3 - Pulse Derating Curve

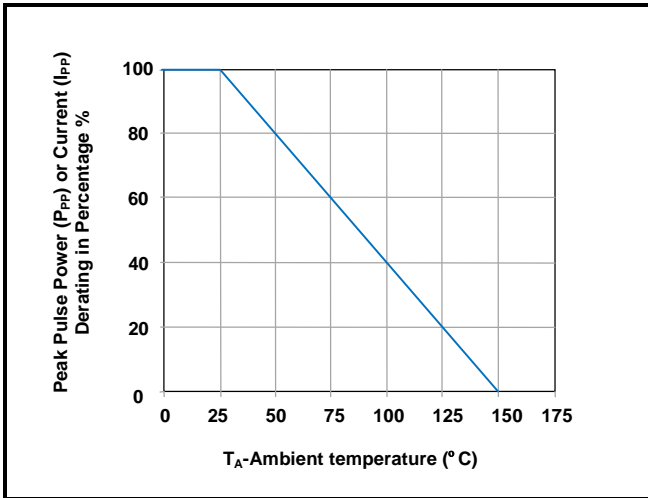

Figure 4 - Pulse Waveform

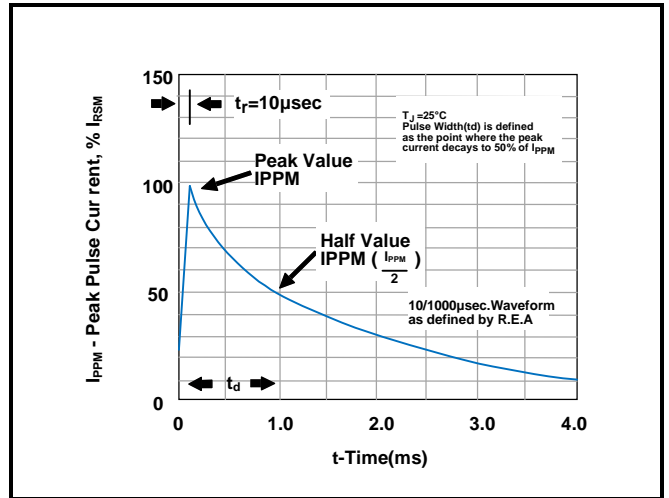

Figure 5 - Typical Junction Capacitance

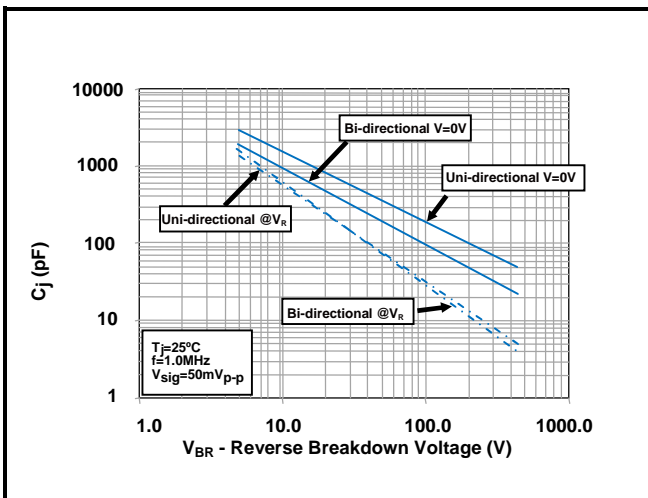

Figure 6 - Steady State Power Derating Curve

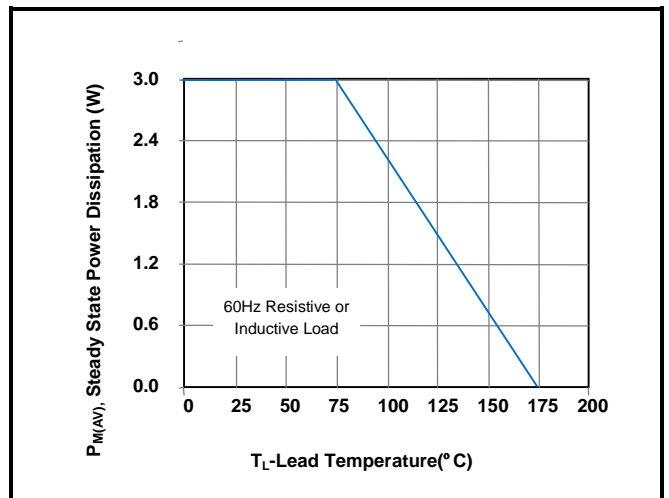
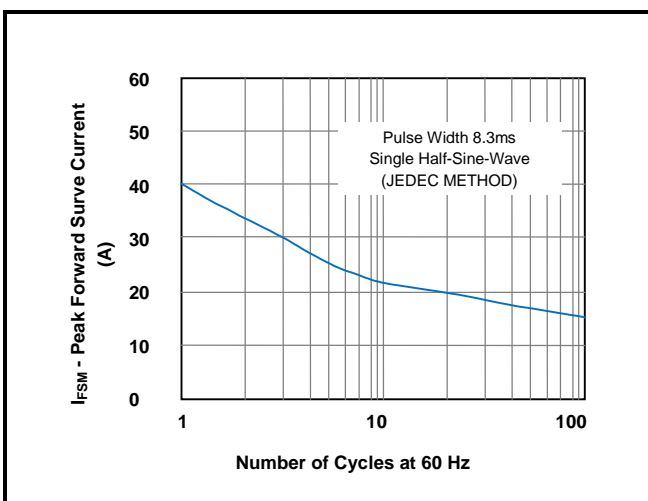
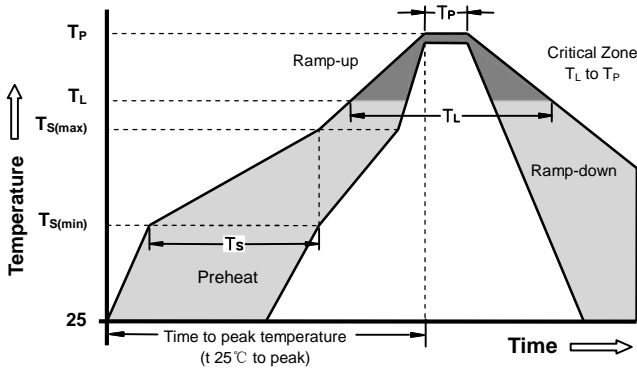

Figure 7 - Maximum Non-Repetitive Surge Current



Soldering Parameters - Reflow Soldering (Surface Mount Devices)



Reflow Condition		Pb - Free assembly
Pre Heat	-Temperature Min ($T_{s(min)}$)	150°C
	-Temperature Max ($T_{s(max)}$)	200°C
	- Time (min to max) (t_s)	60 -180 Seconds
Average ramp up rate (Liquids Temp T_L) to peak		3°C/second max
$T_{s(max)}$ to T_L - Ramp-up Rate		3°C/second max
Reflow	- Temperature (T_L) (Liquids)	217°C
	- Time (min to max) (t_s)	60 -150 Seconds
Peak Temperature (T_P)		260 +0/-5°C
Time within 5°C of actual peak Temperature (t_p)		20 - 40 Seconds
Ramp-down Rate		6°C/second max
Time 25°C to peak Temperature (T_P)		8 minutes Max
Do not exceed		260°C

Part Marking System

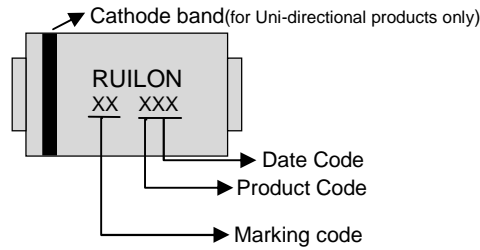

Dimensions

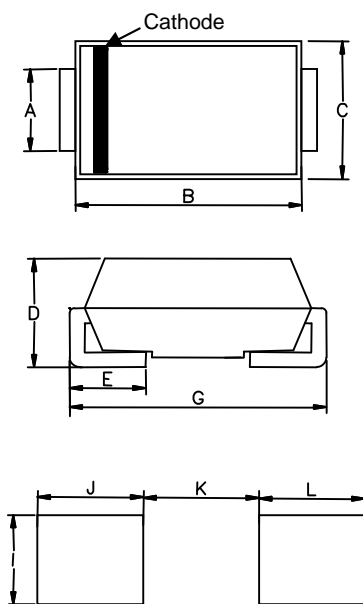

DIM	Millimeters		Inches	
	Min	Max	Min	Max
A	1.25	1.80	0.049	0.071
B	3.99	4.60	0.157	0.181
C	2.50	2.80	0.100	0.110
D	1.90	2.45	0.075	0.096
E	0.76	1.52	0.030	0.060
G	4.80	5.30	0.189	0.209
I	1.800	-	0.070	-
J	2.100	-	0.082	-
K	-	2.300	-	0.090
L	2.100	-	0.082	-



Taping and Reel Specifications

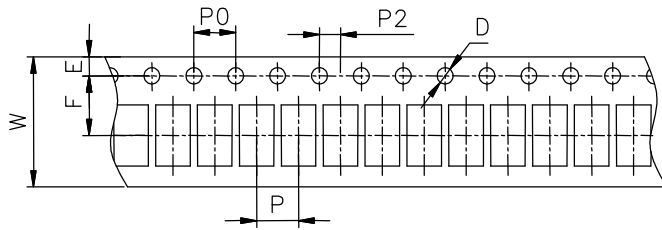

Symbol	Millimeters	Inches
W	12±0.3	0.472±0.012
P	4±0.1	0.157±0.004
F	5.5±0.1	0.217±0.004
E	1.75±0.1	0.069±0.004
D	1.5+0.1/-0.0	0.059+0.004/-0.0
P0	4±0.1	0.157±0.004
P2	2±0.1	0.079±0.004
D0	16.7±0.15	0.657±0.006
D1	178±2	7.007±0.079
D2	59.6+1/-2	2.346+0.039/-0.079
W1	12.64±0.4	0.498±0.016

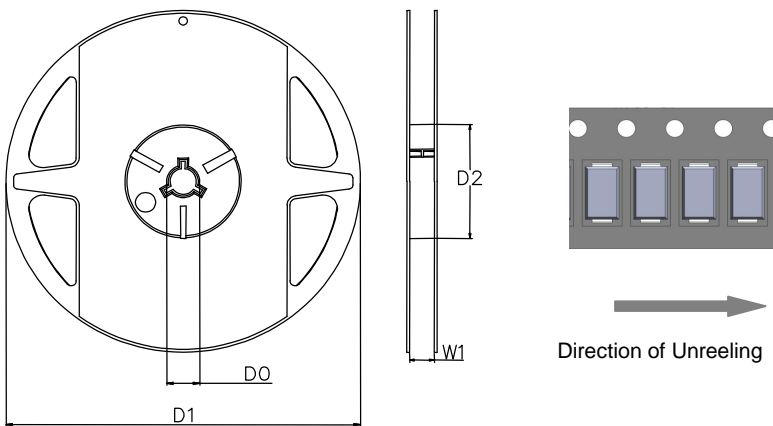

Part Number	Component package	Quantity	Packaging option	Packaging specification
SMAJXXXA/CA	DO-214AC(SMA)	2000	Tape&Reel-12mm/7"tape	EIA STD RS-481



X-ON Electronics

Largest Supplier of Electrical and Electronic Components

Click to view similar products for [ESD Suppressors / TVS Diodes](#) category:

Click to view products by [Ruilongyuan](#) manufacturer:

Other Similar products are found below :

[60KS200C](#) [D18V0L1B2LP-7B](#) [D5V0F4U5P5-7](#) [NTE4902](#) [P4KE27CA](#) [P6KE11CA](#) [P6KE8.2A](#) [SA60CA](#) [SA64CA](#) [SMBJ12CATR](#)
[SMBJ33CATR](#) [SMBJ6.5A](#) [SMBJ8.0A](#) [ESD101-B1-02ELS E6327](#) [ESD112-B1-02EL E6327](#) [ESD7451N2T5G](#) [19180-510](#) [CPDT-5V0USP-](#)
[HF](#) [3.0SMCJ33CA-F](#) [3.0SMCJ36A-F](#) [HSPC16701B02TP](#) [JANTX1N6126A](#) [D3V3Q1B2DLP3-7](#) [D55V0M1B2WS-7](#) [SCM1293A-04SO](#)
[ESD200-B1-CSP0201 E6327](#) [SM12-7](#) [CEN955 W/DATA](#) [VESD12A1A-HD1-GS08](#) [CPDQC5V0-HF](#) [D1213A-01LP4-7B](#) [ESD101-B1-02EL](#)
[E6327](#) [AOZ8808DI-03](#) [5KP15A](#) [5KP48A](#) [5KP90A](#) [ESD3V3D7-TP](#) [15KPA36A-LF](#) [P4KE56CA](#) [P4KE68A](#) [P4KE91CATR](#) [P6KE120A](#)
[P6KE13CA](#) [P6KE43CA](#) [P6KE6.8CA](#) [P6KE8.2](#) [P6SMBJ20CA](#) [JANTX1N6072A](#) [SR2835ESKG](#) [SA90CA](#)