

Mechanical Data

- Case: Molded plastic
- Epoxy: UL 94V-0 rate flame retardant
- Lead: Solderable per MIL-STD-750, method 2026
- Polarity: Color band denotes cathode end except Bipolar
- Mounting position: Any

Features

- Fast response time
- Low incremental surge resistance
- Matte tin lead-free Plated
- Halogen free and RoHS compliant
- Typical IR less than 1μA above 10V
- Compatible with industrial standard package DO-214AA
- For surface mounted applications to optimize board space
- 600W peak pulse power capability with at 10/1000μs waveform, repetition rate (duty cycle): 0.01%
- High temperature soldering:260°C/10 seconds at terminals

Electrical symbol

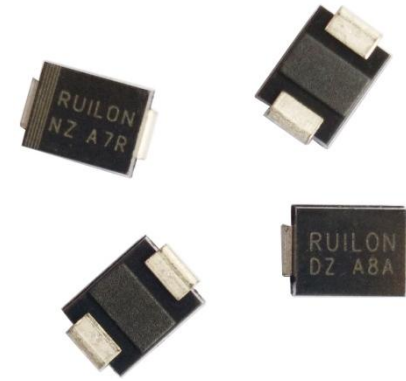
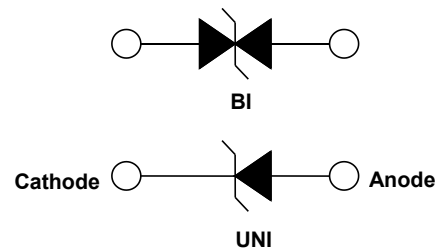

Part Number Code

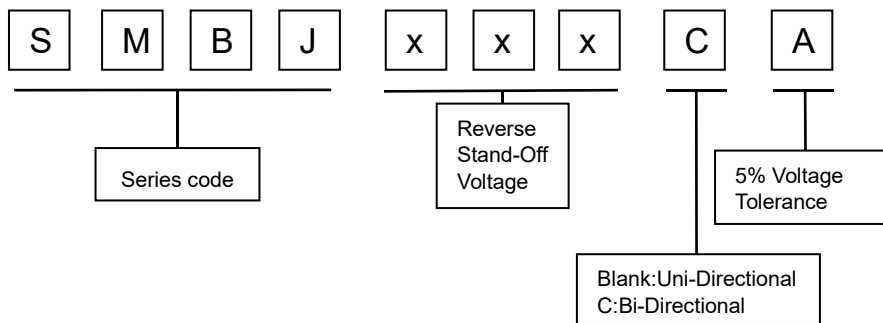

Mechanical Characteristics

Rating	Symbol	Value	Units
Peak Pulse Power Dissipation at T _A =25°C by 10/1000μs Waveform (Fig.2)(Note 1), (Note 2)	P _{PP}	600	W
Power Dissipation on Infinite Heat Sink at T _L =75°C(Fig.6)	P _D	5.0	W
Peak Forward Surge Current, 8.3ms Single Half Sine Wave (Note 3)	I _{FSM}	100	A
Maximum instantaneous forward voltage at 50 A for unidirectional only ⁽³⁾	V _F	3.5/5.0	V
Operating Temperature Range Storage Temperature Range	T _J , T _{STG}	-55 to 150	°C

Notes:

1. Non-repetitive current pulse, per Fig.4 and derated above T_A=25° C per Fig. 3.
2. Mounted on 5.0x5.0mm copper pad to each terminal.
3. Measured on 8.3ms single half sine wave or equivalent square wave for unidirectional device only, duty cycle=4 per minute maximum.

Electrical Characteristics

Type Number		Marking		Reverse Stand-Off Voltage	Breakdown Voltage		Test Current	Max. Clamping Voltage 10/1000µs	Max. Peak Pulse Current 10/1000µs	Reverse Leakage	
					V _{RWM}	V _{BR @IT}					
						Min					Max
UNI	BI	UNI	BI	V	V	V	mA	V	A	µA	
SMBJ5.0A	SMBJ5.0CA	KE	AE	5.0	6.40	7.07	10	9.2	65.2	500	
SMBJ6.0A	SMBJ6.0CA	KG	AG	6.0	6.67	7.37	10	10.3	58.3	300	
SMBJ6.5A	SMBJ6.5CA	KK	AK	6.5	7.22	7.98	10	11.2	53.6	200	
SMBJ7.0A	SMBJ7.0CA	KM	AM	7.0	7.78	8.60	10	12.0	50.0	100	
SMBJ7.5A	SMBJ7.5CA	KP	AP	7.5	8.33	9.21	1	12.9	46.6	50	
SMBJ8.0A	SMBJ8.0CA	KR	AR	8.0	8.89	9.83	1	13.6	44.2	50	
SMBJ8.5A	SMBJ8.5CA	KT	AT	8.5	9.44	10.4	1	14.4	41.7	30	
SMBJ9.0A	SMBJ9.0CA	KV	AV	9.0	10.00	11.1	1	15.4	39.0	30	
SMBJ10A	SMBJ10CA	KX	AX	10.0	11.10	12.3	1	17.0	35.3	3	
SMBJ11A	SMBJ11CA	KZ	AZ	11.0	12.20	13.5	1	18.2	33.0	1	
SMBJ12A	SMBJ12CA	LE	BE	12.0	13.30	14.7	1	19.9	30.2	1	
SMBJ13A	SMBJ13CA	LG	BG	13.0	14.40	15.9	1	21.5	28.0	1	
SMBJ14A	SMBJ14CA	LK	BK	14.0	15.60	17.2	1	23.2	25.9	1	
SMBJ15A	SMBJ15CA	LM	BM	15.0	16.70	18.5	1	24.4	24.6	1	
SMBJ16A	SMBJ16CA	LP	BP	16.0	17.80	19.7	1	26.0	23.1	1	
SMBJ17A	SMBJ17CA	LR	BR	17.0	18.90	20.9	1	27.6	21.8	1	
SMBJ18A	SMBJ18CA	LT	BT	18.0	20.00	22.1	1	29.2	20.6	1	
SMBJ20A	SMBJ20CA	LV	BV	20.0	22.20	24.5	1	32.4	18.6	1	
SMBJ22A	SMBJ22CA	LX	BX	22.0	24.40	26.9	1	35.5	16.9	1	
SMBJ24A	SMBJ24CA	LZ	BZ	24.0	26.70	29.5	1	38.9	15.5	1	
SMBJ26A	SMBJ26CA	ME	CE	26.0	28.90	31.9	1	42.1	14.3	1	
SMBJ28A	SMBJ28CA	MG	CG	28.0	31.10	34.4	1	45.4	13.3	1	
SMBJ30A	SMBJ30CA	MK	CK	30.0	33.30	36.8	1	48.4	12.4	1	
SMBJ33A	SMBJ33CA	MM	CM	33.0	36.70	40.6	1	53.3	11.3	1	
SMBJ36A	SMBJ36CA	MP	CP	36.0	40.00	44.2	1	58.1	10.4	1	
SMBJ40A	SMBJ40CA	MR	CR	40.0	44.40	49.1	1	64.5	9.3	1	
SMBJ43A	SMBJ43CA	MT	CT	43.0	47.80	52.8	1	69.4	8.7	1	
SMBJ45A	SMBJ45CA	MV	CV	45.0	50.00	55.3	1	72.7	8.3	1	
SMBJ48A	SMBJ48CA	MX	CX	48.0	53.30	58.9	1	77.4	7.8	1	
SMBJ51A	SMBJ51CA	MZ	CZ	51.0	56.70	62.7	1	82.4	7.3	1	

Electrical Characteristics

Type Number		Marking		Reverse Stand-Off Voltage	Breakdown Voltage		Test Current	Max. Clamping Voltage 10/1000 μ s	Max. Peak Pulse Current 10/1000 μ s	Reverse Leakage
					V _{BR @IT}					
				V _{RWM}	Min	Max	mA	V	A	μ A
UNI	BI	UNI	BI	V	V	V	mA	V	A	μ A
SMBJ54A	SMBJ54CA	NE	DE	54.0	60.00	66.3	1	87.1	6.9	1
SMBJ58A	SMBJ58CA	NG	DG	58.0	64.40	71.2	1	93.6	6.5	1
SMBJ60A	SMBJ60CA	NK	DK	60.0	66.70	73.7	1	96.8	6.2	1
SMBJ64A	SMBJ64CA	NM	DM	64.0	71.10	78.6	1	103.0	5.9	1
SMBJ70A	SMBJ70CA	NP	DP	70.0	77.80	86.0	1	113.0	5.3	1
SMBJ75A	SMBJ75CA	NR	DR	75.0	83.30	92.1	1	121.0	5.0	1
SMBJ78A	SMBJ78CA	NT	DT	78.0	86.70	95.8	1	126.0	4.8	1
SMBJ85A	SMBJ85CA	NV	DV	85.0	94.40	104.0	1	137.0	4.4	1
SMBJ90A	SMBJ90CA	NX	DX	90.0	100.0	111.0	1	146.0	4.1	1
SMBJ100A	SMBJ100CA	NZ	DZ	100.0	111.0	123.0	1	162.0	3.7	1
SMBJ110A	SMBJ110CA	PE	EE	110.0	122.0	135.0	1	177.0	3.4	1
SMBJ120A	SMBJ120CA	PG	EG	120.0	133.0	147.0	1	193.0	3.1	1
SMBJ130A	SMBJ130CA	PK	EK	130.0	144.0	159.0	1	209.0	2.9	1
SMBJ150A	SMBJ150CA	PM	EM	150.0	167.0	185.0	1	243.0	2.5	1
SMBJ160A	SMBJ160CA	PP	EP	160.0	178.0	197.0	1	259.0	2.3	1
SMBJ170A	SMBJ170CA	PR	ER	170.0	189.0	209.0	1	275.0	2.2	1
SMBJ180A	SMBJ180CA	PT	ET	180.0	201.0	222.0	1	292.0	2.1	1
SMBJ190A	SMBJ190CA	PV	EV	190.0	209.0	243.0	1	306.0	2.0	1
SMBJ200A	SMBJ200CA	PX	EX	200.0	224.0	247.0	1	324.0	1.9	1
SMBJ210A	SMBJ210CA	PZ	EZ	210.0	231.0	268.0	1	340.0	1.8	1
SMBJ220A	SMBJ220CA	QE	FE	220.0	246.0	272.0	1	356.0	1.7	1
SMBJ250A	SMBJ250CA	QG	FG	250.0	279.0	309.0	1	405.0	1.5	1
SMBJ300A	SMBJ300CA	QK	FK	300.0	335.0	371.0	1	486.0	1.3	1
SMBJ350A	SMBJ350CA	QM	FM	350.0	391.0	432.0	1	567.0	1.1	1
SMBJ400A	SMBJ400CA	QP	FP	400.0	447.0	494.0	1	648.0	0.9	1
SMBJ440A	SMBJ440CA	QR	FR	440.0	492.0	543.0	1	713.0	0.9	1
SMBJ500A	SMBJ500CA	QV	FV	500.0	558.0	618.0	1	762.0	0.8	1

Notes: For bidirectional type having V_R of 10V and less, the I_R limit is double.

I-V Curve Characteristics

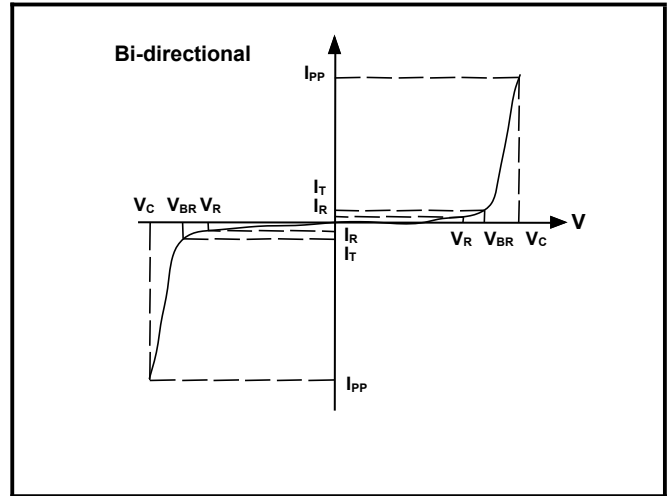
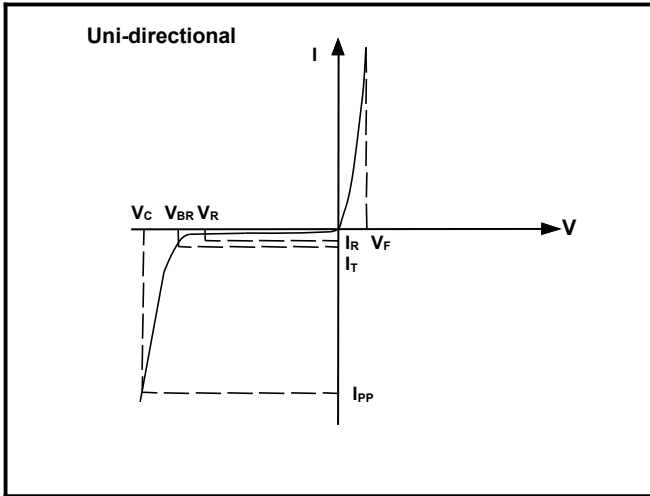

P_{PPM} Peak Pulse Power Dissipation -- Max power dissipation

V_R Stand-off Voltage -- Maximum voltage that can be applied to the TVS without operation

V_{BR} Breakdown Voltage -- Maximum voltage that flows through the TVS at a specified test current (I_T)

V_C Clamping Voltage -- Peak voltage measured across the TVS at a specified I_{ppm} (peak impulse current)

I_R Reverse Leakage Current -- Current measured at V_R

V_F Forward Voltage Drop for Uni-directional

Ratings and Characteristic Curves ($T_A=25^\circ C$ unless otherwise noted)

Figure 1 - TVS Transients Clamping Waveform

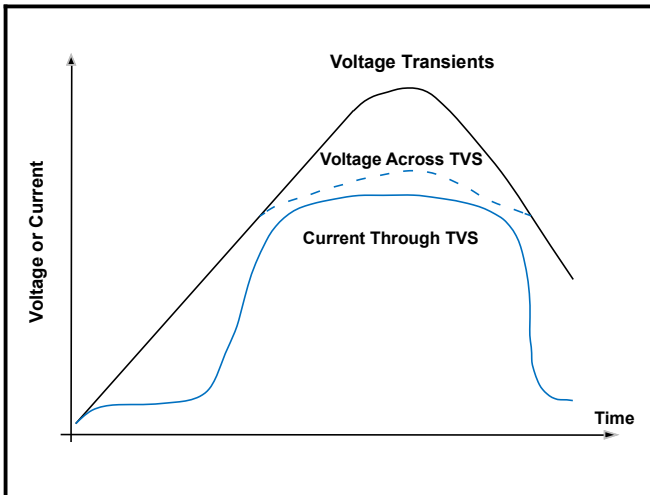
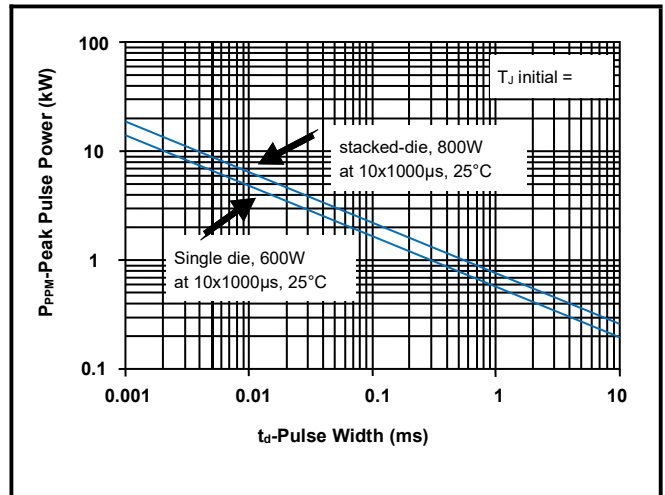

Figure 2 - Peak Pulse Power Rating Curve



Ratings and Characteristic Curves (TA=25°C unless otherwise noted)

Figure 3 - Pulse Derating Curve

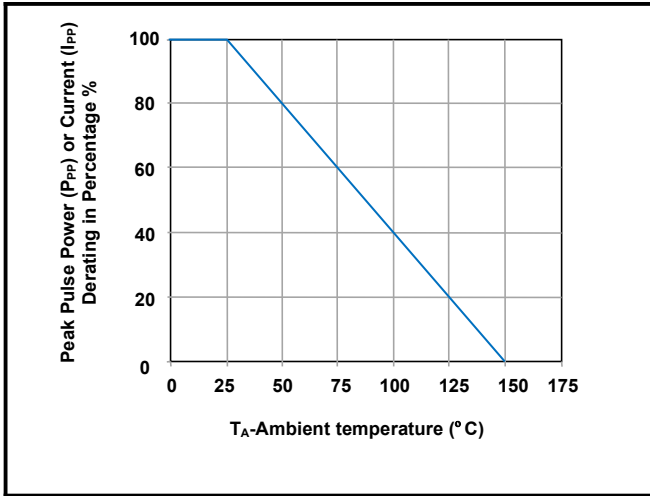

Figure 4 - Pulse Waveform

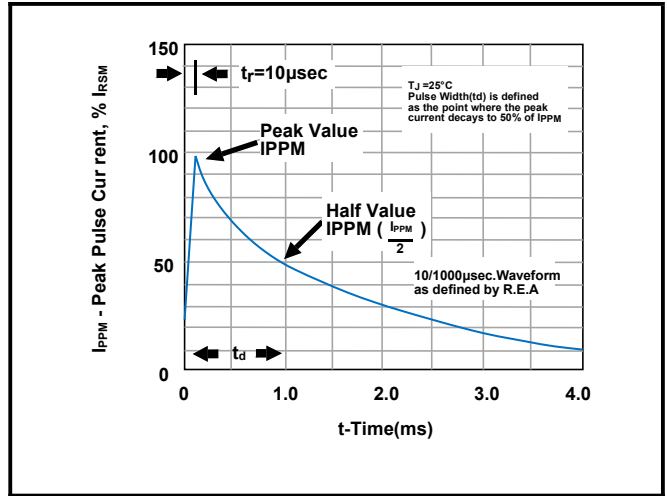

Figure 5 - Typical Junction Capacitance

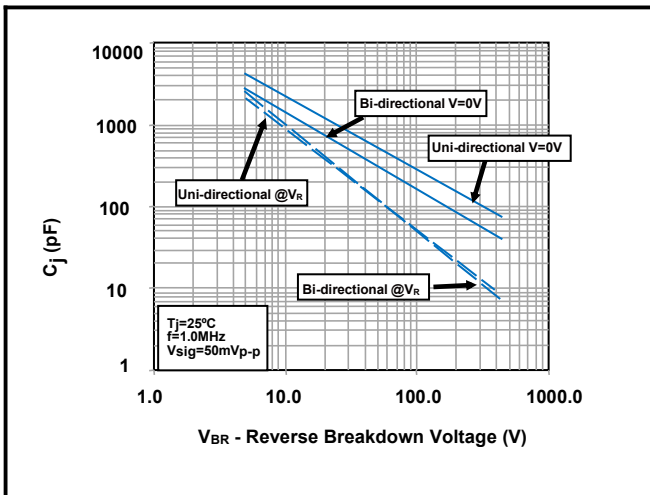

Figure 6 - Steady State Power Derating Curve

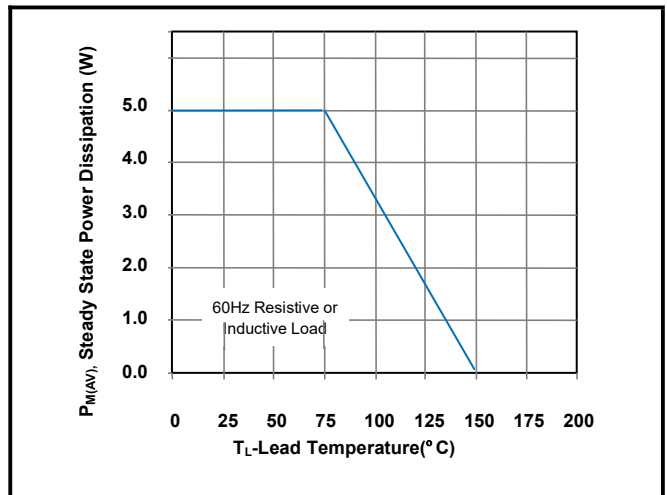
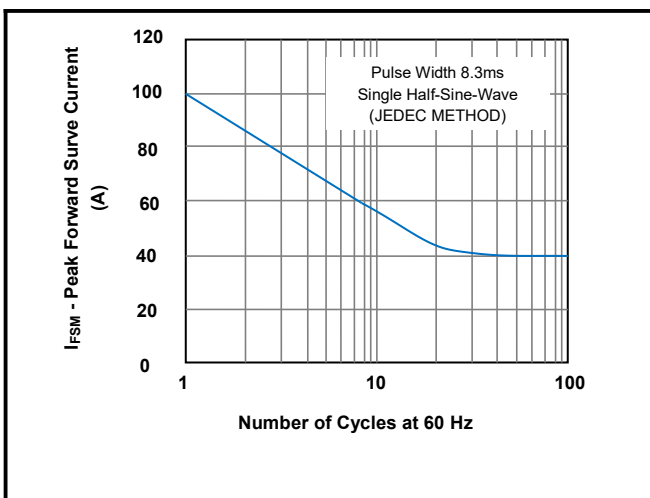
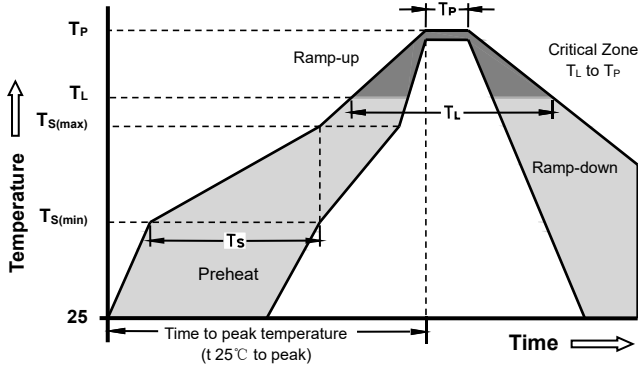

Figure 7 - Maximum Non-Repetitive Surge Current



Soldering Parameters - Reflow Soldering (Surface Mount Devices)



Reflow Condition		Pb - Free assembly
Pre Heat	-Temperature Min ($T_{s(min)}$)	150°C
	-Temperature Max ($T_{s(max)}$)	200°C
	- Time (min to max) (t_s)	60 -180 Seconds
Average ramp up rate (Liquids Temp T_L to peak)		3°C/second max
$T_{s(max)}$ to T_L - Ramp-up Rate		3°C/second max
Reflow	- Temperature (T_L) (Liquids)	217°C
	- Time (min to max) (t_s)	60 -150 Seconds
Peak Temperature (T_P)		260 +0/-5°C
Time within 5°C of actual peak Temperature (t_p)		20 - 40 Seconds
Ramp-down Rate		6°C/second max
Time 25°C to peak Temperature (T_P)		8 minutes Max
Do not exceed		260°C

Part Marking System

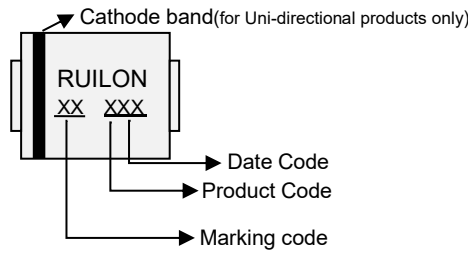

Dimensions

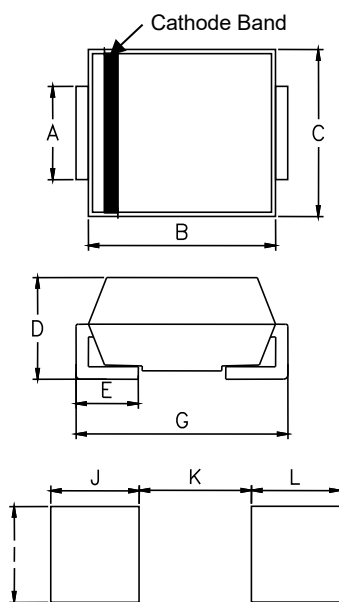

DIM	Millimeters		Inches	
	Min	Max	Min	Max
A	1.80	2.20	0.071	0.086
B	4.05	4.65	0.160	0.183
C	3.30	3.94	0.130	0.155
D	2.05	2.45	0.081	0.096
E	0.76	1.52	0.030	0.060
G	5.11	5.59	0.201	0.220
I	2.26	-	0.089	-
J	2.16	-	0.085	-
K	-	2.74	-	0.107
L	2.16	-	0.085	-

Taping and Reel Specifications

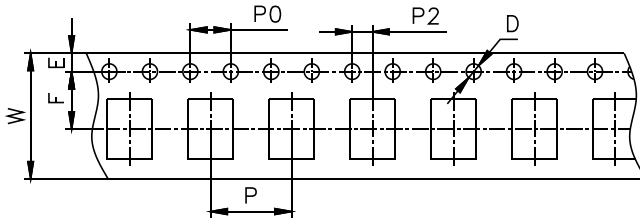

Symbol	Millimeters	Inches
W	12±0.3	0.472±0.012
P	8±0.1	0.315±0.004
F	5.5±0.1	0.217±0.004
E	1.75±0.1	0.069±0.004
D	1.5+0.1/-0.0	0.059+0.004/-0.0
P0	4±0.1	0.157±0.004
P2	2±0.1	0.079±0.004
D0	16.7±0.15	0.657±0.006
D1	330.2±2	13.0±0.079
D2	59.6+1/-2	2.346+0.039/-0.079
W1	12.64±0.4	0.498±0.016

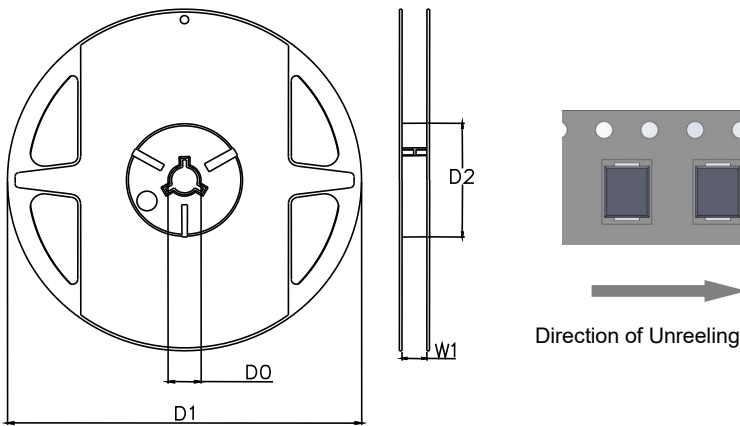

Part Number	Component package	Quantity	Packaging option	Packaging specification
SMBJXXXA/CA	DO-214AA(SMB)	3000PCS	Tape&Reel-12mm/13"tape	EIA STD RS-481

X-ON Electronics

Largest Supplier of Electrical and Electronic Components

Click to view similar products for [ESD Suppressors / TVS Diodes](#) category:

Click to view products by [Ruilongyuan](#) manufacturer:

Other Similar products are found below :

[60KS200C](#) [D18V0L1B2LP-7B](#) [D5V0F4U5P5-7](#) [NTE4902](#) [P4KE27CA](#) [P6KE11CA](#) [P6KE8.2A](#) [SA60CA](#) [SA64CA](#) [SMBJ12CATR](#)
[SMBJ33CATR](#) [SMBJ6.5A](#) [SMBJ8.0A](#) [ESD101-B1-02ELS](#) [E6327](#) [ESD112-B1-02EL](#) [E6327](#) [ESD7451N2T5G](#) [19180-510](#) [CPDT-5V0USP-](#)
[HF](#) [3.0SMCJ33CA-F](#) [3.0SMCJ36A-F](#) [HSPC16701B02TP](#) [JANTX1N6126A](#) [D3V3Q1B2DLP3-7](#) [D55V0M1B2WS-7](#) [SCM1293A-04SO](#)
[ESD200-B1-CSP0201](#) [E6327](#) [SM12-7](#) [CEN955](#) [W/DATA](#) [VESD12A1A-HD1-GS08](#) [CPDQC5V0-HF](#) [D1213A-01LP4-7B](#) [ESD101-B1-02EL](#)
[E6327](#) [AOZ8808DI-03](#) [5KP15A](#) [5KP48A](#) [5KP90A](#) [ESD3V3D7-TP](#) [15KPA36A-LF](#) [P4KE56CA](#) [P4KE68A](#) [P4KE91CATR](#) [P6KE120A](#)
[P6KE13CA](#) [P6KE43CA](#) [P6KE6.8CA](#) [P6KE8.2](#) [P6SMBJ20CA](#) [JANTX1N6072A](#) [SR2835ESKG](#) [SA90CA](#)