

Dual Bidirectional I²C-Bus and SMBus Voltage-Level Translator

FEATURES

- 1.0V to 5.5V V_{REF1} and 1.8V to 5.5V V_{REF2} ($V_{REF1} < V_{REF2}$)
- 2-Bit Bidirectional Translator for SDA and SCL Lines in Mixed-Mode I²C Applications
- Compatible with I²C and SMBus
- Less Than 1.5ns Maximum Propagation Delay to Accommodate Standard-Mode and Fast-Mode I²C Devices and Multiple Masters
- Provides bidirectional voltage translation with no direction pin
- Allows Voltage-Level Translation Between
 -1.0V V_{REF1} and 1.8V, 2.5V, 3.3V or 5V V_{REF2}
 -1.2V V_{REF1} and 1.8V, 2.5V, 3.3V or 5V V_{REF2}
 -1.8V V_{REF1} and 2.5V, 3.3V or 5V V_{REF2}
 -2.5V V_{REF1} and 3.3V or 5V V_{REF2}
 -3.3V V_{REF1} and 5V V_{REF2}
- Low 3.5Ω ON-State Connection Between Input and Output Ports Provides Less Signal Distortion
- Open-Drain I²C I/O Ports (SCL1, SDA1, SCL2 and SDA2)
- High-Impedance SCL1, SDA1, SCL2 and SDA2 Pins for EN = Low
- Lock-Up-Free Operation for Isolation When EN = Low
- 5V Tolerant I²C I/O Ports to Support Mixed-Mode Signal Operation
- Extended Temperature: -40°C to +85°C

APPLICATIONS

- I²C, SMBus, PMBus, MDIO, UART, Low-Speed SDIO, GPIO, and Other Two-Signal Interfaces
- Automotive Head Units
- Automotive Instrument Clusters
- Automotive Driver Assistance Cameras

DESCRIPTION

This dual bidirectional I²C and SMBus voltage-level translator, with an enable (EN) input, is operational from 1.0V to 5.5V V_{REF1} and 1.8V to 5.5V V_{REF2} .

The RS0302 allows bidirectional voltage translations between 1.0V and 5V without the use of a direction pin. The low ON-state resistance (R_{ON}) of the switch allows connections to be made with minimal propagation delay. When EN is HIGH, the translator switch is ON, and the SCL1 and SDA1 I/O are connected to the SCL2 and SDA2 I/O, respectively, allowing bidirectional data flow between ports. When EN is LOW, the translator switch is off, and a high-impedance state exists between ports.

In I²C applications, the bus capacitance limit of 400 pF restricts the number of devices and bus length. Using the RS0302 enables the system designer to isolate two halves of a bus; thus, more I²C devices or longer trace length can be accommodated.

The RS0302 also can be used to run two buses, one at 400kHz operating frequency and the other at 100kHz operating frequency. If the two buses are operating at different frequencies, the 100kHz bus must be isolated when the 400kHz operation of the other bus is required. If the master is running at 400kHz, the maximum system operating frequency may be less than 400kHz because of the delays added by the repeater.

The RS0302 are available in green SOT23-8 and DFN1.4x1.0-8L packages. It operates over an ambient temperature range of -40°C to +85°C.

Device Information ⁽¹⁾

PART NUMBER	PACKAGE	BODY SIZE (NOM)
RS0302	SOT23-8	1.60mmx2.92mm
RS0302	DFN1.4x1.0-8L	1.00mmx1.40mm

(1) For all available packages, see the orderable addendum at the end of the data sheet.

Revision History

Note: Page numbers for previous revisions may differ from page numbers in the current version.

VERSION	Change Date	Change Item
A.0	2021/01/20	initial version completed
A.1	2021/09/15	Added DFN1.4x1.0-8L package
A.2	2022/01/13	Update the Minimum operating voltage of V_{REF1}

Functional Block Diagram

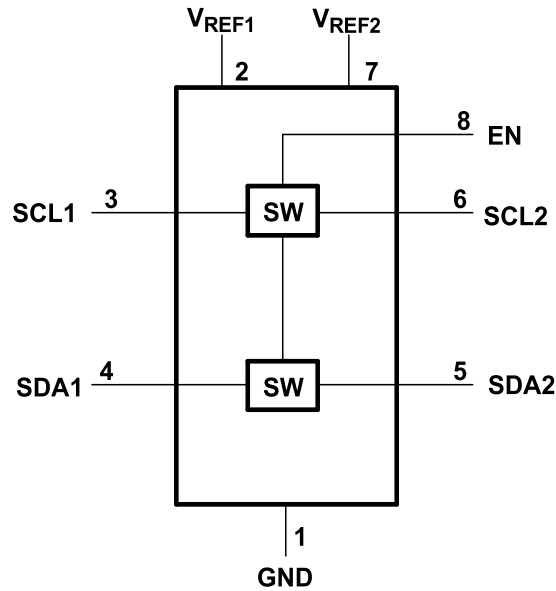

Figure 1. Function Block Diagram

Function table

INPUT EN ⁽¹⁾	FUNCTION
H	Logic Lows are propagated from one side to the other, Logic Highs blocked (independent pull up resistors passively drive the line high)
L	Disconnect

(1) The SCL switch conducts if EN is ≥ 0.6 V higher than SCL1 or SCL2. The same is true of SDA.

PIN CONFIGURATIONS AND FUNCTIONS

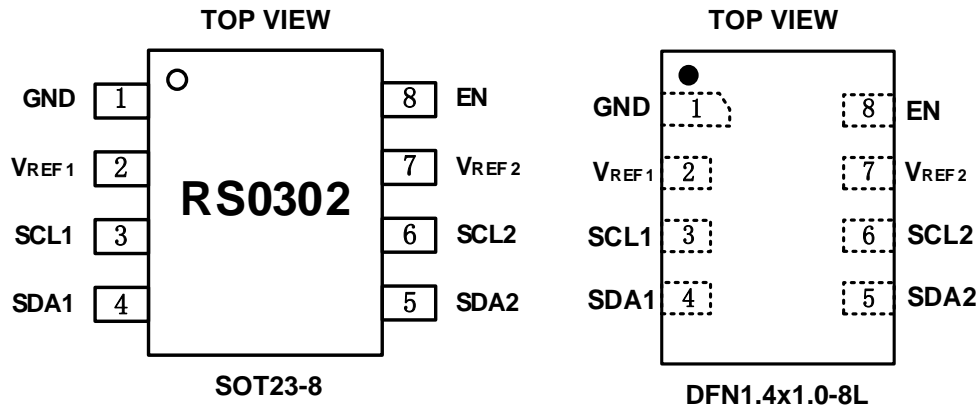

PIN DESCRIPTION

PIN	NAME	TYPE ⁽¹⁾	FUNCTION
SOT23-8/DFN1.4x1.0-8L			
1	GND	–	Ground
2	V _{REF1}	I	Low-voltage-side reference supply voltage for SCL1 and SDA1
3	SCL1	I/O	Serial clock, low-voltage side
4	SDA1	I/O	Serial data, low-voltage side
5	SDA2	I/O	Serial data, high-voltage side
6	SCL2	I/O	Serial clock, high-voltage side
7	V _{REF2}	I	High-voltage-side reference supply voltage for SCL2 and SDA2
8	EN	I	Switch enable input

(1) I=input, O=output, I/O=input and output

SPECIFICATIONS

Absolute Maximum Ratings

Over operating free-air temperature range (unless otherwise noted) ⁽¹⁾

SYMBOL	PARAMETER		MIN	MAX	UNIT
V _{REF1}	DC reference voltage		-0.5	7	V
V _{REF2}	DC reference voltage		-0.5	7	V
V _I ⁽²⁾	Input Voltage		-0.5	7	V
V _{I/O} ⁽²⁾	Input/output		-0.5	7	V
I _{ch}	Continuous Channel current			128	mA
I _{IK}	Input clamp current	V _I <0		-50	mA
T _{J(max)}	Maximum junction temperature			125	°C
T _{stg}	Storage temperature		-65	+150	°C

(1) Stresses beyond those listed under *Absolute Maximum Ratings* may cause permanent damage to the device. These are stress ratings only, which do not imply functional operation of the device at these or any other conditions beyond those indicated under *Recommended Operating Conditions*. Exposure to absolute-maximum-rated conditions for extended periods may affect device reliability.

(2) The input and output negative-voltage ratings may be exceeded if the input and output current ratings are observed.

ESD Ratings

			VALUE	UNIT
V _(ESD)	Electrostatic discharge	Human-body model (HBM)	±7000	V
		Machine model (MM)	±400	

Recommended Operating Conditions

		MIN	TYP	MAX	UNIT
Input/output voltage (V _{I/O})	SCL1, SDA1, SCL2, SDA2	0		5.5	V
Reference voltage (V _{REF1}) ⁽¹⁾		0		5.5	V
Reference voltage (V _{REF2}) ⁽¹⁾		0		5.5	V
Enable input voltage (EN)		0		5.5	V
Pass switch current (I _{PASS})				64	mA
Operating ambient temperature (T _A)		-40		85	°C

(1) To support translation, V_{REF1} supports 1.0 V to V_{REF2} - 0.6 V. V_{REF2} must be between V_{REF1} + 0.6 V to 5.5 V. See Typical Application for more information.

PACKAGE/ORDERING INFORMATION

PRODUCT	ORDERING NUMBER	TEMPERATURE RANGE	PACKAGE LEAD	PACKAGE MARKING ⁽¹⁾	MSL ⁽²⁾	PACKAGE OPTION
RS0302	RS0302YH8	-40°C ~+85°C	SOT23-8	0302	MSL3	Tape and Reel,3000
RS0302	RS0302YUTDS8	-40°C ~+85°C	DFN1.4x1.0-8L	0302	MSL3	Tape and Reel,5000

NOTE:

- (1) There may be additional marking, which relates to the lot trace code information(data code and vendor code), the logo or the environmental category on the device.
- (2) MSL, The Moisture Sensitivity Level rating according to the JEDEC industry standard classifications.

Electrical Characteristics

over recommended operating ambient temperature range (unless otherwise noted) ⁽¹⁾

PARAMETER		CONDITIONS		MIN	TYP	MAX	UNIT
V_{IK}	Input clamp voltage	$I_I = -18\text{mA}$	$EN = 0\text{V}$			-1.2	V
I_I	Input leakage current	$V_I = 5\text{V}$	$EN = 0\text{V}$			5	μA
$C_i(EN)$	Input capacitance	$V_I = 3\text{V}$ or 0V			10		pF
$C_i(off)$	Off capacitance	SCLn, SDA _n	$V_o = 3\text{V}$ or 0V	$EN = 0\text{V}$	4	6	pF
$C_i(on)$	On capacitance	SCLn, SDA _n	$V_o = 3\text{V}$ or 0V	$EN = 3\text{V}$	10.3	12.5	pF
$R_{ON}^{(2)}$	ON-state resistance	SCLn, SDA _n	$V_I = 0\text{V}, I_o = 64\text{mA}$	$EN = 4.5\text{V}$	1.8		Ω
				$EN = 3\text{V}$	2.3		
				$EN = 2.3\text{V}$	2.9		
			$V_I = 0\text{V}, I_o = 15\text{mA}$	$EN = 1.5\text{V}$	3.9		
			$V_I = 2.4\text{V}^{(3)}, I_o = 15\text{mA}$	$EN = 4.5\text{V}$	4		
				$EN = 3\text{V}$	56		
$V_I = 1.7\text{V}^{(3)}, I_o = 15\text{mA}$	$EN = 2.3\text{V}$	49					

(1) All typical values are at $T_A = 25^\circ\text{C}$.

(2) Measured by the voltage drop between the SCL1 and SCL2, or SDA1 and SDA2 terminals, at the indicated current through the switch. ON-state resistance is determined by the lowest voltage of the two terminals.

(3) Measured in current sink configuration only

Switching Characteristics AC Performance: Translating Down ⁽¹⁾, $EN = 3.3\text{V}$

over recommended operating ambient temperature range, $EN = 3.3\text{V}$, $V_{IH} = 3.3\text{V}$, $V_{IL} = 0$, $V_M = 1.15\text{V}$ (unless otherwise noted)

PARAMETER	FROM (INPUT)	TO (OUTPUT)	$C_L = 50\text{pF}$		$C_L = 30\text{pF}$		$C_L = 15\text{pF}$		UNIT
			MIN	MAX	MIN	MAX	MIN	MAX	
t_{PLH}	SCL2 or SDA2	SCL1 or SDA1	0	0.8	0	0.6	0	0.4	ns
t_{PHL}			0	0.6	0	0.6	0	0.5	ns

(1) Translating down: the high-voltage side driving toward the low-voltage side

Switching Characteristics AC Performance: Translating Down ⁽¹⁾, $EN = 2.5\text{V}$

over recommended operating free-air temperature range, $EN = 2.5\text{V}$, $V_{IH} = 3.3\text{V}$, $V_{IL} = 0$, $V_M = 0.75\text{V}$ (unless otherwise noted)

PARAMETER	FROM (INPUT)	TO (OUTPUT)	$C_L = 50\text{pF}$		$C_L = 30\text{pF}$		$C_L = 15\text{pF}$		UNIT
			MIN	MAX	MIN	MAX	MIN	MAX	
t_{PLH}	SCL2 or SDA2	SCL1 or SDA1	0	1.0	0	0.7	0	0.6	ns
t_{PHL}			0	0.6	0	0.6	0	0.8	ns

(1) Translating down: the high-voltage side driving toward the low-voltage side

Switching Characteristics AC Performance: Translating Up ⁽¹⁾, EN=3.3V

over recommended operating free-air temperature range, EN = 3.3 V, $V_{IH} = 2.3$ V, $V_{IL} = 0$, $V_T = 3.3$ V, $V_M = 1.15$ V, $R_L = 300\Omega$ (unless otherwise noted)

PARAMETER	FROM (INPUT)	TO (OUTPUT)	$C_L = 50\text{pF}$		$C_L = 30\text{pF}$		$C_L = 15\text{pF}$		UNIT
			MIN	MAX	MIN	MAX	MIN	MAX	
t_{PLH}	SCL1 or SDA1	SCL2 or SDA2	0	0.8	0	0.6	0	0.5	ns
t_{PHL}			0	1.2	0	1.1	0	1.0	

(1) Translating up: the low-voltage side driving toward the high-voltage side

Switching Characteristics AC Performance: Translating Up ⁽¹⁾, EN=2.5V

over recommended operating free-air temperature range, EN = 2.5 V, $V_{IH} = 2.3$ V, $V_{IL} = 0$, $V_T = 3.3$ V, $V_M = 0.75$ V, $R_L = 300\Omega$ (unless otherwise noted)

PARAMETER	FROM (INPUT)	TO (OUTPUT)	$C_L = 50\text{pF}$		$C_L = 30\text{pF}$		$C_L = 15\text{pF}$		UNIT
			MIN	MAX	MIN	MAX	MIN	MAX	
t_{PLH}	SCL1 or SDA1	SCL2 or SDA2	0	0.8	0	0.6	0	0.4	ns
t_{PHL}			0	1.2	0	1.2	0	1.0	

(1) Translating up: the low-voltage side driving toward the high-voltage side

Typical Characteristics

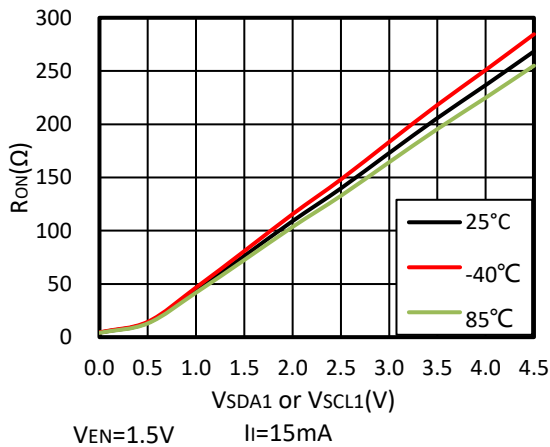

Figure 1. On-Resistance (R_{ON}) vs Input Voltage (V_{SDA1} or V_{SCL1})

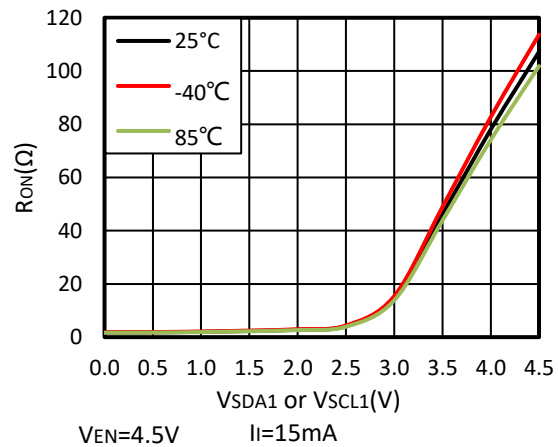

Figure 2. On-Resistance (R_{ON}) vs Input Voltage (V_{SDA1} or V_{SCL1})

Parameter Measurement Information

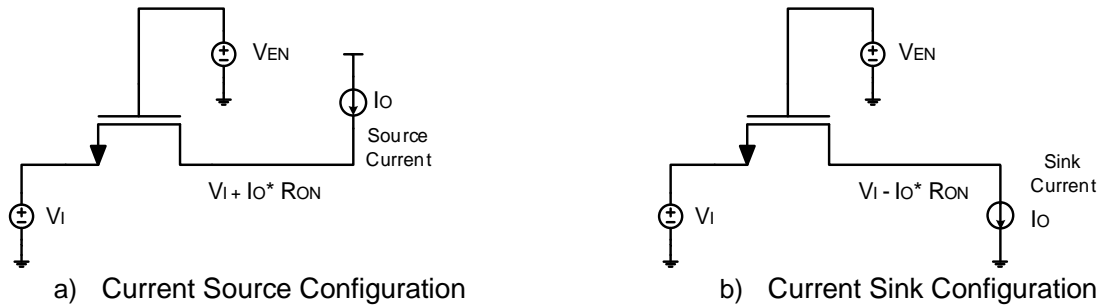
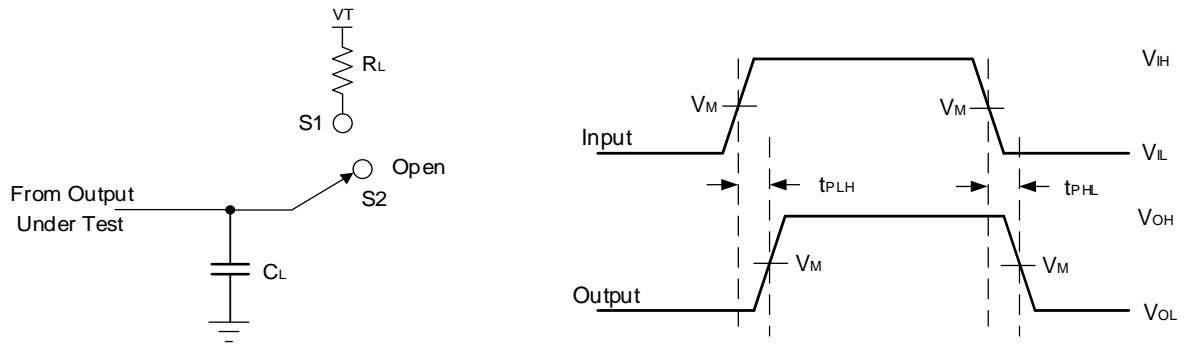

Figure 3. Current Source and Current Sink Configurations for R_{ON} Measurements



USAGE	SWITCH
Translating up	S1
Translating down	S2

- NOTES: A. C_L includes probe and jig capacitance
 B. All input pulses are supplied by generators having the following characteristics: $PRR \leq 10$ MHz, $Z_o = 50 \Omega$, $t_r \leq 2$ ns, $t_f \leq 2$ ns.
 C. The outputs are measured one at a time, with one transition per measurement.

Figure 4. Load Circuit for Outputs

Typical Application

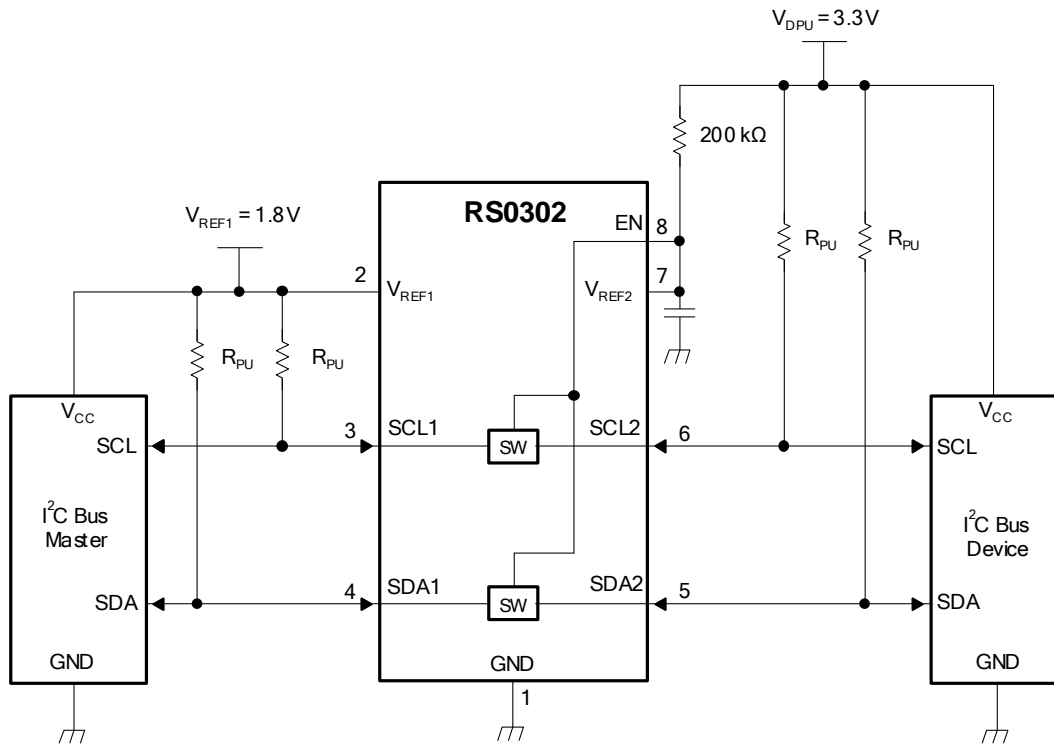
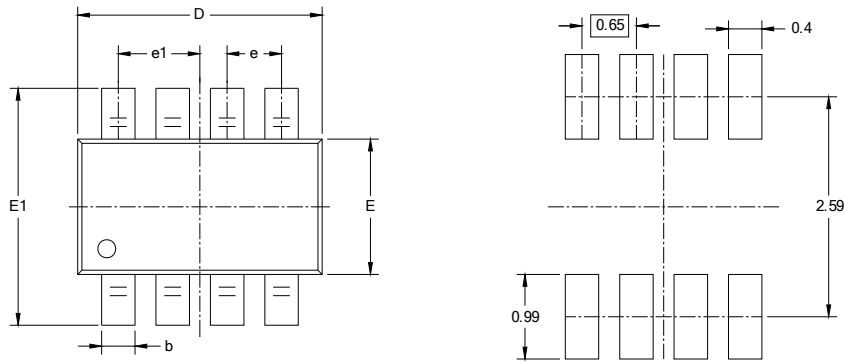

Figure 5. Typical Application Circuit (Switch Always Enabled)

PACKAGE OUTLINE DIMENSIONS

SOT23-8



RECOMMENDED LAND PATTERN (Unit: mm)

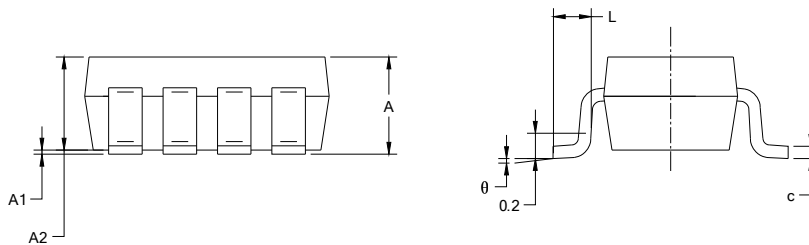

Symbol	Dimensions In Millimeters		Dimensions In Inches	
	Min	Max	Min	Max
A	1.050	1.250	0.041	0.049
A1	0.000	0.100	0.000	0.004
A2	1.050	1.150	0.041	0.045
b	0.300	0.500	0.012	0.020
c	0.100	0.200	0.004	0.008
D	2.820	3.020	0.111	0.119
E	1.500	1.700	0.059	0.067
E1	2.650	2.950	0.104	0.116
e	0.650(BSC)		0.026(BSC)	
e1	0.975(BSC)		0.038(BSC)	
L	0.300	0.600	0.012	0.024
θ	0°	8°	0°	8°

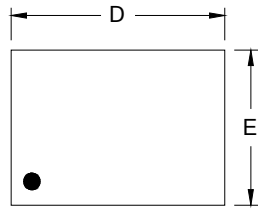
DFN1.4x1.0-8L

TOP VIEW

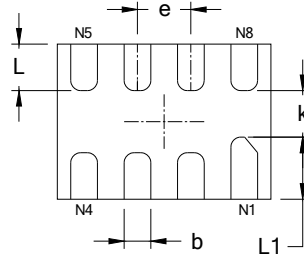

BOTTOM VIEW

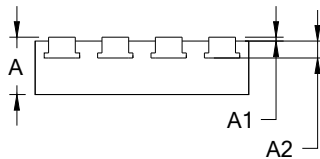

SIDE VIEW

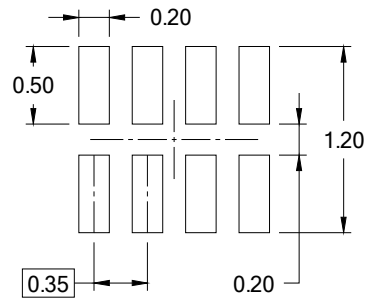

RECOMMENDED LAND PATTERN (Unit: mm)

Symbol	Dimensions In Millimeters		Dimensions In Inches	
	Min	Max	Min	Max
A	0.340	0.400	0.013	0.016
A1	0.000	0.050	0.000	0.002
A2	0.110 REF		0.004 REF	
D	1.350	1.450	0.053	0.057
E	0.950	1.050	0.037	0.041
k	0.200 MIN		0.008 MIN	
b	0.150	0.200	0.006	0.008
e	0.350 TYP		0.014 TYP	
L	0.250	0.350	0.010	0.014
L1	0.350	0.450	0.014	0.018

TAPE AND REEL INFORMATION

REEL DIMENSIONS

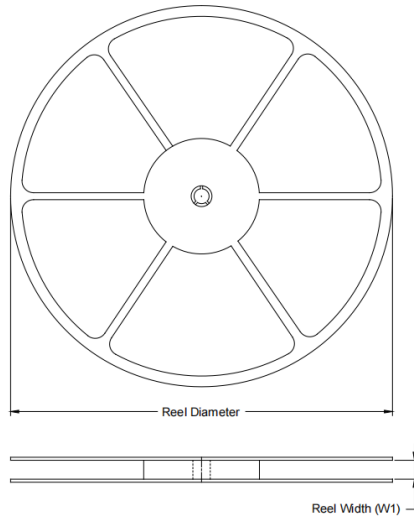

TAPE DIMENSION

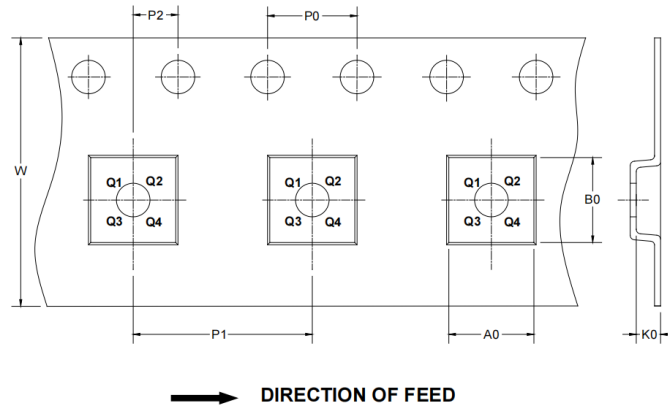

NOTE: The picture is only for reference. Please make the object as the standard.

KEY PARAMETER LIST OF TAPE AND REEL

Package Type	Reel Diameter	Reel Width (mm)	A0 (mm)	B0 (mm)	K0 (mm)	P0 (mm)	P1 (mm)	P2 (mm)	W (mm)	Pin1 Quadrant
SOT23-8	7"	9.5	3.17	3.23	1.37	4.0	4.0	2.0	8.0	Q3
DFN1.4x1.0-8L	7"	9.5	1.2	1.6	0.5	4.0	4.0	2.0	8.0	Q1

X-ON Electronics

Largest Supplier of Electrical and Electronic Components

Click to view similar products for [Translation - Voltage Levels](#) category:

Click to view products by [RUNIC](#) manufacturer:

Other Similar products are found below :

[NLSX4373DMR2G](#) [NLSX5012MUTAG](#) [NLSX0102FCT1G](#) [PCA9306FMUTAG](#) [MC100EPT622MNG](#) [NLSX3014MUTAG](#)
[NLSX5011MUTCG](#) [NLV5X4373MUTAG](#) [NB3U23CMNTAG](#) [NLSX3013BFCT1G](#) [NLV7WBD3125USG](#) [NLSX3012DMR2G](#)
[NLA9306MU3TCG](#) [PI4ULS3V304AZMAEX](#) [PI4ULS3V504AZMAEX](#) [74AVCH1T45FW3-7](#) [NLSX5011AMUTAG](#) [74AXP1T34GWH](#)
[ST2149BQTR](#) [MC100ELT21DR2G](#) [MC100LVELT22MNRG](#) [MC10ELT20DR2G](#) [MC10EPT20MNR4G](#) [MC14504BFELG](#)
[NLSV4T3234FCT1G](#) [NLSX3378BFCT1G](#) [UM3208QA](#) [UM3208H](#) [UM3304](#) [UM3304QT](#) [UM3202H](#) [UM3308](#) [RS0104YTQE12](#)
[RS0204YUTQH12](#) [AW39204QNR](#) [AW39114FOR](#) [RS0104YTQF14](#) [RS0204YTQF14](#) [UM3204QT](#) [UM3204QB](#) [UM3204QV](#)
[AIPTS0104TA14.TR](#) [AIPTB0104TA14.TR](#) [UM3304QS](#) [SN74LXC2T45DCUR](#) [TCA39306DTMR](#) [NTS0102TL-Q100H](#) [AW39112DNR](#)
[XP7660](#) [RS4T774XTSS16](#)