

RS151 8-Line To 1-Line Data Selectors/Multiplexers

1 FEATURES

- **Operating Voltage Range: 1.65V to 5.5V**
- **Low power consumption: 8 μ A MAX I_{cc}**
- **Inputs Accept Voltage to 5.5V**
- **Output Drive: \pm 6mA at V_{CC}=4.5V**
- **Operating Temperature Range: -40°C to +125°C**
- **PACKAGES: SOIC-16(SOP16) and TSSOP-16**

2 APPLICATIONS

- **Boolean-function generators**
- **Parallel-to-serial converters**
- **Data source selectors**

3 DESCRIPTIONS

The RS151, a data selector/multiplexer provides full binary decoding to select one of eight data sources.

The RS151 is consist of one enable input \bar{G} , three binary address inputs (A0, A1 and A2), eight data inputs (D0 to D7) and two outputs (Y and W). The strobe (\bar{G}) input must be at a low logic level to enable the inputs. A high level at the strobe terminal forces the standard output (Y) low and the inverted output (W) high.

The RS151 is available in Green SOIC-16(SOP16) and TSSOP-16 packages. It operates over an ambient temperature range of -40°C to +125°C.

Device Information ⁽¹⁾

PART NUMBER	PACKAGE	BODY SIZE (NOM)
RS151	SOIC-16(SOP16)	9.90mm \times 3.90mm
	TSSOP-16	5.00mm \times 4.40mm

(1) For all available packages, see the orderable addendum at the end of the data sheet.

Table of Contents

1 FEATURES	1
2 APPLICATIONS	1
3 DESCRIPTIONS	1
4 Revision History	3
5 PACKAGE/ORDERING INFORMATION ⁽¹⁾	4
6 PIN CONFIGURATIONS	5
7 SPECIFICATIONS	6
7.1 Absolute Maximum Ratings ⁽¹⁾	6
7.2 ESD Ratings	6
7.3 Recommended Operating Conditions.....	7
7.4 ELECTRICAL CHARACTERISTICS	7
7.5 Switching Characteristics.....	8
7.6 Operating Characteristics	8
8 Parameter Measurement Information	9
9 Detailed Description	10
9.1 Overview.....	10
9.2 Functional Block Diagram.....	10
9.3 Device Functional Modes.....	11
10 Power Supply Recommendations	12
11 Layout	12
11.1 Layout Guidelines	12
12 PACKAGE OUTLINE DIMENSIONS	13
13 TAPE AND REEL INFORMATION	15

4 Revision History

Note: Page numbers for previous revisions may differ from page numbers in the current version.

Version	Change Date	Change Item
A.1	2023/09/01	Initial version completed

5 PACKAGE/ORDERING INFORMATION ⁽¹⁾

PRODUCT	ORDERING NUMBER	TEMPERATURE RANGE	PACKAGE LEAD	PACKAGE MARKING ⁽²⁾	MSL ⁽³⁾	PACKAGE OPTION
RS151	RS151XS16	-40°C ~+125°C	SOIC-16(SOP16)	RS151	MSL3	Tape and Reel,4000
	RS151XTSS16	-40°C ~+125°C	TSSOP-16	RS151	MSL3	Tape and Reel,4000

NOTE:

- (1) This information is the most current data available for the designated devices. This data is subject to change without notice and revision of this document. For browser-based versions of this data sheet, refer to the right-hand navigation.
- (2) There may be additional marking, which relates to the lot trace code information (data code and vendor code), the logo or the environmental category on the device.
- (3) MSL, The Moisture Sensitivity Level rating according to the JEDEC industry standard classifications.

6 PIN CONFIGURATIONS

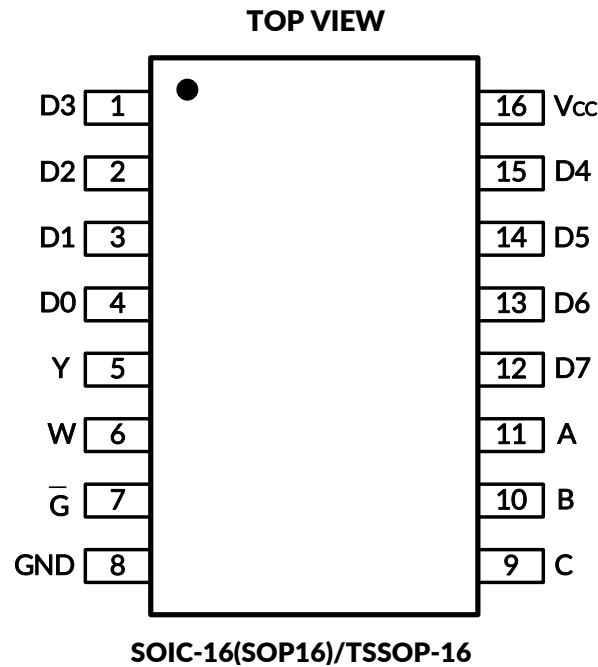

PIN DESCRIPTION

PIN	NAME	I/O TYPE ⁽¹⁾	FUNCTION
SOIC-16(SOP16)/TSSOP-16			
1	D3	I	Data input
2	D2	I	Data input
3	D1	I	Data input
4	D0	I	Data input
5	Y	O	Output
6	W	O	Output
7	\bar{G}	I	Enable input (active LOW)
8	GND	-	Ground
9	C	I	Address input
10	B	I	Address input
11	A	I	Address input
12	D7	I	Data input
13	D6	I	Data input
14	D5	I	Data input
15	D4	I	Data input
16	Vcc	-	Power Supply

(1) I=Input, O=Output.

7 SPECIFICATIONS

7.1 Absolute Maximum Ratings ⁽¹⁾

over operating free-air temperature range (unless otherwise noted) ^{(1) (2)}

		MIN	MAX	UNIT
V _{CC}	Supply voltage range	-0.5	7	V
I _{IK}	Input clamp current ⁽²⁾	V _I < 0 or V _I > V _{CC}		±20 mA
I _{OK}	Output clamp current ⁽²⁾	V _O < 0 or V _O > V _{CC}		±20 mA
I _O	Continuous output current	V _O = 0 to V _{CC}		±35 mA
	Continuous current through V _{CC} or GND		±70	mA
θ _{JA}	Package thermal impedance ⁽³⁾	SOIC-16(SOP16)		150 °C/W
		TSSOP-16		45
T _J	Junction temperature ⁽⁴⁾		150	°C
T _{stg}	Storage temperature	-65	150	°C

(1) Stresses beyond those listed under Absolute Maximum Ratings may cause permanent damage to the device. These are stress ratings only, and functional operation of the device at these or any other conditions beyond those indicated under Recommended Operating Conditions is not implied. Exposure to absolute-maximum-rated conditions for extended periods may affect device reliability.

(2) The input and output negative-voltage ratings may be exceeded if the input and output current ratings are observed.

(3) The package thermal impedance is calculated in accordance with JESD-51.

(4) The maximum power dissipation is a function of T_{J(MAX)}, R_{θJA}, and T_A. The maximum allowable power dissipation at any ambient temperature is P_D = (T_{J(MAX)} - T_A) / R_{θJA}. All numbers apply for packages soldered directly onto a PCB.

7.2 ESD Ratings

The following ESD information is provided for handling of ESD-sensitive devices in an ESD protected area only.

		VALUE	UNIT
V _(ESD) Electrostatic discharge	Human-body model (HBM), MIL-STD-883K METHOD 3015.9	±2000	V
	Charged-device model (CDM), ANSI/ESDA/JEDEC JS-002-2018	±1000	V
	Machine Model (MM), JESD22-A115C (2010)	±200	V



ESD SENSITIVITY CAUTION

ESD damage can range from subtle performance degradation to complete device failure. Precision integrated circuits may be more susceptible to damage because very small parametric changes could cause the device not to meet its published specifications.

7.3 Recommended Operating Conditions

PARAMETER	SYMBOL	TEST CONDITIONS	MIN	MAX	UNIT
Supply voltage	V_{CC}		1.65	5.5	V
High-level input voltage	V_{IH}	$V_{CC}=2V$	1.5		V
		$V_{CC}=4.5V$	3.15		
		$V_{CC}=5.5V$	3.85		
Low-level input voltage	V_{IL}	$V_{CC}=2V$		0.5	V
		$V_{CC}=4.5V$		1.35	
		$V_{CC}=5.5V$		1.65	
Input voltage	V_I		0	V_{CC}	V
Output voltage	V_O		0	V_{CC}	V
Input transition rise and fall time	t_t	$V_{CC}=2V$		1000	ns
		$V_{CC}=4.5V$		500	
		$V_{CC}=5.5V$		400	
Operating temperature	T_A		-40	125	°C

(1) All unused inputs of the device must be held at V_{CC} or GND to ensure proper device operation.

7.4 ELECTRICAL CHARACTERISTICS

over recommended operating free-air temperature range (TYP values are at $T_A = +25^{\circ}C$, unless otherwise noted.)⁽¹⁾

PARAMETER	TEST CONDITIONS	V_{CC}	TEMP	MIN ⁽²⁾	TYP ⁽³⁾	MAX ⁽²⁾	UNIT
V_{OH}	$I_{OH} = -20\mu A$	1.65V to 5.5V	Full	$V_{CC}-0.1$			V
	$I_{OH} = -6mA$	4.5V		4.0			
	$I_{OH} = -7.8mA$	5.5V		5.0			
V_{OL}	$I_{OL} = 20\mu A$	1.65V to 5.5V	Full			0.1	V
	$I_{OL} = 6mA$	4.5V				0.35	
	$I_{OL} = 7.8mA$	5.5V				0.45	
I_I	$V_I = V_{CC}$ or GND	0V to 5.5V	+25°C		± 0.1	± 1	uA
			Full			± 2	
I_{CC}	$V_I = V_{CC}$ or GND, $I_O = 0$	1.65V to 5.5V	+25°C		± 0.1	1	uA
			Full			8	
C_i		1.65V to 5.5V		3		12	pF

(1) All unused inputs of the device must be held at V_{CC} or GND to ensure proper device operation.

(2) Limits are 100% production tested at 25°C. Limits over the operating temperature range are ensured through correlations using statistical quality control (SQC) method.

(3) Typical values represent the most likely parametric norm as determined at the time of characterization. Actual typical values may vary over time and will also depend on the application and configuration.

7.5 Switching Characteristics

over recommended operating free-air temperature range, $C_L = 50$ pF (unless otherwise noted) (see Parameter Measurement Information)⁽¹⁾

PARAMETER	FROM (INPUT)	TO (OUTPUT)	V _{CC}	MIN ⁽²⁾	TYP ⁽³⁾	MAX ⁽²⁾	UNIT
t _{pd}	A, B, or C	Y or W	2V		27		ns
			4.5V		10		
			5.5V		9		
	Any D	Y or W	2V		26		ns
			4.5V		10		
			5.5V		9		
	\bar{G}	Y or W	2V		25		ns
			4.5V		10		
			5.5V		9		
t _t		Y or W	2V		15		ns
			4.5V		6		
			5.5V		6		

(1) All unused inputs of the device must be held at V_{CC} or GND to ensure proper device operation.

(2) This parameter is ensured by design and/or characterization and is not tested in production.

(3) Typical values represent the most likely parametric norm as determined at the time of characterization. Actual typical values may vary over time and will also depend on the application and configuration.

Switching Characteristics

over recommended operating free-air temperature range, $C_L = 150$ pF (unless otherwise noted) (see Parameter Measurement Information)⁽¹⁾

PARAMETER	FROM (INPUT)	TO (OUTPUT)	V _{CC}	MIN ⁽²⁾	TYP ⁽³⁾	MAX ⁽²⁾	UNIT
t _{pd}	A, B, or C	Y or W	2V		35		ns
			4.5V		13		
			5.5V		12		
	Any D	Y or W	2V		34		ns
			4.5V		13		
			5.5V		12		
	\bar{G}	Y or W	2V		32		ns
			4.5V		13		
			5.5V		12		
t _t		Y or W	2V		28		ns
			4.5V		12		
			5.5V		10		

(1) All unused inputs of the device must be held at V_{CC} or GND to ensure proper device operation.

(2) This parameter is ensured by design and/or characterization and is not tested in production.

(3) Typical values represent the most likely parametric norm as determined at the time of characterization. Actual typical values may vary over time and will also depend on the application and configuration.

7.6 Operating Characteristics

over recommended operating free-air temperature range, (TYP values are at T_A = +25°C, unless otherwise noted)

PARAMETER	TEST CONDITIONS	TYP	UNIT
C _{PD}	Power dissipation capacitance	No load	20 pF

8 Parameter Measurement Information

Phase relationships between waveforms were chosen arbitrarily. All input pulses are supplied by generators having the following characteristics: $PRR \leq 1 \text{ MHz}$, $Z_O = 50 \Omega$, $t_t < 6 \text{ ns}$.

For clock inputs, f_{\max} is measured when the input duty cycle is 50%.

The outputs are measured one at a time with one input transition per measurement.

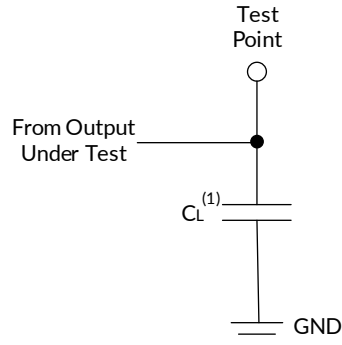

(1) C_L includes probe and test-fixture capacitance.

Figure 1. Load Circuit for Push-Pull Outputs

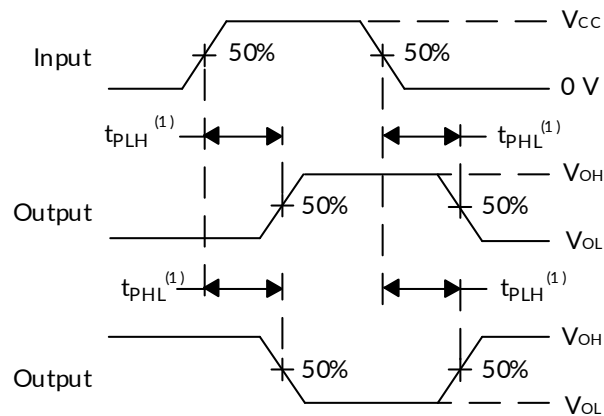

(1) The greater between t_{PLH} and t_{PHL} is the same as t_{pd} .

Figure 2. Voltage Waveforms, Propagation Delays for Standard CMOS Inputs

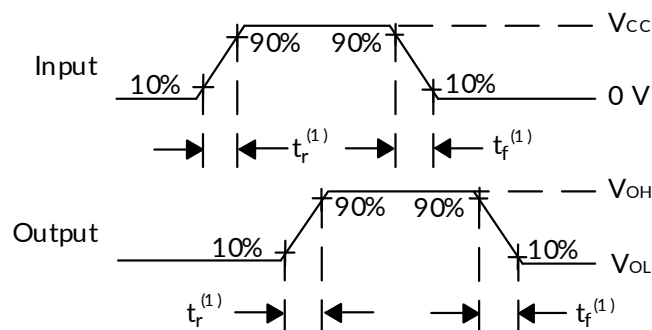

(1) The greater between t_r and t_f is the same as t_t .

Figure 3. Voltage Waveforms, Input and Output Transition Times for Standard CMOS Inputs

9 Detailed Description

9.1 Overview

This data selector/multiplexer provides full binary decoding to select one of eight data sources. The strobe (\bar{G}) input must be at a low logic level to enable the inputs. A high level at the strobe terminal forces the standard output (Y) low and the inverted output (W) high.

9.2 Functional Block Diagram

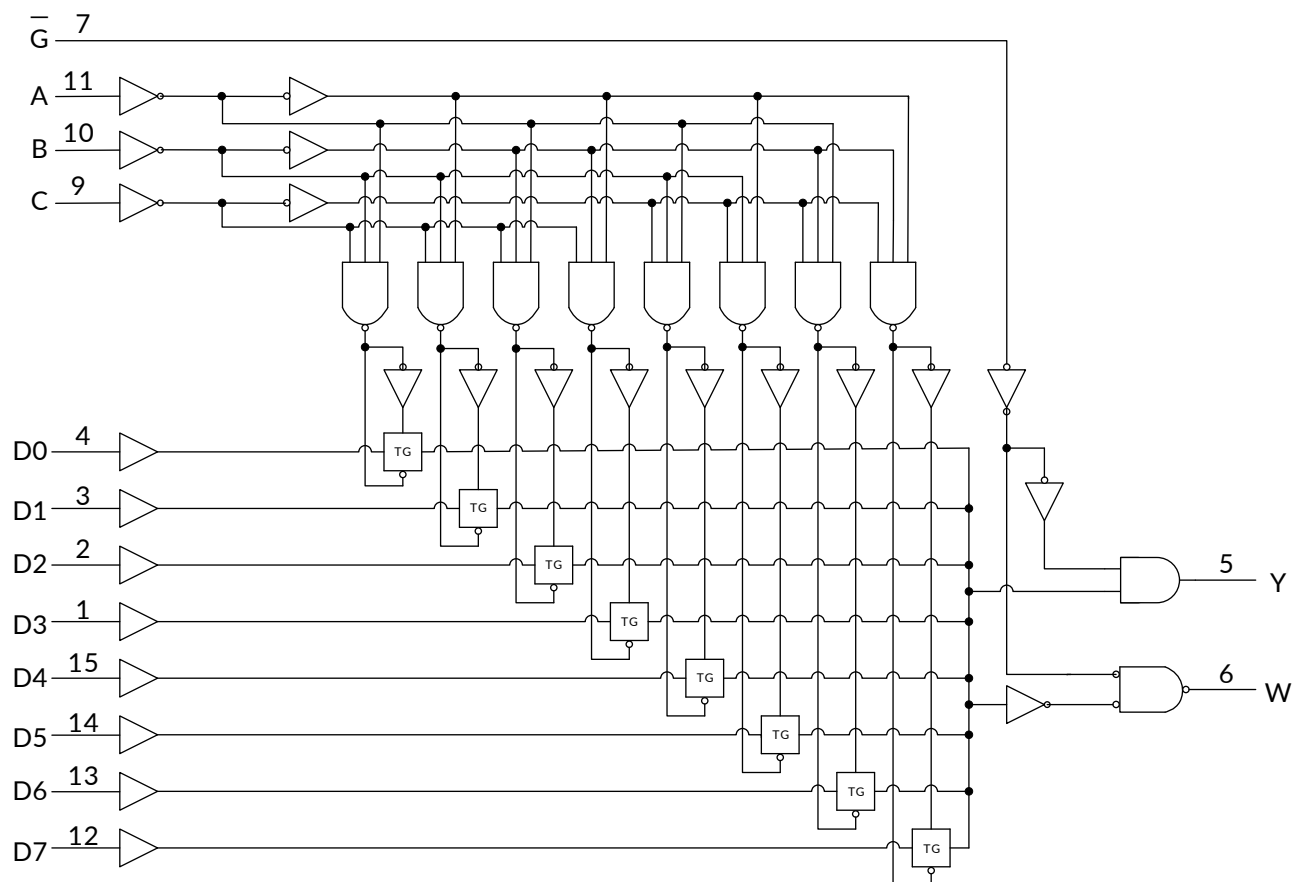

9.3 Device Functional Modes

Device Function Table

ENABLE INPUT	SELECT INPUTS			OUTPUTS	
\bar{G}	C	B	A	Y	W
H	X	X	X	L	H
L	L	L	L	D0	$\bar{D0}$
L	L	L	H	D1	$\bar{D1}$
L	L	H	L	D2	$\bar{D2}$
L	L	H	H	D3	$\bar{D3}$
L	H	L	L	D4	$\bar{D4}$
L	H	L	H	D5	$\bar{D5}$
L	H	H	L	D6	$\bar{D6}$
L	H	H	H	D7	$\bar{D7}$

H: High Voltage Level

L: Low Voltage Level

D0, D1 . . . D7 = the level of the respective D input.

10 Power Supply Recommendations

The power supply can be any voltage between the minimum and maximum supply voltage rating located in the Recommended Operating Conditions. Each V_{CC} terminal should have a good bypass capacitor to prevent power disturbance. A $0.1\mu\text{F}$ capacitor is recommended for this device. It is acceptable to parallel multiple bypass caps to reject different frequencies of noise. The $0.1\mu\text{F}$ and $1\mu\text{F}$ capacitors are commonly used in parallel. The bypass capacitor should be installed as close to the power terminal as possible for best results.

11 Layout

11.1 Layout Guidelines

When using multiple-input and multiple-channel logic devices inputs must not ever be left floating. In many cases, functions or parts of functions of digital logic devices are unused; for example, when only two inputs of a triple-input AND gate are used or only 3 of the 4 buffer gates are used. Such unused input pins must not be left unconnected because the undefined voltages at the outside connections result in undefined operational states. All unused inputs of digital logic devices must be connected to a logic high or logic low voltage, as defined by the input voltage specifications, to prevent them from floating. The logic level that must be applied to any particular unused input depends on the function of the device. Generally, the inputs are tied to GND or V_{CC} , whichever makes more sense for the logic function or is more convenient.

12 PACKAGE OUTLINE DIMENSIONS

SOIC-16(SOP16)⁽³⁾

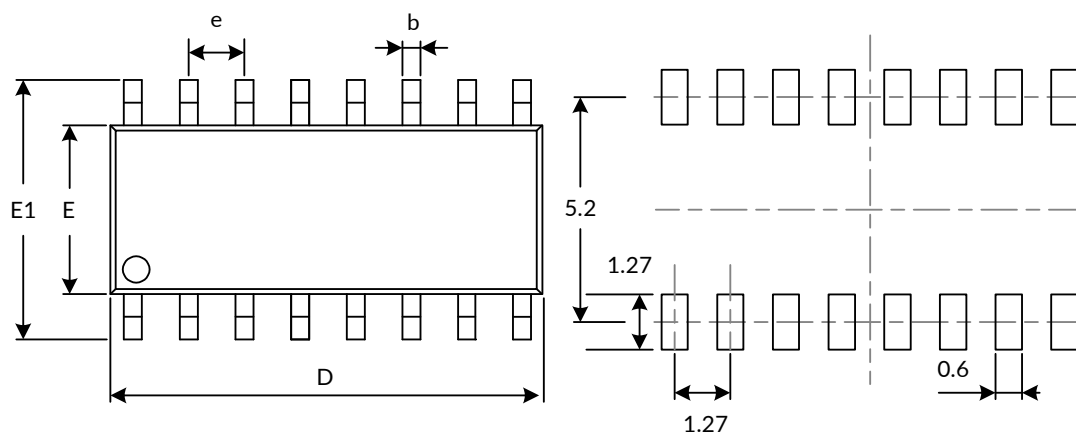

RECOMMENDED LAND PATTERN (Unit: mm)

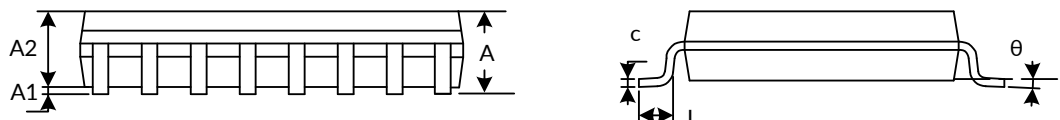

Symbol	Dimensions In Millimeters		Dimensions In Inches	
	Min	Max	Min	Max
A ⁽¹⁾		1.750		0.069
A1	0.100	0.225	0.004	0.009
A2	1.300	1.500	0.051	0.059
b	0.390	0.470	0.015	0.019
c	0.200	0.240	0.008	0.009
D ⁽¹⁾	9.800	10.000	0.386	0.394
E ⁽¹⁾	3.800	4.000	0.150	0.157
E1	5.800	6.200	0.228	0.244
e	1.270(BSC) ⁽²⁾		0.050(BSC) ⁽²⁾	
L	0.500	0.800	0.020	0.031
θ	0°	8°	0°	8°

NOTE:

1. Plastic or metal protrusions of 0.15mm maximum per side are not included.
2. BSC (Basic Spacing between Centers), "Basic" spacing is nominal.
3. This drawing is subject to change without notice.

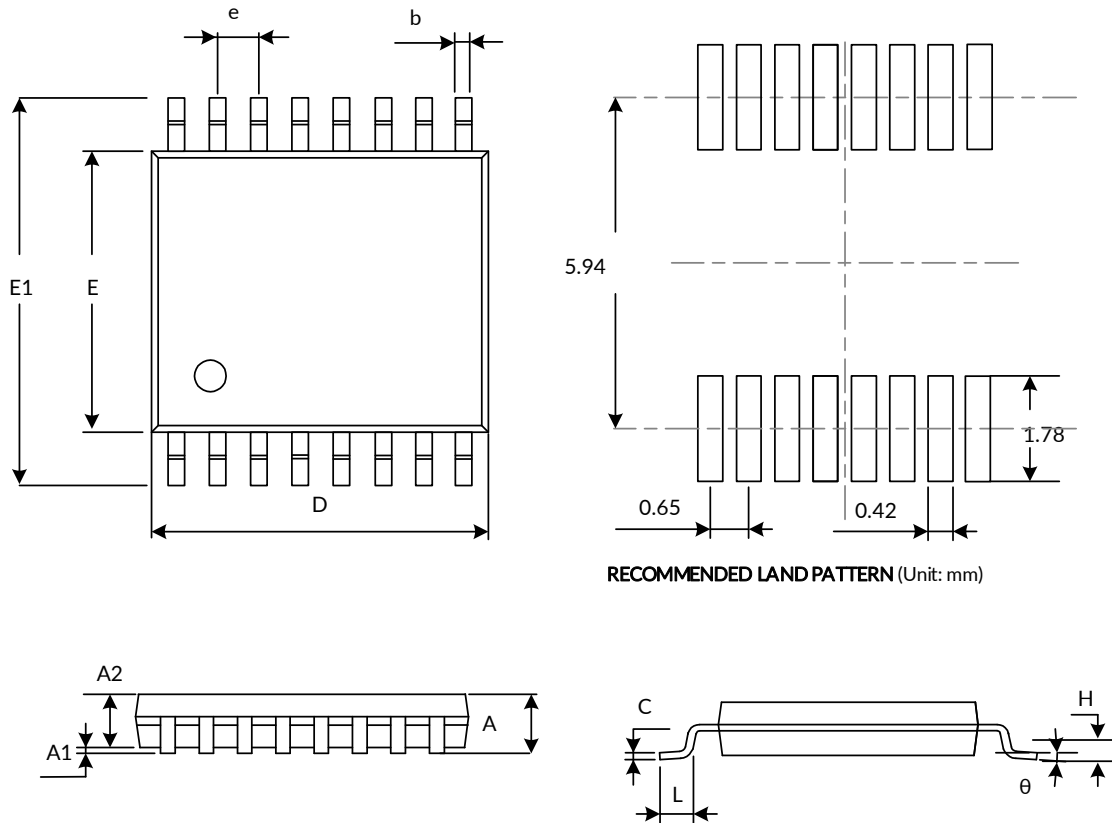
TSSOP-16⁽³⁾

RECOMMENDED LAND PATTERN (Unit: mm)

Symbol	Dimensions In Millimeters		Dimensions In Inches	
	Min	Max	Min	Max
A ⁽¹⁾		1.200		0.047
A1	0.050	0.150	0.002	0.006
A2	0.800	1.050	0.031	0.041
b	0.190	0.300	0.007	0.012
c	0.090	0.200	0.004	0.008
D ⁽¹⁾	4.860	5.100	0.191	0.201
E ⁽¹⁾	4.300	4.500	0.169	0.177
E1	6.200	6.600	0.244	0.260
e	0.650(BSC) ⁽²⁾		0.026(BSC) ⁽²⁾	
L	0.500	0.700	0.02	0.028
H	0.25TYP		0.01TYP	
θ	1°	7°	1°	7°

NOTE:

1. Plastic or metal protrusions of 0.15mm maximum per side are not included.
2. BSC (Basic Spacing between Centers), "Basic" spacing is nominal.
3. This drawing is subject to change without notice.

13 TAPE AND REEL INFORMATION

REEL DIMENSIONS

TAPE DIMENSION

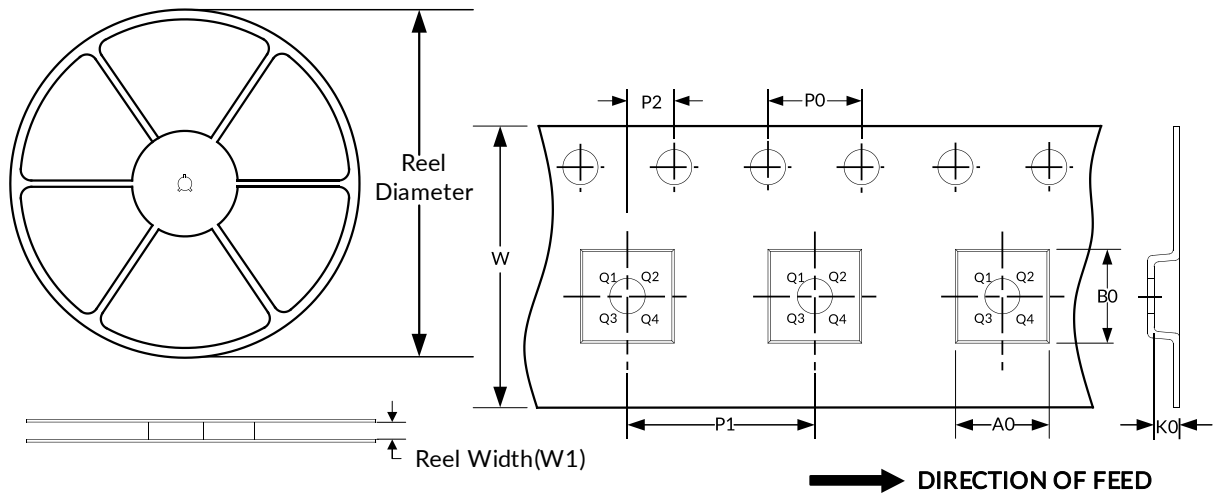

NOTE: The picture is only for reference. Please make the object as the standard.

KEY PARAMETER LIST OF TAPE AND REEL

Package Type	Reel Diameter	Reel Width(mm)	A0 (mm)	B0 (mm)	K0 (mm)	P0 (mm)	P1 (mm)	P2 (mm)	W (mm)	Pin1 Quadrant
SOIC-16(SOP16)	13"	16.4	6.50	10.30	2.10	4.0	8.0	2.0	16.0	Q1
TSSOP-16	13"	12.4	6.90	5.60	1.20	4.0	8.0	2.0	12.0	Q1

NOTE:

1. All dimensions are nominal.
2. Plastic or metal protrusions of 0.15mm maximum per side are not included.

IMPORTANT NOTICE AND DISCLAIMER

Jiangsu Runic Technology Co., Ltd. will accurately and reliably provide technical and reliability data (including data sheets), design resources (including reference designs), application or other design advice, WEB tools, safety information and other resources, without warranty of any defect, and will not make any express or implied warranty, including but not limited to the warranty of merchantability Implied warranty that it is suitable for a specific purpose or does not infringe the intellectual property rights of any third party.

These resources are intended for skilled developers designing with Runic products You will be solely responsible for: (1) Selecting the appropriate products for your application; (2) Designing, validating and testing your application; (3) Ensuring your application meets applicable standards and any other safety, security or other requirements; (4) Runic and the Runic logo are registered trademarks of Runic Incorporated. All trademarks are the property of their respective owners; (5) For change details, review the revision history included in any revised document. The resources are subject to change without notice. Our company will not be liable for the use of this product and the infringement of patents or third-party intellectual property rights due to its use.

X-ON Electronics

Largest Supplier of Electrical and Electronic Components

Click to view similar products for [Analogue Switch ICs category](#):

Click to view products by [RUNIC manufacturer](#):

Other Similar products are found below :

[FSA3051TMX](#) [NLAS5223BLMNR2G](#) [NLX2G66DMUTCG](#) [425541DB](#) [DG403DY](#) [099044FB](#) [MAX4762ETB+](#) [NLAS3799BMNR2G](#)
[NLAS5123MNR2G](#) [ISL84684IR](#) [PI5A4157CEX](#) [PI5A4599BCEX](#) [NLAS4717EPFCT1G](#) [PI5A3167CCEX](#) [SLAS3158MNR2G](#) [PI5A392AQE](#)
[DG333ALDW-T1-E3](#) [ISL43113IB](#) [ISL43140IB](#) [ISL43140IBZ-T](#) [ISL43143IR](#) [ISL43L120IR](#) [ISL43L121IR](#) [ISL43L122IR](#) [ISL43L220IR](#)
[ISL43L410IR](#) [ISL43L420IR](#) [ISL43L710IR](#) [ISL43L711IR](#) [ISL43L712IR](#) [ISL84053IA](#) [ISL84514IB](#) [ISL84516IB](#) [ISL84684IUZ-T](#)
[LNLASB3157DFT2G](#) [NLAS324US](#) [NLASTV4599DFT2G](#) [TPW4053-SR](#) [WAS4642Q-24/TR](#) [ADG842YKSZ-REEL7](#) [WAS4766C-9/TR](#)
[WAS7227Q-10/TR](#) [WAS4646C-36/TR](#) [WAS4735Q-16/TR](#) [BL1532TQFN](#) [RS2233YS16](#) [CH483M](#) [TMUX646ZECR](#) [TMUX1248DCKR](#)
[TMUX7236RUMR](#)