

RS1G373 Single D-Type Latch With 3-State Output

1 FEATURES

- **Operating Voltage Range: 1.65V to 5.5V**
- **Low Power Consumption: 10µA (Max)**
- **Operating Temperature Range: -40°C to +125°C**
- **Inputs Accept Voltage to 5.5V**
- **High Output Drive: ±24mA at V_{CC}=3.0V**
- **I_{off} Supports Live Insertion, Partial-Power Down Mode, and Back-Drive Protection**
- **Micro SIZE PACKAGES: SOT23-6, SOT363(SC70-6)**

2 APPLICATIONS

- Servers
- Printers
- Telecom and Grid Infrastructure
- Electronic Point of Sale
- Memory Addressing
- Buffer Registers

3 DESCRIPTIONS

The RS1G373 device is a single D-type latch is designed for 1.65V to 5.5V V_{CC} operation.

This device is particularly suitable for implementing buffer registers, I/O ports, bidirectional bus drivers and working registers. While the latch-enable (LE) input is high, the Q outputs follow the data (D) inputs. When LE is taken low, the Q outputs are latched at the logic levels set up at the D inputs.

\overline{OE} does not affect the internal operations of the latch. Old data can be retained or new data can be entered while the outputs are in the high-impedance state.

The RS1G373 is fully specified for partial-power-down applications using I_{off}. The I_{off} circuitry disables the outputs, preventing damaging current backflow through the device when it is powered down.

This device available in Green SOT23-6 and SOT363(SC70-6) packages. It operates over an ambient temperature range of -40°C to +125°C.

Device Information ⁽¹⁾

PART NUMBER	PACKAGE	BODY SIZE (NOM)
RS1G373	SOT23-6(6)	2.92mm×1.60mm
	SOT363 (SC70-6)(6)	2.10mm×1.25mm

(1) For all available packages, see the orderable addendum at the end of the data sheet.

Table of Contents

1 FEATURES	1
2 APPLICATIONS	1
3 DESCRIPTIONS	1
4 Revision History	3
5 PACKAGE/ORDERING INFORMATION ⁽¹⁾	4
6 PIN CONFIGURATIONS	5
6.1 PIN DESCRIPTION.....	5
6.2 FUNCTION TABLE	5
7 SPECIFICATIONS	6
7.1 Absolute Maximum Ratings ⁽¹⁾	6
7.2 ESD Ratings	6
8 ELECTRICAL CHARACTERISTICS	7
8.1 Recommended Operating Conditions.....	7
8.2 DC Characteristics	8
8.3 Timing Requirements.....	9
8.4 Switching Characteristics.....	9
8.5 Operating Characteristics	9
9 Parameter Measurement Information	10
10 Detailed Description	11
10.1 Overview	11
10.2 Functional Block Diagram	11
10.3 Feature Description.....	11
10.3.1 Partial Power Down (I_{off}).....	11
10.3.2 Over-Voltage Tolerant Inputs.....	11
11 Application and Implementation	12
11.1 Application Information.....	12
11.2 Typical Application	12
11.2.1 Design Requirements	12
11.2.2 Detailed Design Procedure	12
12 Power Supply Recommendations	12
13 Layout	13
13.1 Layout Guidelines	13
13.2 Layout Example.....	13
14 PACKAGE OUTLINE DIMENSIONS	14
15 TAPE AND REEL INFORMATION	16

4 Revision History

Note: Page numbers for previous revisions may differ from page numbers in the current version.

Version	Change Date	Change Item
A.1	2023/09/13	Initial version completed

5 PACKAGE/ORDERING INFORMATION ⁽¹⁾

PRODUCT	ORDERING NUMBER	TEMPERATURE RANGE	PACKAGE LEAD	PACKAGE MARKING ⁽²⁾	MSL ⁽³⁾	PACKAGE OPTION
RS1G373	RS1G373XH6	-40°C ~+125°C	SOT23-6	1G373	MSL3	Tape and Reel,3000
	RS1G373XC6	-40°C ~+125°C	SC70-6(SOT363)	1G373	MSL3	Tape and Reel,3000

NOTE:

- (1) This information is the most current data available for the designated devices. This data is subject to change without notice and revision of this document. For browser-based versions of this data sheet, refer to the right-hand navigation.
- (2) There may be additional marking, which relates to the lot trace code information (data code and vendor code), the logo or the environmental category on the device.
- (3) MSL, The Moisture Sensitivity Level rating according to the JEDEC industry standard classifications.

6 PIN CONFIGURATIONS

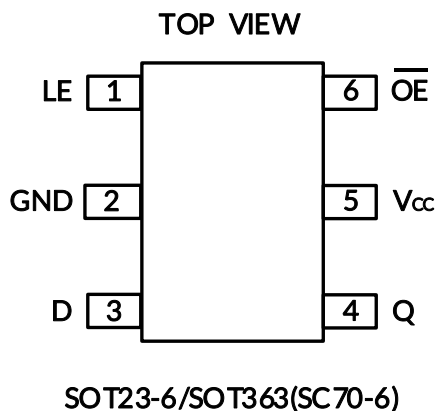

6.1 PIN DESCRIPTION

PIN	NAME	I/O TYPE ⁽¹⁾	FUNCTION
SOT23-6/SOT363(SC70-6)			
1	LE	I	Latch Enable; output follows D input when high
2	GND	-	Ground
3	D	I	D latch input
4	Q	O	Q latch output
5	V _{cc}	-	Supply Voltage
6	\overline{OE}	I	Active low output enable; Hi-Z output when high

(1) I=input, O=output, P=power.

6.2 FUNCTION TABLE

INPUTS			OUTPUT
\overline{OE}	LE	D	Q
L	H	L	L
L	H	H	H
L	L	X	Q ₀
H	X	X	Hi-Z

(1) H=High Voltage Level
L=Low Voltage Level
X=Don't Care

7 SPECIFICATIONS

7.1 Absolute Maximum Ratings ⁽¹⁾

over operating free-air temperature range (unless otherwise noted) ^{(1) (2)}

		MIN	MAX	UNIT
V _{CC}	Supply voltage range	-0.5	6.5	V
V _I	Input voltage range ⁽²⁾	-0.5	6.5	V
V _O	Voltage range applied to any output in the high-impedance or power-off state ⁽²⁾	-0.5	6.5	V
V _O	Voltage range applied to any output in the high or low state ^{(2) (3)}	-0.5	V _{CC} +0.5	V
I _{IK}	Input clamp current	V _I <0	-50	mA
I _{OK}	Output clamp current	V _O <0	-50	mA
I _O	Continuous output current		±50	mA
	Continuous current through V _{CC} or GND		±100	mA
θ _{JA}	Package thermal impedance ⁽⁴⁾	SOT23-6	230	°C/W
		SOT363/(SC70-6)	265	
T _J	Junction temperature ⁽⁵⁾	-65	150	°C
T _{stg}	Storage temperature	-65	150	°C

- (1) Stresses beyond those listed under Absolute Maximum Ratings may cause permanent damage to the device. These are stress ratings only, and functional operation of the device at these or any other conditions beyond those indicated under Recommended Operating Conditions is not implied. Exposure to absolute-maximum-rated conditions for extended periods may affect device reliability.
- (2) The input and output negative-voltage ratings may be exceeded if the input and output current ratings are observed.
- (3) The value of V_{CC} is provided in the Recommended Operating Conditions table.
- (4) The package thermal impedance is calculated in accordance with JESD-51.
- (5) The maximum power dissipation is a function of T_{J(MAX)}, R_{θJA}, and T_A. The maximum allowable power dissipation at any ambient temperature is P_D = (T_{J(MAX)} - T_A) / R_{θJA}. All numbers apply for packages soldered directly onto a PCB.

7.2 ESD Ratings

The following ESD information is provided for handling of ESD-sensitive devices in an ESD protected area only.

		VALUE	UNIT
V _(ESD)	Electrostatic discharge	Human-body model (HBM), MIL-STD-883K METHOD 3015.9	±2000
		Charged-device model (CDM), ANSI/ESDA/JEDEC JS-002-2018	±1000
		Machine Model (MM), JESD22-A115C (2010)	±200



ESD SENSITIVITY CAUTION

ESD damage can range from subtle performance degradation to complete device failure. Precision integrated circuits may be more susceptible to damage because very small parametric changes could cause the device not to meet its published specifications.

8 ELECTRICAL CHARACTERISTICS

over recommended operating free-air temperature range (TYP values are at $T_A = +25^\circ\text{C}$, Full= -40°C to 125°C , unless otherwise noted.) ⁽¹⁾

8.1 Recommended Operating Conditions

PARAMETER	SYMBOL	TEST CONDITIONS	MIN	MAX	UNIT
Supply voltage	V_{CC}	Operating	1.65	5.5	V
High-level input voltage	V_{IH}	$V_{CC}=1.65\text{V to }1.95\text{V}$	$0.75 \times V_{CC}$		V
		$V_{CC}=2.3\text{V to }2.7\text{V}$	1.7		
		$V_{CC}=3\text{V to }3.6\text{V}$	2		
		$V_{CC}=4.5\text{V to }5.5\text{V}$	$0.7 \times V_{CC}$		
Low-level input voltage	V_{IL}	$V_{CC}=1.65\text{V to }1.95\text{V}$		$0.25 \times V_{CC}$	V
		$V_{CC}=2.3\text{V to }2.7\text{V}$		0.7	
		$V_{CC}=3\text{V to }3.6\text{V}$		0.8	
		$V_{CC}=4.5\text{V to }5.5\text{V}$		$0.3 \times V_{CC}$	
Input voltage	V_I		0	5.5	V
Output voltage	V_O		0	V_{CC}	V
High-level output current	I_{OH}	$V_{CC}=1.65\text{V}$		-4	mA
		$V_{CC}=2.3\text{V}$		-8	
		$V_{CC}=3\text{V}$		-16	
		$V_{CC}=4.5\text{V}$		-32	
Low-level output current	I_{OL}	$V_{CC}=1.65\text{V}$		4	mA
		$V_{CC}=2.3\text{V}$		8	
		$V_{CC}=3\text{V}$		16	
		$V_{CC}=4.5\text{V}$		32	
Input transition rise or fall	$\Delta t / \Delta v$	$V_{CC}=1.8\text{V} \pm 0.15\text{V}, 2.5\text{V} \pm 0.2\text{V}$		20	ns/V
		$V_{CC}=3.3\text{V} \pm 0.3\text{V}$		10	
		$V_{CC}=5\text{V} \pm 0.5\text{V}$		5	
Operating temperature	T_A		-40	125	$^\circ\text{C}$

(1) All unused inputs of the device must be held at V_{CC} or GND to ensure proper device operation.

8.2 DC Characteristics

PARAMETER		TEST CONDITIONS	V _{CC}	TEMP	MIN ⁽²⁾	TYP ⁽³⁾	MAX ⁽²⁾	UNIT
V _{OH}		I _{OH} = -100μA	1.65V to 5.5V	Full	V _{CC} -0.1			V
		I _{OH} = -4mA	1.65V		1.2			
		I _{OH} = -8mA	2.3V		1.9			
		I _{OH} = -16mA	3V		2.4			
		I _{OH} = -24mA			2.3			
		I _{OH} = -32mA	4.5V		3.8			
V _{OL}		I _{OL} = 100μA	1.65V to 5.5V	Full			0.1	V
		I _{OL} = 4mA	1.65V				0.45	
		I _{OL} = 8mA	2.3V				0.3	
		I _{OL} = 16mA	3V				0.4	
		I _{OL} = 24mA					0.55	
		I _{OL} = 32mA	4.5V				0.55	
I _i	Data or control inputs	V _I =5.5V or GND	0V to 5.5V	+25°C		±0.1	±1	μA
				Full			±5	
I _{oz}		V _O =0V to 5.5V	3.6V	+25°C		±0.1	±1	μA
				Full			±5	
I _{off}		V _I or V _O =5.5V	0	+25°C		±0.1	±1	μA
				Full			±10	
I _{CC}		V _I =5.5V or GND, I _O =0	1.65V to 5.5V	+25°C		0.1	1	μA
				Full			10	
ΔI _{CC}		One input at V _{CC} -0.6V, Other inputs at V _{CC} or GND	3V to 5.5V	Full			500	μA
C _i (Input Capacitance)		V _I = V _{CC} or GND	3.3V	+25°C		4		pF
C _o (Output Capacitance)		V _O = V _{CC} or GND	3.3V	+25°C		6		pF

(1) All unused inputs of the device must be held at V_{CC} or GND to ensure proper device operation.

(2) Limits are 100% production tested at 25°C. Limits over the operating temperature range are ensured through correlations using statistical quality control (SQC) method.

(3) Typical values represent the most likely parametric norm as determined at the time of characterization. Actual typical values may vary over time and will also depend on the application and configuration.

8.3 Timing Requirements

over recommended operating free-air temperature range ($T_A = +25^\circ\text{C}$, unless otherwise noted) ⁽¹⁾

PARAMETER		$V_{CC}=1.8V\pm 0.15V$		$V_{CC}=2.5V\pm 0.2V$		$V_{CC}=3.3V\pm 0.3V$		$V_{CC}=5V\pm 0.5V$		UNIT
		MIN	MAX	MIN	MAX	MIN	MAX	MIN	MAX	
t_w	Pulse duration, LE high	11		5.5		3.5		2.5		ns
t_{su}	Setup time, data before LE↓	8		3.5		2		1.5		
t_h	Hold time, data after LE↓	2		1.5		1.5		1.5		

(1) This parameter is ensured by design and/or characterization and is not tested in production.

8.4 Switching Characteristics

over recommended operating free-air temperature range ($T_A = +25^\circ\text{C}$, unless otherwise noted) ⁽¹⁾

PARAMETER	FROM (INPUT)	TO (OUTPUT)	TEST CONDITIONS		TEMP	MIN	TYP	MAX	UNIT
t_{pd}	D	Q	$V_{CC}=1.8V\pm 0.15V$	$C_L=30pF, R_L=1k\Omega$	FULL	7	21	34	ns
			$V_{CC}=2V\pm 0.15V$	$C_L=30pF, R_L=1k\Omega$		5.2	15	25	
			$V_{CC}=2.5V\pm 0.2V$	$C_L=30pF, R_L=500\Omega$		3.5	10	16.5	
			$V_{CC}=3.3V\pm 0.3V$	$C_L=50pF, R_L=500\Omega$		2.6	8	13	
			$V_{CC}=5V\pm 0.5V$	$C_L=50pF, R_L=500\Omega$		1.7	7	11.5	
	LE	Q	$V_{CC}=1.8V\pm 0.15V$	$C_L=30pF, R_L=1k\Omega$	FULL	7.5	23	37	
			$V_{CC}=2V\pm 0.15V$	$C_L=30pF, R_L=1k\Omega$		6	16	26.5	
			$V_{CC}=2.5V\pm 0.2V$	$C_L=30pF, R_L=500\Omega$		3.2	10	16.5	
			$V_{CC}=3.3V\pm 0.3V$	$C_L=50pF, R_L=500\Omega$		2.6	8	13	
			$V_{CC}=5V\pm 0.5V$	$C_L=50pF, R_L=500\Omega$		1.6	7	11.5	
t_{en}	\overline{OE}	Q	$V_{CC}=1.8V\pm 0.15V$	$C_L=30pF, R_L=1k\Omega$	FULL	6.8	20	32.5	
			$V_{CC}=2V\pm 0.15V$	$C_L=30pF, R_L=1k\Omega$		5	15	25	
			$V_{CC}=2.5V\pm 0.2V$	$C_L=30pF, R_L=500\Omega$		3	9	15	
			$V_{CC}=3.3V\pm 0.3V$	$C_L=50pF, R_L=500\Omega$		2.8	7	12	
			$V_{CC}=5V\pm 0.5V$	$C_L=50pF, R_L=500\Omega$		1.6	6	10	
t_{dis}	\overline{OE}	Q	$V_{CC}=1.8V\pm 0.15V$	$C_L=30pF, R_L=1k\Omega$	FULL	5.8	17	28	
			$V_{CC}=2V\pm 0.15V$	$C_L=30pF, R_L=1k\Omega$		4.5	13	22	
			$V_{CC}=2.5V\pm 0.2V$	$C_L=30pF, R_L=500\Omega$		3.2	9	15	
			$V_{CC}=3.3V\pm 0.3V$	$C_L=50pF, R_L=500\Omega$		2.5	7	12	
			$V_{CC}=5V\pm 0.5V$	$C_L=50pF, R_L=500\Omega$		1.6	6	10	

(1) This parameter is ensured by design and/or characterization and is not tested in production.

8.5 Operating Characteristics

$T_A = +25^\circ\text{C}$

PARAMETER		TEST CONDITIONS	$V_{CC} = 1.8V$	$V_{CC} = 2.5V$	$V_{CC} = 3.3V$	$V_{CC} = 5V$	UNIT
			TYP	TYP	TYP	TYP	
C_{pd} (Power dissipation capacitance)	Outputs enabled	$f = 10\text{ MHz}$	11	13	16	20	pF
	Outputs disabled		3	3	3	4	

9 Parameter Measurement Information

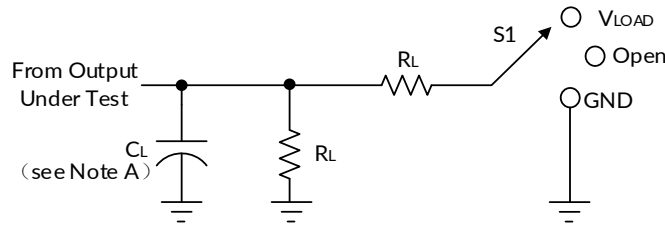

TEST	S1
t_{PLH}/t_{PHL}	Open
t_{PLZ}/t_{PZL}	V_{LOAD}
t_{PHZ}/t_{PZH}	GND

V_{CC}	INPUTS		V_M	V_{LOAD}	C_L	R_L	V_{Δ}
	V_I	t_r/t_f					
$1.8V \pm 0.15V$	V_{CC}	$\leq 2ns$	$V_{CC}/2$	$2 \times V_{CC}$	30pF	1k Ω	0.15V
$2.5V \pm 0.2V$	V_{CC}	$\leq 2ns$	$V_{CC}/2$	$2 \times V_{CC}$	30pF	500 Ω	0.15V
$3.3V \pm 0.3V$	3V	$\leq 2.5ns$	1.5V	6V	50pF	500 Ω	0.3V
$5V \pm 0.5V$	V_{CC}	$\leq 2.5ns$	$V_{CC}/2$	$2 \times V_{CC}$	50pF	500 Ω	0.3V

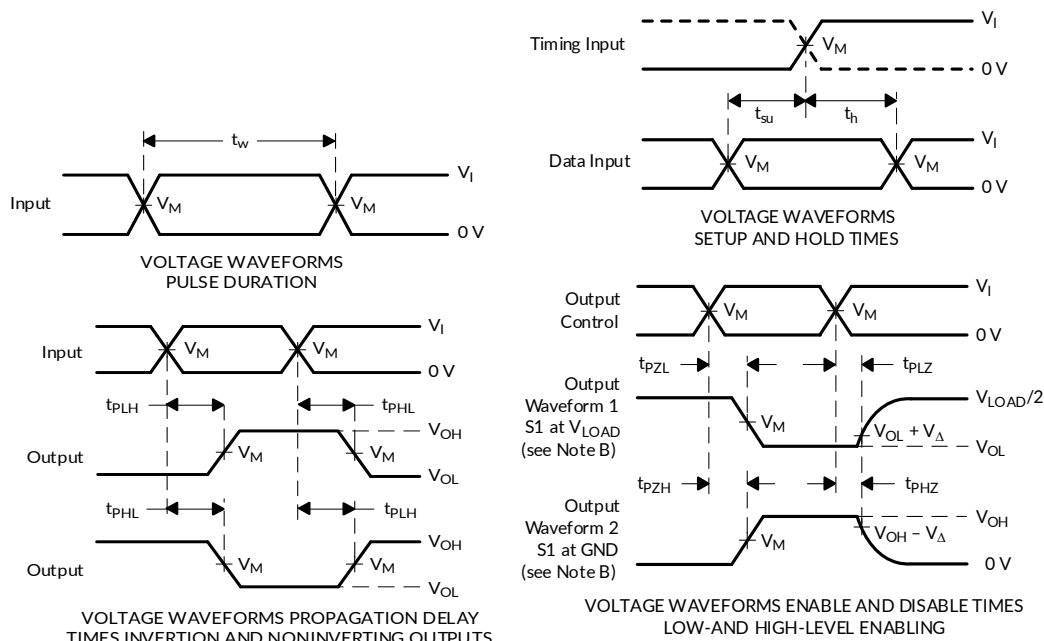

- NOTES: A. C_L includes probe and jig capacitance.
 B. Waveform 1 is for an output with internal conditions such that the output is low, except when disabled by the output control. Waveform 2 is for an output with internal conditions such that the output is high, except when disabled by the output control.
 C. All input pulses are supplied by generators having the following characteristics: $PRR \leq 10 \text{ MHz}$, $Z_O = 50\Omega$.
 D. The outputs are measured one at a time, with one transition per measurement.
 E. t_{PLZ} and t_{PHZ} are the same as t_{dis} .
 F. t_{PZL} and t_{PZH} are the same as t_{en} .
 G. t_{PLH} and t_{PHL} are the same as t_{pd} .
 H. All parameters and waveforms are not applicable to all devices.

Figure 1. Load Circuit and Voltage Waveforms

10 Detailed Description

10.1 Overview

A buffered output-enable (\overline{OE}) input can be used to place the output in either a normal logic state (high or low logic levels) or the high-impedance state. In the high-impedance state, the output neither loads nor drives the bus lines significantly. The high-impedance state and increased drive provide the capability to drive bus lines without interface or pullup components. To ensure the high-impedance state during power up or power down, \overline{OE} should be tied to V_{CC} through a pullup resistor; the minimum value of the resistor is determined by the current-sinking capability of the driver. This device is fully specified for partial-power-down applications using I_{off} . The I_{off} circuitry disables the outputs, preventing damaging current backflow through the device when it is powered down.

10.2 Functional Block Diagram

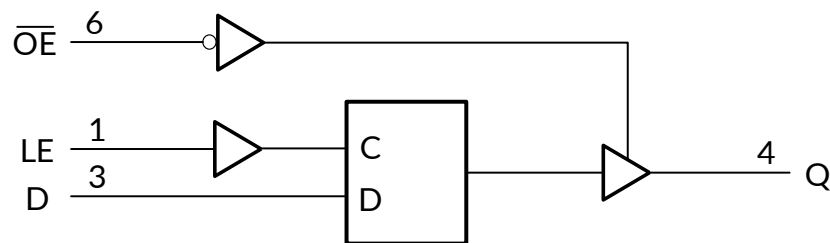

Figure 2. Logic Diagram (Positive Logic)

10.3 Feature Description

10.3.1 Partial Power Down (I_{off})

The inputs and outputs for this device enter a high impedance state when the supply voltage is 0V. The maximum leakage into or out of any input or output pin on the device is specified by I_{off} in the Electrical Characteristics.

10.3.2 Over-Voltage Tolerant Inputs

Input signals to this device can be driven above the supply voltage so long as they remain below the maximum input voltage value specified in the Absolute Maximum Ratings.

11 Application and Implementation

Information in the following applications sections is not part of the Runic component specification, and Runic does not warrant its accuracy or completeness. Runic's customers are responsible for determining suitability of components for their purposes. Customers should validate and test their design implementation to confirm system functionality.

11.1 Application Information

The RS1G373 latches can be used to store one bit of data. Figure 3 shows a typical application. The multiplexer is used to convert parallel data coming in from the latch into serial data using the A, B, and C select pins moving up in a sequence. With latch input low by a trigger event, the output Q holds the previous Q0 data entered until the LE pin is cleared.

11.2 Typical Application

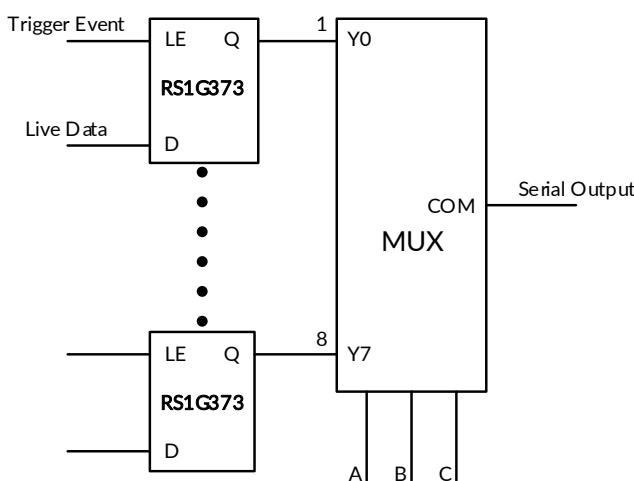

Figure 3. Latch Used with Multiplexer for Parallel to Serial Conversion

11.2.1 Design Requirements

This device uses CMOS technology and has balanced output drive. Take care to avoid bus contention because it can drive currents that would exceed maximum limits. The high drive also creates fast edges into light loads, so routing and load conditions must be considered to prevent ringing.

11.2.2 Detailed Design Procedure

1. Recommended Input Conditions

- For rise time and fall time specifications, see $\Delta t/\Delta V$ in Recommended Operating Conditions.
- For specified High and low levels, see V_{IH} and V_{IL} in Recommended Operating Conditions.
- Inputs are overvoltage tolerant allowing them to go as high as 5.5 V at any valid V_{CC} .

2. Recommended Output Conditions

- Load currents should not exceed 32 mA per output and 100 mA total through the part.
- Outputs must not be pulled above V_{CC} .

12 Power Supply Recommendations

The power supply can be any voltage between the minimum and maximum supply voltage rating located in Recommended Operating Conditions.

Each V_{CC} pin should have a good bypass capacitor to prevent power disturbance. For devices with a single supply, Runic recommends a 0.1 μ F bypass capacitor. If there are multiple V_{CC} pins, Runic recommends 0.01 μ F or 0.022 μ F bypass capacitor for each power pin. It is acceptable to parallel multiple bypass capacitors to reject different frequencies of noise. 0.1 μ F and 1 μ F capacitors are commonly used in parallel. The bypass capacitor should be installed as close to the power pin as possible for best results.

13 Layout

13.1 Layout Guidelines

When using multiple bit logic devices, inputs should not float. In many cases, functions or parts of functions of digital logic devices are unused. Some examples are when only two inputs of a triple-input AND gate are used, or when only 3 of the 4-buffer gates are used. Such input pins should not be left unconnected because the undefined voltages at the outside connections result in undefined operational states.

Specified in Figure 4 are rules that must be observed under all circumstances. All unused inputs of digital logic devices must be connected to a high or low bias to prevent them from floating. The logic level that should be applied to any particular unused input depends on the function of the device. Generally they will be tied to GND or VCC, whichever makes more sense or is more convenient.

Even low data rate digital signals can have high frequency signal components due to fast edge rates. When a PCB trace turns a corner at a 90° angle, a reflection can occur. A reflection occurs primarily because of the change of width of the trace. At the apex of the turn, the trace width increases to 1.414 times the width. This increase upsets the transmission-line characteristics, especially the distributed capacitance and self-inductance of the trace which results in the reflection. Not all PCB traces can be straight and therefore some traces must turn corners. Figure 5 shows progressively better techniques of rounding corners. Only the last example (BEST) maintains constant trace width and minimizes reflections.

13.2 Layout Example

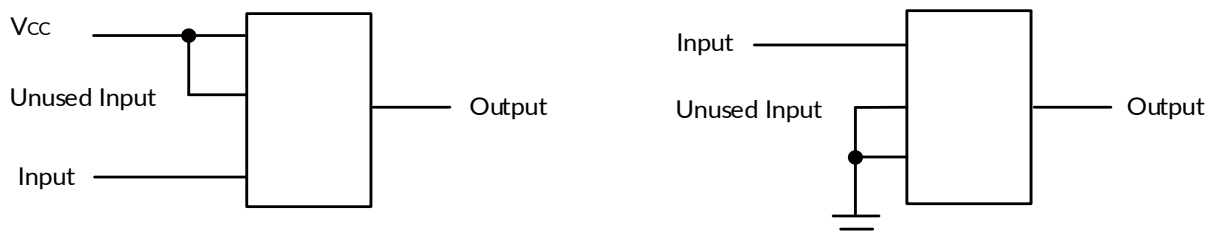

Figure 4. Proper Multiple Input Termination Diagram

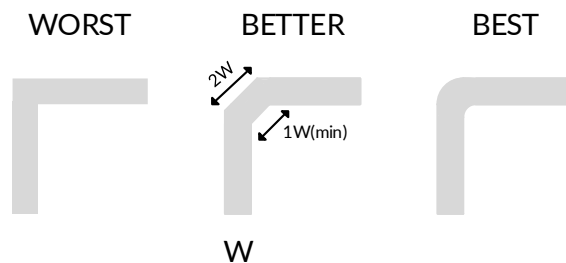
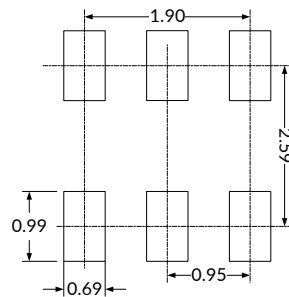
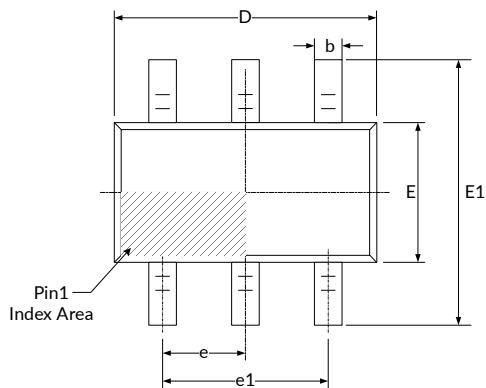
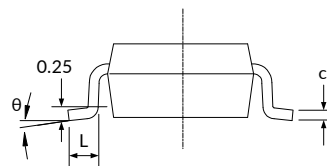
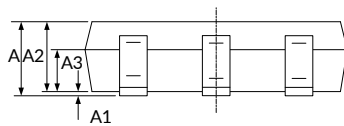

Figure 5. Trace Example

14 PACKAGE OUTLINE DIMENSIONS

SOT23-6 ⁽²⁾

RECOMMENDED LAND PATTERN (Unit: mm)

Symbol	Dimensions In Millimeters		Dimensions In Inches	
	Min	Max	Min	Max
A ⁽¹⁾		1.250		0.049
A1	0.000	0.150	0.000	0.006
A2	1.000	1.200	0.039	0.047
A3	0.600	0.700	0.024	0.028
b	0.340	0.450	0.013	0.018
c	0.100	0.200	0.004	0.008
D ⁽¹⁾	2.820	3.020	0.111	0.119
E ⁽¹⁾	1.500	1.700	0.059	0.067
E1	2.600	3.000	0.102	0.118
e	0.900	1.000	0.035	0.039
e1	1.800	2.000	0.071	0.079
L	0.300	0.600	0.012	0.024
θ	0°	8°	0°	8°

NOTE:

1. Plastic or metal protrusions of 0.15mm maximum per side are not included.
2. This drawing is subject to change without notice.

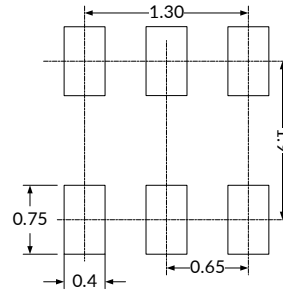
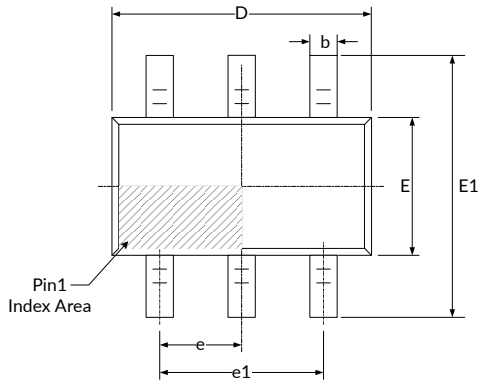
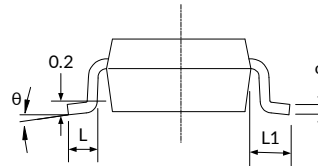
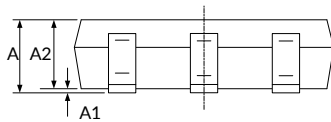
SOT363(SC70-6) ⁽³⁾

RECOMMENDED LAND PATTERN (Unit: mm)

Symbol	Dimensions In Millimeters		Dimensions In Inches	
	Min	Max	Min	Max
A ⁽¹⁾	0.900	1.100	0.035	0.043
A1	0.000	0.100	0.000	0.004
A2	0.900	1.000	0.035	0.039
b	0.150	0.350	0.006	0.014
c	0.110	0.175	0.004	0.007
D ⁽¹⁾	2.000	2.200	0.079	0.087
E ⁽¹⁾	1.150	1.350	0.045	0.053
E1	2.150	2.450	0.085	0.096
e	0.650(TYP)		0.026(TYP)	
e1	1.200	1.400	0.047	0.055
L	0.260	0.460	0.010	0.018
L1	0.525(REF) ⁽²⁾		0.021(REF) ⁽²⁾	
θ	0°	8°	0°	8°

NOTE:

1. Plastic or metal protrusions of 0.15mm maximum per side are not included.
2. REF is the abbreviation for Reference.
3. This drawing is subject to change without notice.

15 TAPE AND REEL INFORMATION

REEL DIMENSIONS

TAPE DIMENSION

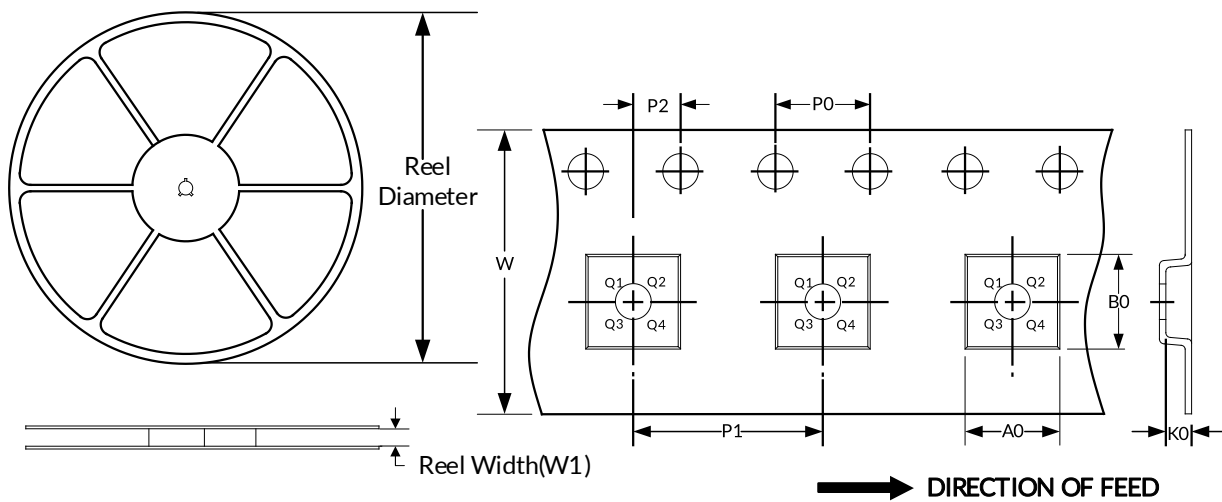

NOTE: The picture is only for reference. Please make the object as the standard.

KEY PARAMETER LIST OF TAPE AND REEL

Package Type	Reel Diameter	Reel Width(mm)	A0 (mm)	B0 (mm)	K0 (mm)	P0 (mm)	P1 (mm)	P2 (mm)	W (mm)	Pin1 Quadrant
SOT363(SC70-6)	7"	9.5	2.40	2.50	1.20	4.0	4.0	2.0	8.0	Q3
SOT23-6	7"	9.5	3.17	3.23	1.37	4.0	4.0	2.0	8.0	Q3

NOTE:

1. All dimensions are nominal.
2. Plastic or metal protrusions of 0.15mm maximum per side are not included.

IMPORTANT NOTICE AND DISCLAIMER

Jiangsu Runic Technology Co., Ltd. will accurately and reliably provide technical and reliability data (including data sheets), design resources (including reference designs), application or other design advice, WEB tools, safety information and other resources, without warranty of any defect, and will not make any express or implied warranty, including but not limited to the warranty of merchantability Implied warranty that it is suitable for a specific purpose or does not infringe the intellectual property rights of any third party.

These resources are intended for skilled developers designing with Runic products You will be solely responsible for: (1) Selecting the appropriate products for your application; (2) Designing, validating and testing your application; (3) Ensuring your application meets applicable standards and any other safety, security or other requirements; (4) Runic and the Runic logo are registered trademarks of Runic Incorporated. All trademarks are the property of their respective owners; (5) For change details, review the revision history included in any revised document. The resources are subject to change without notice. Our company will not be liable for the use of this product and the infringement of patents or third-party intellectual property rights due to its use.

X-ON Electronics

Largest Supplier of Electrical and Electronic Components

Click to view similar products for [Latches](#) category:

Click to view products by [RUNIC](#) manufacturer:

Other Similar products are found below :

[ML4875CS-5](#) [NLV14043BDR2G](#) [74F373DW](#) [NLV14044BDG](#) [5962-8863901RA](#) [5962-88639012A](#) [M22-30.01-2-D5-2-30/3/45](#) [M22-30.02-4-KW8-2-33/3/45](#) [M22DW-1333-21/3/45-90-07 \(9005\)](#) [GN 115-DK-26](#) [GN 115-SG-24](#) [GN 115-SG-50](#) [GN 115-VDE-22](#) [GN 115-VDE-34](#) [54FCT373ATLB](#) [NLV14043BDG](#) [NLV14515BDWR2G](#) [GN 115.10-DK-10-1-SR](#) [GN 115.10-DK-10-2-SR](#) [SN74HCS574QPWRQ1](#) [AiP74HCT573SA20.TB](#) [RS1G373XC6](#) [RS573XTSS20](#) [RS1G373XH6](#) [SN54ALS573CJ](#) [SN74HCS373QPWRQ1](#) [GN573D](#) [AiP74HCT573TA20.TB](#) [ZZ-16-103-01-S](#) [2.PM18.002-18](#) [2.PM18.006-18](#) [2.T18.006-18](#) [CQ/AA-KEY](#) [CQ/A-M22X1,5-45-28](#) [CQ/A-M22X1,5-45-32](#) [M22-2-D5-2-21-01-P](#) [CY74FCT2373CTSOC](#) [421283](#) [MIC5821YN](#) [MM74HC373WM](#) [MM74HC573MTCX](#) [MM74HC573WM](#) [74LCX373MTC](#) [74LVT16373MTDX](#) [74VHC373MX](#) [Z-0233-827-15](#) [MIC58P01YV](#) [74FCT573ATQG](#) [74LCX16373MTDX](#) [CQ/A-M22X1,5-45-16](#)