

4Ω,400MHz Bandwidth, Dual-Channel SPDT Analog Switch with Negative Signaling Capability

FEATURES

- **-3dB Bandwidth: 400MHz**
- **Supply Range: +2.5V to +5.5V**
- **Negative Signal Swing Capability: -2V to V_+**
- **Break-Before-Make Switching**
- **Fast t_{ON} , t_{OFF} Times**
- **1.8V Logic Control**
- **Extended Industrial Temperature Range: -40°C to +85°C**
- **Small Package Available in Green QFN-1.4x1.8-10L Package**

APPLICATIONS

- **Wearable Devices**
- **Battery-Operated Equipment**
- **Signal Gating, Chopping, Modulation or Demodulation (Modem)**
- **Portable Computing**
- **Cell Phones**

DESCRIPTION

The RS2117 is a bidirectional, dual-channel single-pole double-throw (SPDT) analog switch that is designed to operate from 2.5V to 5.5V, and the switches can handle negative signal down to -2.0V.

The device also offers a low ON-state resistance of 4Ω (typical), which is matched to within 1 Ω between channels. This device is available packaged in QFN-1.4x1.8-10L.

Functional Block Diagram

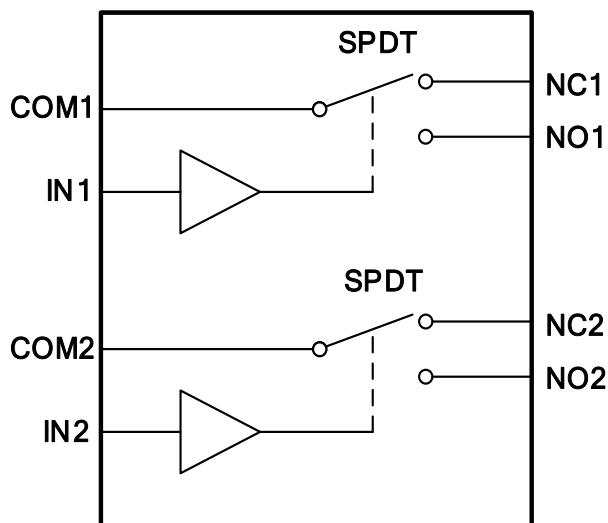

PIN CONFIGURATIONS

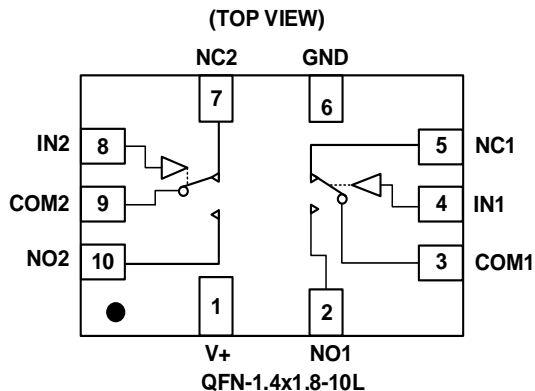

PIN DESCRIPTION

NAME	PIN	FUNCTION
V+	1	Power Supply
NO1, NO2	2,10	Normally-Open Terminal
COM1, COM2	3,9	Common Terminal
IN1, IN2	4,8	Digital Control Pin
NC1, NC2	5,7	Normally-Closed Terminal
GND	6	Ground

NOTE: NOX, NCX and COMX terminals may be an input or output.

FUNCTION TABLE

LOGIC	NO	NC
0	OFF	ON
1	ON	OFF

NOTE: Switches shown for logic "0" input.

PIN CONFIGURATIONS

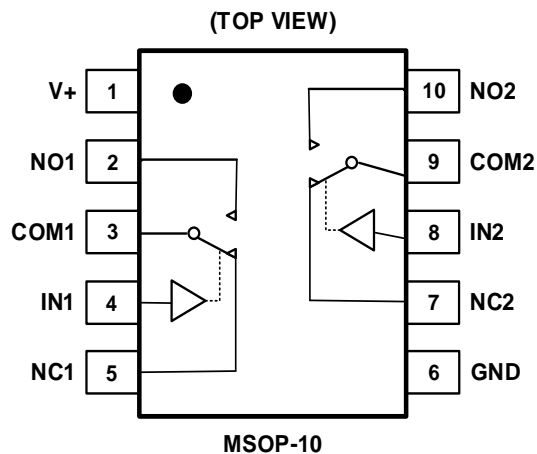

PIN DESCRIPTION

NAME	PIN	FUNCTION
V+	1	Power Supply
NO1, NO2	2,10	Normally-Open Terminal
COM1, COM2	3,9	Common Terminal
IN1, IN2	4,8	Digital Control Pin
NC1, NC2	5,7	Normally-Closed Terminal
GND	6	Ground

NOTE: NOX, NCX and COMX terminals may be an input or output.

FUNCTION TABLE

LOGIC	NO	NC
0	OFF	ON
1	ON	OFF

NOTE: Switches shown for logic "0" input.

ABSOLUTE MAXIMUM RATINGS ⁽¹⁾

V+, IN to GND.....	-0.3V to 6.0V
Analog Voltage Range ⁽²⁾	-2.0 to (V+) + 0.3V
Digital Voltage Range ⁽²⁾	-0.3 to (V+) + 0.3V
Continuous Current NO, NC, or COM.....	±100mA
Peak Current NO, NC, or COM.....	±150mA
Storage Temperature	-65°C to +150°C
Operating Temperature	-40°C to +85°C
Junction Temperature.....	+150°C
Package Thermal Resistance @ T _A = +25°C	
QFN-1.4x1.8-10L.....	120°C/W
Lead Temperature (Soldering, 10s)	260°C
ESD Susceptibility	
HBM	2000V
MM	200V



ESD SENSITIVITY CAUTION

ESD damage can range from subtle performance degradation to complete device failure. Precision integrated circuits may be more susceptible to damage because very small parametric changes could cause the device not to meet its published specifications.

- (1) Stresses above these ratings may cause permanent damage. Exposure to absolute maximum conditions for extended periods may degrade device reliability. These are stress ratings only, and functional operation of the device at these or any other conditions beyond those specified is not implied.
- (2) Input terminals are diode-clamped to the power-supply rails. Input signals that can swing more than 0.3V beyond the supply rails should be current-limited to 10mA or less.

PACKAGE/ORDERING INFORMATION

PRODUCT	ORDERING NUMBER	TEMPERATURE RANGE	PACKAGE LEAD	PACKAGE MARKING ⁽¹⁾	PACKAGE OPTION
RS2117	RS2117YUTQK10	-40°C ~+85°C	QFN-1.4x1.8-10L	2117X	Tape and Reel,4000
RS2117	RS2117YN	-40°C ~+85°C	MSOP-10	RS2117	Tape and Reel,3000

(1) NOTE: X = Date Code

MARKING INFORMATION

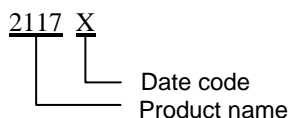



ELECTRICAL CHARACTERISTICS

$V_+ = 5.0\text{ V}$, $T_A = -40^\circ\text{C}$ to 85°C (unless otherwise noted)

PARAMETER	SYMBOL	CONDITIONS	V+	T _A	MIN	TYP	MAX	UNITS
ANALOG SWITCH								
Analog Signal Range	V_{NO}, V_{NC}, V_{COM}	$2.5\text{V} \leq V_+ \leq 3.5\text{V}$		FULL	-2.0		V+	V
		$3.5\text{V} \leq V_+ \leq 5.5\text{V}$			(V+)-5.5	V+		
On-Resistance	R_{ON}	$0 \leq (V_{NO} \text{ or } V_{NC}) \leq V_+$, $I_{COM} = -10\text{mA}$, Switch ON, See Figure 1	5V	+25°C		4	7	Ω
				FULL			7.5	Ω
			3.3V	+25°C		6	9	Ω
				FULL			9.5	Ω
On-Resistance Match Between Channels	ΔR_{ON}	$0 \leq (V_{NO} \text{ or } V_{NC}) \leq V_+$, $I_{COM} = -10\text{mA}$, Switch ON, See Figure 1	5V	+25°C		0.15	0.5	Ω
				FULL			0.6	Ω
			3.3V	+25°C		0.25	0.85	Ω
				FULL			1.0	Ω
On-Resistance Flatness	$R_{FLAT(ON)}$	$0 \leq (V_{NO} \text{ or } V_{NC}) \leq V_+$, $I_{COM} = -10\text{mA}$, Switch ON, See Figure 1	5V	+25°C		1	2	Ω
				FULL			2.5	Ω
			3.3V	+25°C		3	5	Ω
				FULL			5.4	Ω
NC, NO OFF Leakage Current	$I_{NC(OFF)}, I_{NO(OFF)}$	$V_{NO} \text{ or } V_{NC} = 0.3\text{V}$, $V_+/2$ $V_{COM} = V_+/2$, 0.3V See Figure 2	2.5V to 5.5V	FULL			1	μA
NC, NO, COM ON Leakage Current	$I_{NC(ON)}, I_{NO(ON)}, I_{COM(ON)}$	$V_{NO} \text{ or } V_{NC} = 0.3\text{V}$, Open $V_{COM} = \text{Open}$, 0.3V See Figure 3	2.5V to 5.5V	FULL			1	μA
DIGITAL CONTROL INPUTS⁽¹⁾								
Input High Voltage	V_{INH}		5V	FULL	1.5			V
			3.3V	FULL	1.3			V
Input Low Voltage	V_{INL}		5V	FULL			0.5	V
			3.3V	FULL			0.4	V
Input Leakage Current	I_{IN}	$V_{IN} = V_{IO} \text{ or } 0$	2.5V to 5.5V	FULL			1	μA

(1) All unused digital inputs of the device must be held at V_{IO} or GND to ensure proper device operation.



ELECTRICAL CHARACTERISTICS (continued)

V+ = 5.0 V, TEMP= -40°C to 85°C (unless otherwise noted)

PARAMETER	SYMBOL	CONDITIONS	V+	TEMP	MIN	TYP	MAX	UNITS
DYNAMIC CHARACTERISTICS								
Turn-On Time	t _{ON}	V _{COM} = V+, R _L = 300Ω, C _L = 35pF, See Figure 5	5V	+25°C		15		ns
			3.3V			25		
Turn-Off Time	t _{OFF}	V _{COM} = V+, R _L = 300Ω, C _L = 35pF, See Figure 5	5V	+25°C		10		ns
			3.3V			15		
Break-Before-Make Time Delay	t _{BBM}	V _{NO1} = V _{NC1} = V _{NO2} = V _{NC2} = V+/2, R _L = 300Ω, C _L = 35pF, See Figure 6	5V	+25°C		5		ns
			3.3V			10		
Charge Injection	Q	V _G =GND, R _G =0Ω, C _L =1.0nF, See Figure 10	5V	+25°C		15		pC
			3.3V		+25°C		10	
Off Isolation	O _{ISO}	R _L = 50Ω, Switch OFF, See Figure 8	f = 1MHz	+25°C		-70		dB
			f = 10MHz	+25°C		-50		dB
-3dB Bandwidth	BW	Switch ON, R _L = 50Ω See Figure 7		+25°C		400		MHz
Channel-to-Channel Crosstalk	X _{TALK}	Signal=0dBm, R _L = 50Ω, C _L = 5pF, See Figure 9	f = 1MHz	+25°C		-72		dB
			f = 10MHz	+25°C		-52		dB
NC, NO OFF Capacitance	C _{NC(OFF)} , C _{NO(OFF)}	V _{NC} or V _{NO} =V+/2 or GND, Switch OFF See Figure 4		+25°C		10		pF
NC, NO, COM ON Capacitance	C _{NC(ON)} , C _{NO(ON)} , C _{COM(ON)}	V _{NC} or V _{NO} =V+/2 or GND, Switch ON See Figure 4		+25°C		25		pF
POWER REQUIREMENTS								
Power Supply Range	V+			FULL	2.5		5.5	V
Power Supply Current	I+	V _{IN} = GND or V+	5.5V	FULL			1	μA

TYPICAL CHARACTERISTICS

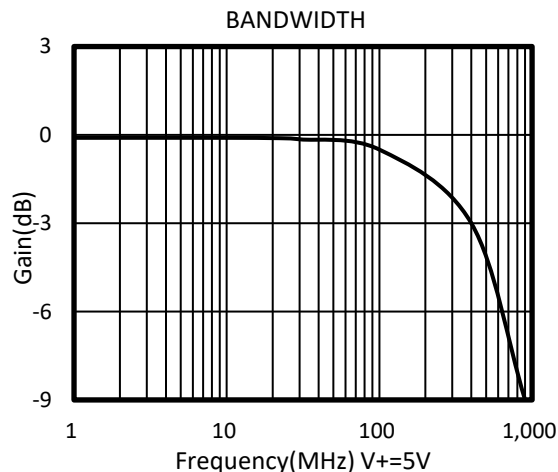
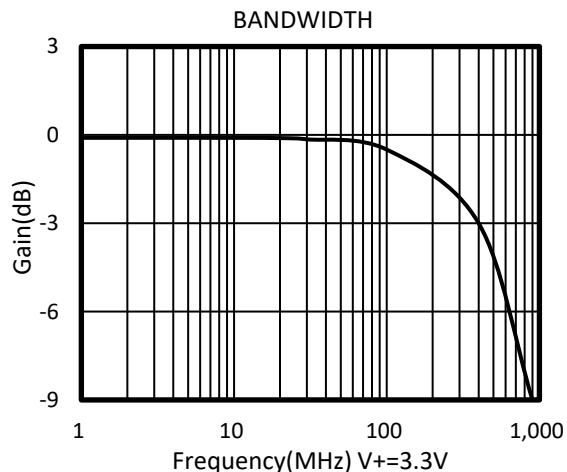

Typical Ron as a Function of Input Voltage (VI) for VI = 0 to V+

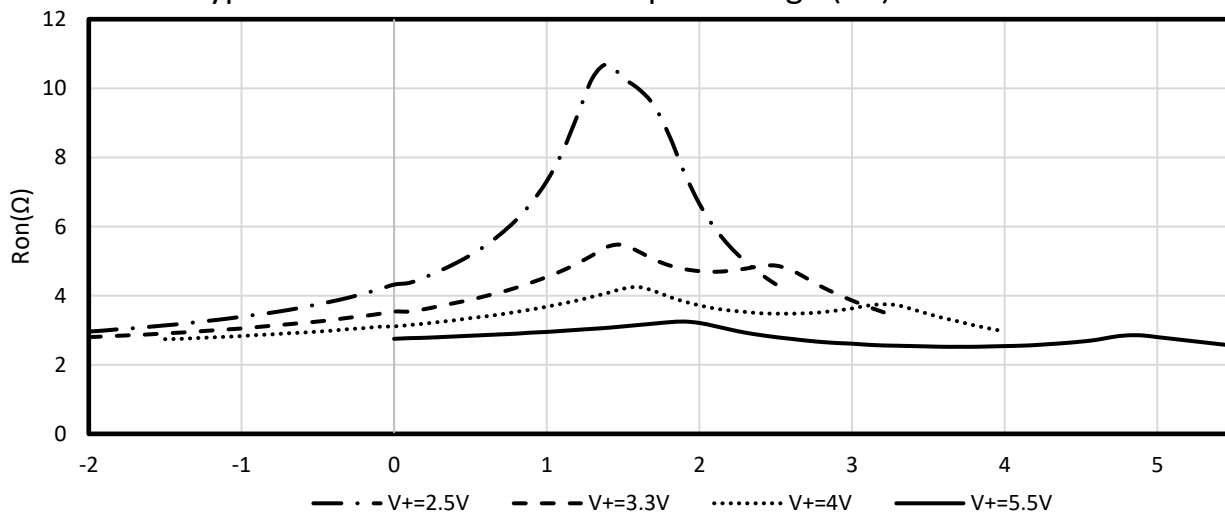

Parameter Measurement Information

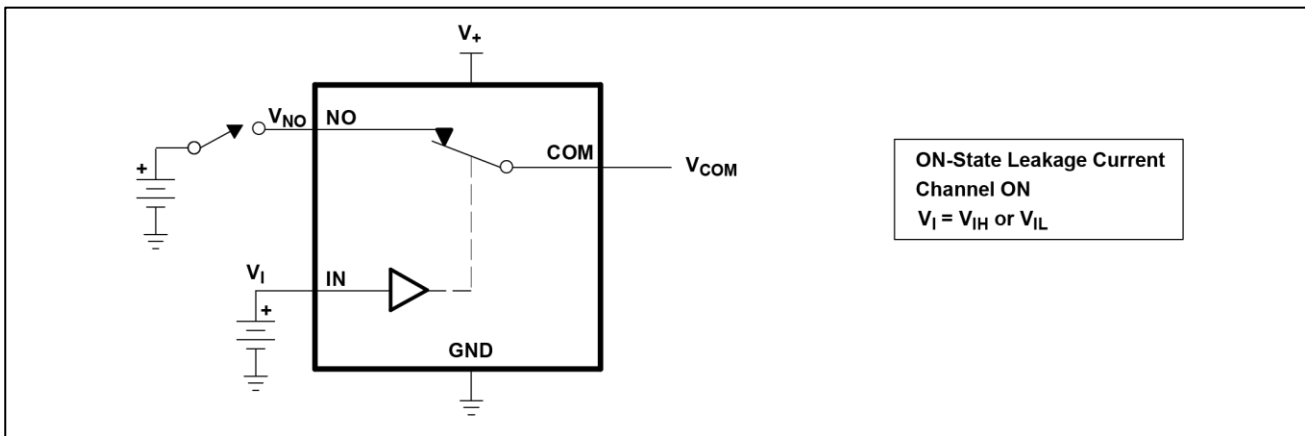
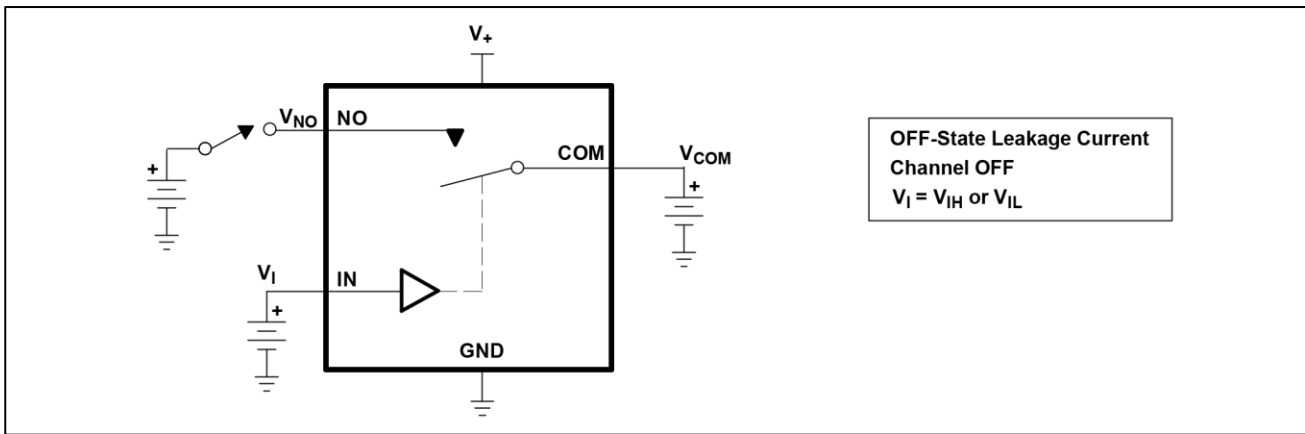
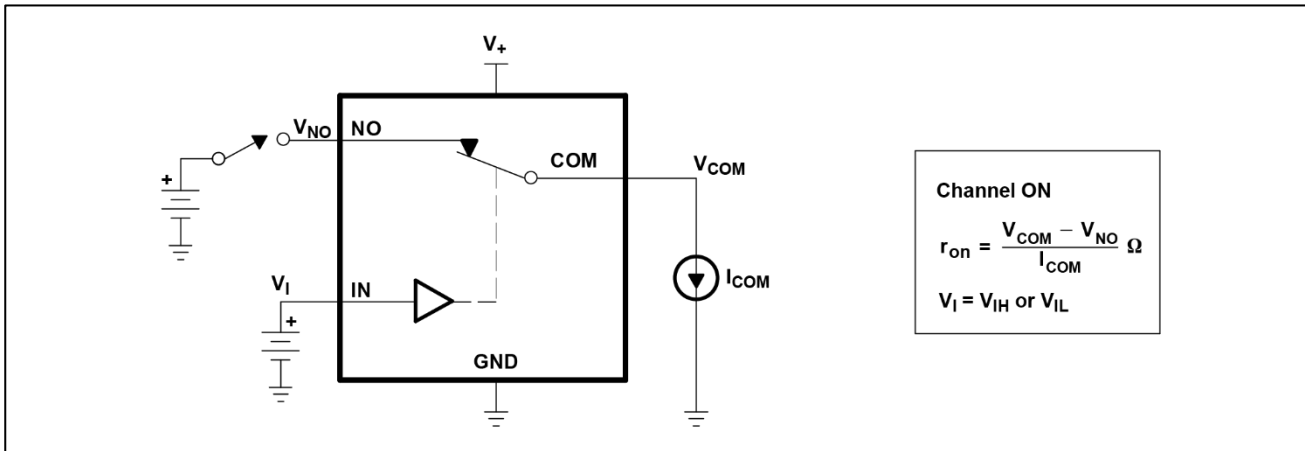

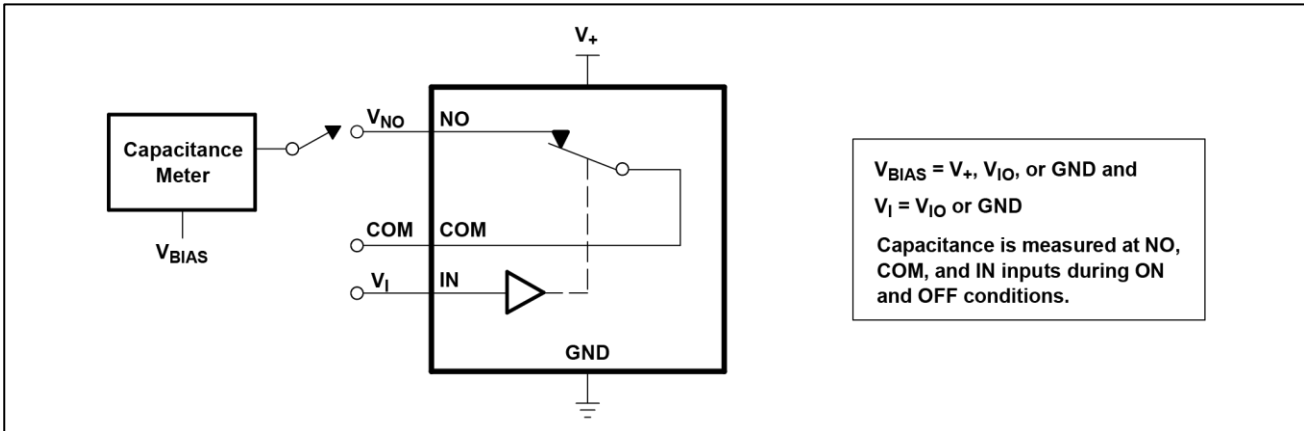

Figure 4. Capacitance (C_I , $C_{COM(OFF)}$, $C_{COM(ON)}$, $C_{NO(OFF)}$, $C_{NO(ON)}$)

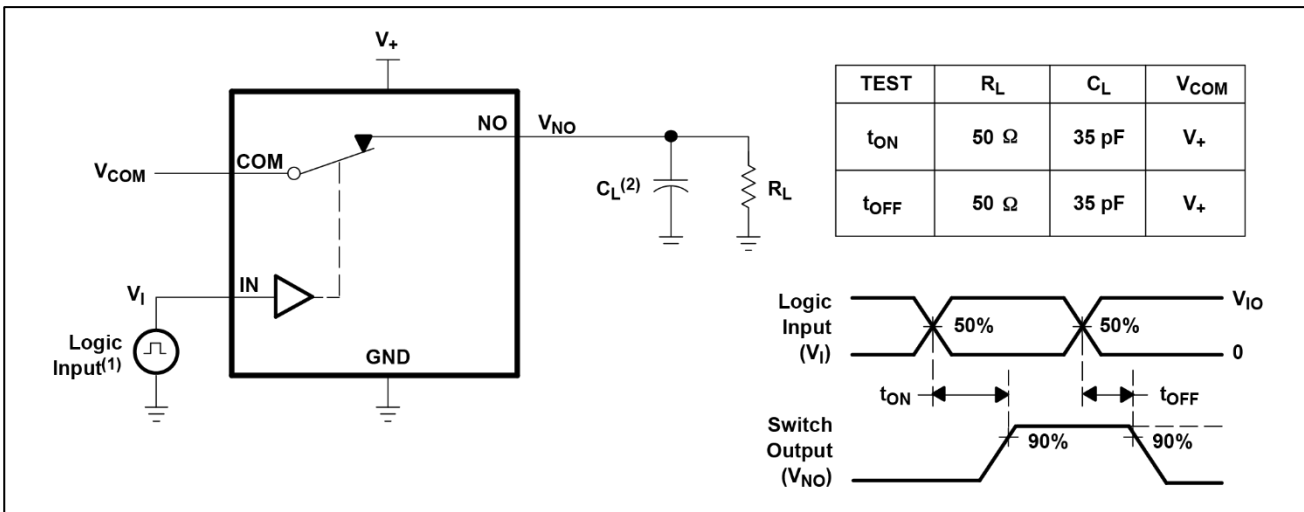

Figure 5. Turn-On (t_{ON}) and Turn-Off Time (t_{OFF})

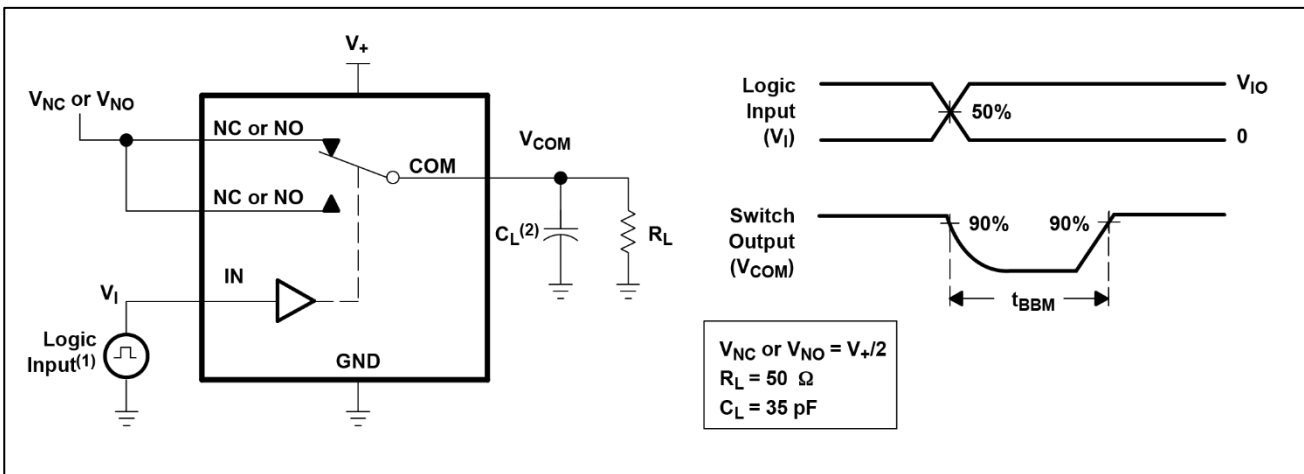

Figure 6. Break-Before-Make Time (t_{BBM})

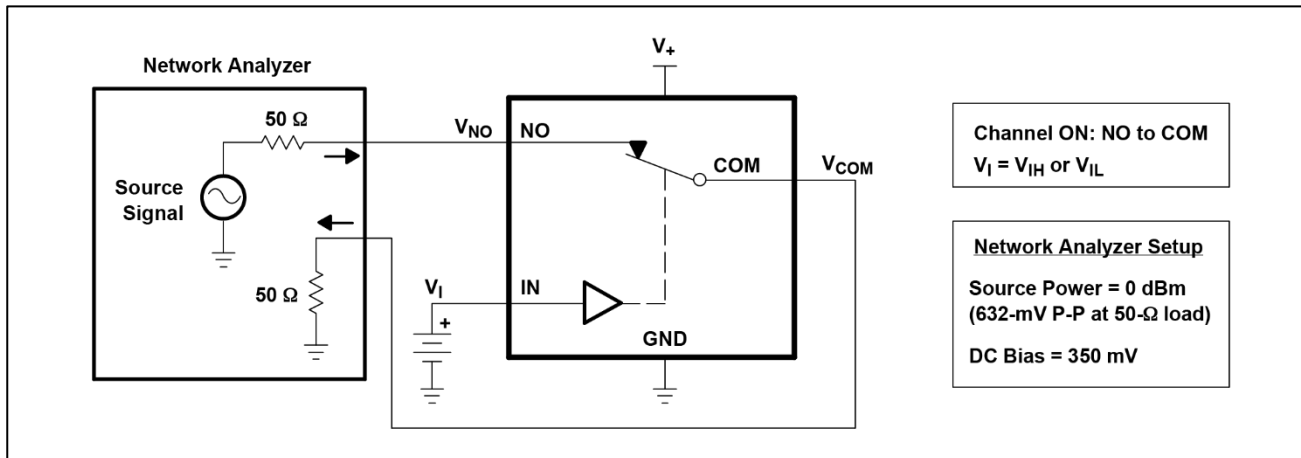

Figure 7. Bandwidth (BW)

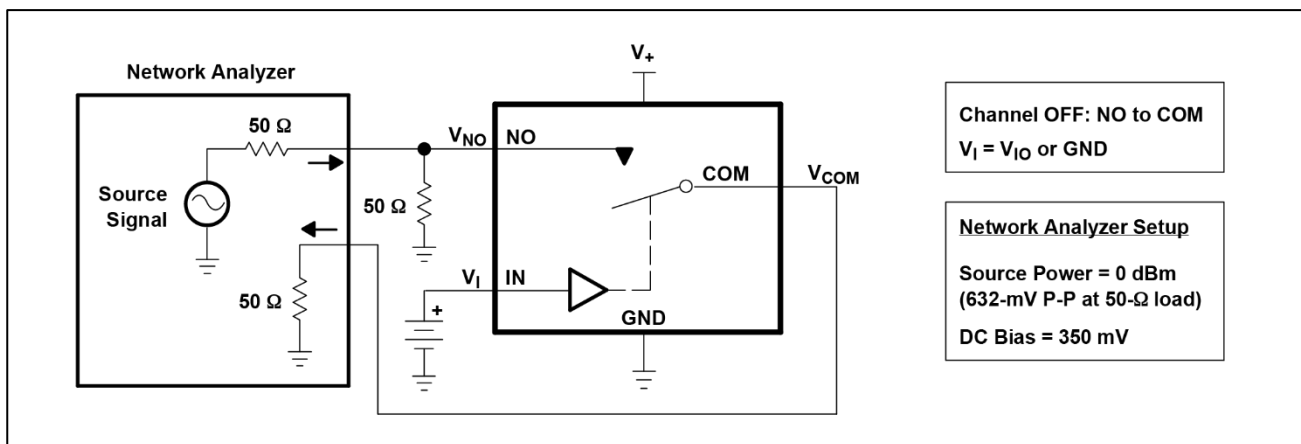

Figure 8. OFF Isolation (O_{ISO})

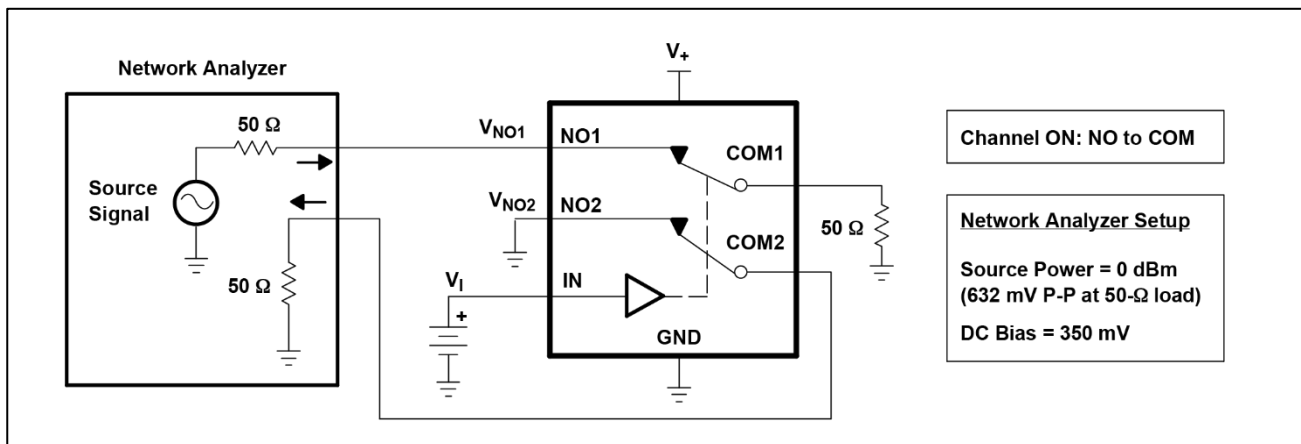

Figure 9. Crosstalk (X_{TALK})

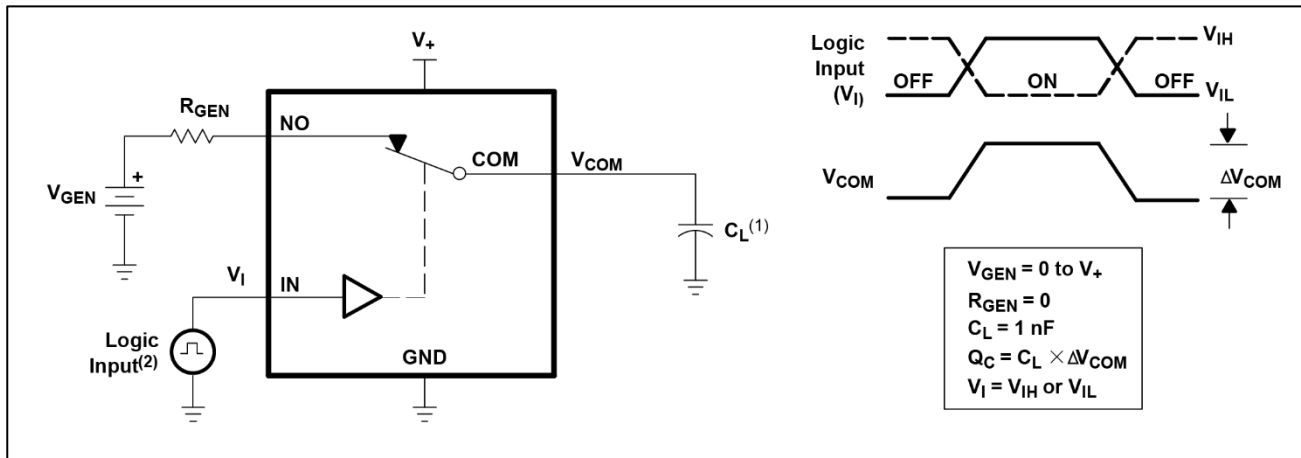

Figure 10. Charge Injection (Q_C)

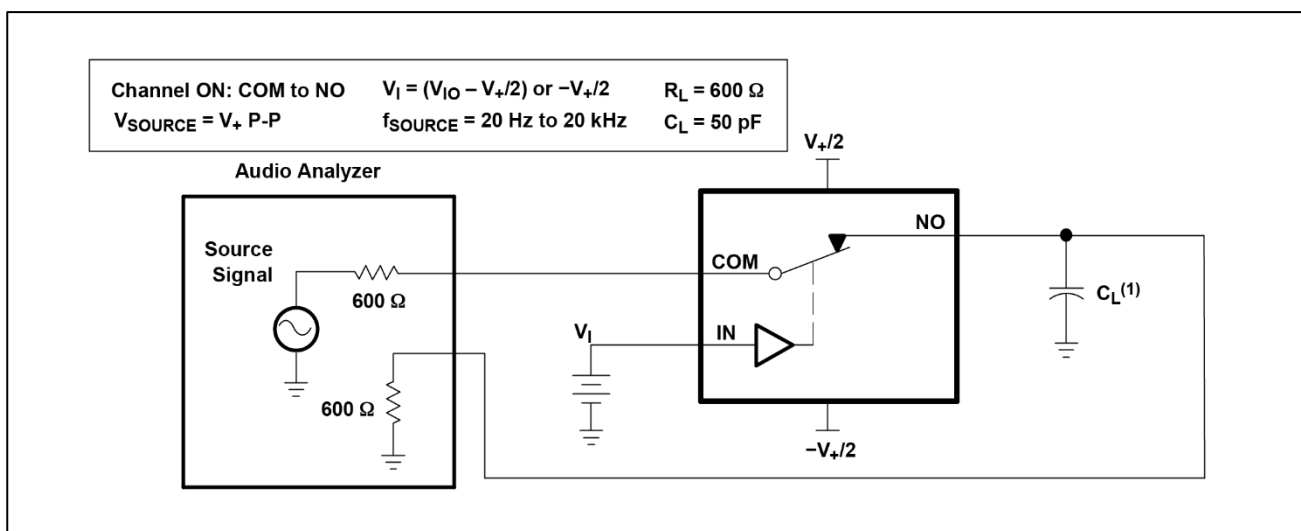

Figure11.Total Harmonic Distort

TYPICAL APPLICATION

Analog signals that range over the entire supply voltage V_{CC} to GND can be passed with very little change in ON-state resistance. The switches are bidirectional, so the NO, NC, and COM pins can be used as either inputs or outputs. Pull the digitally controlled input select pin IN to V_{CC} or GND to avoid unwanted switch states that could result if the logic control pin is left floating.

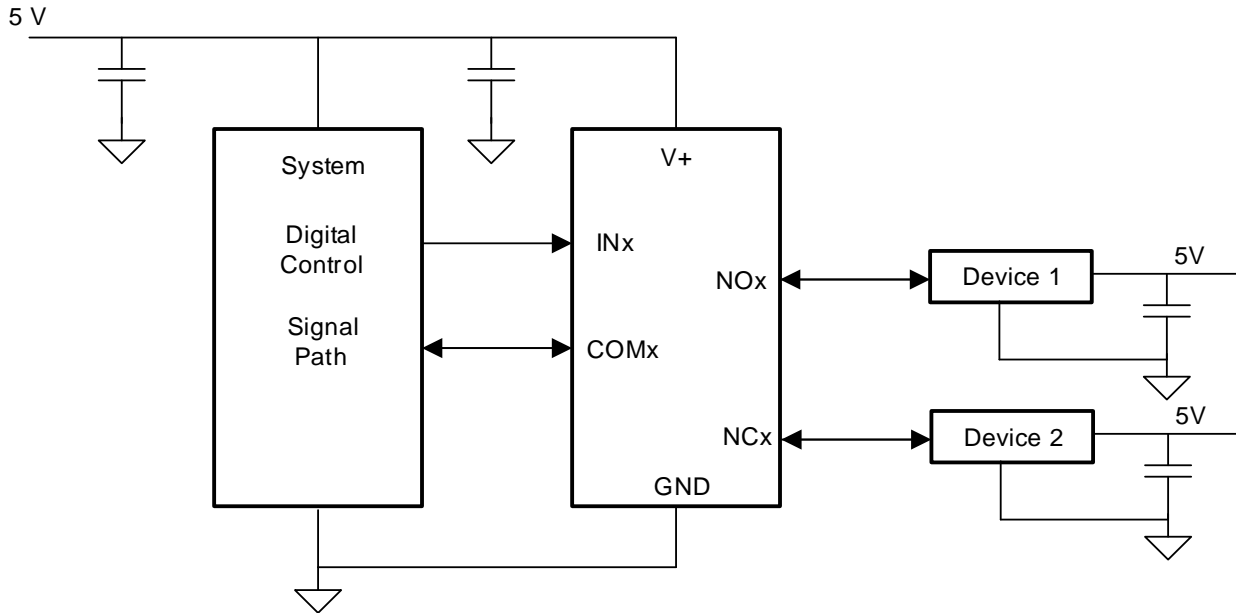
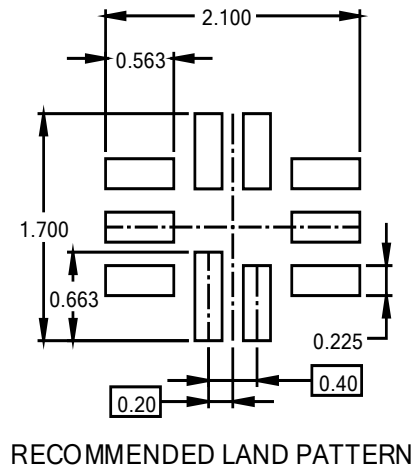
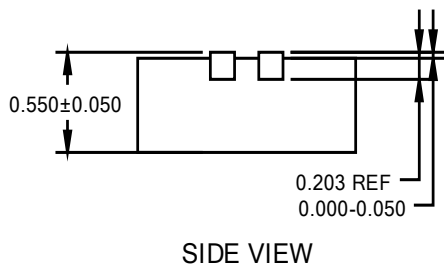
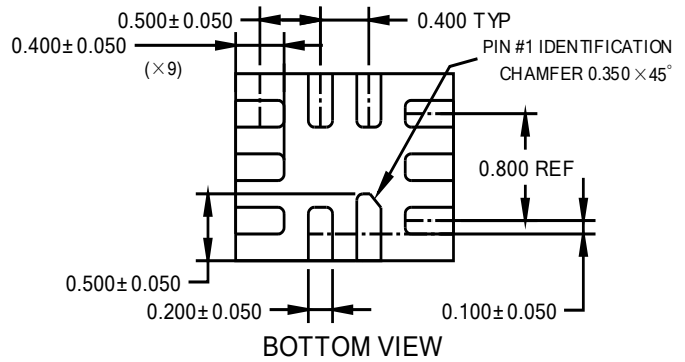
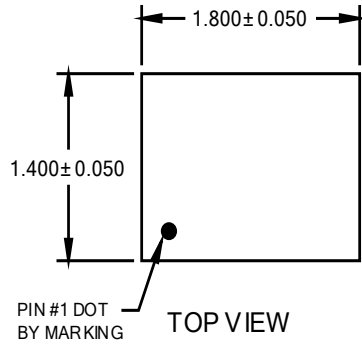
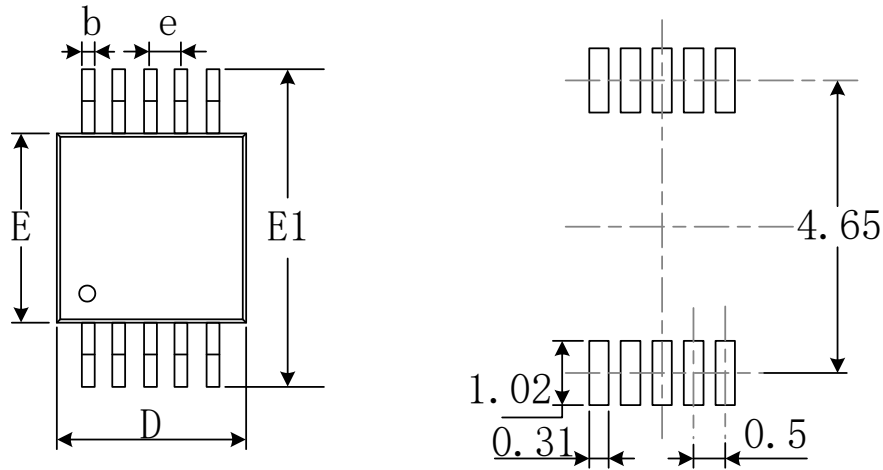

Figure 12. Typical Application Schematic

PACKAGE OUTLINE DIMENSIONS QFN-1.4x1.8-10L



MSOP-10



RECOMMENDED LAND PATTERN (Unit: mm)

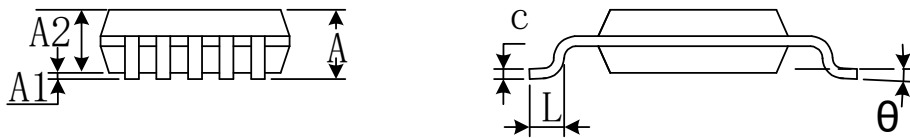

Symbol	Dimensions In Millimeters		Dimensions In Inches	
	Min	Max	Min	Max
A	0.820	1.100	0.032	0.043
A1	0.020	0.150	0.001	0.006
A2	0.750	0.950	0.030	0.037
b	0.180	0.280	0.007	0.011
c	0.090	0.230	0.004	0.009
D	2.900	3.100	0.114	0.122
e	0.50(BSC)		0.020(BSC)	
E	2.900	3.100	0.114	0.122
E1	4.750	5.050	0.187	0.199
L	0.400	0.800	0.016	0.031
θ	0°	6°	0°	6°

X-ON Electronics

Largest Supplier of Electrical and Electronic Components

Click to view similar products for [Analogue Switch ICs category](#):

Click to view products by [RUNIC manufacturer](#):

Other Similar products are found below :

[FSA3051TMX](#) [NLVAS4599DTT1G](#) [MAX4992EVB+T](#) [MAX4684ETB+T](#) [BCM6522IPBG](#) [BCM65300IFSBG](#) [MAX14764ETA+T](#)
[TMUX1113RSVR](#) [TMUX1112RSVR](#) [ADG1436TRUZ-EP](#) [BL4684C](#) [PE423422A](#) [PE42359SCAA](#) [PE42540F](#) [RS550YUCM12](#)
[ADGS1414DBCCZ](#) [ADG658YRUZ-REEL7](#) [RS2117YUTQK10](#) [RS2118YUTQK10](#) [RS2227XUTQK10](#) [SP2526A-1EN-L/TR](#) [FSA4157P6X](#)
[BA7603F-E2](#) [MAX4702EUE+](#) [MAX4617CUE+](#) [MAX4599EUT+T](#) [MAX4066ESD+](#) [MAX4052ACSE+](#) [MAX396CAI+](#) [MAX391CPE+](#)
[MAX4730EXT+T](#) [MAX314CPE+](#) [MAX4051AEEE+](#) [BU4066BCFV-E2](#) [MAX313CPE+](#) [BU4S66G2-TR](#) [TS3A4751PWR](#)
[NCN1154MUTAG](#) [DG444DY-E3](#) [NLAS4157DFT2G](#) [NLAS4599DFT2G](#) [NLAS7242MUTBG](#) [NLASB3157DFT2G](#) [NLAST4599DFT2G](#)
[NLAST4599DTT1G](#) [DG403DY-T1-E3](#) [MAX4714EXTT](#) [MAX392CPE](#) [BGSX22G2A10E6327XTSA1](#) [ADG1611BRUZ-REEL7](#)