

0.8Ω, Low Ron, Dual SPDT Analog Switch with Negative Rail Capability

FEATURES

- **Low ON-State Resistance:0.8Ω (TYP)**
- **Supply Range: +2.5V to +5.5V**
- **Negative Signal Swing Capability: -2V to V₊**
- **Break-Before-Make Switching**
- **Fast Switching Times**
- **1.8V Logic Control**
- **Rail-to-Rail Input and Output Operation**
- **Extended Industrial Temperature Range: -40°C to +85°C**
- **Available in Green QFN-1.4x1.8-10L Package**

DESCRIPTION

The RS2118 is a bidirectional, 2-channel single-pole double-throw (SPDT) analog switch that is designed to operate from 2.5V to 5.5V. The device features negative signal capability that allows signals below ground to pass through the switch without distortion.

The break-before-make feature prevents signal distortion during the transferring of a signal from one path to another. Low ON-state resistance, excellent channel-to-channel ON-state resistance matching, and minimal total harmonic distortion (THD) performance are ideal for audio applications. This device is available packaged in QFN-1.4x1.8-10L.

APPLICATIONS

- **Wearable Devices**
- **Battery-Operated Equipment**
- **Portable Instrumentation**
- **Cell Phones**
- **Automation Test Equipment**
- **Relay Replacement**

Functional Block Diagram

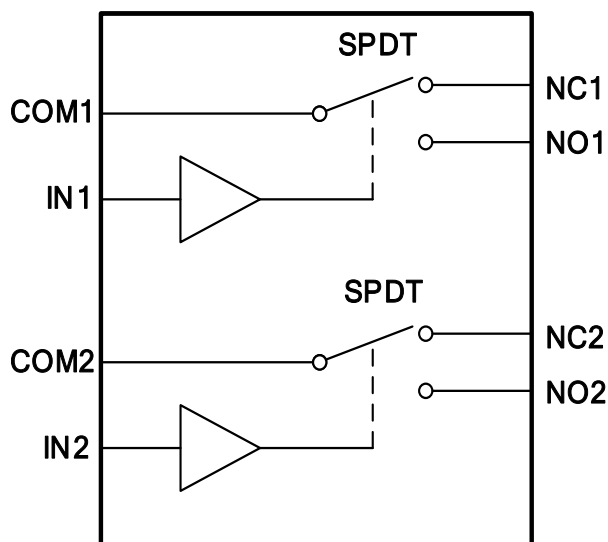

PIN CONFIGURATIONS

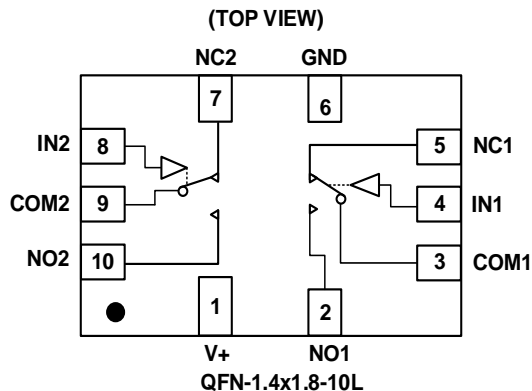

PIN DESCRIPTION

NAME	PIN	FUNCTION
V+	1	Power Supply
NO1, NO2	2,10	Normally-Open Terminal
COM1, COM2	3,9	Common Terminal
IN1, IN2	4,8	Digital Control Pin
NC1, NC2	5,7	Normally-Closed Terminal
GND	6	Ground

NOTE: NOX, NCX and COMX terminals may be an input or output.

FUNCTION TABLE

LOGIC	NO	NC
0	OFF	ON
1	ON	OFF

NOTE: Switches shown for logic "0" input.

ABSOLUTE MAXIMUM RATINGS ⁽¹⁾

V+, IN to GND.....	-0.3V to 6.0V
Analog Voltage Range ⁽²⁾	-2.0 to (V+) + 0.3V
Digital Voltage Range ⁽²⁾	-0.3 to (V+) + 0.3V
Continuous Current NO, NC, or COM.....	±250mA
Peak Current NO, NC, or COM.....	±350mA
Storage Temperature	-65°C to +150°C
Operating Temperature	-40°C to +85°C
QFN-1.4x1.8-10L.....	120°C/W
HBM	2000V
MM	200V

(1) Stresses above these ratings may cause permanent damage. Exposure to absolute maximum conditions for extended periods may degrade device reliability. These are stress ratings only, and functional operation of the device at these or any other conditions beyond those specified is not implied.

(2) Input terminals are diode-clamped to the power-supply rails. Input signals that can swing more than 0.3V beyond the supply rails should be current-limited to 10mA or less.



ESD SENSITIVITY CAUTION

ESD damage can range from subtle performance degradation to complete device failure. Precision integrated circuits may be more susceptible to damage because very small parametric changes could cause the device not to meet its published specifications.

PACKAGE/ORDERING INFORMATION

PRODUCT	ORDERING NUMBER	TEMPERATURE RANGE	PACKAGE LEAD	PACKAGE MARKING	PACKAGE OPTION
RS2118	RS2118YUTQK10	-40°C ~ +85°C	QFN-1.4x1.8-10L	2118X	Tape and Reel,4000

NOTE: X = Date Code

MARKING INFORMATION





ELECTRICAL CHARACTERISTICS

V+ = 5.0 V, TA = -40°C to 85°C (unless otherwise noted)

PARAMETER	SYMBOL	CONDITIONS	V+	TA	MIN	TYP	MAX	UNITS
ANALOG SWITCH								
Analog Signal Range	VNO, VNC, VCOM	2.5V ≤ V+ ≤ 3.5V		FULL	-2.0		V+	V
		3.5V ≤ V+ ≤ 5.5V			(V+)-5.5	V+		
On-Resistance	RON	0 ≤ (VNO or VNC) ≤ V+, ICOM = -10mA, Switch ON, See Figure 1	5V	+25°C		0.8	1.1	Ω
				FULL			1.3	Ω
			3.3V	+25°C		1.3	1.8	Ω
				FULL			2	Ω
On-Resistance Match Between Channels	ΔRON	0 ≤ (VNO or VNC) ≤ V+, ICOM = -10mA, Switch ON, See Figure 1	5V	+25°C		0.15	0.25	Ω
				FULL			0.3	Ω
			3.3V	+25°C		0.15	0.25	Ω
				FULL			0.3	Ω
On-Resistance Flatness	RFLAT(ON)	0 ≤ (VNO or VNC) ≤ V+, ICOM = -10mA, Switch ON, See Figure 1	5V	+25°C		0.15	0.25	Ω
				FULL			0.3	Ω
			3.3V	+25°C		0.4	0.6	Ω
				FULL			0.7	Ω
NC, NO OFF Leakage Current	INC(OFF), INO(OFF)	VNO or VNC = 0.3V, V+/2 VCOM = V+/2, 0.3V See Figure 2	2.5V to 5.5V	FULL			1	μA
NC, NO, COM ON Leakage Current	INC(ON), INO(ON), ICOM(ON)	VNO or VNC = 0.3V, Open VCOM = Open, 0.3V See Figure 3	2.5V to 5.5V	FULL			1	μA
DIGITAL CONTROL INPUTS⁽¹⁾								
Input High Voltage	VINH		5V	FULL	1.5			V
			3.3V	FULL	1.3			V
Input Low Voltage	VINL		5V	FULL			0.5	V
			3.3V	FULL			0.4	V
Input Leakage Current	IIN	VIN = VIO or 0	2.5V to 5.5V	FULL			1	μA

(1) All unused digital inputs of the device must be held at VIO or GND to ensure proper device operation.



ELECTRICAL CHARACTERISTICS (continued)

V+ = 5.0 V, TEMP= -40°C to 85°C (unless otherwise noted)

PARAMETER	SYMBOL	CONDITIONS	V+	TEMP	MIN	TYP	MAX	UNITS
DYNAMIC CHARACTERISTICS								
Turn-On Time	t _{ON}	V _{COM} = V+, R _L = 300Ω, C _L = 35pF, See Figure 5	5V	+25°C		15		ns
			3.3V			25		
Turn-Off Time	t _{OFF}	V _{COM} = V+, R _L = 300Ω, C _L = 35pF, See Figure 5	5V	+25°C		10		ns
			3.3V			15		
Break-Before-Make Time Delay	t _{BBM}	V _{NO1} = V _{NC1} = V _{NO2} = V _{NC2} = V+/2, R _L = 300Ω, C _L = 35pF, See Figure 6	5V	+25°C		5		ns
			3.3V			10		
Charge Injection	Q	V _G =GND, R _G =0Ω, C _L =1.0nF, See Figure 10	5V	+25°C		80		pC
			3.3V		+25°C		74	
Off Isolation	O _{ISO}	R _L = 50Ω, Switch OFF, See Figure 8	f = 1MHz	+25°C		-70		dB
			f = 10MHz	+25°C		-50		dB
-3dB Bandwidth	BW	Switch ON, R _L = 50Ω See Figure 7		+25°C		80		MHz
Channel-to-Channel Crosstalk	X _{TALK}	Signal=0dBm, R _L = 50Ω, C _L = 5pF, See Figure 9	f = 1MHz	+25°C		-72		dB
			f = 10MHz	+25°C		-52		dB
NC, NO OFF Capacitance	C _{NC(OFF)} , C _{NO(OFF)}	V _{NC} or V _{NO} =V+/2 or GND, Switch OFF See Figure 4		+25°C		40		pF
NC, NO, COM ON Capacitance	C _{NC(ON)} , C _{NO(ON)} , C _{COM(ON)}	V _{NC} or V _{NO} =V+/2 or GND, Switch ON See Figure 4		+25°C		85		pF
POWER REQUIREMENTS								
Power Supply Range	V+			FULL	2.5		5.5	V
Power Supply Current	I+	V _{IN} = GND or V+	5.5V	FULL			1	μA

TYPICAL CHARACTERISTICS

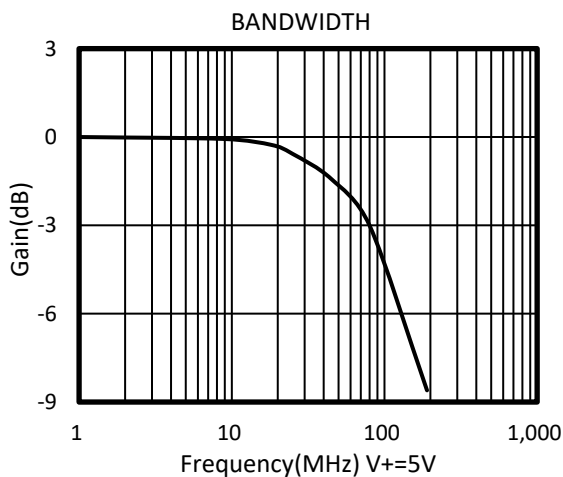
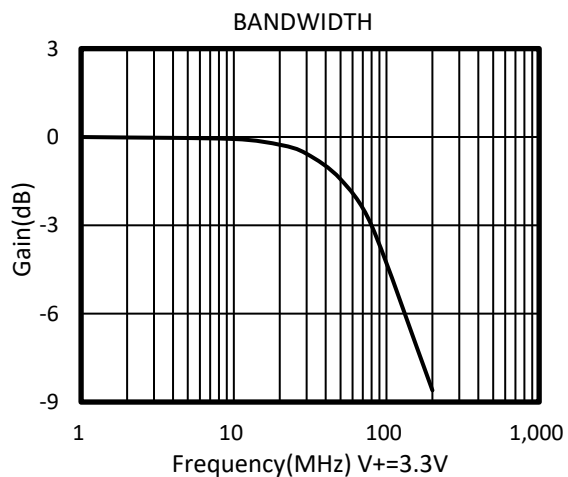

Typical Ron as a Function of Input Voltage (VI) for VI = 0 to V+

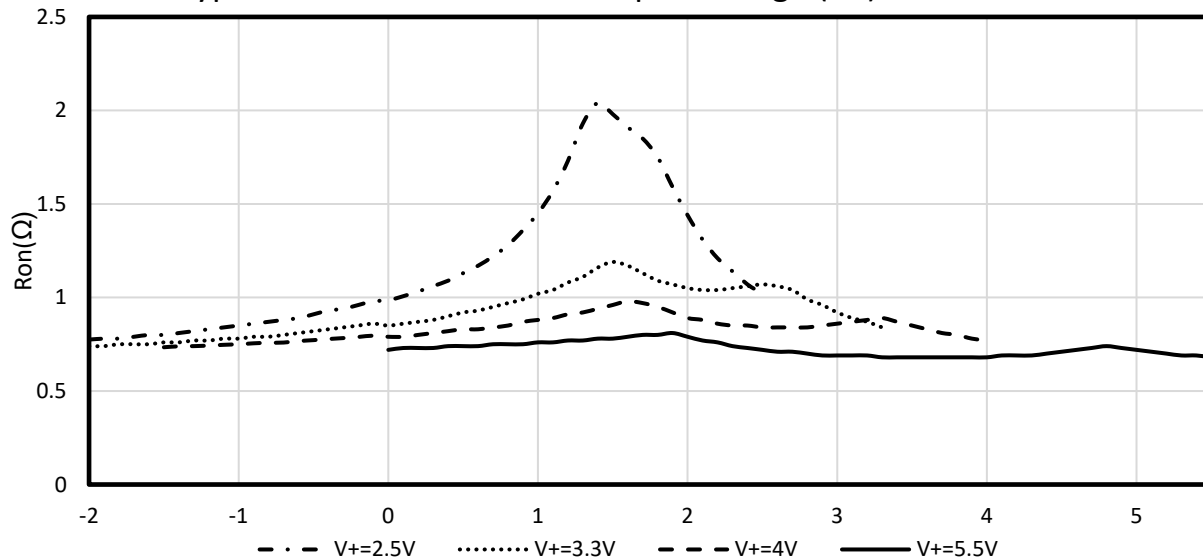

Parameter Measurement Information

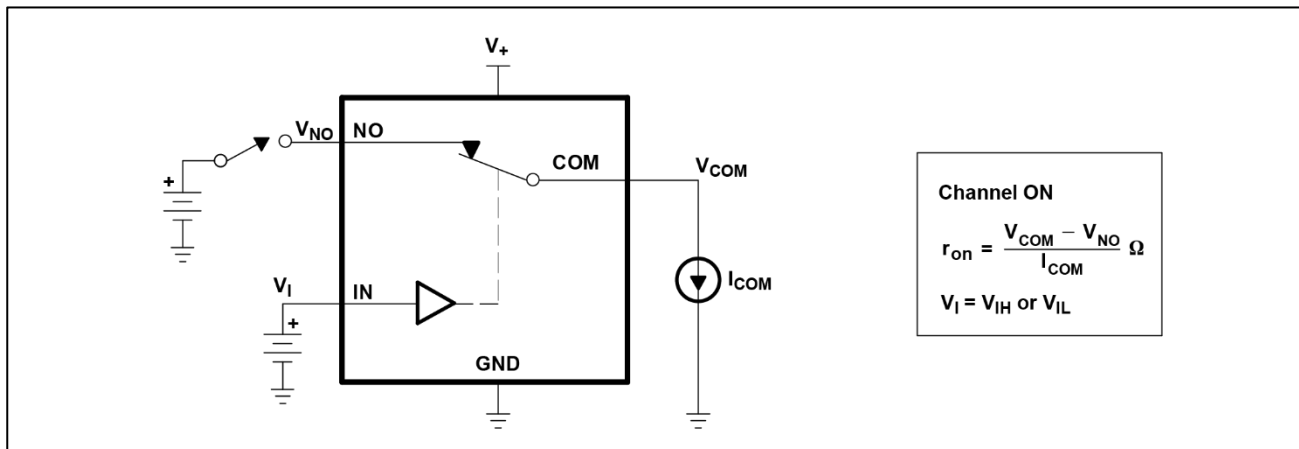

Figure 1.ON-State Resistance (r_{on})

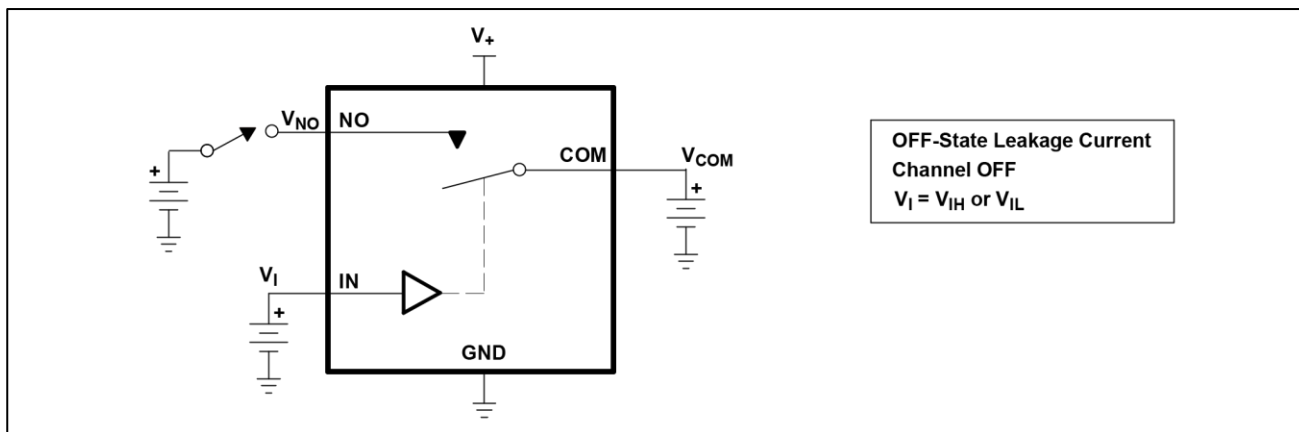

Figure 2.OFF-State Leakage Current ($I_{COM(OFF)}$, $I_{NO(OFF)}$)

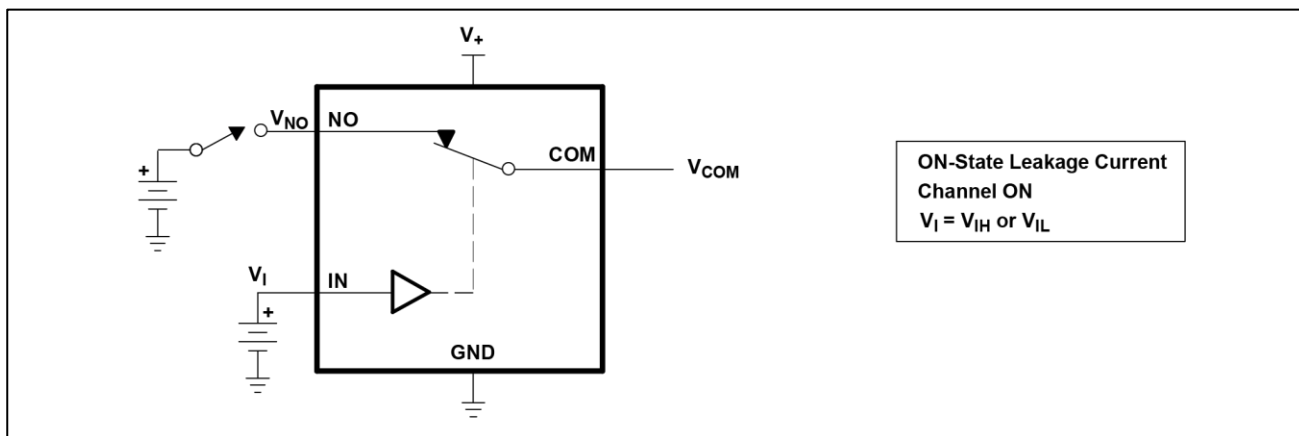

Figure 3. ON-State Leakage Current ($I_{COM(ON)}$, $I_{NO(ON)}$)

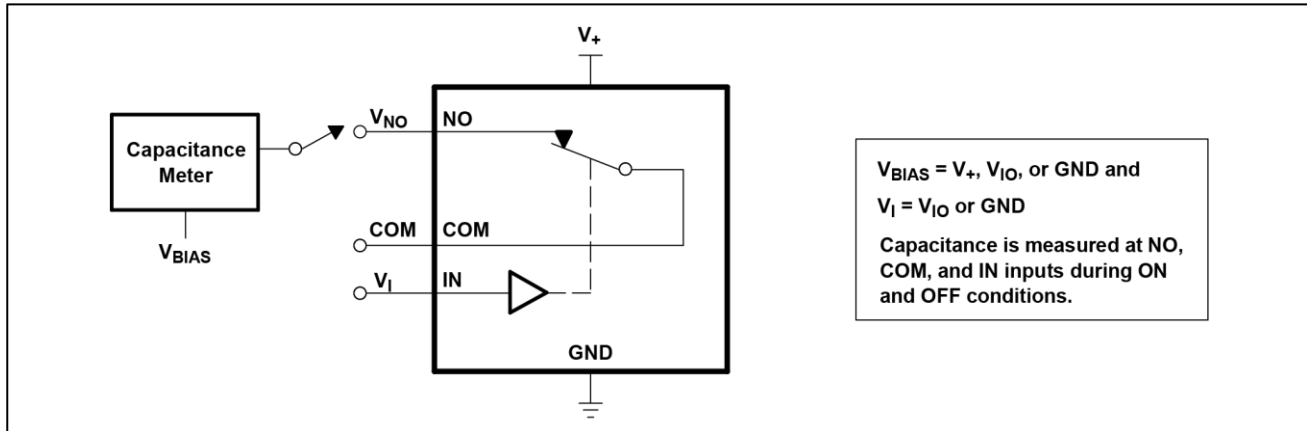

Figure 4. Capacitance (C_I , $C_{COM(OFF)}$, $C_{COM(ON)}$, $C_{NO(OFF)}$, $C_{NO(ON)}$)

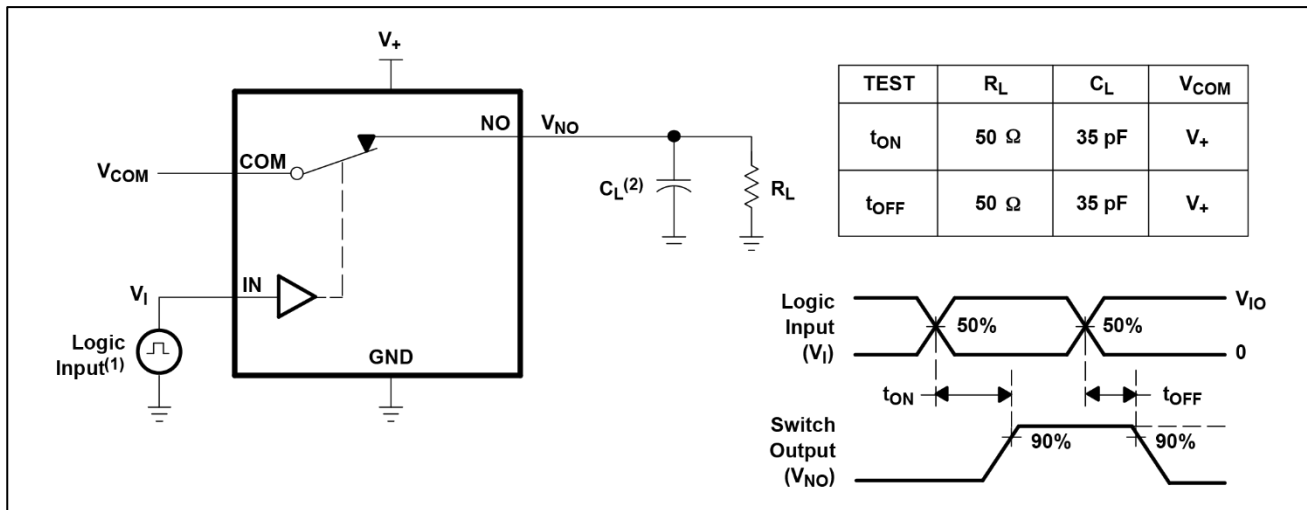

Figure 5. Turn-On (t_{ON}) and Turn-Off Time (t_{OFF})

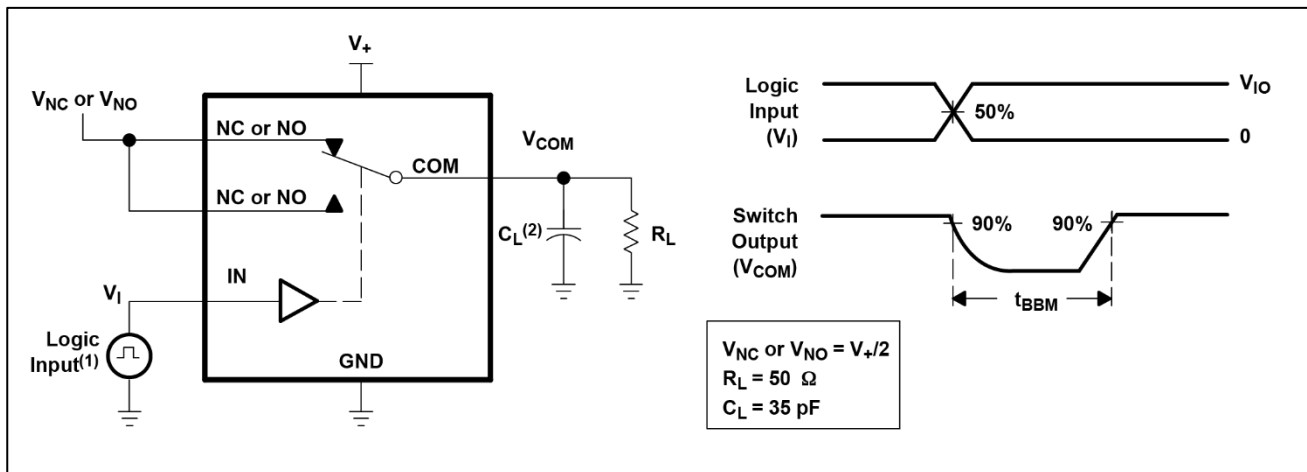

Figure 6. Break-Before-Make Time (t_{BBM})

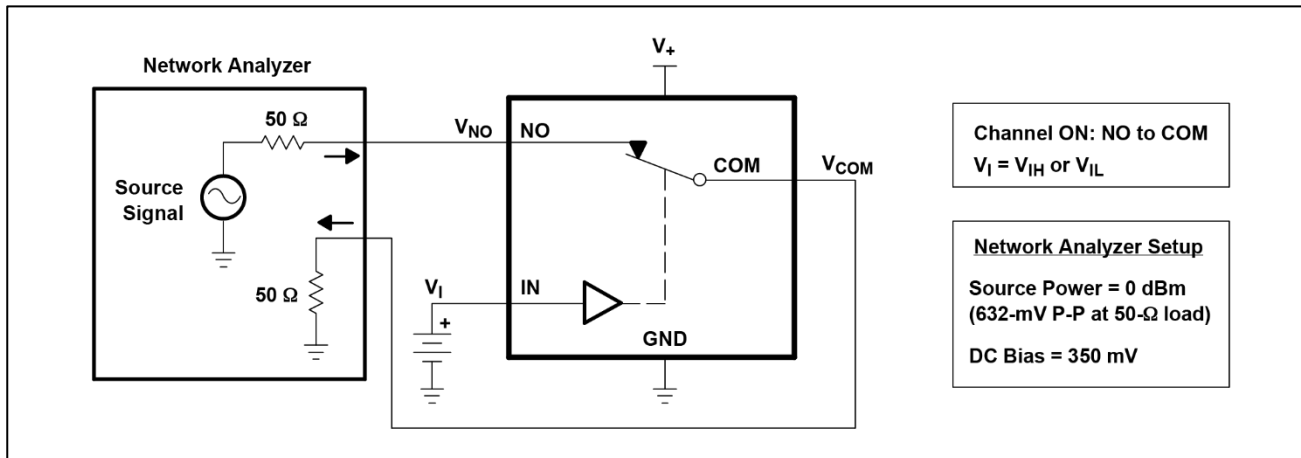

Figure 7. Bandwidth (BW)

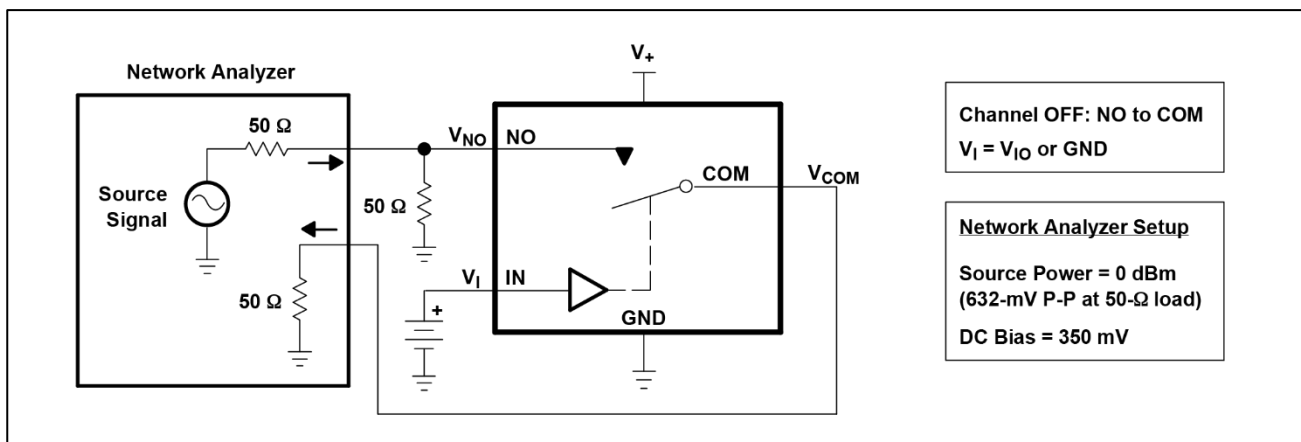

Figure 8. OFF Isolation (O_{iso})

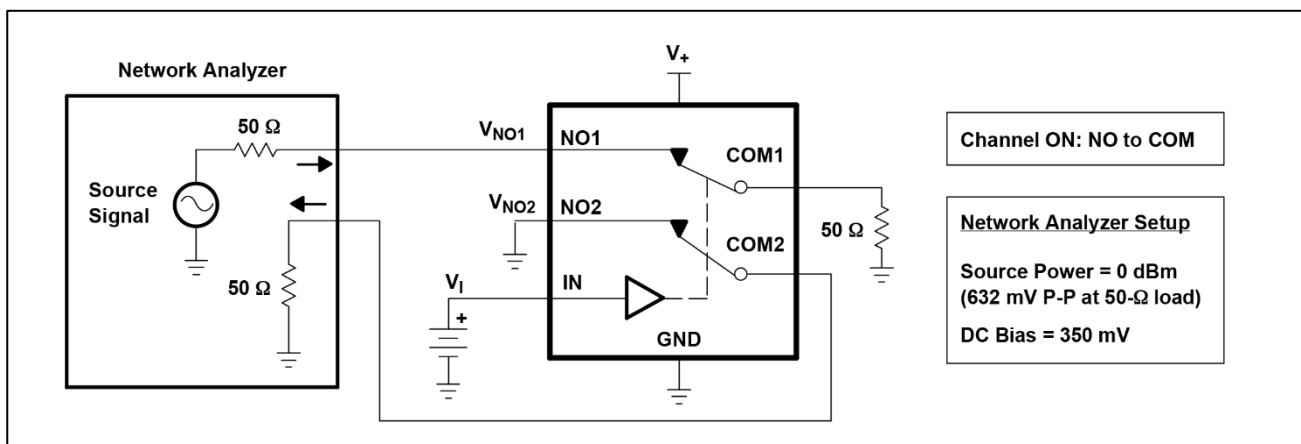

Figure 9. Crosstalk (X_{TALK})

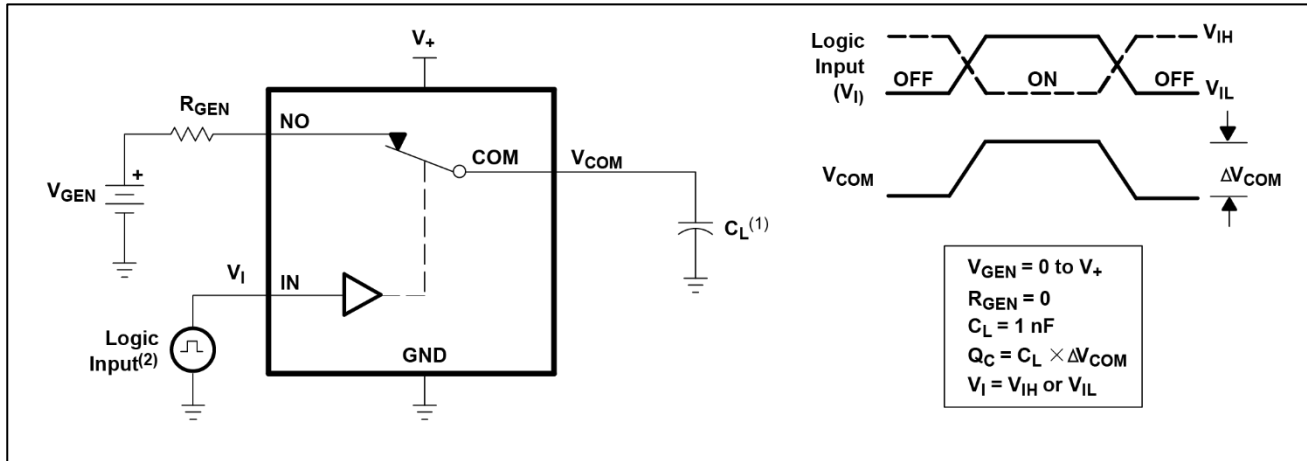

Figure 10. Charge Injection (Q_C)

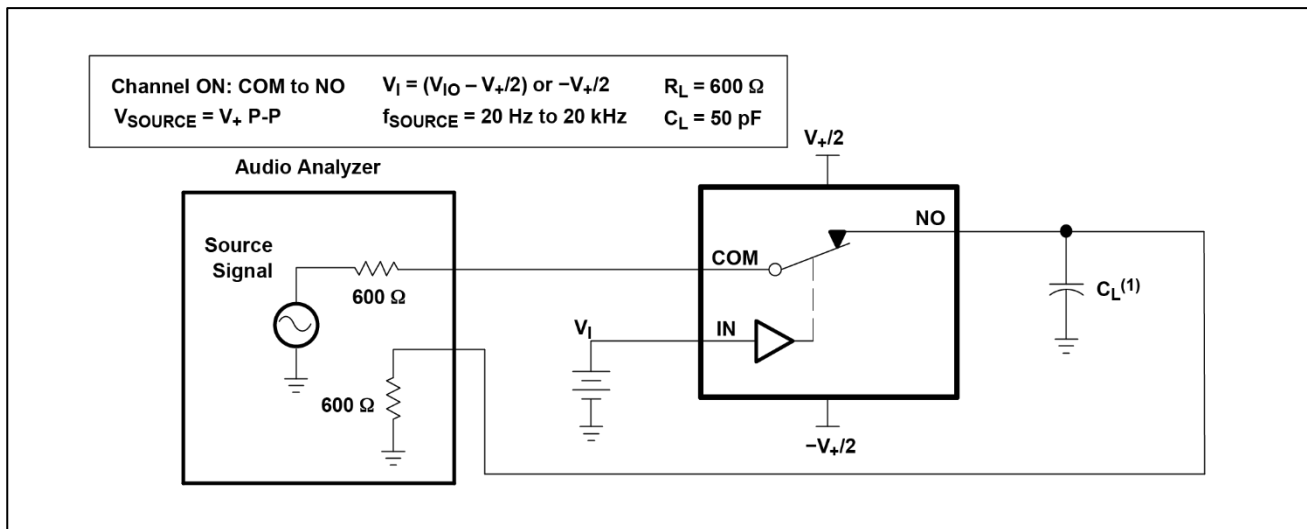

Figure11.Total Harmonic Distort

TYPICAL APPLICATION

Ensure that the device is powered up with a supply voltage on VCC before a voltage can be applied to the signal paths NC and NO. All unused digital inputs of the device must be held at VCC or GND to ensure proper device operation. Tie the digitally controlled inputs select pins IN1 and IN2 to VCC or GND to avoid unwanted switch states that could result if the logic control pins are left floating.

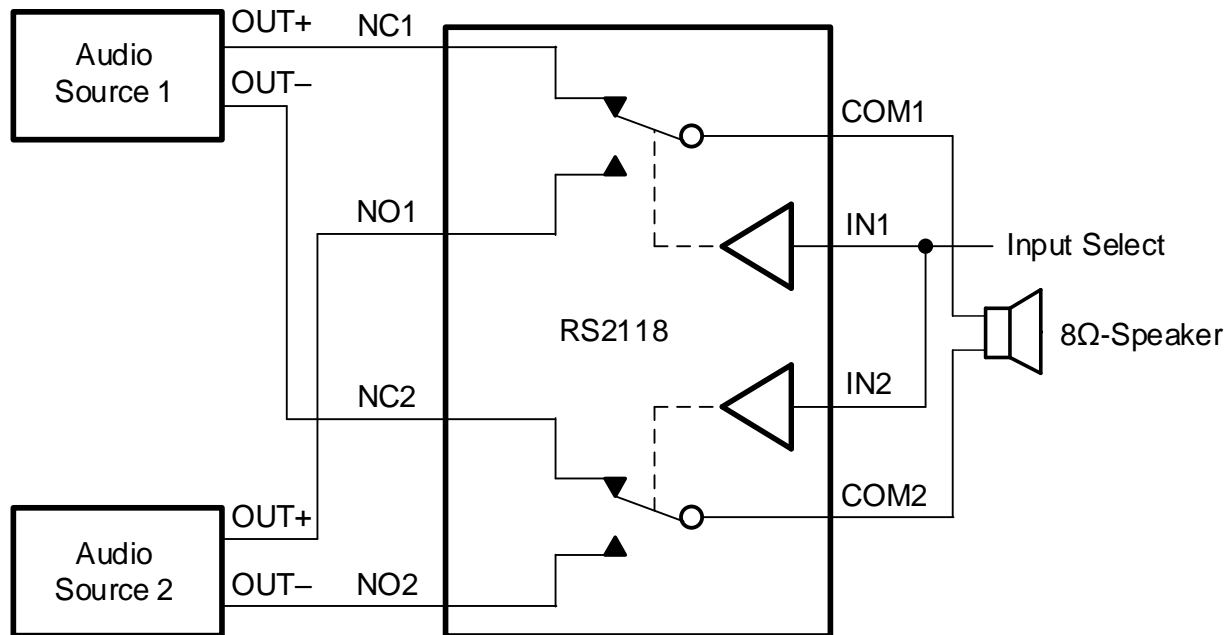
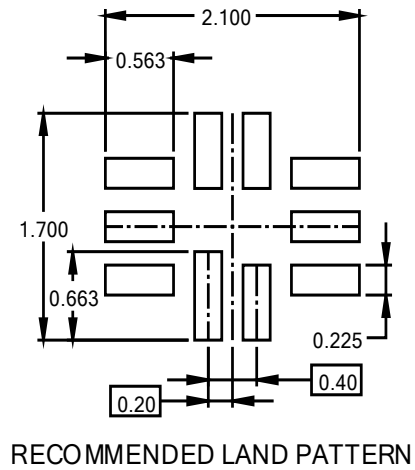
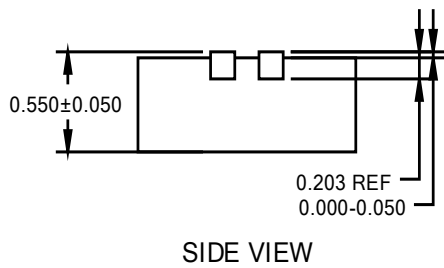
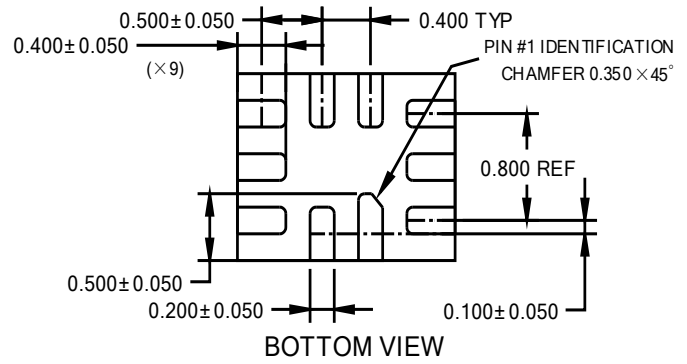
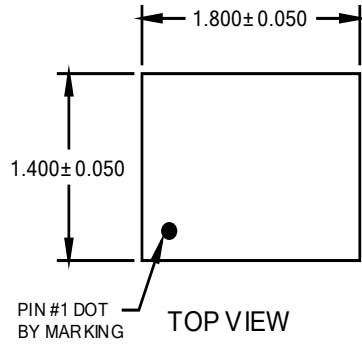

Figure 12. Typical Application Schematic

PACKAGE OUTLINE DIMENSIONS

QFN-1.4x1.8-10L



X-ON Electronics

Largest Supplier of Electrical and Electronic Components

Click to view similar products for [Analogue Switch ICs category](#):

Click to view products by [RUSIC manufacturer](#):

Other Similar products are found below :

[FSA3051TMX](#) [NLVAS4599DTT1G](#) [MAX4992EVB+T](#) [MAX4684ETB+T](#) [BCM6522IPBG](#) [BCM65300IFSBG](#) [MAX14764ETA+T](#)
[TMUX1113RSVR](#) [TMUX1112RSVR](#) [ADG1436TRUZ-EP](#) [BL4684C](#) [PE423422A](#) [PE42359SCAA](#) [PE42540F](#) [RS550YUCM12](#)
[ADGS1414DBCCZ](#) [ADG658YRUZ-REEL7](#) [RS2117YUTQK10](#) [RS2118YUTQK10](#) [RS2227XUTQK10](#) [SP2526A-1EN-L/TR](#) [FSA4157P6X](#)
[BA7603F-E2](#) [MAX4702EUE+](#) [MAX4617CUE+](#) [MAX4599EUT+T](#) [MAX4066ESD+](#) [MAX4052ACSE+](#) [MAX396CAI+](#) [MAX391CPE+](#)
[MAX4730EXT+T](#) [MAX314CPE+](#) [MAX4051AEEE+](#) [BU4066BCFV-E2](#) [MAX313CPE+](#) [BU4S66G2-TR](#) [TS3A4751PWR](#)
[NCN1154MUTAG](#) [DG444DY-E3](#) [NLAS4157DFT2G](#) [NLAS4599DFT2G](#) [NLAS7242MUTBG](#) [NLASB3157DFT2G](#) [NLAST4599DFT2G](#)
[NLAST4599DTT1G](#) [DG403DY-T1-E3](#) [MAX4714EXTT](#) [MAX392CPE](#) [BGSX22G2A10E6327XTSA1](#) [ADG1611BRUZ-REEL7](#)