

Wide-Bandwidth 4-Channel SPDT Video Analog Switch

1 FEATURES

- **Qualified for Automotive Applications**
- **AEC-Q100 Qualified with the Grade 1**
- **Wide Bandwidth: 220MHz**
- **Single Supply Operation +1.8V to +5.5V**
- **Low ON Resistance, 8Ω(TYP)**
Low Crosstalk: -60dB at 10MHz (TYP)
- **Rail-to-Rail Operation**
- **Fast Switching Time**
- **Operating Temperature Range:**
-40°C to +125°C
- **PACKAGES: SOIC-16(SOP16), TSSOP-16**

2 APPLICATIONS

- **Automotive Zonal & Body Domain Controller**
- **HEV/EV Battery Management System (BMS)**

3 DESCRIPTIONS

The RS2233-Q1 is a CMOS analog IC configured as a quad, bidirectional, single-pole/double-throw (SPDT) switches. This CMOS device can operate from 1.8 V to 5.5 V.

The select (IN) input control the data flow. The FET multiplexers/demultiplexers are disabled when the output-enable (\overline{OE}) input is high.

The device are digitally-controlled analog switches. It has low on-resistance (8Ω TYP) and low crosstalk (-60dB at 10MHz TYP).

The RS2233-Q1 is available in Green SOIC-16(SOP16), TSSOP-16 packages. It operates over an ambient temperature range of -40°C to +125°C.

Device Information ⁽¹⁾

PART NUMBER	PACKAGE	BODY SIZE (NOM)
RS2233-Q1	SOIC-16(SOP16)	9.90mm×3.90mm
	TSSOP-16	5.00mm×4.40mm

(1) For all available packages, see the orderable addendum at the end of the data sheet.

Table of Contents

1 FEATURES	1
2 APPLICATIONS	1
3 DESCRIPTIONS	1
4 Revision History	3
5 PACKAGE/ORDERING INFORMATION ⁽¹⁾	4
6 Pin Configuration and Function	5
7 PIN CONFIGURATIONS	6
8 SPECIFICATIONS	7
8.1 Absolute Maximum Ratings ⁽¹⁾	7
8.2 ESD Ratings	7
8.3 Recommended Operating Conditions	7
8.4 ELECTRICAL CHARACTERISTICS	8
9 TYPICAL CHARACTERISTICS	10
10 Parameter Measurement Information	11
11 PACKAGE OUTLINE DIMENSIONS	13
12 TAPE AND REEL INFORMATION	15

4 Revision History

Note: Page numbers for previous revisions may differ from page numbers in the current version.

Version	Change Date	Change Item
A.0	2022/09/21	Preliminary version completed
A.1	2023/06/09	Initial version completed
A.2	2023/08/10	1. Add ΔR_{ON} and $R_{FLAT(ON)}$ PARAMETER 2. Add Typical Ron as a Function of Input Voltage curve in 9 TYPICAL CHARACTERISTICS

5 PACKAGE/ORDERING INFORMATION ⁽¹⁾

PRODUCT	ORDERING NUMBER	TEMPERATURE RANGE	PACKAGE LEAD	Lead finish/Ball material ⁽²⁾	MSL Peak Temp ⁽³⁾	PACKAGE MARKING ⁽⁴⁾	PACKAGE OPTION
RS2233-Q1	RS2233XS16-Q1	-40°C~+125°C	SOIC-16 (SOP16)	NIPDAUAG	MSL1-260°-Unlimited	RS2233	Tape and Reel,4000
	RS2233XTSS16-Q1	-40°C~+125°C	TSSOP-16	NIPDAUAG	MSL1-260°-Unlimited	RS2233	Tape and Reel,4000

NOTE:

- (1) This information is the most current data available for the designated devices. This data is subject to change without notice and revision of this document. For browser-based versions of this data sheet, refer to the right-hand navigation.
- (2) Lead finish/Ball material. Orderable Devices may have multiple material finish options. Finish options are separated by a vertical ruled line. Lead finish/Ball material values may wrap to two lines if the finish value exceeds the maximum column width.
- (3) MSL Peak Temp. The Moisture Sensitivity Level rating according to the JEDEC industry standard classifications, and peak solder temperature.
- (4) There may be additional marking, which relates to the lot trace code information (data code and vendor code), the logo or the environmental category on the device.

6 Pin Configuration and Function

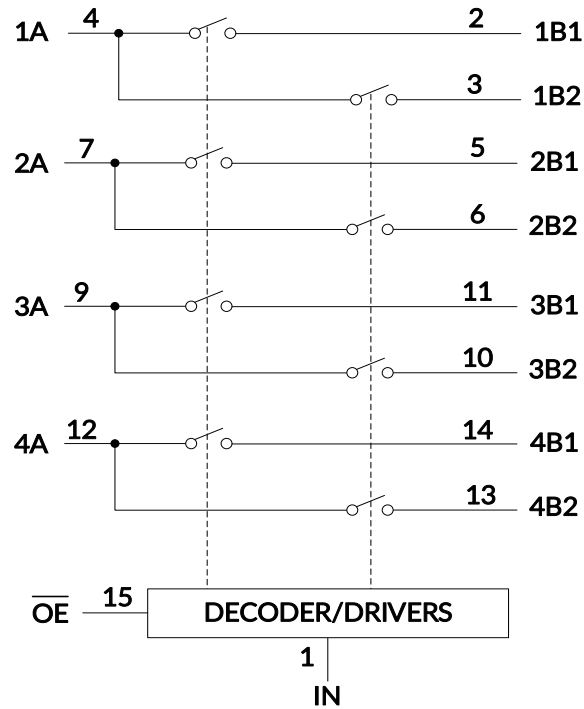

FUNCTION TABLE

INPUTS		FUNCTION
\overline{OE}	IN	
L	L	A port =B1 port
L	H	A port =B2 port
H	X	Disconnect

X=Don't care

NOTE: Input and output pins are identical and inter-changeable. Either may be considered an input or output; signals pass equally well in either direction.

7 PIN CONFIGURATIONS

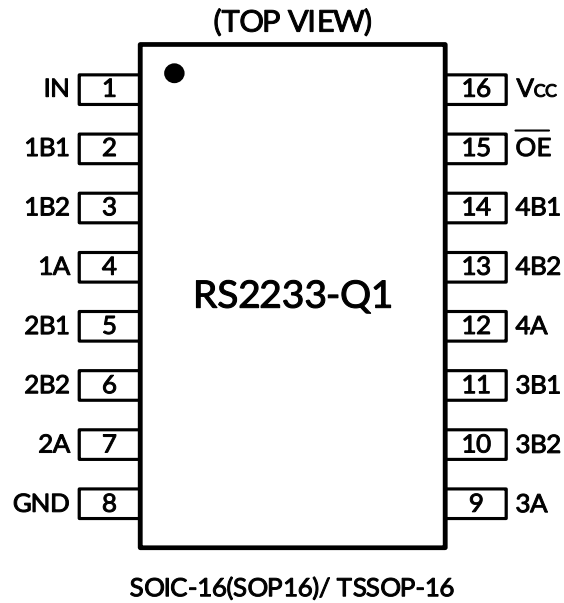

PIN DESCRIPTION

NAME	PIN	FUNCTION
	SOIC-16(SOP16) / TSSOP-16	
IN	1	Select Input.
1B1	2	Analog Video I/O.
1B2	3	Analog Video I/O.
1A	4	Analog Video I/O.
2B1	5	Analog Video I/O.
2B2	6	Analog Video I/O.
2A	7	Analog Video I/O.
GND	8	Ground.
3A	9	Analog Video I/O.
3B2	10	Analog Video I/O.
3B1	11	Analog Video I/O.
4A	12	Analog Video I/O.
4B2	13	Analog Video I/O.
4B1	14	Analog Video I/O.
\overline{OE}	15	Switch-Enable Input.
V _{cc}	16	Power Supply.

8 SPECIFICATIONS

8.1 Absolute Maximum Ratings ⁽¹⁾

Over operating free-air temperature range (unless otherwise noted) ⁽¹⁾

SYMBOL	PARAMETER		MIN	MAX	UNIT
V _{CC}	Supply Voltage		-0.3	6	V
V _{IN}	Input Voltage (All inputs)		-0.3	V _{CC} +0.3	
I _{IK}	Input clamp current	V _{IO} < 0		-50	mA
θ _{JA}	Package thermal impedance ⁽²⁾			150	°C/W
				45	
T _J	Junction temperature ⁽³⁾		-40	150	°C
T _{stg}	Storage temperature		-65	+150	°C

(1) Stresses above these ratings may cause permanent damage. Exposure to absolute maximum conditions for extended periods may degrade device reliability. These are stress ratings only, and functional operation of the device at these or any other conditions beyond those specified is not implied.

(2) The package thermal impedance is calculated in accordance with JESD-51.

(3) The maximum power dissipation is a function of T_{J(MAX)}, R_{θJA}, and T_A. The maximum allowable power dissipation at any ambient temperature is P_D = (T_{J(MAX)} - T_A) / R_{θJA}. All numbers apply for packages soldered directly onto a PCB.

8.2 ESD Ratings

The following ESD information is provided for handling of ESD-sensitive devices in an ESD protected area only.

			VALUE	UNIT
V _(ESD)	Electrostatic discharge	Human-Body Model (HBM), per AEC Q100-002 ⁽¹⁾	±2000	V
		Charged-Device Model (CDM), per AEC Q100-011	±1000	
		Latch-Up (LU), per AEC Q100-004	±100	mA

(1) AEC Q100-002 indicates that HBM stressing shall be in accordance with the ANSI/ESDA/JEDEC JS-001 specification.



ESD SENSITIVITY CAUTION

ESD damage can range from subtle performance degradation to complete device failure. Precision integrated circuits may be more susceptible to damage because very small parametric changes could cause the device not to meet its published specifications.

8.3 Recommended Operating Conditions

Over operating free-air temperature range (unless otherwise noted)

SYMBOL	PARAMETER	MIN	MAX	UNIT
V _{CC}	Supply Voltage	1.8	5.5	V
T _A	Operating temperature	-40	+125	°C

8.4 ELECTRICAL CHARACTERISTICS

V_{CC} = +1.8V to +5.5 V, FULL= -40°C to +125°C, Typical values are at T_A = +25°C. (unless otherwise noted)

PARAMETER	SYMBOL	CONDITIONS	V _{CC}	T _A	MIN ⁽¹⁾	TYP ⁽²⁾	MAX ⁽¹⁾	UNIT
DC CHARACTERISTICS								
On-Resistance	R _{ON}	I _A = 13mA	5V	+25°C		8	11	Ω
				FULL			14	
On-Resistance Match Between Channels	ΔR _{ON} ⁽³⁾	I _A = 13mA	5V	+25°C		0.05	0.2	Ω
				FULL			0.25	Ω
On-Resistance Flatness	R _{FLAT(ON)} ⁽⁴⁾		5V	+25°C		4.5	6	Ω
				FULL			8	Ω
High-level control input Voltage	V _{IH}		1.8V	FULL	1.1			V
			2.5V to 5.5V	FULL	2			
Low-level control input Voltage	V _{IL}		1.8V	FULL			0.4	V
			2.5V to 5.5V	FULL			0.5	
Input High Current	I _{IH}	V _{IN} and V _{OE} = V _{CC}	5.5V	+25°C			±1	μA
				FULL			±2	
Input Low Current	I _{IL}	V _{IN} and V _{OE} = 0V	5.5V	+25°C			±1	μA
				FULL			±2	
Analog Output Leakage Current	I _O	V _{B1} or V _{B2} = 3.3V/0.3V V _A = 0.3V/3.3V	5.5V	+25°C			±1	μA
				FULL			±2	
Clamp Diode Voltage	V _{IK}	I _I = -18mA	5.5V	+25°C		-0.9		V
DYNAMIC CHARACTERISTICS								
Turn-On Time	t _{ON}	R _L = 75Ω, C _L = 20pF, Test Circuit 1	5.5V	+25°C		13	20	ns
				FULL			23	
			3.3V	+25°C		19	29	ns
				FULL			32	
Turn-Off Time	t _{OFF}	R _L = 75Ω, C _L = 20pF, Test Circuit 1	5.5V	+25°C		30	55	ns
				FULL			60	
			3.3V	+25°C		40	60	ns
				FULL			68	
-3dB Bandwidth	BW	R _L = 150Ω, Test Circuit 3	5.5V	+25°C		220		MHz
Channel-to-Channel Crosstalk	X _{TALK}	R _{IN} = 10Ω, R _L = 150Ω, f = 10MHz, Test Circuit 4	5.5V	+25°C		-60		dB
Off Isolation	O _{IRR}	R _L = 150Ω, f = 10MHz, Test Circuit 5	5.5V	+25°C		-52		dB
Input/Enable Capacitance	C _{IN}	f = 1MHz, Test Circuit 5	5.5V	+25°C		5		pF
Switch OFF Capacitance	C _{OFF}	f = 1MHz, Test Circuit 5	5.5V	+25°C		9		pF
Switch ON Capacitance	C _{ON}	f = 1MHz, Test Circuit 5	5.5V	+25°C		18		pF
Differential Gain	D _G	R _L = 150Ω, f = 3.58MHz, Test Circuit 2	5.5V	+25°C		0.5		%
Differential Phase	D _P	R _L = 150Ω, f = 3.58MHz, Test Circuit 2	5.5V	+25°C		0.05		°

POWER REQUIREMENTS								
Power Supply Range	V _{CC}			FULL	1.8		5.5	V
Power Supply Current	I _{CC}	V _{IN} and V _{OE} = 5V/0V	5.5V	+25°C		0.1	1	μA
				FULL			2	
Supply Current per Input @ TTL HIGH	ΔI _{CC}	V _{IN} or V _{OE} = 3.4V	5.5V	+25°C			100	μA
				FULL			200	

- (1) Limits are 100% production tested at 25°C. Limits over the operating temperature range are ensured through correlations using statistical quality control (SQC) method.
- (2) Typical values represent the most likely parametric norm as determined at the time of characterization. Actual typical values may vary over time and will also depend on the application and configuration.
- (3) This parameter is ensured by design and/or characterization and is not tested in production.
- (4) Flatness is defined as the difference between the maximum and minimum values of ON-state resistance over the specified range of conditions.

9 TYPICAL CHARACTERISTICS

NOTE: The graphs and tables provided following this note are a statistical summary based on a limited number of samples and are provided for informational purposes only.

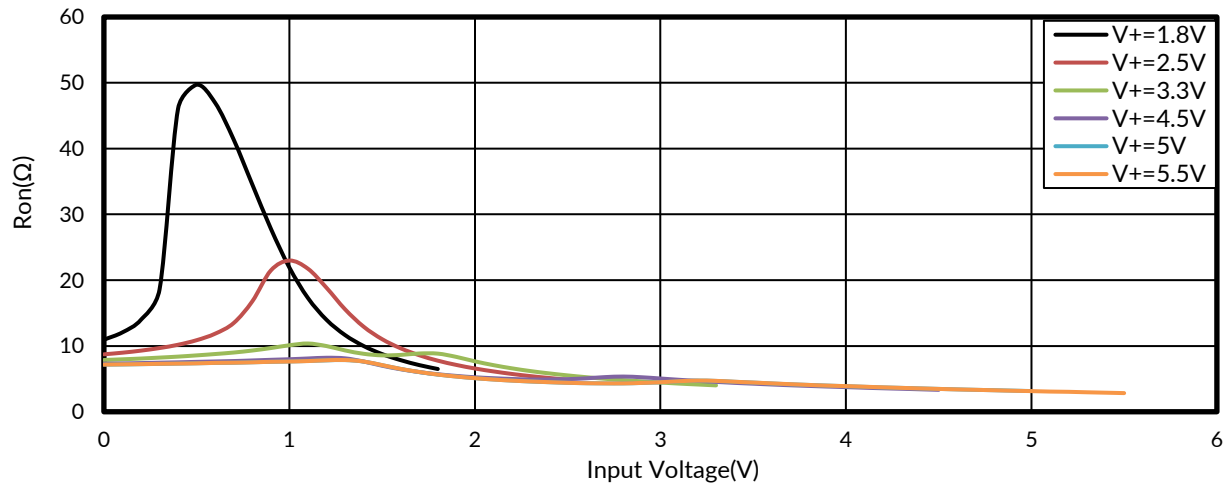
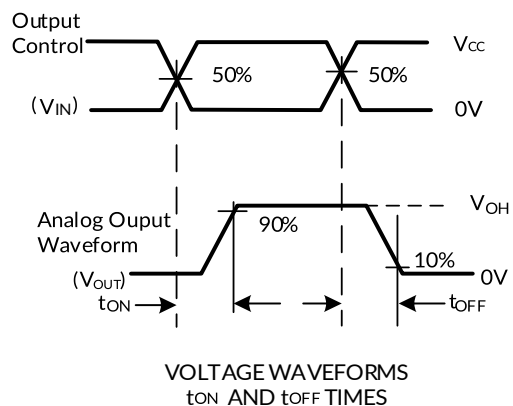
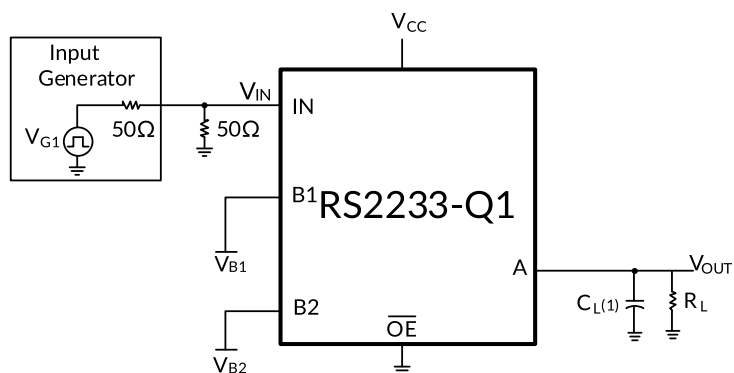

Figure 1. Typical Ron as a Function of Input Voltage

10 Parameter Measurement Information



Test	V _{CC}	R _L	C _L	V _{B1}	V _{B2}
t _{ON}	5V±0.5V	75Ω	20pF	GND	3V
	5V±0.5V	75Ω	20pF	3V	GND
t _{OFF}	5V±0.5V	75Ω	20pF	GND	3V
	5V±0.5V	75Ω	20pF	3V	GND

NOTES:

- 1.CL includes probe and jig capacitance.
- 2.All input pulses are supplied by generators having the following characteristics: PRR≤10MHz,Z_o=50Ω. t_r≤2.5ns,t_f≤2.5ns.
3. The outputs are measured one at a time, with one transition per measurement.

Test Circuit 1. Test Circuit for Voltage Waveform and Switch Time

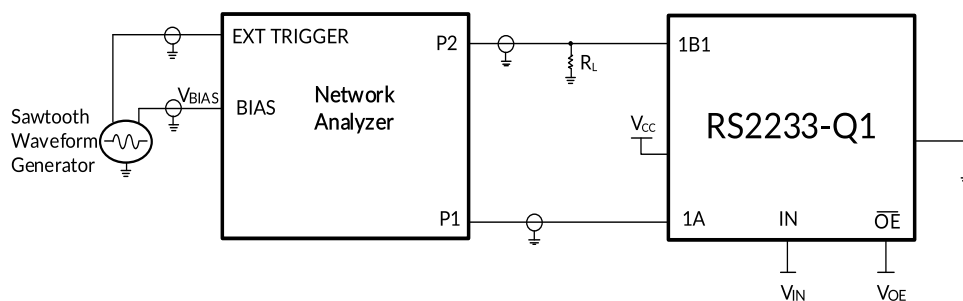

NOTES: Differential gain and phase are measured at the output of the ON channel. For example, when V_{IN} = 0, V_{OE} = 0, and 1A is the input, the output is measured at 1B1.

Test Circuit 2. Test Circuit for Differential Gain/Phase Measurement

Parameter Measurement Information

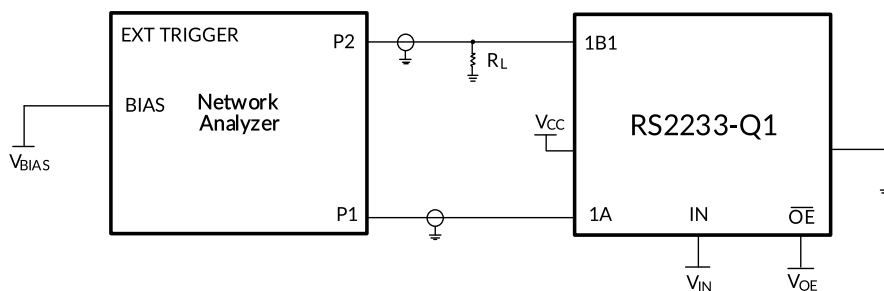

NOTES: Frequency response is measured at the output of the ON channel. For example, when $V_{IN} = 0$, $V_{EN} = 0$, and 1A is the input, the output is measured at 1B1. All unused analog I/O ports are left open.

Test Circuit 3. Test Circuit for Frequency Response (BW)

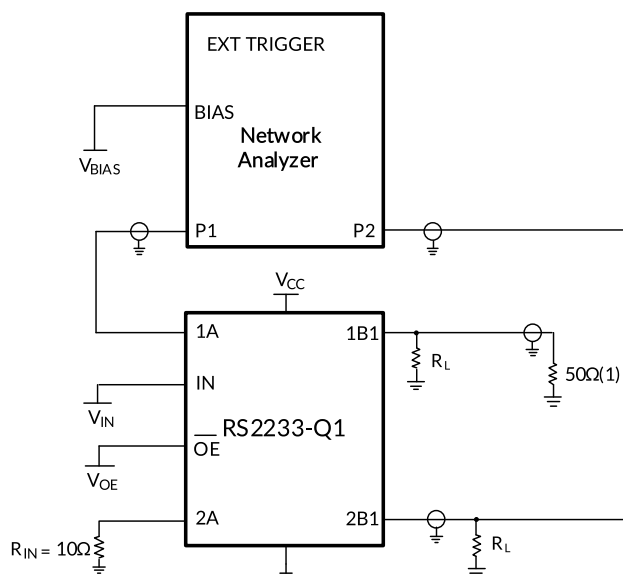

NOTE: 1. A 50Ω termination resistor is needed for the network analyzer.

Test Circuit 4. Test Circuit for Crosstalk (X_{TALK})

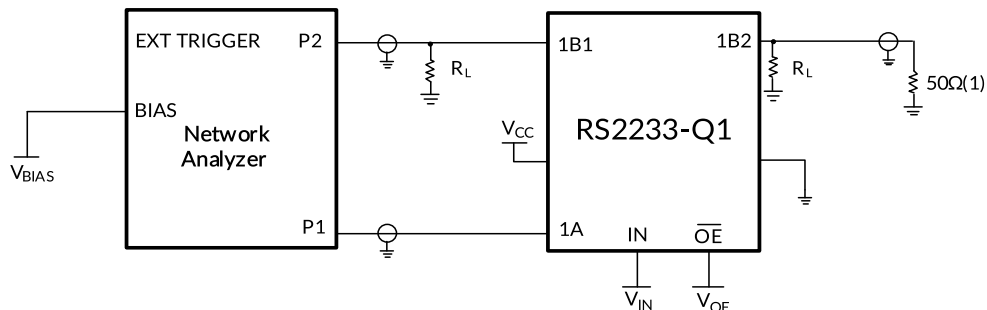

NOTE: 1. A 50Ω termination resistor is needed for the network analyzer.

Test Circuit 5. Test Circuit for Off Isolation (O_{IRR})

11 PACKAGE OUTLINE DIMENSIONS

SOIC-16(SOP16)⁽²⁾

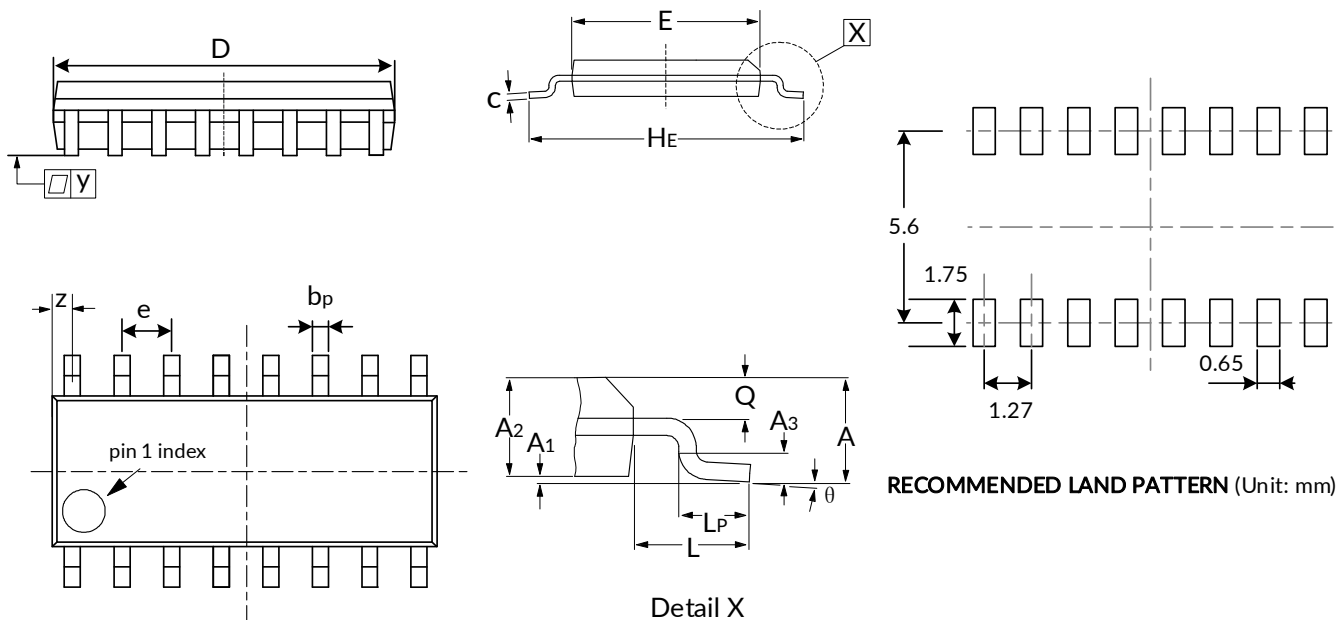

Symbol	Dimensions In Millimeters		Dimensions In Inches	
	Min	Max	Min	Max
A ⁽¹⁾		1.750		0.069
A ₁	0.100	0.250	0.004	0.010
A ₂	1.250	1.450	0.049	0.057
A ₃	0.25		0.010	
b _p	0.360	0.490	0.014	0.019
c	0.190	0.250	0.007	0.010
D ⁽¹⁾	9.800	10.00	0.380	0.390
E ⁽¹⁾	3.800	4.000	0.150	0.160
H _E	5.800	6.200	0.228	0.244
e	1.270		0.050	
L	1.05		0.041	
L _P	0.400	1.000	0.016	0.039
Q	0.600	0.700	0.020	0.028
Z	0.300	0.700	0.012	0.028
y	0.1		0.004	
θ	0°	8°	0°	8°

NOTE:

1. Plastic or metal protrusions of 0.15mm maximum per side are not included.
2. This drawing is subject to change without notice.

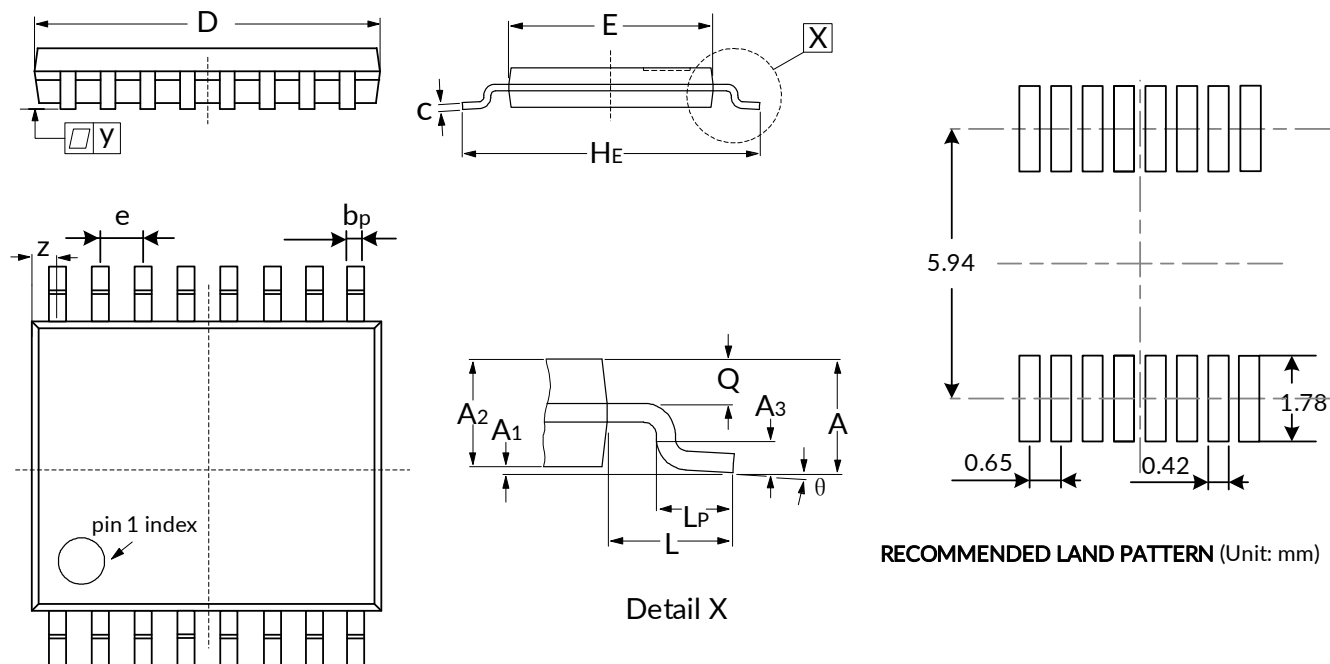
TSSOP-16 (2)

RECOMMENDED LAND PATTERN (Unit: mm)

Symbol	Dimensions In Millimeters		Dimensions In Inches	
	Min	Max	Min	Max
A ⁽¹⁾		1.100		0.043
A ₁	0.050	0.150	0.002	0.006
A ₂	0.800	0.950	0.031	0.037
A ₃	0.25		0.010	
b _p	0.190	0.300	0.007	0.012
c	0.100	0.200	0.004	0.008
D ⁽¹⁾	4.900	5.100	0.193	0.201
E ⁽¹⁾	4.300	4.500	0.169	0.177
H _E	6.200	6.600	0.244	0.260
e	0.650		0.026	
L	1		0.039	
L _P	0.500	0.750	0.020	0.030
Q	0.300	0.400	0.012	0.016
Z	0.060	0.400	0.002	0.016
y	0.1		0.004	
θ	0°	8°	0°	8°

NOTE:

1. Plastic or metal protrusions of 0.15mm maximum per side are not included.
2. This drawing is subject to change without notice.

12 TAPE AND REEL INFORMATION

REEL DIMENSIONS

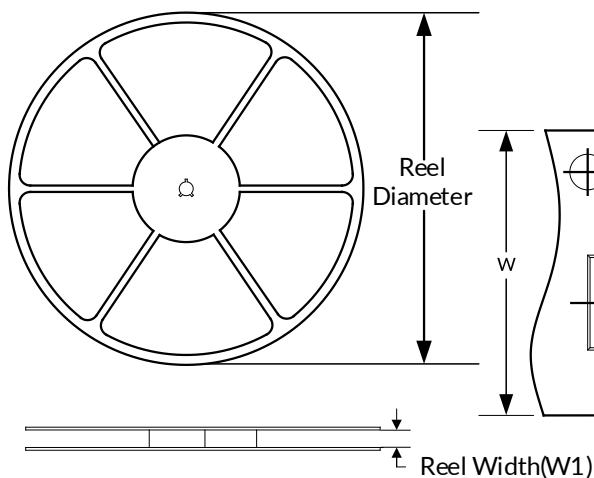

TAPE DIMENSION

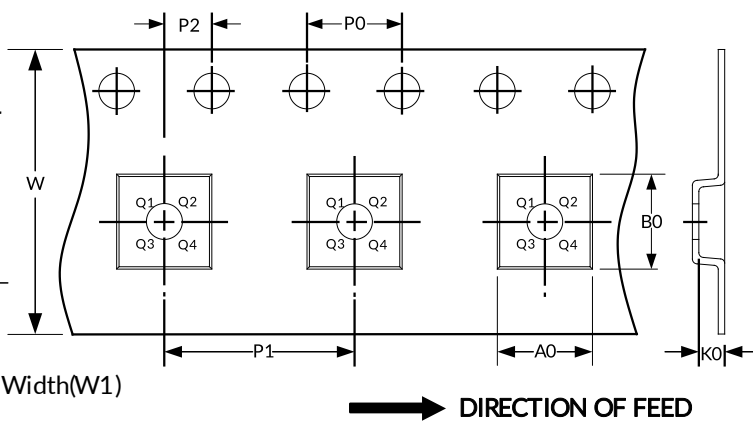

NOTE: The picture is only for reference. Please make the object as the standard.

KEY PARAMETER LIST OF TAPE AND REEL

Package Type	Reel Diameter	Reel Width(mm)	A0 (mm)	B0 (mm)	K0 (mm)	P0 (mm)	P1 (mm)	P2 (mm)	W (mm)	Pin1 Quadrant
TSSOP-16	13"	12.4	6.90	5.60	1.20	4.0	8.0	2.0	12.0	Q1
SOIC-16(SOP16)	13"	16.4	6.50	10.30	2.10	4.0	8.0	2.0	16.0	Q1

NOTE:

1. All dimensions are nominal.
2. Plastic or metal protrusions of 0.15mm maximum per side are not included.

IMPORTANT NOTICE AND DISCLAIMER

Jiangsu Runic Technology Co., Ltd. will accurately and reliably provide technical and reliability data (including data sheets), design resources (including reference designs), application or other design advice, WEB tools, safety information and other resources, without warranty of any defect, and will not make any express or implied warranty, including but not limited to the warranty of merchantability Implied warranty that it is suitable for a specific purpose or does not infringe the intellectual property rights of any third party.

These resources are intended for skilled developers designing with Runic products You will be solely responsible for: (1) Selecting the appropriate products for your application; (2) Designing, validating and testing your application; (3) Ensuring your application meets applicable standards and any other safety, security or other requirements; (4) Runic and the Runic logo are registered trademarks of Runic Incorporated. All trademarks are the property of their respective owners; (5) For change details, review the revision history included in any revised document. The resources are subject to change without notice. Our company will not be liable for the use of this product and the infringement of patents or third-party intellectual property rights due to its use.

X-ON Electronics

Largest Supplier of Electrical and Electronic Components

Click to view similar products for [Analogue Switch ICs category](#):

Click to view products by [RUNIC manufacturer](#):

Other Similar products are found below :

[FSA3051TMX](#) [NLAS5223BLMNR2G](#) [NLVAS4599DTT1G](#) [NLX2G66DMUTCG](#) [425541DB](#) [DG403DY](#) [099044FB](#) [MAX4762ETB+](#)
[NLAS3799BMNR2G](#) [NLAS5123MNR2G](#) [ISL84684IR](#) [PI5A4157CEX](#) [PI5A4599BCEX](#) [NLAS4717EPFCT1G](#) [PI5A3167CCEX](#)
[SLAS3158MNR2G](#) [PI5A392AQE](#) [NX3L1T5157GMZ](#) [ADG714BCPZ-REEL7](#) [DG333ALDW-T1-E3](#) [ISL43113IB](#) [ISL43140IB](#)
[ISL43140IBZ-T](#) [ISL43143IR](#) [ISL43L120IR](#) [ISL43L121IR](#) [ISL43L122IR](#) [ISL43L220IR](#) [ISL43L410IR](#) [ISL43L420IR](#) [ISL43L710IR](#)
[ISL43L711IR](#) [ISL43L712IR](#) [ISL84053IA](#) [ISL84514IB](#) [ISL84516IB](#) [ISL84684IUZ-T](#) [LNLASB3157DFT2G](#) [NLAS324US](#) [TPW4053-SR](#)
[HT4069ARZ](#) [CD4052BM](#) [RS2252XTQC16](#) [RS2166XC5](#) [4066G-S14-R](#) [WAS4642Q-24/TR](#) [WS4612EAA-5/TR](#) [TS5A3157DBVR\(UMW\)](#)
[SN74LVC1G66DBVR](#) [SN74LVC1G66DCKR\(UMW\)](#)